

SWIVEL HOIST RING



OPERATION NOTE

- 1、 Hoist rings are not used for long-term bearing capacity; it can not swivel for long time.
- 2、 During the lifting process, it is forbidden to swing and sway the sling, and the lifting must be moved at a constant speed and slowly.
- 3、 When the lifting process slips and slides, please stop using it immediately.
- 4、 When the hoist ring uses in the chemical environment, please consult the manufacturer.
- 5、 If it found that hoist ring of corrosion, cracks, abrasion, bending, deformation, or damage, it is prohibited to use Continually.

Installation instruction

1. The threaded hole of the lifting object must be perpendicular to the surface of the object, and the thread size matches the swivel ring.
2. The bottom of the swivel ring must be tightly attached to the lifting object, to prevent gaps from causing large bending moments and to prevent from reducing the life of the hoist ring.
3. Prohibited to put gasket or other fittings between the hoist ring and the lifting object, or remodel the hoist ring.

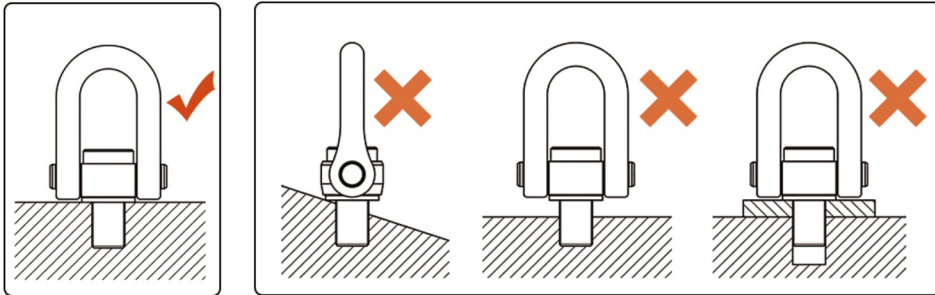

4. The hoist ring must be mounted on a hard metal surface such as steel or iron. It is forbidden to be installed on soft materials such as wood boards and cement.
5. Chose the right lifting tool to match with hoist ring, and ensure that the direction of force is appropriate.
6. The hoist ring must be mounted at the center of gravity or symmetrically mounted around the center of gravity.
7. After the hoist ring is installed, when the hoist ring is forced, the hoist ring cannot interfere or obstruct the suspended object.

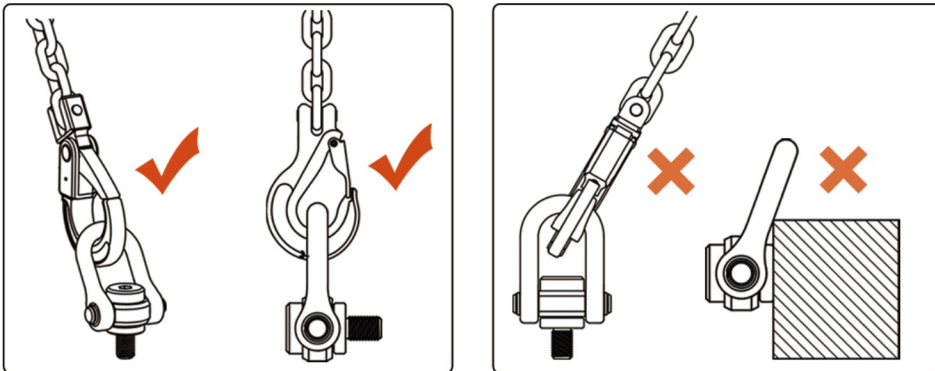

Inspection and maintenance



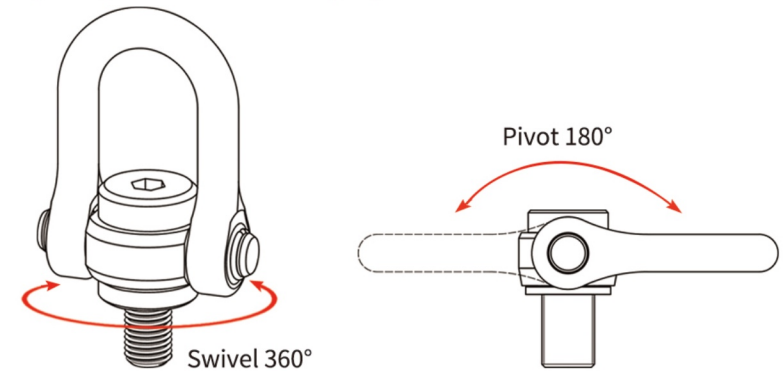



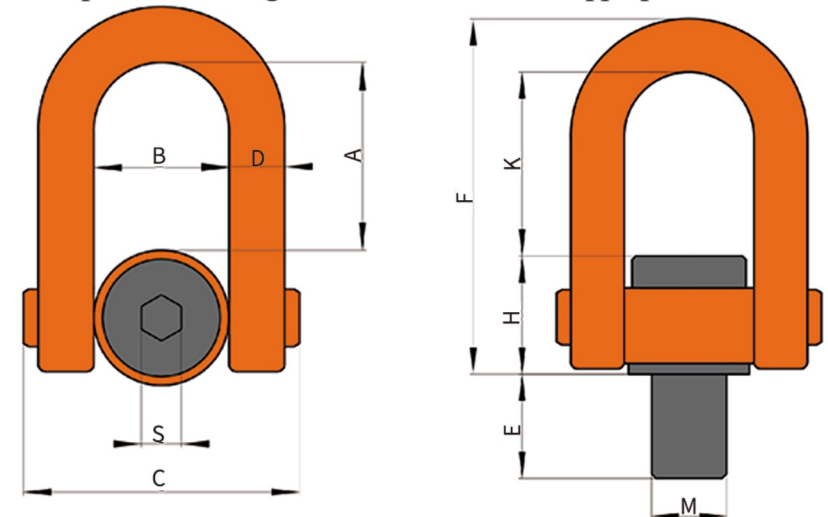

1. Please check the appearance before using the hoist ring, if it is found that there are signs of corrosion, cracks, abrasion, bending, deformation, or damage, it is prohibited to use continually.
2. Before using the hoist ring, please check if the swivel and pivot are smooth, the hoist ring should be swivel 360° with pivot 180°.
3. Before using the hoist ring, please check if the thread and threaded hole are properly fitted, and whether the bolts are locked.
4. Regularly inspect the hoist ring crack.
5. Please keep the product clean and proper use environment.



- ⚠** According to the weight of the lifting object and the lifting plan, strictly follow the product working load form and select the appropriate model.



NO.	WLL/t	SPEC	parameters mm								Locking torque		U.W kg
			E	A±3	B±3	C	D	F	K±3	H	S	Nm	
M8	0.5	M8×1.25	12	50.5	37	76	14	101.5	49.5	38	8	10-40	0.8
M10	0.7	M10×1.5	16	50.5	37	76	14	101.5	49.5	38	8	10-40	0.8
M12	1	M12×1.75	18	50.5	37	76	14	101.5	49.5	38	8	15-40	0.8
M14	1.5	M14×2.0	21	50.5	37	76	14	101.5	49.5	38	8	30-100	0.8
M16	2	M16×2.0	24	50.5	37	76	14	101.5	49.5	38	8	45-130	0.8
M18	2.5	M18×2.5	40	74.5	54	105	20	145	77	48	12	100-170	1.9
M20	3	M20×2.5	40	74.5	54	105	20	145	77	48	12	100-170	2
M22	3	M22×2.5	40	74.5	54	105	20	145	77	48	12	100-170	2.1
M24	4.5	M24×3.0	40	74.5	54	105	20	145	77	48	12	190-280	2.5
M27	5	M27×3.0	40	98.5	73	149	30	201.5	103.5	68	17	250-500	5.5
M30	7.3	M30×3.5	45	98.5	73	149	30	201.5	103.5	68	17	270-600	5.5
M33	8	M33×3.5	50	98.5	73	149	30	201.5	103.5	68	17	270-600	5.5
M36	10	M36×4.0	54	98.5	73	149	30	201.5	103.5	68	17	270-600	5.5
M39	10	M39×4.0	58	98.5	73	149	30	201.5	103.5	68	17	350-800	6
M42	12.5	M42×4.5	63	98.5	73	149	30	201.5	103.5	68	17	350-800	6
M45	15	M45×4.5	63	98.5	73	149	30	201.5	103.5	68	17	350-800	6
M48-S	16	M48×5.0	63	98.5	73	149	30	201.5	101.5	70	17	350-800	6.5
M48-B	20	M48×5.0	68	120	93	182	36	249	125	84	19	350-800	11.5
M52	20	M52×5.0	68	120	93	182	36	249	125	84	19	350-900	12
M56	25	M56×5.5	78	120	93	182	36	249	125	84	19	350-900	12
M60	25	M60×5.5	90	120	93	182	36	253	125	88	19	350-600	13
M64-S	32	M64×6.0	90	120	93	182	36	253	125	88	19	500-1000	13
M64-B	33	M64×6.0	100	185	144	280	58	395	195	136	36	500-1000	42
M72	35	M72×6.0	110	185	144	280	58	395	195	136	36	500-1200	43
M80	40	M80×6.0	120	185	144	280	58	395	195	136	36	500-1200	44.5
M90	45	M90×6.0	135	185	144	280	58	395	195	136	36	500-1500	46.5
M100	50	M100×6.0	150	185	144	280	58	395	195	136	36	500-1700	49

Lifting solution										
Number of leg	1	2	1	2	0-45°	45-60°	Asymmetric	0-45°	45-60°	Asymmetric
Load direction	0°	0°	90°	90°						
Product model	Lifting load / t									
M8	0.5	1	0.5	1	0.7	0.5	0.5	1.1	0.8	0.5
M10	0.7	1.4	0.7	1.4	1	0.7	0.7	1.5	1.1	0.7
M12	1	2	1	2	1.4	1	1	2.1	1.5	1
M14	1.5	3	1.5	3	2.1	1.5	1.5	3.15	2.3	1.5
M16	2	4	2	4	2.8	2	2	4.2	3	2
M18	2.5	5	2.5	5	3.5	2.5	2.5	5.25	3.75	2.5
M20	3	6	3	6	4.2	3	3	6.3	4.5	3
M22	3	6	3	6	4.2	3	3	6.3	4.5	3
M24	4.5	9	4.5	9	6.3	4.5	4.5	9.45	6.8	4.5
M27	5	10	5	10	7	5	5	10.5	7.5	5
M30	7.3	14.6	7.3	14.6	10.2	7.3	7.3	15.3	11	7.3
M33	8	16	8	16	11.2	8	8	16.8	12	8
M36	10	20	10	20	14	10	10	21	15	10
M39	10	20	10	20	14	10	10	21	15	10
M42	12.5	25	12.5	25	17.5	12.5	12.5	26.3	18.8	12.5
M45	15	30	15	30	21	15	15	31.5	22.5	15
M48-S	16	32	16	32	22.4	16	16	33.5	24	16
M48-B	20	40	20	40	28	20	20	42	30	20
M52	20	40	20	40	28	20	20	42	30	20
M56	25	50	25	50	35	25	25	53	37.5	25
M60	25	50	25	50	35	25	25	52.5	37.5	25
M64-S	32	64	32	64	45	32	32	67	48	32
M64-B	33	66	33	66	46.2	33	33	69.3	49.5	33
M72	35	70	35	70	49	35	35	73.5	52.5	35
M80	40	80	40	80	56	40	40	84	60	40
M90	45	90	45	90	63	45	45	94.5	67.5	45
M100	50	100	50	100	70	50	50	105	75	50