

P52E Pneumatikspanner mit horizontalem Zylinderanbau

P52E

Pneumatic toggle clamps

With horizontal cylinder attachment

Fitted with pneumatic cylinder, double-acting anodised, installed and ready to connect. Magnetic piston for end-position monitoring.

With flow-restriction drillings for reduced speed. Clamps are galvanized and passivated. Stainless steel rivets running in case-hardened bushes. Bearings are pre-lubricated.

Complete with tempered, galvanized clamping screw MS10/20

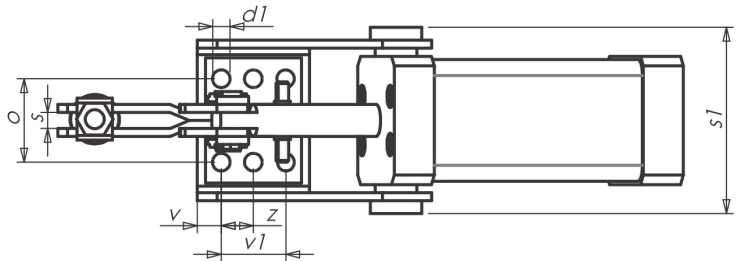
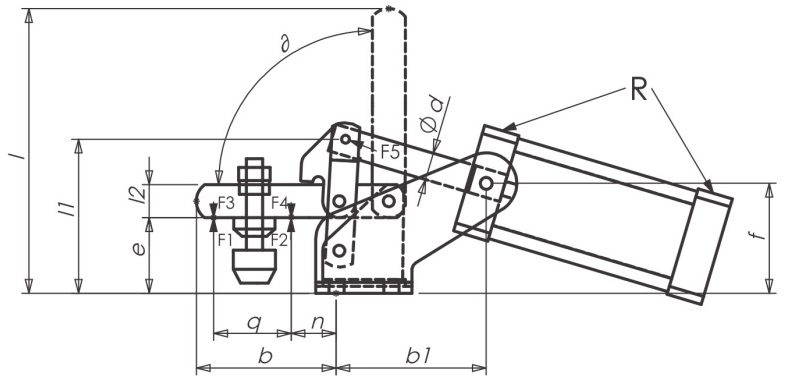

Order No	F1*** (kN)	F2 (kN)	F3* (kN)	F4* (kN)	F5 (kN)	hs**				
P52E/1	0.8	1.1	0.20	0.3	0.10	0.08	52	175	M5 x 30	610
P52E/2	1.0	1.2	0.70	1.0	0.30	0.26	64	200	M6 x 35	870
P52E/3	1.4	2.5	0.65	1.1	0.50	0.35	85	250	M8 x 45	1160
P52E/4	2.0	3.0	1.50	2.2	0.75	0.80	100	290	M8 x 65	1900

*F3 bzw. F4 = Max. erreichbare Spannkraften bei 6 bar
**hs = Luftverbrauch je Doppelhub in dm3 bei 6 bar



Order No	b	b1	d	d1	e	f	l	l1	l2	n	o	s	s1	v	v1	z	q	∅	Strok	Piston-∅	R
P52E/1	38	58	6	4.5	22	32	100	46	10	11	27	5.5	50	8	16	-	19	90°	34	20	M5
P52E/2	51	53	12	5.5	27	41	108	57	12	10	26	6.2	62	7.5	20	10	24	90°	42	25	M5
P52E/3	80	63	12	7.1	39	56	155	75	18	27	31	8.5	70	7.5	20	-	29	90°	52	32	G1/8
P52E/4	100	86	16	8.5	51	64	200	85	20	30	41.5	8.5	84	9	20	17.5	61	90°	62	40	G1/8

Kolbendurchmesser = erforderlicher Zylinderdurchmesser für F5 bei 6 bar