



ISO9001-2015国际质量  
管理体系认证企业



# PNEUMATIC & HYDRAULIC CLAMPS

## 气油压缸系列

Clamptek

PNEUMATIC & HYDRAULIC CLAMPS

气油压缸系列

CATALOGUE 2026



WWW.CLAMPTEK.COM

CATALOGUE 2026

台湾嘉刚国际股份有限公司  
CLAMPTEK ENTERPRISE CO.,LTD.(TAIWAN)  
TEL: +86-2-2707-5928  
FAX: +86-2-2707-6018  
E-mail:marketing@clamptek.com  
www.clamptek.com

东莞市嘉刚机电科技发展有限公司  
DONGGUAN CLAMPTEK ELECTRO-MECHANICAL SCIENCE & TECHNOLOGY DEVELOPING CO.,LTD

地址: 广东省东莞市洪梅镇望沙路洪梅段25号6栋、7栋、8栋  
Building 6, 7 and 8, No. 25, Hongmei Section, Wangsha Road,  
Hongmei Town, Dongguan City, Guangdong Province

TEL: 0769-38937833 85833143 85833142  
FAX: 0769-85833141 PC:523119  
E-mail: marketing@clamptek.com  
Web: www.clamptek.com



抖音官方号



微信公众号



Catalogue 2026 版权所有 翻印必究  
All Rights Reserved Print Out 2026

本公司对产品规格、设计特性均不断研究改进, 上述规格若有变更, 恕不另行通知。  
Specifications and design characteristics are subject to change without prior notice

# CLAMPING THE POWER TO CONTROL

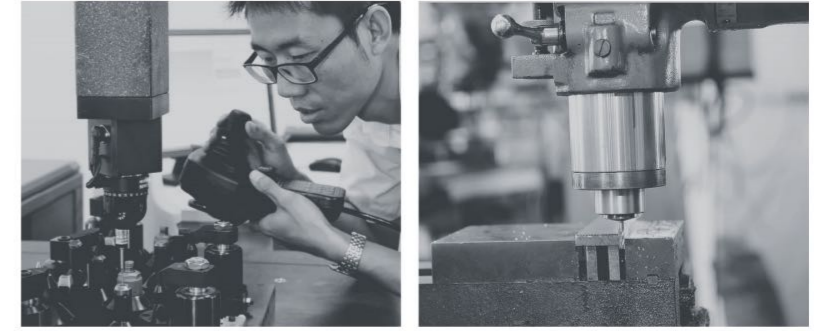

## INTRODUCTION 公司介绍

嘉刚的技术研发源于台湾,嘉刚总部位于台湾,生产基地设立于东莞。凭借着强大的产品开发、制造、销售能力,特别是在夹具夹持元件领域中获得客户对嘉刚品牌的认同与信赖,嘉刚人坚持不懈的辛勤努力,为中国的工业装备业作出巨大的贡献。嘉刚公司由邱魏聪哲先生在台湾创立,2003年为拓展市场进驻东莞厚街镇设立工厂。为适应业务增长,公司于2013年搬迁至东城桑园工业区以扩大生产规模,并计划于2026年迁至洪梅镇莞台高新产业园区,以实现新一轮的产业升级。嘉刚公司不仅生产肘节夹钳,还重点投入开发高精密气油压缸、液压站,并将产品服务线延伸到代理盈锡精密锁定螺母、东培精密轴承、弘旺联轴器及德国HALDER工装夹具配件。

The technical R&D of Clamptek originated in Taiwan where its headquarter is located. Clamptek has its production base located in Dongguan. Due to its strong power in product development, manufacturing and sales capacity, and gained the brand recognition and trust from clients. With perseverance and hard work, Clamptek has made significant contribution in the industrial equipment industry.

President Mike Tsung-Che Chiu Wei established Taiwan CLAMPTEK ENTERPRISE CO., LTD. and set up the factory in Houjie Town of Dongguan in 2003, in order to expand the production scale, the factories were transferred to the New Factory Area of Sangyuan Industrial Park of Dongcheng District of Dongguan City in 2013. It is also planned to move to the Guantai High-tech Industrial Park in Hongmei Town in 2026 to achieve a new round of industrial upgrading.

Clamptek uses the clamps as the tools for clamping and fixturing. It also efficiently organized the system of manual toggle clamps, pneumatic/hydraulic clamps, hydraulic power units and precision lock nut of Yinsh, precision bearing of TPI, HW Coupling and Halder's spring plungers all together.

# THEORETICAL CLAMPING FORCE CALCULATION FORMULA

## 夹持力计算公式

### 推拉缸理论出力计算

推力  $F = P \times A$     拉力  $F = P \times (A - a)$   
 F: 推拉缸夹持力 (kgf)  
 P: 使用压力 (kgf/cm<sup>2</sup>)  
 A: 活塞受力面积 (cm<sup>2</sup>)  
 a: 活塞杆直径面积 (cm<sup>2</sup>)

### PUSH-PULL CLAMPS FORCE CALCULATION FORMULA

Push  $F = P \times A$     Pull  $F = P \times (A - a)$   
 F: Push - pull force (kgf)  
 P: Operating pressure (kgf/cm<sup>2</sup>)  
 A: Operating pressure (cm<sup>2</sup>)  
 a: Piston rod area (cm<sup>2</sup>)

### 杠杆缸理论夹持力计算

$F = P \times A \times L1 \div L2$   
 F: 推拉缸夹持力 (kgf)  
 P: 使用压力 (kgf/cm<sup>2</sup>)  
 A: 活塞受力面积 (cm<sup>2</sup>)  
 L1: 活塞杆中心点至杠杆支撑点距离 (mm)  
 L2: 杠杆支撑点至压臂压点距离 (mm)

### PUSH-PULL CLAMPS FORCE CALCULATION FORMULA

$F = P \times A \times L1 \div L2$   
 F: Leverage clamp force (kgf)  
 P: Operating pressure (kgf/cm<sup>2</sup>)  
 A: Piston force area (cm<sup>2</sup>)  
 L1: The distance between piston rod centre point and leverage point (mm)  
 L2: The distance between leverage point and clamp arm clamp point (mm)

### 转角缸理论夹持力计算

$F = P \times A2 = P \times (A1 - a)$   
 F: 推拉缸夹持力 (kgf)  
 P: 使用压力 (kgf/cm<sup>2</sup>)  
 A: 活塞受力面积 (cm<sup>2</sup>)  
 a: 活塞杆直径面积 (cm<sup>2</sup>)  
 A2: 活塞受拉入端力面积 (cm<sup>2</sup>)

### SWING CLAMP FORCE CALCULATION FORMULA

$F = P \times A2 = P \times (A1 - a)$   
 F: Swing clamp force (kgf)  
 P: Operating pressure (kgf/cm<sup>2</sup>)  
 A1: Piston force area (cm<sup>2</sup>)  
 a: Piston rod area (cm<sup>2</sup>)  
 A2: Piston pull force area (cm<sup>2</sup>)

作动缸实际出力可以用上述公式计算结果乘上使用安全系数(一般建议实际出力为理论出力之60%~70%)

The practical clamping force of work clamps is 60% - 70% of theoretical clamping force.

	Pa	bar	kgf/cm <sup>2</sup>	atm	at	Torr	mmH <sub>2</sub> O	mmHg	Psi
1 Pa	1	0.00001	0.00001	0.00001	0.00001	0.0075	0.10197	0.0075	0.00014
1 bar	100000	1	1.01972	0.9869	1.01972	750.062	10.1972	750.062	14.504
1 Kgf/cm <sup>2</sup>	98066.5	0.98067	1	0.9678	1	735.6	10	735.6	14.22
1 atm	101325	1.01325	1.033	1	1.033	760	10.332	760	14.7
1 at	98067	0.98067	1	0.9678	1	735.6	10	735.6	14.22
1 Torr	133.3	0.00133	0.00136	0.00132	0.00136	1	13.6	1	0.01934
1 mmH <sub>2</sub> O	9.8067	0.000098	0.0001	0.0000968	0.0001	0.07356	1	0.07356	0.00142
1 mmHg	133.322	0.00133	0.00136	0.00132	0.00136	1	13.5951	1	0.01934
1 Psi	6894.76	0.06895	0.07031	0.06805	0.07031	51.7149	703.07	51.7149	1

转角缸转角方向是指下压时转角方向。

Note: The swing direction is defining under clamping condition.

## SINGLE SIDE SWING CLAMP

### 单边压板旋转示意图

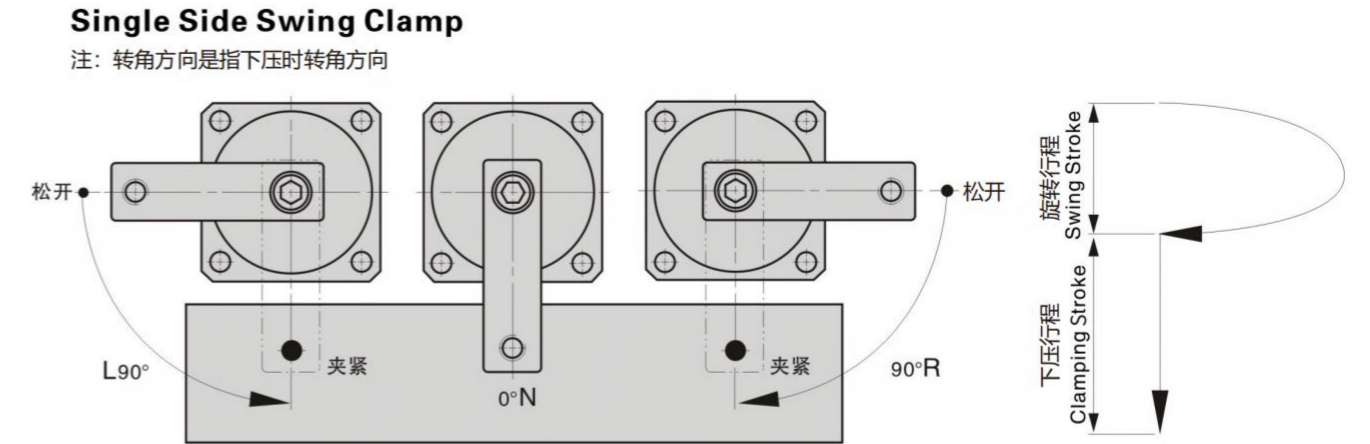

## DOUBLE SIDE SWING CLAMP

### 双边压板旋转示意图

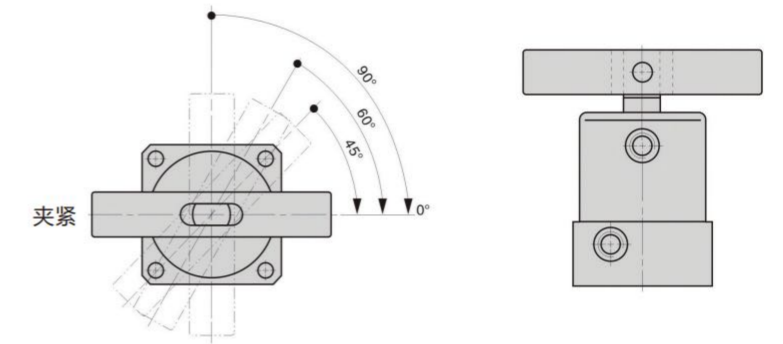

## CLAMPING ARM MOUNTING METHODS

### 压板锁紧操作方式



## CLAMPING ARM REMOVAL METHODS

### 压板拆卸操作方式



# INDEX 产品目录索引

## HYDRAULIC LEVERAGE CLAMPS







油压杠杆缸系列

<p><b>180法兰型传感器内置式油压缸 (鹰嘴缸)</b> 180 Flange type air sensor built-in hydraulic compact clamp 011-014 ★</p> 	<p><b>CVLKW气检式油压杠杆缸</b> CVLKW Air sensing leverage clamp ★ 015-022</p> 	<p><b>CLKW 传感器内置式杠杆缸</b> CLKW Air sensing leverage clamp ★ 023-032</p> 	<p><b>CLKA 高动力 &amp; 扎实型杠杆油压缸</b> CLKA Hydraulic leverage clamp ★ 033-038</p> 	<p><b>CLKA-P 高动力 &amp; 扎实型杠杆油压缸</b> CLKA-P Hydraulic leverage clamp ★ 039-040</p> 	<p><b>C360紧凑型杠杆油压缸</b> C360 Hydraulic leverage clamp ★ 041-042</p> 	<p><b>CGL多爪杠杆式油压缸</b> CGL Multi-claw hydraulic leverage clamp ★ 043-046</p> 
<p><b>CBLU 方块&amp;紧凑型杠杆式油压缸</b> CBLU Hydraulic leverage clamp ★ 047-048</p> 	<p><b>CLF5H 连杆气油压缸 (眼镜蛇缸)</b> CLF5H Pneumatic / hydraulic leverage clamp ★ 049-052</p> 	<p><b>CHLC 杠杆式油压缸</b> CHLC Hydraulic leverage clamp 053-056</p> 	<p><b>LHC01 杠杆式油压缸</b> LHC01 Hydraulic leverage clamp 057-058</p> 	<p><b>YCGF 单动外螺纹杠杆式油压缸</b> YCGF Single-action external thread leverage clamp 059-060 ★</p> 	<p><b>CCLT 紧凑型单动杠杆式油压缸</b> CCLT Single acting leverage clamp ★ 061-062</p> 	<p><b>CLM 单动杠杆式油压缸</b> CLM Single acting hydraulic leverage clamp 064-066 ★</p> 
<p><b>CCG 微型杠杆油缸</b> CCG Miniature leverage clamp ★ 067-068</p> 	<p><b>CCLV 单动高压杠杆缸</b> CCLV Hydraulic single action leverage clamp (High pressure) ★ 069-070</p> 	<p><b>CTMA 高压复动杠杆油压缸</b> CTMA Hydraulic double action leverage clamp (High pressure) ★ 071-074</p> 	<p><b>CCLW 高压紧凑型杠杆式油压缸</b> CCLW High pressure leverage clamp ★ 075-076</p> 	<p><b>CYS 摇臂式油压杠杆缸</b> CYS Rocker hydraulic leverage clamp ★ 077-078</p> 	<p><b>CLP 空心式夹紧器</b> CLP Hollow clamp ★ 079-080</p> 	

## HYDRAULIC SWING CLAMPS

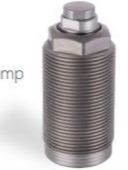
油压转角缸系列

<p><b>CHA 油压转角缸</b> CHA Hydraulic swing clamp ★ 081-090</p> 	<p><b>CLHW 传感器内置式转角缸</b> CLHW Air sensing swing clamp ★ 091-098</p> 	<p><b>CHA-P 油压转角缸</b> CHA-P Hydraulic swing clamp ★ 099-100</p> 	<p><b>CBTU 方块形油压转角缸</b> CBTU Hydraulic swing clamp ★ 101-102</p> 	<p><b>CHA/CHA-P/CBTU 压臂尺寸</b> Clamping arm accessories 103-105</p>	<p><b>CHS 油压转角缸</b> CHS Hydraulic swing clamp 107-116</p> 	<p><b>CPF 平行油压转角缸</b> CPF Hydraulic swing clamp 117-118</p> 		
<p><b>CTLA 高压转角缸</b> CTLA High pressure hydraulic swing clamp ★ 119-123</p> 	<p><b>CTLA-M 复动高压气压检测转角缸</b> CTLA-M Double acting with high pressure air sensing swing clamp ★ 125-126</p> 	<p><b>CTLB 高压转角缸</b> CTLB High pressure hydraulic swing clamp ★ 127-132</p> 	<p><b>NFS 高压转角缸</b> NFS High pressure hydraulic swing clamp 133-136</p> 	<p><b>030 底部法兰转角缸</b> 030 Hydraulic swing clamp 137-138</p> 	<p><b>050 顶部法兰转角缸</b> 050 Hydraulic swing clamp 139-140</p> 	<p><b>HPS 高压转角缸</b> HPS Hydraulic swing clamp 141-142</p> 		
<p><b>SGYT-30 三杆一体旋转油压缸</b> SGYT-30 Three-rod rotary hydraulic swing clamp ★ 143</p> 	<p><b>S106 转向节专用油压转角缸</b> S106 Special hydraulic corner cylinder for steering knuckle ★ 144</p> 	<p><b>CYZT-63-64 中心涨套油缸</b> CYZT Central expansion sleeve cylinder ★ 145-146</p> 	<h2 style="margin: 0;">HYDRAULIC SUPPORT CLAMPS</h2> <p style="margin: 0;">油压支撑缸系列</p>			<p><b>CSP 油压支撑缸</b> CSP Hydraulic support clamp ★ 147-162</p> 	<p><b>YX 支撑缸伸缩底座</b> YX Support cylinders telescopic base ★ 163-164</p> 	<p><b>CSF 上法兰油压支撑缸</b> CSF Hydraulic support clamp ★ 165-172</p> 

<p><b>CSF-P 上法兰油压支撑缸</b> CSF-P hydraulic support clamp ★ 173-176</p> 	<p><b>CTNC 高压支撑缸系列</b> CTNC High pressure hydraulic support clamp ★ 177-180</p> 	<p><b>CHP 高压支撑缸</b> CHP High pressure hydraulic support clamp ★ 181-184</p> 	<p><b>CSP 油压支撑缸 (高压)</b> CSP Hydraulic support clamp (High pressure) ★ 185-186</p> 	<p><b>HSP 油压支撑缸 高压系列</b> HSP Hydraulic support clamp (High pressure) ★ 187-188</p> 	<p><b>SP-AH 气油两用支撑缸</b> SP-AH Pneumatic / hydraulic support clamp 189-190</p> 
--	---	--	--	--	---





























注 ★ 为亮点产品系列。 ★ It means "Highlight" product.

# INDEX 产品目录索引

<b>HYDRAULIC LINEAR CYLINDERS</b> 直线油缸系列	<b>CLLW内置气检式油压直线缸</b> CLLW Air sensor built-in linear cylinder 191-194 ★	<b>CLL油压紧凑型直线缸</b> CLL Hydraulic compact linear cylinder ★ 195-208	<b>CCNA油压紧凑型直线缸</b> CCNA Hydraulic compact linear cylinder ★ 209-212	<b>DBA&amp;DBC紧凑型直线型油压缸</b> DBA&DBC Compact linear hydraulic cylinder ★ 213-215	<b>CHTB薄型油压缸</b> CHTB Hydraulic push-pull cylinder 217-225	<b>HBC块型油压缸</b> HBC Hydraulic block cylinder 227-228	<b>CLSA侧向夹紧器</b> CLSA Side damp ★ 229-230	
	<b>CTLZ下拉式涨紧缸</b> CTLZ Pull Stud Clamp ★ 231-234	<b>CFP油压钢球锁紧下拉缸</b> CFP Hydraulic pull stud clamp 235-237	<b>CYTH单动型直线油压缸</b> CYTH Single acting hydraulic cylinder ★ 238	<b>ZERO POINT SYSTEM AND HYDRAULIC EXPANSION LOCATION PIN</b> 零点定位器与扩径定位销系列			<b>CZP零点定位器</b> CZP Zero point system ★ 239-248	<b>CVM油压扩径定位销</b> CVM Hydraulic expansion location pin ★ 249-253
	<b>CTC外螺纹小型油压单动缸</b> CTC Hydraulic thread cylinder 255-256	<b>CTC-K外螺纹小型油压单动缸</b> CTC-K Hydraulic thread cylinder ★ 257-258	<b>CTC-P外螺纹小型油压单动缸</b> CTC-P Hydraulic thread cylinder ★ 259-260	<b>CTC-PD外螺纹小型油压单动缸</b> CTC-PD Hydraulic thread cylinder ★ 261-262				
	<b>HYDRAULIC SINGLE CYLINDERS</b> 单动缸系列							
<b>VALVES</b> 阀系列	<b>CLG油压顺序阀</b> CLG Hydraulic sequence valve ★ 263-264	<b>SV-AT1时间顺序阀</b> SV-AT1 Time sequence valve 265	<b>CZL调速阀(低压力) 日系油压缸专用</b> CZL Speed control valve(low pressure) ★ 267-268	<b>CZT速度控制阀(高压用)</b> CZT Speed control valve(high pressure) ★ 269-270	<b>CVCF速度控制阀(低压力)</b> CVCF Speed control valve(low pressure) ★ 271-272	<b>CVCH速度控制阀(高压用)</b> CVCH Speed control valve(high pressure) ★ 273-274	<b>CSV/CLSV油压顺序阀</b> CSV/CLSV Hydraulic sequence valve 275	
	<b>CFCV/CFTC油压流量阀</b> CFCV/CFTC Hydraulic flow control valve 276	<b>CPRV油压减压阀</b> CPRV Hydraulic pressure reducing valve 277	<b>引导式减压阀</b> Pilot operated reducing valves 279-280	<b>引导式顺序阀</b> Pilot operated sequence valve 281-282	<b>CWD-B气动顺序阀</b> CWD-B Pneumatic sequence valve 283-284			
	<b>ROTARY JOINT &amp; OTHER HYDRAULIC PRODUCTS</b> 旋转接头及其它油压系列							
	<b>CVP无泄漏接头</b> CVP leak-free joint ★ 285	<b>CJRA旋转接头</b> CJRA Rotary joint ★ 286-292	<b>CJRB旋转接头</b> CJRB Rotary joint ★ 293-298	<b>CJRC旋转接头</b> CJRC Rotary joint ★ 299-304	<b>CJRD旋转接头</b> CJRD Rotary joint ★ 305-308	<b>CRA旋转接头</b> CRA Rotary joint ★ 309-312	<b>CRAF由路旋转接头</b> CRAF Hydranic rotary joint ★ 313-314	
<b>CRA-HS快速旋转接头</b> CRA-HS Quick rotary joint ★ 315-316	<b>HB油压增压器</b> HB Hydraulic booster with sequence valve 317-318	<b>CJSS弹簧式蓄能器</b> CJSS Spring accumulator 319-322	<b>ADB-A储能器</b> ADB-A Accumulator 323-324	<b>CMO轻型油压缸</b> CMO Hydraulic cylinder 325-329	<b>CHO重型油压缸</b> CHO Hydraulic cylinder 331-337	<b>CFO可调缓冲油压缸</b> CFO 14 MPa Adjustable cushioning hydraulic cylinder 339-343		

注: ★ 为亮点产品系列。 ★ It means "Highlight" product.

# INDEX 产品目录索引

<p>CRO圆型油压缸 CRO Hydraulic cylinder</p>  <p>345-350</p>	<p>CMO/CHO/CRO/CFO油压缸轴心配件 CMO/CHO/CRO/CFO Series hydraulic cylinder axis accessories</p> <p>351-352</p>	<p>CGO重型油压缸 CGO 21 MPa Tie-rod hydraulic cylinder</p>  <p>353-360</p>	<p>CHRO大型油压缸 CHRO 21 MPa Roud hydraulic cylinder</p>  <p>361-367</p>	<p>CHSG焊接高压缸 CHSG Hydraulic cylinder</p>  <p>369-374</p>	<p>CHK柱型模具缸 CHK Column-type hydraulic cylinder</p>  <p>375-378</p>	<p>CP同步油缸 CP Synchronous clamp cylinder</p>  <p>★ 379-380</p>	<p>CFVA对心夹 CFVA Clamping cylinder</p>  <p>★ 381-382</p>			
<p>CYTC-S20下拉式台钳 CYTC-S20 pull-down bench vise</p>  <p>★ 383</p>	<p>ROA夹紧油缸 ROA Clamping cylinder</p>  <p>384</p>	<p>自动平衡系统 Auto balance system</p>  <p>385-386</p>	<p>非标工程缸 (重型油压缸) Non-standard hydraulic cylinder</p>  <p>387</p>							
<p><b>PNEUMATIC LEVERAGE CLAMPS</b> 气压杠杆缸系列</p>		<p>CALC/YALC/YJGL 杠杆式气压缸 CALC/YALC/YJGL Pneumatic leverage clamp</p>  <p>★ 388-390</p>	<p>CPLCU气压杠杆缸 CPLCU Pneumatic leverage clamp</p>  <p>★ 391-392</p>	<p><b>PNEUMATIC SWING CLAMPS</b> 气压转角缸系列</p>		<p>ASC气压转角缸 ASC Pneumatic swing clamp</p>  <p>393-396</p>	<p>NAU上法兰气路板型气压转角缸 NAU Pneumatic swing clamp</p>  <p>397-398</p>	<p>PB感应式气压转角缸 PB Pneumatic swing clamp</p>  <p>399-400</p>	<p>PSB气压块状转角缸 PSB Pneumatic swing clamp</p>  <p>401-402</p>	
<p><b>PNEUMATIC SUPPORT CLAMPS</b> 气压支撑缸系列</p>		<p>CSW气压支撑缸 CSW Pneumatic support clamp</p>  <p>★ 403-405</p>	<p>CSW-25/32 气压支撑缸 CSW-25/32 pneumatic support clamp</p>  <p>★ 406</p>	<p>CSWC气动吸盘支撑缸 CSWC Pneumatic suction cup support clamp</p>  <p>★ 407-408</p>	<p><b>THIN TYPE ALUMINIUM ALLOY PNEUMATIC CYLINDERS</b> 薄型铝合金气缸系列</p>		<p>UCQ2薄形铝合金气缸 UCQ2 Thin-type pneumatic cylinder</p>  <p>409-414</p>	<p>SDA薄型铝合金气缸 SDA Thin-type pneumatic cylinder</p>  <p>415-419</p>	<p>DE无拉杆式铝合金缸 DE Pneumatic cylinder</p>  <p>421-424</p>	
<p><b>OTHER CYLINDERS</b> 其它气缸</p>		<p>CTK夹紧气缸 CTK Clamp pneumatic cylinder</p>  <p>425-426</p>	<p>机械夹爪 Grippers</p>  <p>★ 427</p>			<p><b>PNEUMATIC PUMPS</b> 气动泵系列</p>		<p>AHP气动增压泵 AHP Liquid-gas conversion booster pump</p>  <p>429-430</p>		
<p><b>ACCESSORIES</b> 其它附件系列</p>		<p>螺杆 Clamping screw</p>  <p>431-436</p>	<p>压板 Block-clamp</p>  <p>437-438</p>	<p>030/050/CHS压臂 030/050/CHS Clamping arm</p> <p>439-440</p>	<p><b>产品重量表</b> Product weight</p> <p>441-442</p>					

注: ★ 为亮点产品系列。 ★ It means "Highlight" product.

# 180

## 上法兰型传感器内置式油压缸

### UPPER FLANGE TYPE AIR SENSOR BUILT-IN HYDRAULIC COMPACT CLAMP



#### 产品特性

1. 此系列油缸具有高夹紧力与高刚性,并大幅度扩大了加长型压板的使用范围,占用空间小。
2. 操作方便,安全系数高,高压条件下也能发挥高密封性能,油缸通过气检开关向终端控制箱发出信号,就能知道油缸处于夹紧或松开状态。

最大操作压力: 250kgf/cm<sup>2</sup>  
 最小操作压力: 20kgf/cm<sup>2</sup> (无气检时)  
 最小操作压力: 70kgf/cm<sup>2</sup> (有气检时)

#### 注意事项

夹紧及放松动作需适当放缓,为进行确认动作,需设置空气传感器。气口需排气,务必防止冷却液、切削渣的侵入,使用时请保持向气口供气状态。

#### FEATURES

1. This series of clamps has high clamping force and high rigidity, which greatly expands the use of the elongated clamping plate, little space for installation.
2. Easy operation with high safety, high sealing performance can also be used under high pressure conditions, the clamp send a signal to the terminal control box through the air sensors, then you can know that the clamps in the clamping or unclamping state.

Max. operating pressure: 250kgf/cm<sup>2</sup>  
 Min. operation pressure: 20kgf/cm<sup>2</sup> (without air sensors)  
 Min. operation pressure: 70kgf/cm<sup>2</sup> (with air sensors)

#### NOTE

Clamping/unclamping actions need to be slowed down appropriately, and an air sensor should be set up for confirmation. The air outlet needs to exhaust. Be sure to prevent the intrusion of coolant and cutting slag, keep the air inlet in the supply state when using.

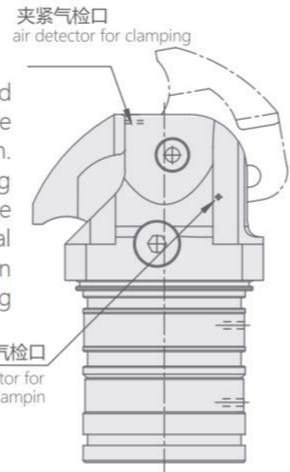

注: 该系列油缸夹紧气检和松开气检不能同时存在  
 Note: The detection for clamping and unclamping of this series can not exist at the same time.

#### 订购标示法 ORDERING INDICATION

示例: 1804-1101A

180	系列Series	180
4	大小(参照规格表) Size(please refer to specification)	1/2/3/4
1	上法兰型 Upper flange type	
10	压臂类型 Type for clamping arm	10(标准短压臂) Standard short clamping arm 30(标准长压臂) Standard long clamping arm *产品不附带压臂 The product didn't include damping arm
1	本体类型 Body type	1(本体带后盖) Body with cover 2(本体不带后盖) Body without cover
A	检测类型 Detection type	A: 放松检测 Detection for unclamping B: 无检测 Without detection 无字母: 夹紧和过夹紧检测 No letter: Clamping and with clamping detection

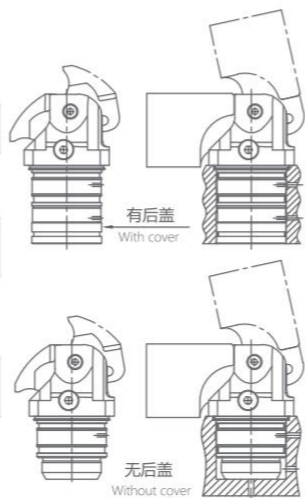

型号	理论夹持力(短压板, 油压在25MPa)	最大行程	夹紧行程	缸径	活塞杆径	夹紧受压面积	松开受压面积	推荐使用空气压力	使用温度(°C)
MODEL	CLAMPING FORCE AT 25MPa(KN)	MAX. STROKE (mm)	CLAMPING STROKE(mm)	CYLINDER DIAMETERΦ(mm)	ROD DIAMETER Φ(mm)	EFF.PISTON AREA CLAMP(cm <sup>2</sup> )	EFF.PISTON AREA UNCLAMP(cm <sup>2</sup> )	RECOMMENDED AIR PRESSURE(MPa)	RANGE OF TEMPERATURE(°C)
1801-1XX	2.5	5	4.5	18	11	2.3	3.6	0.3~0.6	0~70
1802-1XX	4.0	5	4.5	22	14	3.2	5.4	0.3~0.6	0~70
1803-1XX	7.5	7	6.5	28	17	6.4	10.2	0.3~0.6	0~70
1804-1XX	10.5	8.5	8	33	19	10.5	15.7	0.3~0.6	0~70

使用流体: 相当于ISO黏度等级的ISO-VG-32一般液压油 Usable fluid: Recommended: ISO-VG-32 hydraulic oil equivalent to ISO viscosity grade

#### 外形尺寸图 External Dimensions

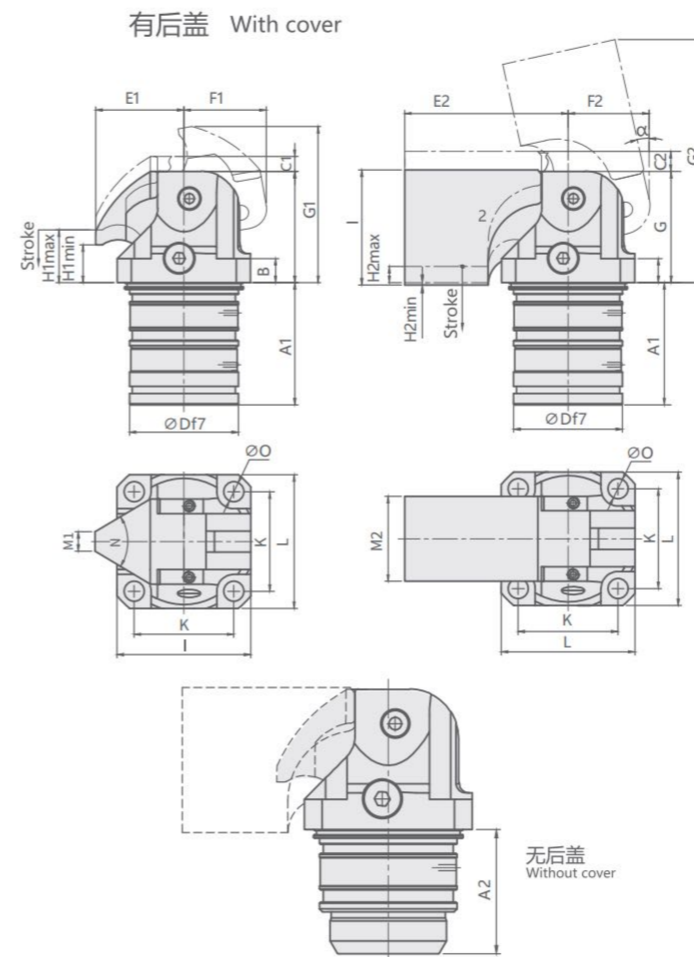

#### 安装孔加工图

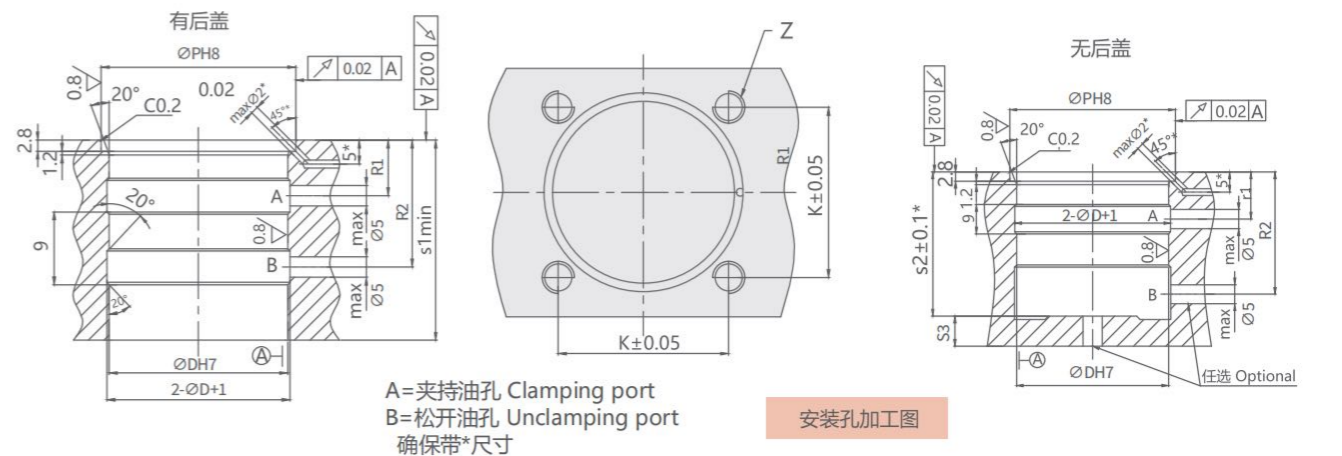

#### 外形尺寸表

型号 Model	1801-1XX	1802-1XX	1803-1XX	1804-1XX
α±1	13.5°	10.5°	15°	16°
A1	39.5	43	48.5	50.5
A2	31.5	34	40	40.5
B	6	7	10	10
C1	5	5	7	8.5
C2	14	12	7	8.5
ØDH7/f7	25	32	40	45
E1	27	28	36.5	36.5
E2	59	60	67.5	67.5
F1	25	26	32	35
F2	32	31	32	35
G	32.5	36.5	43	46
G1max	49.6	51	63.5	65.5
G2min/max	84.5/87.5	86/89.5	98.7/99.7	101/103
H1max	20	20	22	23.5
H1min	15.5	15.5	15.5	15.5
H2max	3.5	2.5	5.5	7
H2min	1	2	1	1
I	43	46	44.5	47.5
K	25	31	36.5	41
L	34	42	48	55
M1	5	6	8	8
M2	19	24	32	35
N	47.2°	55.8°	56.1°	62°
ØO	5.2	6.2	6.2	8.2
ØPH8	29	36	44	49
R1	13	13	14	14
R2	28	28	31	31
S1min	40	43.5	49	51
S2±0.1	32.1	34.1	40.7	40.9
S3min	6	7	9	10
Z	M5	M6	M6	M8

# 180

## 下法兰型传感器内置式油压缸

### DOWN FLANGE TYPE AIR SENSOR BUILT-IN HYDRAULIC COMPACT CLAMP



#### 产品特性

1. 此系列油缸具有高夹紧力与高刚性,并大幅度扩大了加长型压板的使用范围,占用空间小。
2. 操作方便,安全系数高,高压条件下也能发挥高密封性能,油缸通过气检开关向终端控制箱发出信号,就能知道油缸处于夹紧或松开状态。

最大操作压力: 250kgf/cm<sup>2</sup>  
 最小操作压力: 20kgf/cm<sup>2</sup> (无气检时)  
 最小操作压力: 70kgf/cm<sup>2</sup> (有气检时)

#### FEATURES

1. This series of clamps has high clamping force and high rigidity, which greatly expands the use of the elongated clamping plate, little space for installation.
2. Easy operation with high safety, high sealing performance can also be used under high pressure conditions, the clamp send a signal to the terminal control box through the air sensors, then you can know that the clamps in the clamping or unclamping state.

Max. operating pressure: 250kgf/cm<sup>2</sup>  
 Min. operation pressure: 20kgf/cm<sup>2</sup> (without air sensors)  
 Min. operation pressure: 70kgf/cm<sup>2</sup> (with air sensors)



#### 注意事项

夹紧及放松动作需适当放缓,为进行确认动作,需设置空气传感器。气口需排气,务必防止冷却液、切削渣的侵入,使用时请保持向气口供气状态。

#### NOTE

Clamping/unclamping actions need to be slowed down appropriately, and an air sensor should be set up for confirmation. The air outlet needs to exhaust. Be sure to prevent the intrusion of coolant and cutting slag, keep the air inlet in the supply state when using.

#### 订购标示法 ORDERING INDICATION

示例: 1804-210C

180	系列Series	180
4	大小(参照规格表) Size(please refer to specification)	2/3/4
2	下法兰型 Down flange type	
10	压臂类型 clamping arm type	10: 标准短压臂 Standard short clamping arm 30: 标准长压臂 Standard long clamping arm *产品不附带压臂 The product didn't include clamping arm
C	检测类型 Detection type	A: 放松检测 Detection for unclamping B: 无检测 Without detection C: 夹紧和松开检测 Detection for clamping and unclamping 无字母: 夹紧和过夹紧检测 No letter: Clamping and with clamping detection

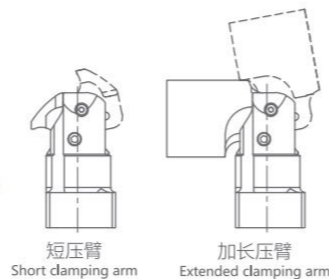

型号	油缸能力 (油压25MPa时)	夹紧力 (油压25MPa时)	夹紧臂长度	最大行程	夹紧行程	内径Φ	杆径Φ	夹紧油量	松开油量	最大流量	空气压力 调节范围	使用温度 范围
MODEL	CYLINDER CAPACITY AT 25MPa(kN)	CLAMPING FORCE AT AT 25MPa(kN)	LENGTH OF CLAMPING ARM(mm)	MAX. STROKE (mm)	CLAMPING STROKE(mm)	INSIDE DIAMETERΦ(mm)	ROD DIAMETERΦ(mm)	OIL CAPACITY CLAMP(cm <sup>3</sup> )	OIL CAPACITY UNCLAMP(cm <sup>3</sup> )	MAX. FLOW RATE (cm <sup>3</sup> )	RANGE OF AIR PRESSURE ADJUSTMENT(MPa)	RANGE OF TEMPERATURE(°C)
1802-2XX	4	3.7	28	5	4.5	22	14	3.2	5.4	5.5	0.3~0.6	0~70°C
1803-2XX	7.5	7.3	36.5	7	6.5	28	18	6.4	10.2	11	0.3~0.6	0~70°C
1804-2XX	10.5	10.2	36.5	8.5	8	33	19	10.5	15.7	25	0.3~0.6	0~70°C

#### 外形尺寸图 External Dimensions

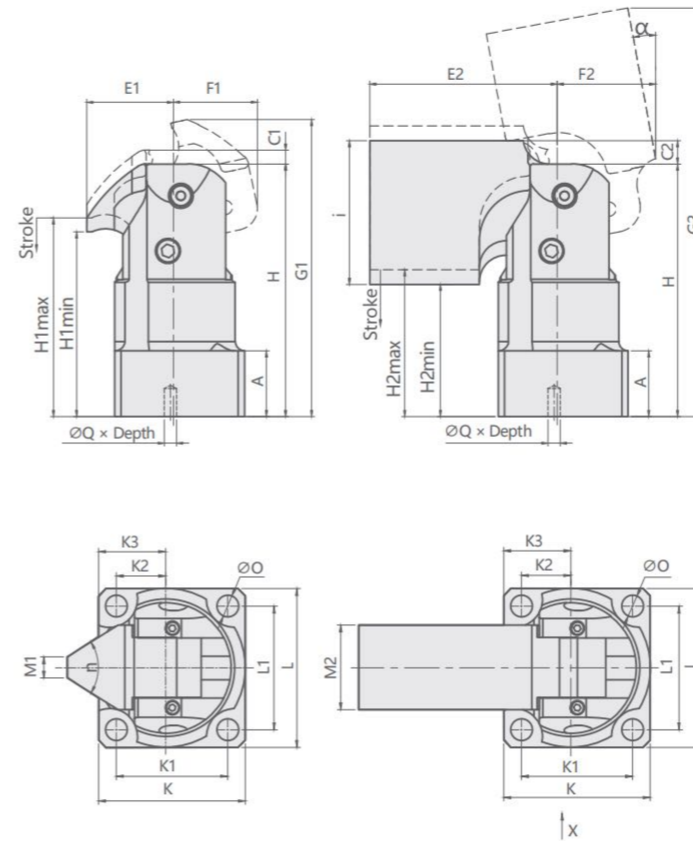

#### 安装孔加工图

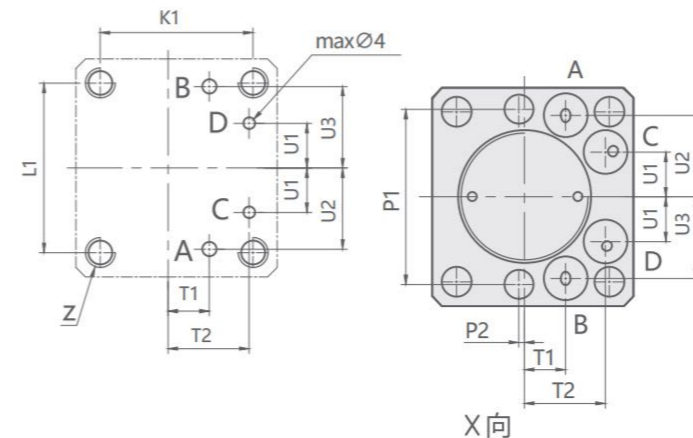

#### 外形尺寸表

Unit:mm

型号 Model item	1802-2XX	1803-2XX	1804-2XX
α±1°	10.5°	15°	16°
A	21	24	24
C1	5	7	8.5
C2	12	7	8.5
E1	28	36.5	36.5
E2	60	67.5	67.5
F1	26	32	35
F2	31	32	35
G1min./max	95.1/95.4	115/9	117.5
G2min./max	130.5/133.8	150.9/152	153.6/155.6
H	80.8	95.4	98.6
H1max	64.3	74.4	76.1
H1min	59.8	67.9	68.1
H2max	46.8	57.9	59.6
H2min	42.3	51.4	51.6
I	46	44.5	47.5
K	41.5	52	54
K1	31.5	38	41
K2	14	16	18
K3	19	23	24.5
L	45	58	59
L1	35	44	46
M1	6	8	8
M2	24	32	35
N°	55.8°	56.1°	62°
∅O	6.2	8.2	8.2
P1±0.02	35	44	48
P2±0.1	0	0	3
∅Q+0.05xD	6x9	8x17	8x17
T1	8.5	10	11
T2	16.7	21.5	21.2
U1	9.2	12.5	13.5
U2	16.8	20	23
U3	16.8	20	22
Z	M6	M8	M8

A=夹持油孔 Clamping port  
 B=松开油孔 Unclamping port  
 C=夹紧气检口 Clamping monitoring  
 D=松开气检口 Unclamping monitoring

# CVLKW

## 传感器内置式杠杆缸

# CVLKW AIR SENSOR BUILT-IN HYDRAULIC LEVERAGE CLAMP



### 产品特性

该系列产品是在CLKW系列产品的基础上进行优化设计，安装与空气输出方式更加简洁，通过连接空气传感器，检出差压，实现确认动作，通过夹紧动作确认，能实现安全可靠地将工件搬入搬出。

最大操作压力: 70kgf/cm<sup>2</sup>

最小操作压力: 5kgf/cm<sup>2</sup>

### FEATURES

The CVLKW series is an optimized design based on the CLKW series. The installation and air output methods are more simplified. It also air sensing mechanisms by detecting the differential pressure to achieve action confirmation, allowing safe and efficient loading/unloading of the workpiece.

Max. operating pressure: 70kgf/cm<sup>2</sup>

Min. operating pressure: 5kgf/cm<sup>2</sup>

### 注意事项

- 1.请不要堵塞排气口，必须向大气开放。
- 2.请注意防止冷却液及铁屑等从排气口侵入。

### Note

- 1.Please do not block the exhaust port. It must be open to the atmosphere.
- 2.Please keep clearance of the air exhaust hole to prevent the intrusion of coolant and chips

### 订购标示法 ORDERING INDICATION

示例: CVLKW-048CER

CVLKW	系列 Series	CVLKW
<b>048</b>	主体尺寸 Body size	040: ΦHD=40mm 065: ΦHD=65mm 048: ΦHD=48mm 075: ΦHD=75mm 055: ΦHD=55mm ΦHD表示本体油缸外径尺寸 Outer diameter (ΦHD) of the cylinder
<b>C</b>	板式连接型 (附带G螺纹堵头) Gasket Option(With G Thread Plug)	附带G螺纹堵头可安装速度控制阀 (CZL) (用户另行购买) With G Thread Plug(able to attach Speed Control Valve) (Order the valve separately Recommended:CZL)
<b>E</b>	传感阀符号 Sensing Valve	E: 夹紧,释放动作确认型 E: Clamp-Unclamp Confirmation(Both) H: 夹紧动作确认型 H: Clamp Confirmation Only J: 释放动作确认型 J: Unclainp Confirmation Only
<b>R</b>	压臂安装方向 Lever direction	L: 左 L: Left 空白: 中间 Blank: Center R: 右 R: Right

注: 推荐使用气缸0.1-0.2MPa,空气检测器为SMC的ISA2-HE45N.  
Note: Recommended operating air pressure 0.1-0.2MPa, air sensor: SMC ISA2-HE45N.

### 规格参数表 SPECIFICATIONS

型号	理论夹持力 (70kgf/cm <sup>2</sup> )	夹紧行程	总行程	推出容积	拉入容积	推出受压面积	拉入受压面积	使用温度范围	使用流体
MODEL	CLAMPING FORCE AT 70kgf/cm <sup>2</sup> (Kgf)	CLAMPING STROKE (mm)	TOTAL STROKE(mm)	CYLINDER CAPACITY CLAMP(cm <sup>3</sup> )	CYLINDER CAPACITY UNCLAMP(cm <sup>3</sup> )	EFF.PISTON AREA CLAMP(cm <sup>2</sup> )	EFF.PISTON AREA UNCLAMP(cm <sup>2</sup> )	RANGE OF TEMPERATURE(°C)	USABLE FLUID
CVLKW-040	290	17.5	20.5	10.9	8.6	5.31	4.17	0±70°C	相当于ISO粘度等级的ISO-VG-32一般液压油 Recommended: ISO-VG-32 hydraulic oil equivalent to ISO viscosity grade
CVLKW-048	389	20.5	23.5	16.6	13	7.07	5.52	0±70°C	
CVLKW-055	487	23	26	25.0	19.8	9.62	7.62	0±70°C	
CVLKW-065	852	26.5	29.5	46.9	37.7	15.9	11.76	0±70°C	
CVLKW-075	1332	32	35	83.2	69.8	23.8	20	0±70°C	

### 动作原理(剖面结构)

※ 本图表示夹紧,释放动作确认型(Model CVLKW-CE□)

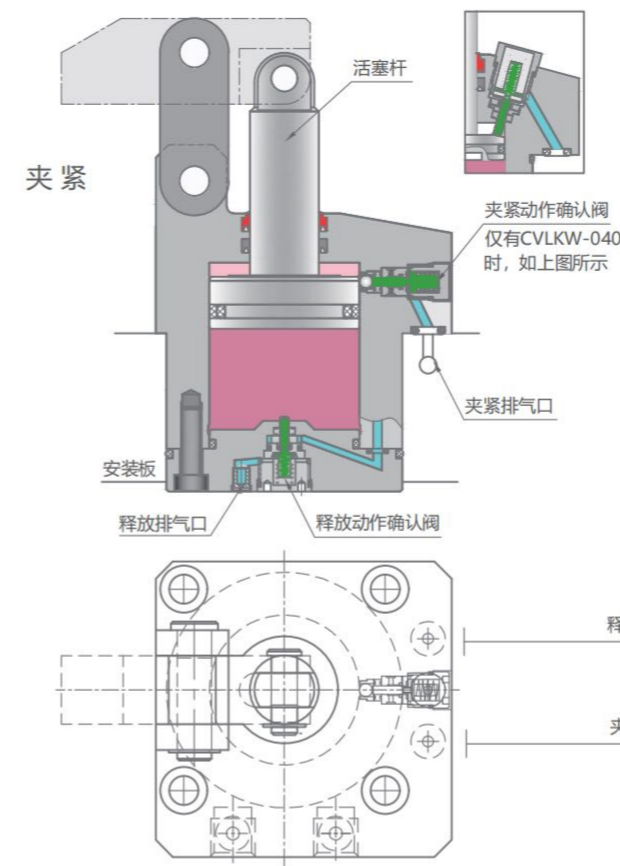

夹紧(向夹紧用供油口供给油压时)  
活塞杆边上升, 夹紧工件。

※ 仅有CVLKW040在此状态下解除夹紧侧的油压供给时, 活塞杆有可能在内置弹簧的作用下发生微动。

油压		空气传感器	
夹紧油压	释放油压	夹紧动作确认	释放动作确认
ON	OFF	ON	OFF

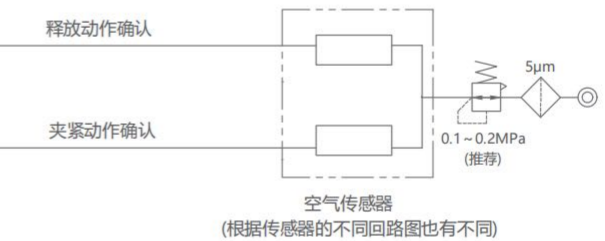
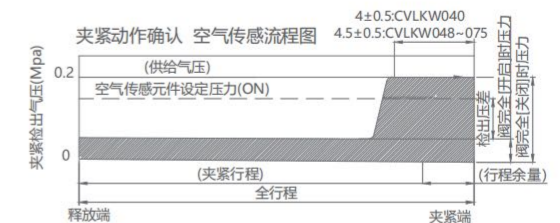

### 释放

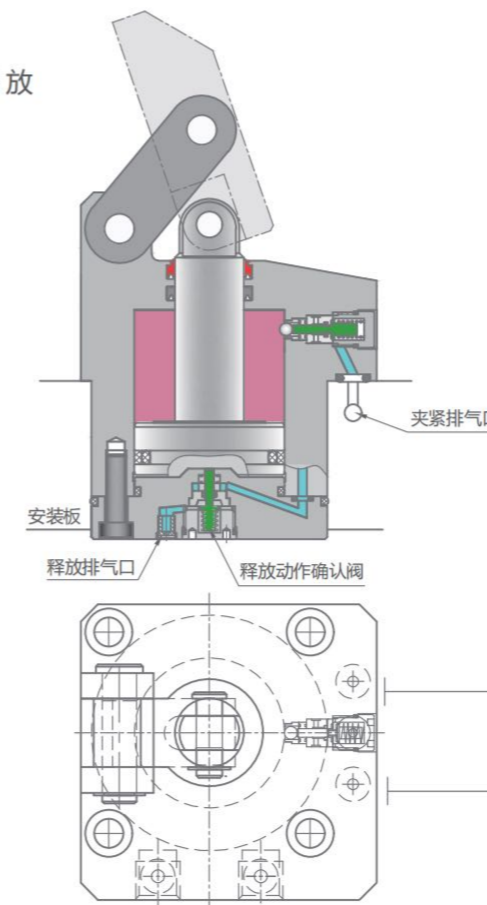

释放(向释放用供油口供给油压时)  
活塞杆下降。

※ 在此状态下解除释放侧的油压供给时, 活塞杆有可能在内置弹簧的作用下发生微动。

油压		空气传感器	
夹紧油压	释放油压	夹紧动作确认	释放动作确认
OFF	ON	OFF	ON

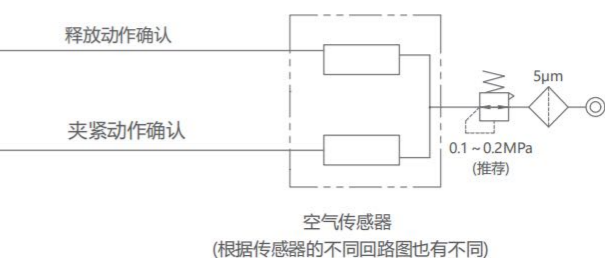
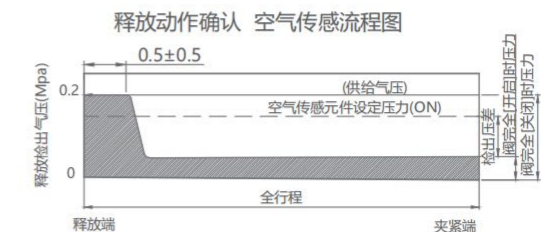

## 外形尺寸图 External Dimensions

• 本图表示CVLKW-CE的夹紧状态

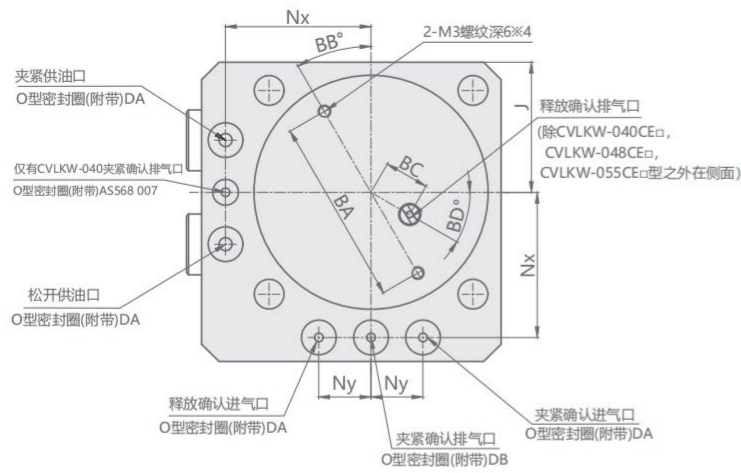

## 夹紧·释放动作确认型 Clamp-Unclamp Confirmation

• 本图表示CVLKW-CE的夹紧状态  
The drawing shows the unclamped state of CVLKW-CE

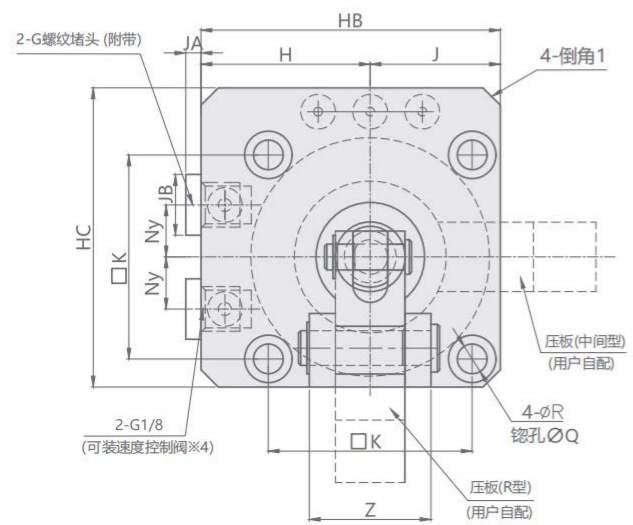
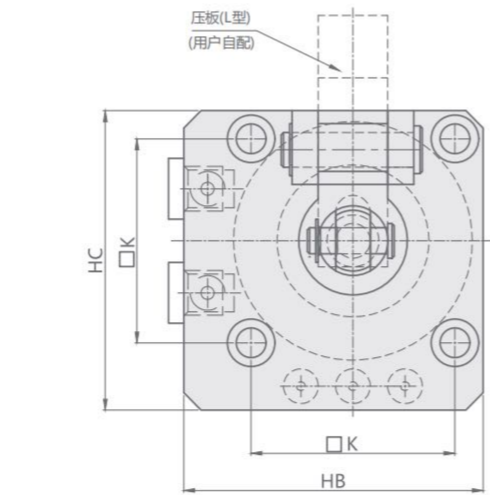
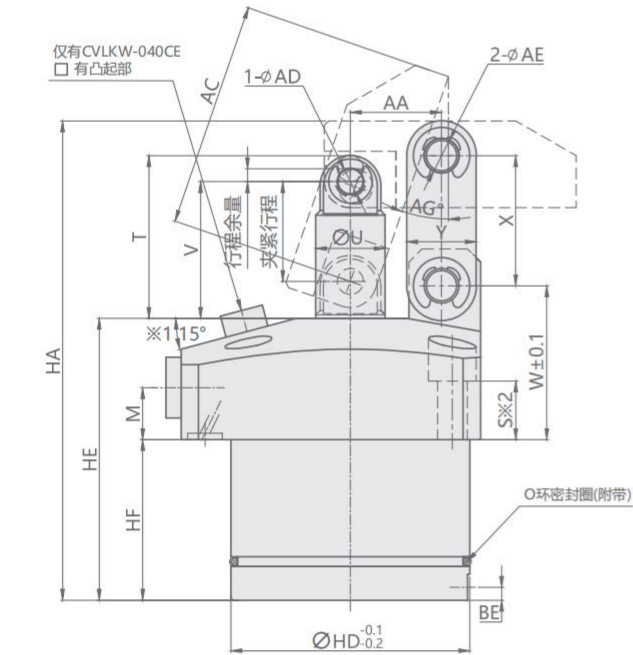
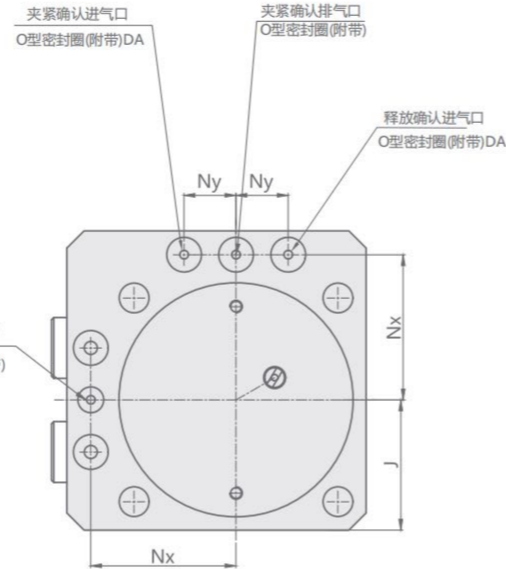

### 注意事项

- ※1. 只有CVLKW-065法兰的倾角为12°。
- ※2. 本产品未附安装螺栓，请用户参考S尺寸并根据安装高度自行配备。
- ※3. 本产品未附带调速控制阀。
- ※4. 排气孔必须进行大气开放，且务必防止冷却液、切削液的侵入，冷却液会直接飞溅，请在M3螺纹上设置垫块，有效防止冷却液的侵入，且务必保证排气孔不被堵塞。压板安装用销钉请使用附带的销钉（∅Adf6, ∅Aef6, HRC60的相关产品）
- ※5. 请参考S尺寸，并根据安装高度决定安装螺栓的EA螺纹孔的深度。

## 夹紧·释放型安装部位加工尺寸

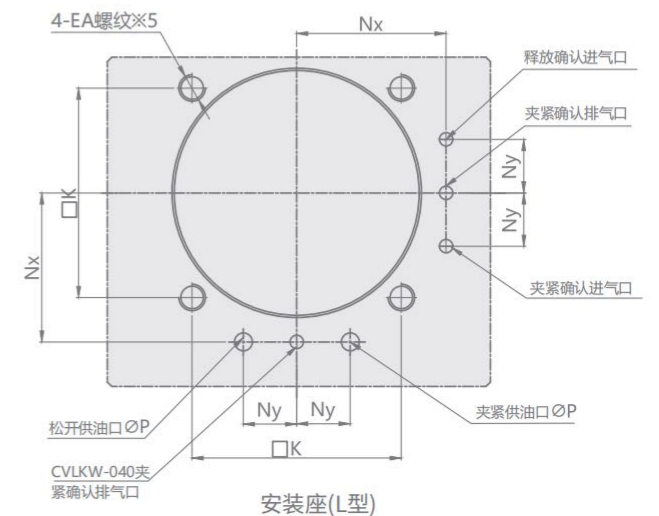
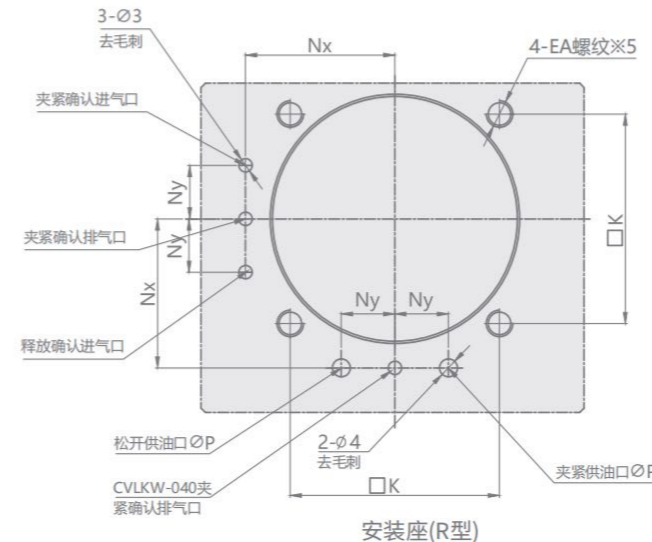
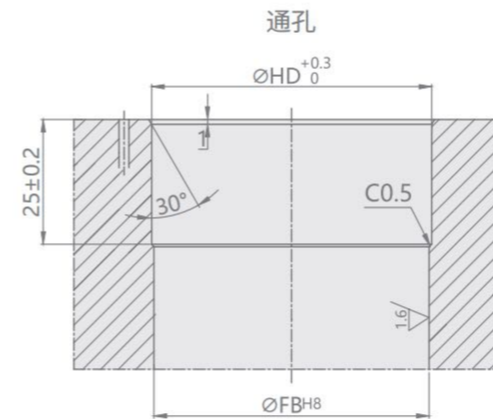
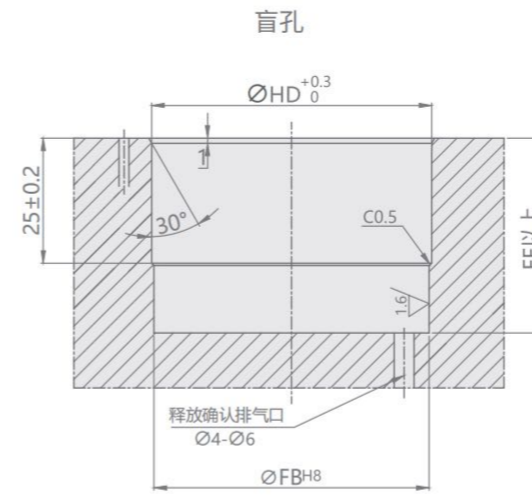

## 外形尺寸表

Unit:mm

型号 Model	CVLKW-040CE	CVLKW-048CE	CVLKW-055CE	CVLKW-065CE	CVLKW-075CE
全行程	20.5	23.5	26	29.5	35
夹紧行程	17.5	20.5	23	26.5	32
行程余量	3	3	3	3	3
HA	92.5	103.5	110.5	124.5	145.5
HB	54	61	69	81	94.5
HC	54	61	69	81	94.5
HD	40	48	55	65	75
HE	59	64.5	65	70.5	78.5
HF	34	36.5	37	40.5	41.5
G	25	28	28	30	37
H	31.5	35.5	39	46	52
J	22.5	25.5	30	35	42.5
K	34	40	47	55	63
M	11	12	12	13	16
Nx	26	30	33.5	39.5	45
Ny	9	11	12	15	16
P	3	3	3	5	5
Q	9	9	11	11	14
R	5.5	5.5	6.8	6.8	9
S	15	16	13.5	16	17.5
T	30.5	35	37.5	45	55
U	12	14	16	20	22
V	25	29	31.5	37	45
W	30.5	34.5	35.5	39	48
X	22	26	30	35.5	43.5
Y	13	13	16	19	25
Z	21	24	28	37	40
倒角1	C3	C3	C3	C4	C10
AA	16	18.5	21	24.5	30
AC	50.2	61.2	71.7	78.7	90.8
AD	6	6	6	8	10
AE	6	6	8	10	12
AG	20.2	18.9	19.9	20.5	21.4
BA	31.6	38	43	54	64
BB	0°	0°	0°	0°	30°
BC	R10.5	R10.5	R10.5	-	-
BD	30°	30°	30°	30°	22.5°
BE	-	-	-	5	5
EA	M5x0.8	M5x0.8	M6	M6	M8
FF	34.5	37	37.5	41	42
FB <sup>H8</sup>	40 <sup>+0.04</sup>	48 <sup>+0.04</sup>	55 <sup>+0.04</sup>	65 <sup>+0.046</sup>	75 <sup>+0.046</sup>
JA	4	4	4	4	4
JB	14	14	14	19	19
夹紧用供油口: G螺纹 松开用供油口: G螺纹	G1/8	G1/8	G1/8	G1/4	G1/4
O型密封圈DA	1BP5	1BP5	1BP5	1BP7	1BP7
O型密封圈DB	S568-007(90°)	1BP5	1BP5	1BP5	1BP5

## 外形尺寸图 External Dimensions

• 本图表示CVLKW-CE的夹紧状态

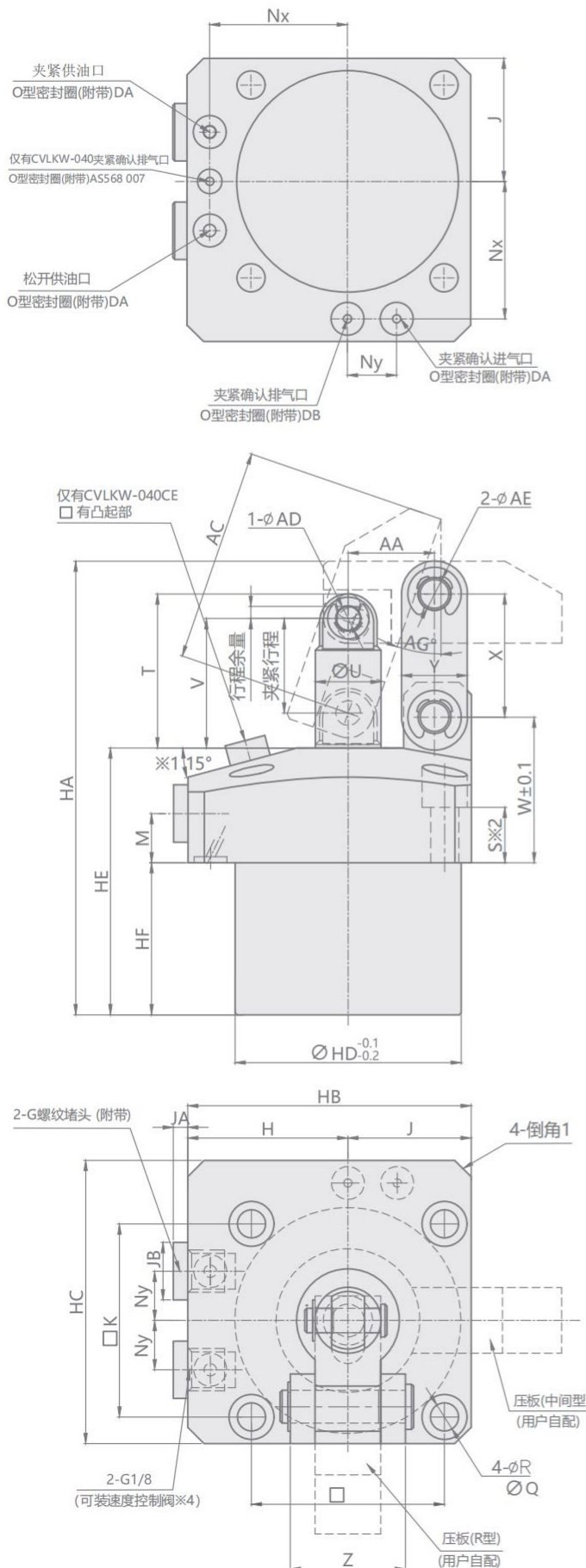

### 夹紧动作确认型

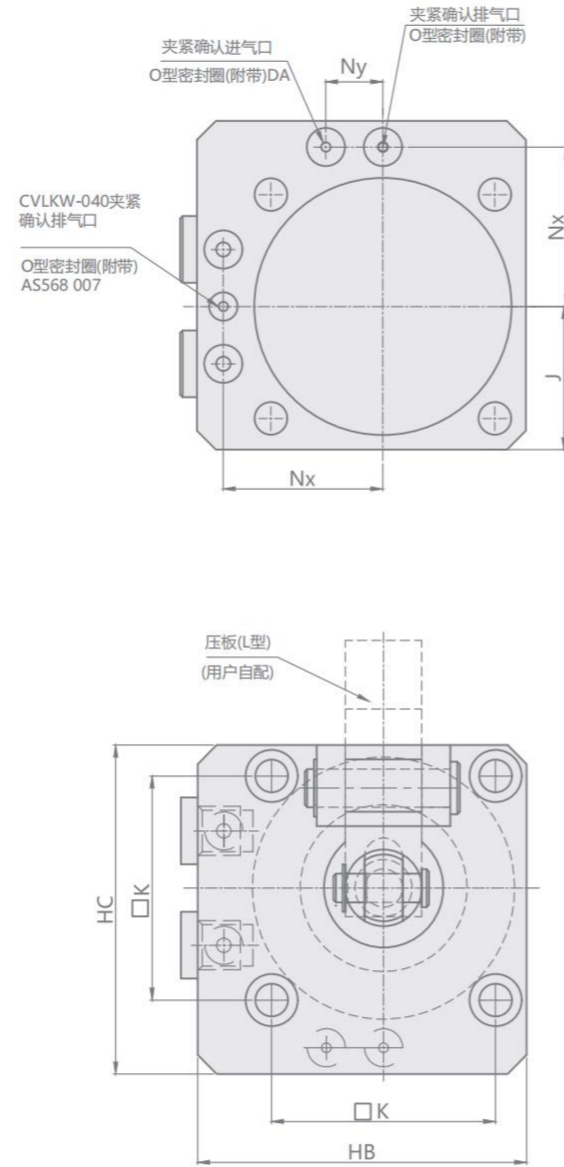

### 注意事项

- ※1. 只有CVLKW-065法兰的倾角为12°。
- ※2. 本产品未附安装螺栓，请用户参考S尺寸并根据安装高度自行配备。
- ※3. 本产品未附带调速控制阀。
- ※4. 排气孔必须进行大气开放，且务必防止冷却液、切削液的侵入，冷却液会直接飞溅，请在M3螺纹上设置垫块，有效防止冷却液的侵入，且务必保证排气孔不被堵塞。压板安装用销钉请使用附带的销钉（ $\phi ADf6, \phi AEF6, HRC60$ 的相关产品）
- ※5. 请参考S尺寸，并根据安装高度决定安装螺栓的EA螺纹孔的深度。

## 夹紧安装部位加工尺寸

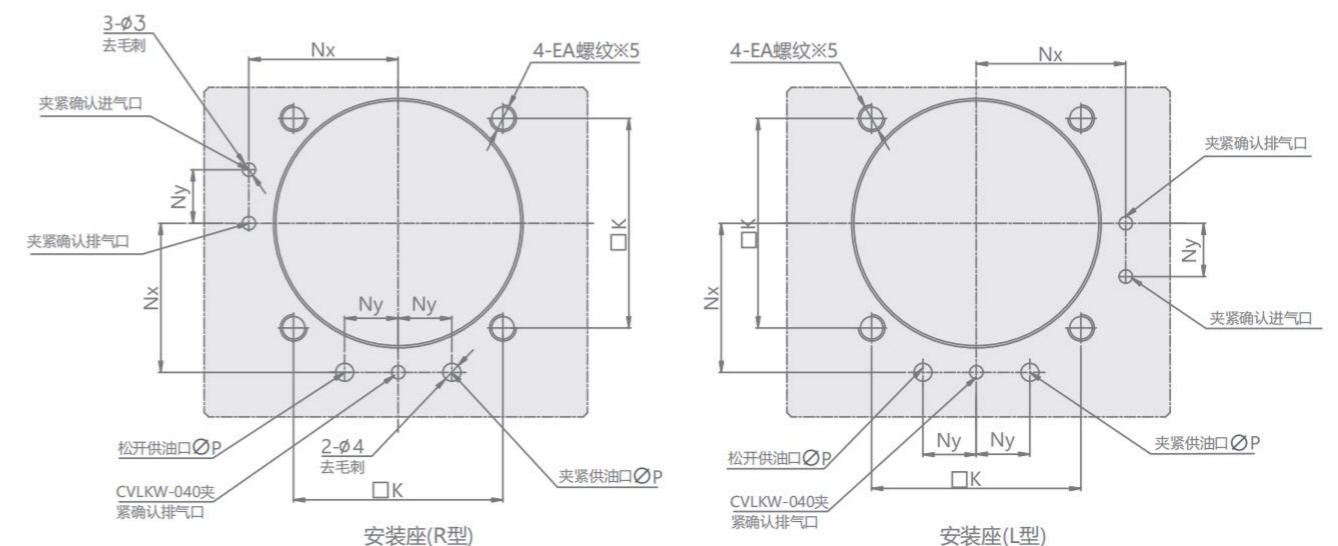
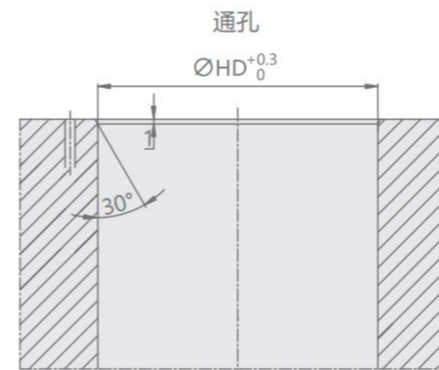
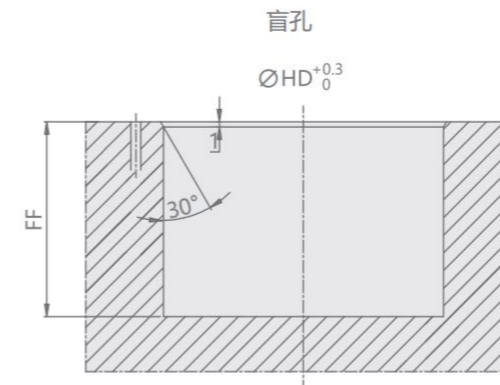

## 外形尺寸表

Unit:mm

型号 Model	CVLKW-040CH	CVLKW-048CH	CVLKW-055CH	CVLKW-065CH	CVLKW-075CH
全行程	20.5	23.5	26	29.5	35
夹紧行程	17.5	20.5	23	26.5	32
行程余量	3	3	3	3	3
HA	88.5	99.5	109	124.5	145.5
HB	54	61	69	81	94.5
HC	54	61	69	81	94.5
HD	40	48	55	65	75
HE	55	60.5	63.5	70.5	78.5
HF	30	32.5	35.5	40.5	41.5
G	25	28	28	30	37
H	31.5	35.5	39	46	52
J	22.5	25.5	30	35	42.5
K	34	40	47	55	63
M	11	12	12	13	16
Nx	26	30	33.5	39.5	45
Ny	9	11	12	15	16
P	3	3	3	5	5
Q	9	9	11	11	14
R	5.5	5.5	6.8	6.8	9
S	15	16	13.5	16	17.5
T	30.5	35	37.5	45	55
U	12	14	16	20	22
V	25	29	31.5	37	45
W	30.5	34.5	35.5	39	48
X	22	26	30	35.5	43.5
Y	13	13	16	19	25
Z	21	24	28	37	40
倒角1	C3	C3	C3	C4	C10
AA	16	18.5	21	24.5	30
AC	50.2	61.2	71.7	78.7	90.8
AD	6	6	6	8	10
AE	6	6	8	10	12
AG	20.2	18.9	19.9	20.5	21.4
EA	M5x0.8	M5x0.8	M6	M6	M8
FF	30.5	33	36	41	42
FB <sup>H</sup>	40 <sup>+0.04</sup> <sub>0</sub>	48 <sup>+0.04</sup> <sub>0</sub>	55 <sup>+0.04</sup> <sub>0</sub>	65 <sup>+0.046</sup> <sub>0</sub>	75 <sup>+0.046</sup> <sub>0</sub>
JA	4	4	4	4	4
JB	14	14	14	19	19
夹紧用供油口: G螺纹 松开用供油口: G螺纹	G1/8	G1/8	G1/8	G1/4	G1/4
O型密封圈DA	1BP5	1BP5	1BP5	1BP7	1BP7
O型密封圈DB	S568-007(90°)	1BP5	1BP5	1BP5	1BP5

## 外形尺寸图 External Dimensions

• 本图表示CVLKW-CE的夹紧状态

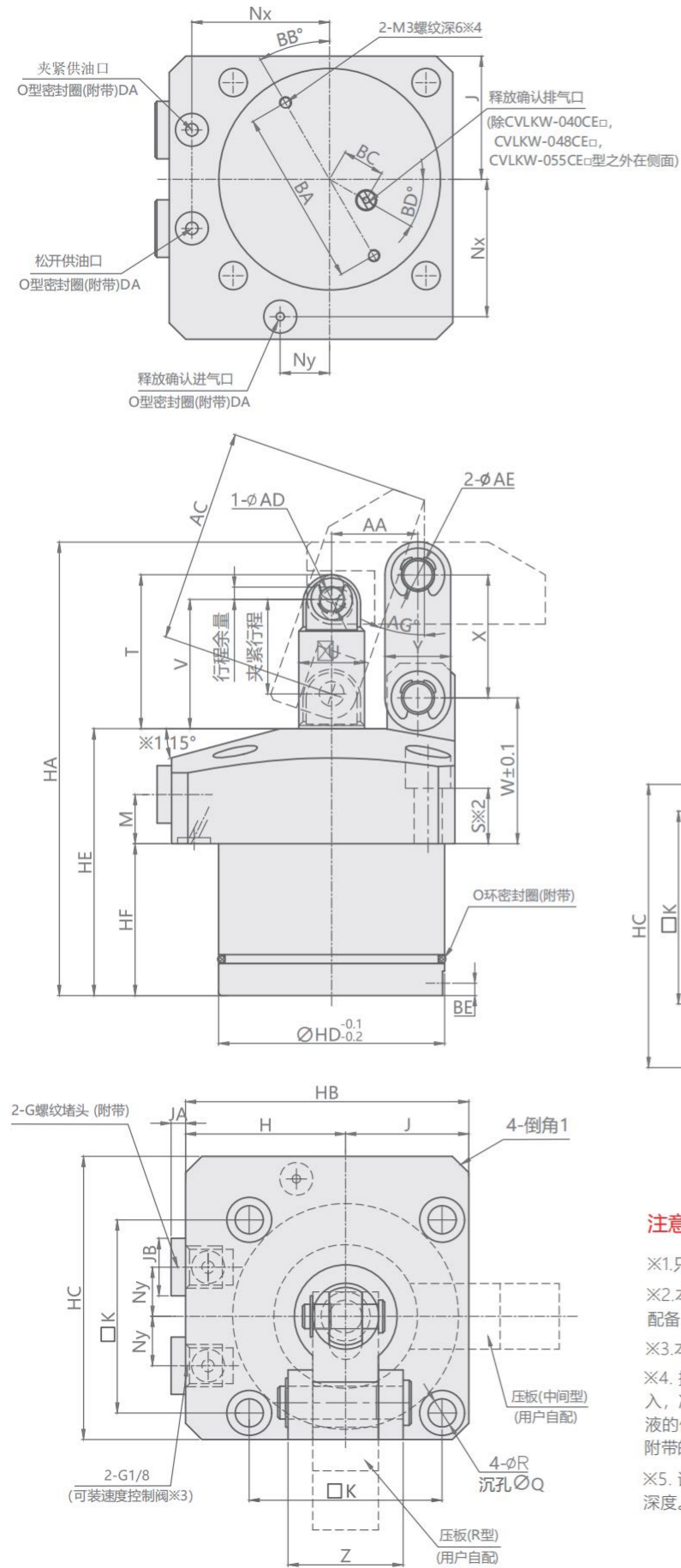

### 释放动作确认型

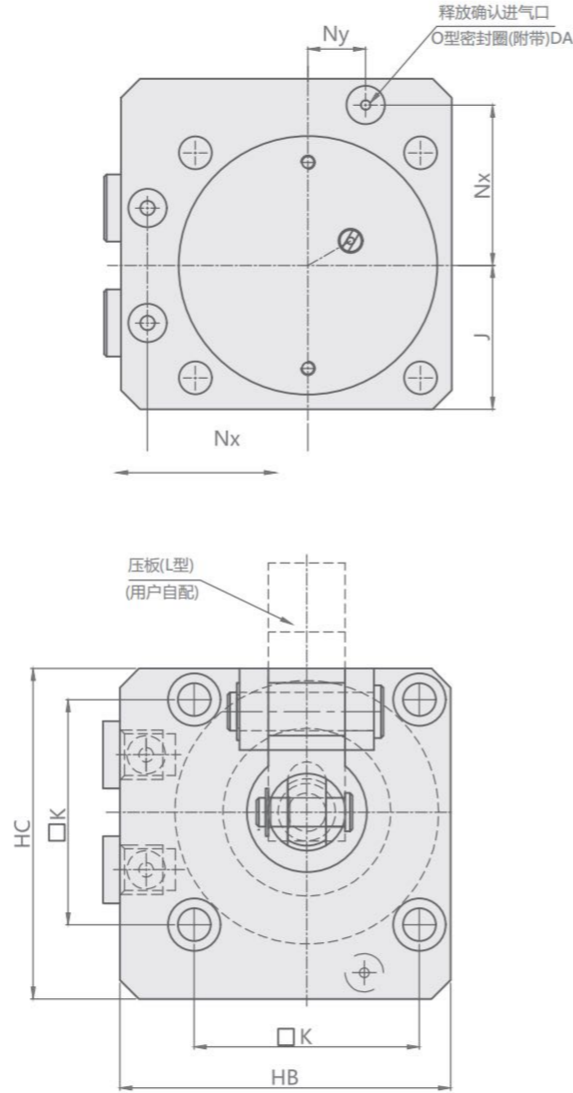

### 注意事项

- ※1. 只有CVLKW-065法兰的倾角度为12°。
- ※2. 本产品未附安装螺栓，请用户参考S尺寸并根据安装高度自行配备。
- ※3. 本产品未附带调速控制阀。
- ※4. 排气孔必须进行大气开放，且务必防止冷却液、切削液的侵入，冷却液会直接飞溅，请在M3螺纹上设置垫块，有效防止冷却液的侵入，且务必保证排气孔不被堵塞。压板安装用销钉请使用附带的销钉（ $\phi ADf6$ ,  $\phi AEF6$ , HRC60的相关产品）
- ※5. 请参考S尺寸，并根据安装高度决定安装螺栓的EA螺纹孔的深度。

### 释放动作安装部位加工尺寸

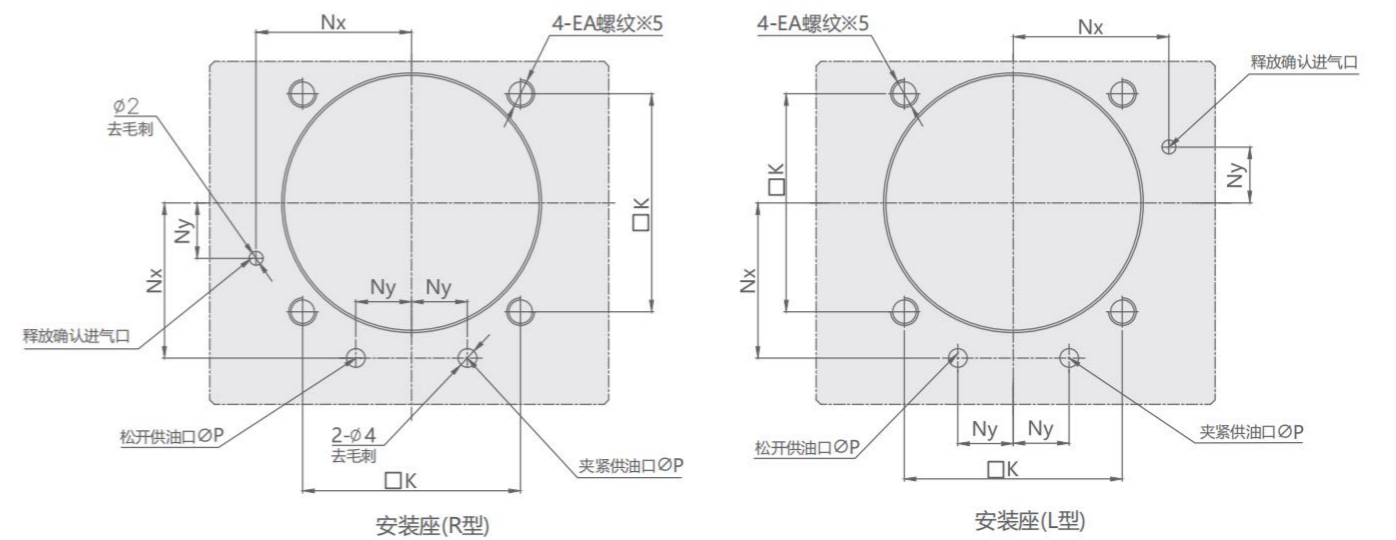
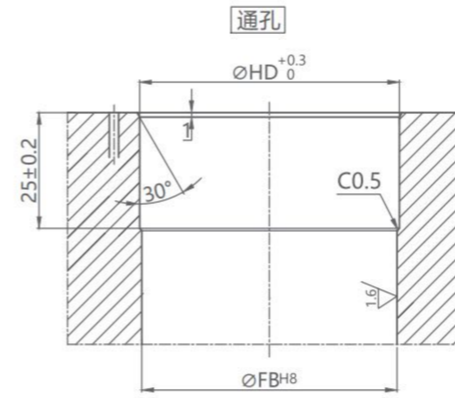
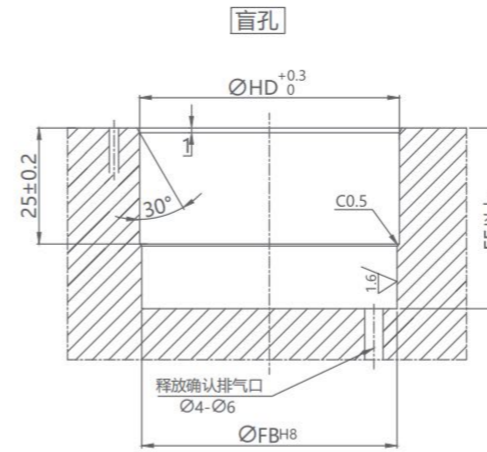

## 外形尺寸表

Unit:mm

型号 Model	CVLKW-040CJ	CVLKW-048CJ	CVLKW-055CJ	CVLKW-065CJ	CVLKW-075CJ
全行程	20.5	23.5	26	29.5	35
夹紧行程	17.5	20.5	23	26.5	32
行程余量	3	3	3	3	3
HA	84.5	95	104	121.5	144.5
HB	54	61	69	81	94.5
HC	54	61	69	81	94.5
HD	40	48	55	65	75
HE	59	64.5	65	70.5	78.5
HF	34	36.5	37	40.5	41.5
G	25	28	28	30	37
H	31.5	35.5	39	46	52
J	22.5	25.5	30	35	42.5
K	34	40	47	55	63
M	11	12	12	13	16
NX	26	30	33.5	39.5	45
NY	9	11	12	15	16
P	3	3	3	5	5
Q	9	9	11	11	14
R	5.5	5.5	6.8	6.8	9
S	15	16	13.5	16	17.5
T	30.5	35	37.5	45	55
V	12	14	16	20	22
U	25	29	31.5	37	45
W	30.5	34.5	35.5	39	48
X	22	26	30	35.5	43.5
Y	13	13	16	19	25
Z	21	24	28	37	40
倒角1	C3	C3	C3	C4	C10
AA	16	18.5	21	24.5	30
AC	50.2	61.2	71.7	78.7	90.8
AD	6	6	6	8	10
AE	6	6	8	10	12
AG	20.2	18.9	19.9	20.5	21.4
BA	31.6	38	43	54	64
BB	0°	0°	0°	0°	30°
BC	R10.5	R10.5	R10.5	-	-
BD	30°	30°	30°	30°	22.5°
BE	-	-	-	5	5
EA	M5x0.8	M5x0.8	M6	M6	M8
FF	34.5	37	37.5	41	42
FB <sup>H8</sup>	40 <sup>+0.04</sup> <sub>0</sub>	48 <sup>+0.04</sup> <sub>0</sub>	55 <sup>+0.04</sup> <sub>0</sub>	65 <sup>+0.046</sup> <sub>0</sub>	75 <sup>+0.046</sup> <sub>0</sub>
JA	4	4	4	4	4
J8	14	14	14	19	19
夹紧用供油口: G螺纹 松开用供油口: G螺纹	G1/8	G1/8	G1/8	G1/4	G1/4
O型密封圈DA	1BP5	1BP5	1BP5	1BP7	1BP7

# CLKW

## 传感器内置式杠杆缸

## CLKW AIR SENSING LEVERAGE CLAMP



### 产品特性

此系列产品动作端内置有动作确认机构，最适用于实现设备的自动化。通过连接空气传感器，检出压差，实现确认动作。通过夹紧动作确认，能实现安全可靠地将工件搬入搬出。内置传感阀，可实现超薄型的夹具设计。简单的油路孔设计。

最大操作压力: 70 kgf/cm<sup>2</sup>  
最小操作压力: 5 kgf/cm<sup>2</sup>

### FEATURES

The CLKW series utilizes air sensing mechanisms by detecting the differential pressure to achieve action confirmation, allowing safe and efficient loading/unloading of the workpiece. With the integration of the built-in sensor valves, the CLKW series has taken a new and improved compact design and is most suitable for achieving automation.

Max. operating pressure: 70 kgf/cm<sup>2</sup>  
Min. operating pressure: 5 kgf/cm<sup>2</sup>

### 注意事项

夹紧及放松动作速度需适当放缓。为进行确认动作，须设置空气传感器。气口须进行大气开放，务必防止冷却液、切削渣的侵入。使用时请保持向气口常态供气状态。

### NOTE

The speed of clamping and unclamping action needs to be slowed down appropriately. Action confirmation can be conducted by detecting differential pressure with the air sensor. Please keep clearance of the air exhaust hole to prevent the intrusion of coolant and chips. Make sure to supply constant air pressure to the air port when in use.

### 订购标示法 ORDERING INDICATION

#### 示例: CLKW-048CRE

CLKW	系列 Series	CLKW
048	主体尺寸 Body size	040: ΦD=40mm    065: ΦD=65mm    ΦD表示本体油缸外径尺寸 048: ΦD=48mm    075: ΦD=75mm    Outer diameter ΦD of the cylinder 055: ΦD=55mm
C	板式连接型(附带G螺纹堵头) Gasket Option(With G Thread Plug)	附带G螺纹堵头可安装速度控制阀(CZL)(用户另行购买) With G Thread Plug(able to attach Speed Control Valve) (Order the valve separately Recommended:CZL)
R	压臂安装方向 Lever direction	L: 左    L: Left 空白: 中央    Blank: Center R: 右    R: Right
E	传感阀符号 Sensing Valve	E: 夹紧-释放动作确认型    E: Clamp-Unclamp Confirmation (Both) H: 夹紧动作确认型    H: Clamp Confirmation Only J: 释放动作确认型    J: Unclainp Confirmation Only

注:推荐使用气缸0.1-0.2MPa, 空气感测器为SMC的ISA2-HE45N  
Note: Recommended Operating Air Pressure 0.1~0.2MPa. Air Sensor: ISA2-HE45N(SMC)

### 传感器内置式杠杆缸 Air Sensing LEVERAGE Clamp

#### 动作原理(剖面结构)

※ 本图表示夹紧-释放动作确认型(Model CLKW-COE)

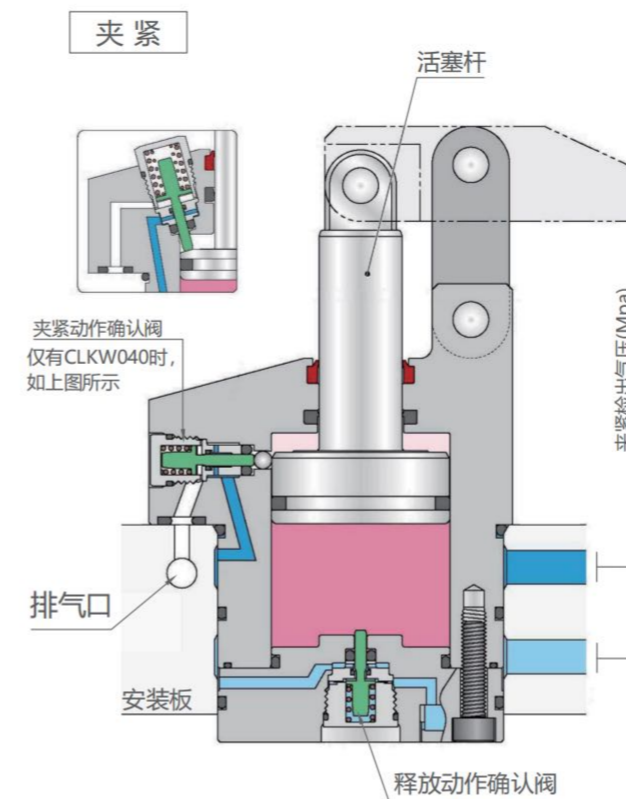

夹紧(向夹紧用供油口供给油压时) 活塞杆上升, 夹紧工件。

※ 仅有CLKW040在此状态下解除夹紧侧的油压供给时, 活塞杆有可能在内置弹簧的作用下发生微动。

油压		空气传感器	
夹紧油压	释放油压	夹紧动作确认	释放动作确认
ON	OFF	ON	OFF

#### 夹紧动作确认 空气传感流程图

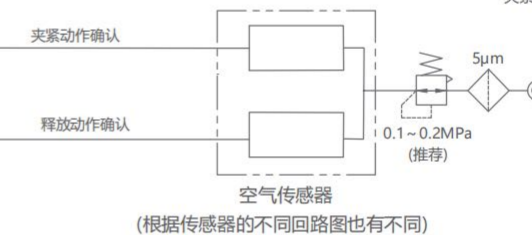
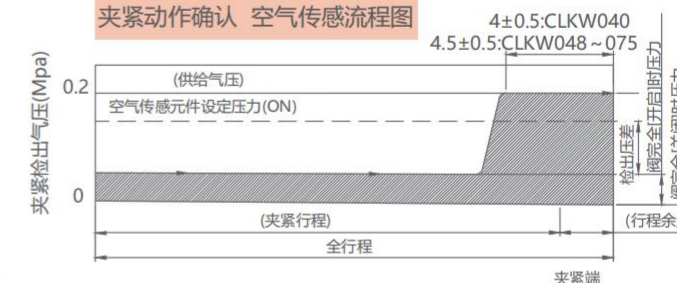

释放(向释放用供油口供给油压时) 活塞杆下降。

※ 在此状态下解除释放侧的油压供给时, 活塞杆有可能在内置弹簧的作用下发生微动。

油压		空气传感器	
夹紧油压	释放油压	夹紧动作确认	释放动作确认
OFF	ON	OFF	ON

#### 释放动作确认 空气传感流程图

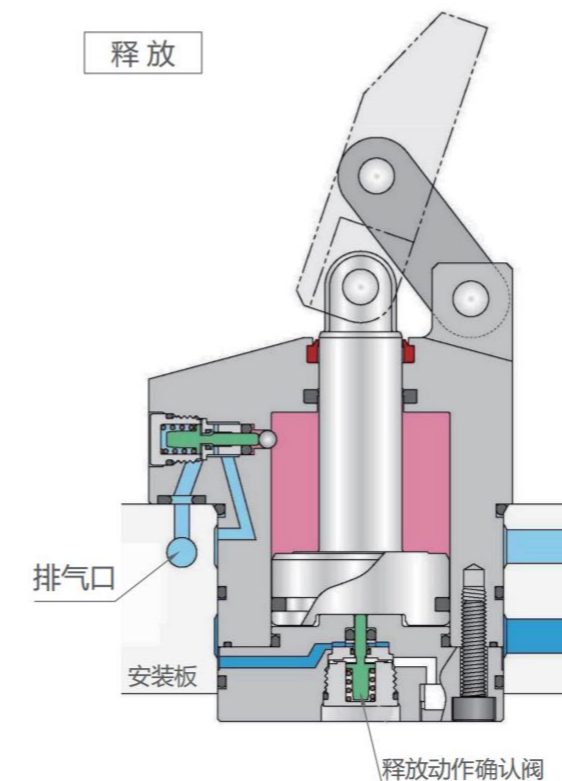
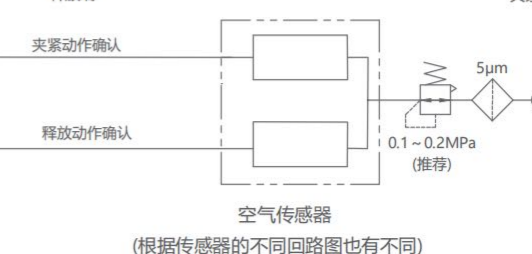
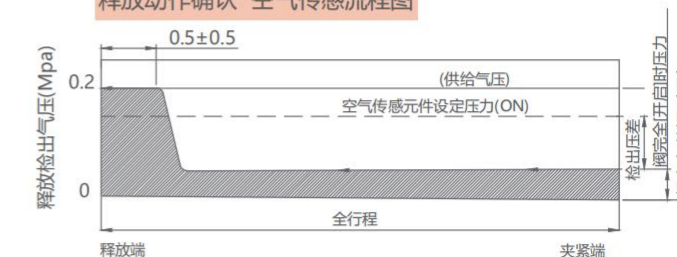

## 夹紧·释放动作确认型 CLAMP-UNCLAMP CONFIRMATION

※本图表示CLKW-CE的夹紧状态  
The drawing shows the Clamped state of CLKW-CE

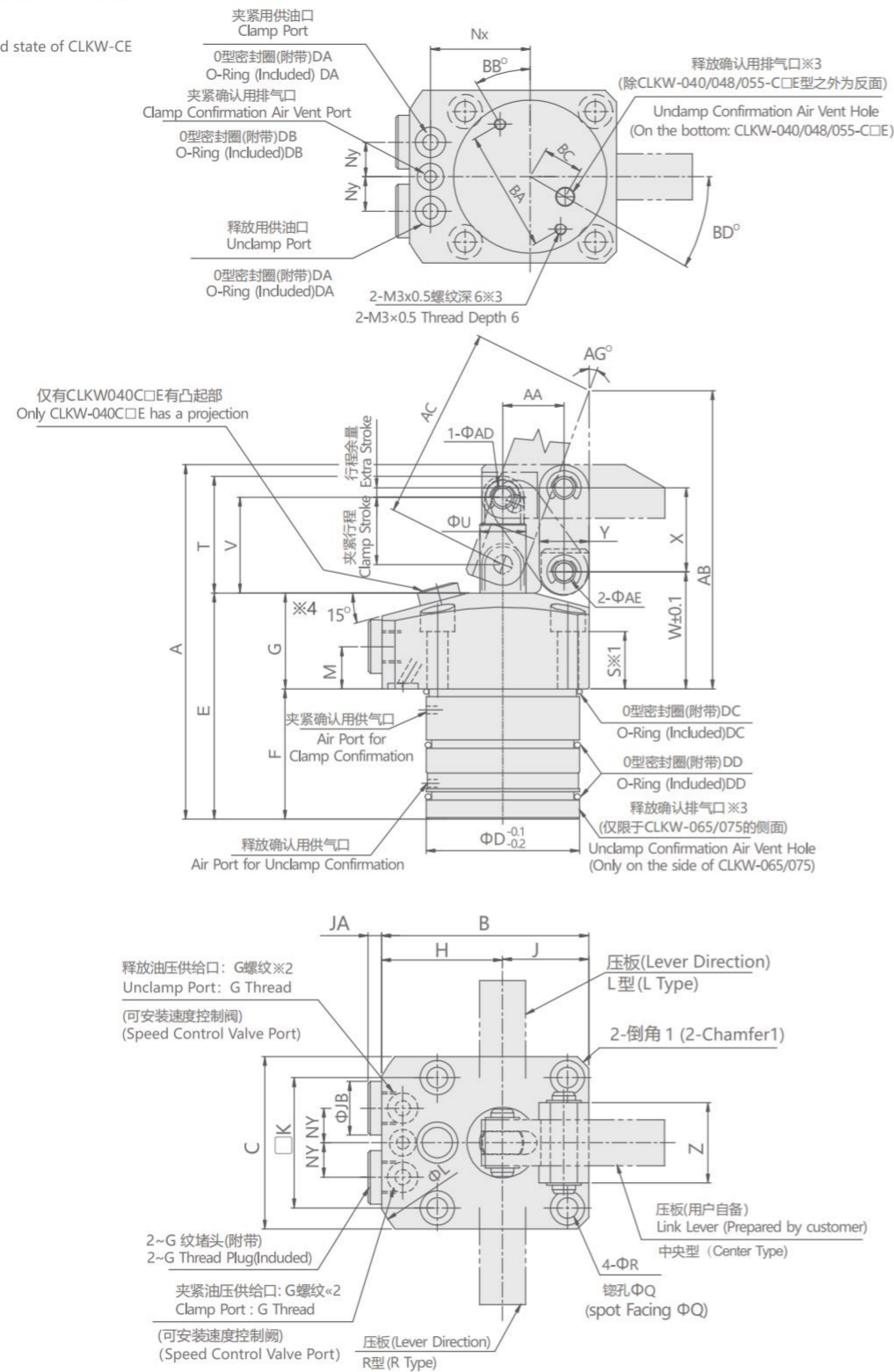

### 注意事项

- ※1. 本产品未附带安装螺栓。请用户参考S尺寸并根据安装高度自行配备。
- ※2. 本产品未附带速度控制阀。请用户自行配备。
- ※3. 排气孔必须进行大气开放，且务必防止冷却液-切削物的侵入。冷却液会直接飞溅时，请在M3螺纹上设置垫块儿，有效防止冷却液的侵入。且务必保证排气孔不被堵塞。
- ※4. 只有CLKW-065法兰的倾斜角度为12°。

### NOTE

- ※1. This product does not come with mounting bolts. Please prepare them according to the mounting height, refer to dimension "S".
- ※2. Speed control valve is sold separately.
- ※3. Please keep the air vent hole clear and open to prevent the intrusion of coolant and chips. If exposed to coolant, place a blocker on the M3 thread to prevent coolant and chips from entering. Please ensure the air vent hole is not blocked.
- ※4. Flange inclination angle is 12° only for CLKW-065.

## 安装部位加工尺寸 MACHINING DIMENSIONS OF MOUNTING AREA

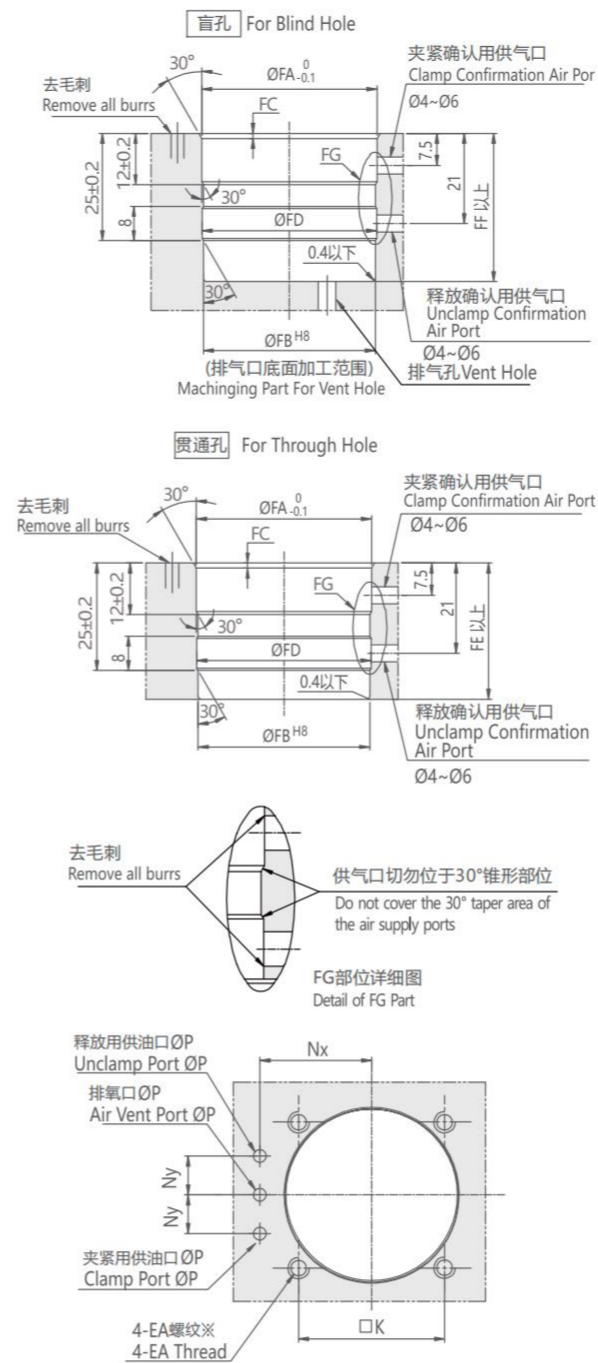

### 注意事项

※请参考S尺寸并根据安装高度决定安装螺栓的EA螺纹孔的深度。

### 规格参数表 SPECIFICATIONS

型号	理论夹持力 (70 kgf/cm <sup>2</sup> )	夹紧行程	总行程	推出容积	拉入容积	推出受压面积	拉入受压面积	使用温度范围	使用流体
MODEL	CLAMPING FORCE AT 70 kgf/cm <sup>2</sup> (kgf)	CLAMPING STROKE (mm)	TOTAL STROKE(mm)	CYLINDER CAPACITY CLAMP(cm <sup>3</sup> )	CYLINDER CAPACITY UNCLAMP(cm <sup>3</sup> )	EFF.PISTON AREA CLAMP(cm <sup>2</sup> )	EFF.PISTON AREA UNCLAMP(cm <sup>2</sup> )	RANGE OF TEMPERATURE(°C)	USABLE FLUID
CLKW-040	290	17.5	20.5	10.9	8.6	5.31	4.17	0~+70°C	相当于ISO黏度等级的ISO-VG-32 一般液压油 Recommended: ISO-VG-32 hydraulic oil equivalent to ISO viscosity grade
CLKW-048	389	20.5	23.5	16.6	13	7.07	5.52	0~+70°C	
CLKW-055	487	23	26	25.0	19.8	9.62	7.62	0~+70°C	
CLKW-065	852	26.5	29.5	46.9	37.7	15.9	11.76	0~+70°C	
CLKW-075	1332	32	35	83.2	69.8	23.8	20	0~+70°C	

Unit:mm

MODEL ITEM	CLKW-040C□E	CLKW-048C□E	CLKW-055C□E	CLKW-065C□E	CLKW-075C□E
A	92.5	103.5	110.5	124.5	145.5
B	54	61	69	81	94.5
C	45	51	60	70	85
D	40	48	55	65	75
E	59	64.5	65	70.5	78.5
F	34	36.5	37	40.5	41.5
G	25	28	28	30	37
H	31.5	35.5	39	46	52
J	22.5	25.5	30	35	42.5
K	34	40	47	55	63
L	72	81	88	106	116
M	11	12	12	13	16
Nx	26	30	33.5	39.5	45
Ny	9	11	12	15	16
P	3	3	3	5	5
Q	9	9	11	11	14
R	5.5	5.5	6.8	6.8	9
S	15	16	13.5	16	17.5
T	30.5	35	37.5	45	55
U	12	14	16	20	22
V	25	29	31.5	37	45
W	30.5	34.5	35.5	39	48
X	22	26	30	35.5	43.5
Y	13	13	16	19	25
Z	21	24	28	37	40
倒角1	C3	C3	C3	C4	C10
AA	16	18.5	21	24.5	30
AB	77.7	92.4	101.9	111.4	130.8
AC	50.2	61.2	71.7	78.7	90.8
AD	6	6	6	8	10
AE	6	6	8	10	12
AG	20.2	18.9	19.9	20.5	21.4
BA	31.6	38	43	54	64
BB	0°	0°	0°	0°	30°
BC	R10.5	R10.5	R10.5	-	-
BD	30°	30°	30°	30°	22.5°
EA	M5X0.8	M5X0.8	M6	M6	M8
FA	40.8	49	56	66	76
FB	40 <sup>+0.04</sup> <sub>0</sub>	48 <sup>+0.04</sup> <sub>0</sub>	55 <sup>+0.04</sup> <sub>0</sub>	65 <sup>+0.046</sup> <sub>0</sub>	75 <sup>+0.046</sup> <sub>0</sub>
FC	1.2	1.2	1.5	1.5	1.5
FD	40.6	48.6	55.6	65.6	75.6
FE	30	32	30	30	30
FF	34.5	37	37.5	41	42
JA	4	4	4	4.5	4.5
JB	14	14	14	19	19
夹紧用供油口:G螺纹 Clamp Port:G Thread	G1/8	G1/8	G1/8	G1/4	G1/4
释放用供油口:G螺纹 Unclamp Port:G Thread	G1/8	G1/8	G1/8	G1/4	G1/4
O型密封圈 O-Ring	DA AS568-007(90°)	DB 1BP5	DC AS568-031(70°)	DD AS568-034(70°)	AS568-037(70°) AS568-040(70°) AS568-028(70°) AS568-031(70°) AS568-033(70°) AS568-036(70°) AS568-039(70°)

### NOTE

※EA tapping depth the mounting bolt should be decided according to the mounting height referring to dimensions "S".

**夹紧动作确认型  
CLAMP CONFIRMATION ONLY**

※本图表示CLKW-CH的夹紧状态  
The drawing shows the clamped state of CLKW-CH

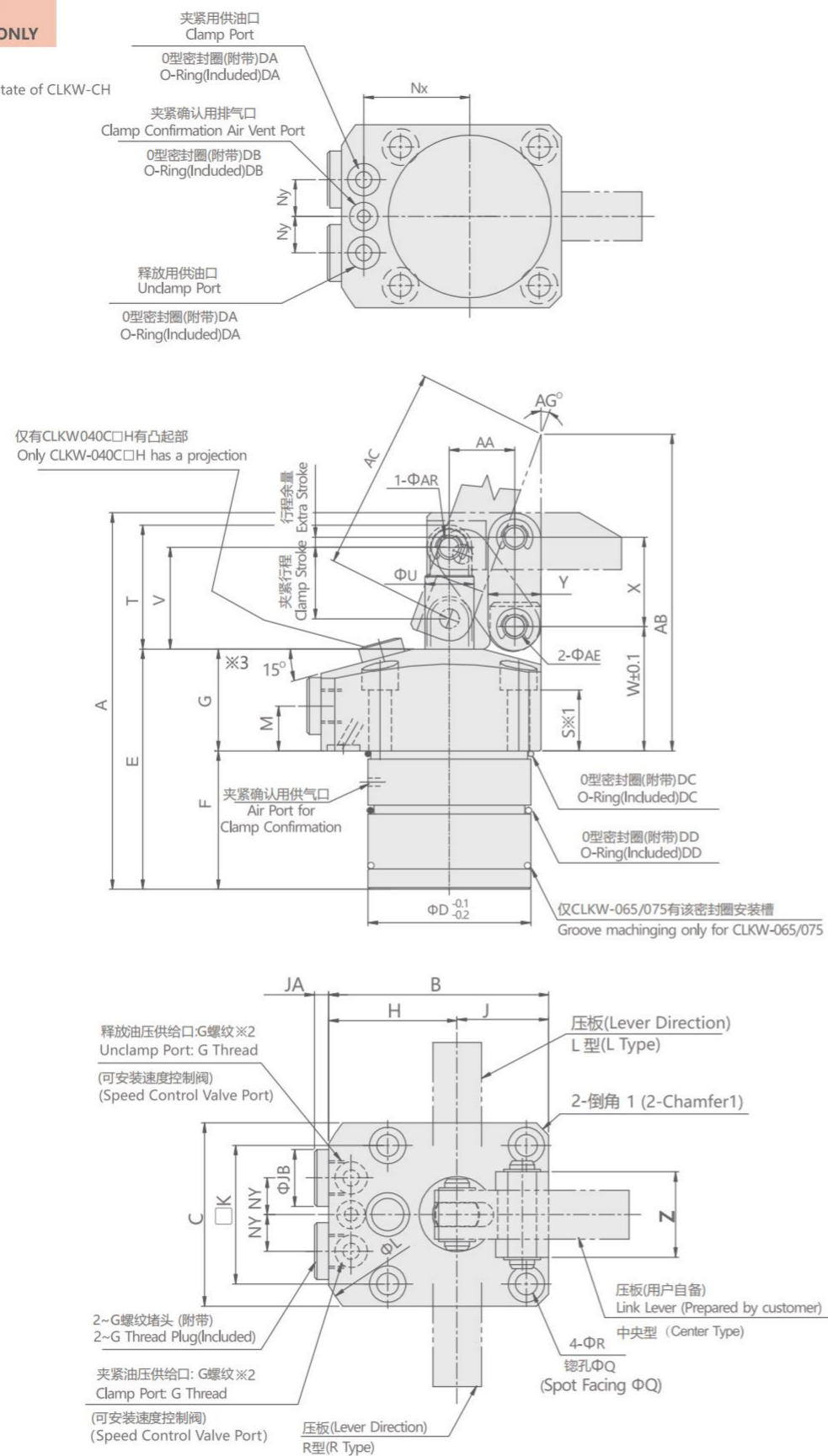

**注意事项**

- ※1. 本产品未附带安装螺栓。请用户参考S尺寸并根据安装高度自行配备。
- ※2. 本产品未附带速度控制阀。请用户自行配备。
- ※3. 只有CLKW-065法兰的倾斜角度为12°

**NOTE**

- ※1. Mounting bolts are not provided with the product. Please prepare them according to the mounting height referring to dimension "S".
- ※2. Speed control valve is sold separately.
- ※3. Flange inclination angle is 12° only for CLKW-065.

**安装部位加工尺寸  
MACHINING DIMENSIONS OF MOUNTING AREA**

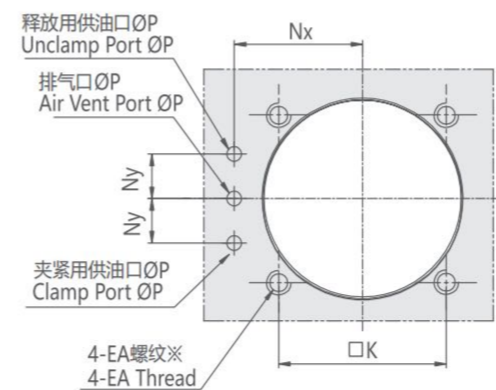
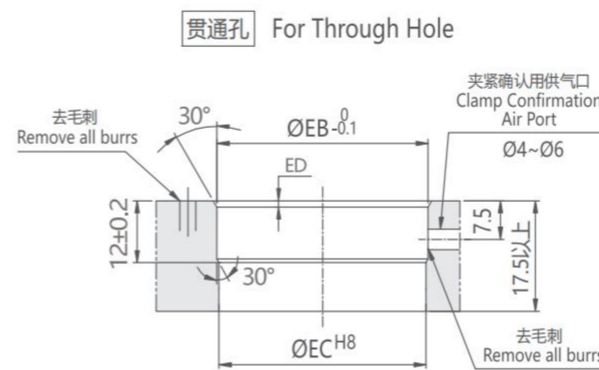
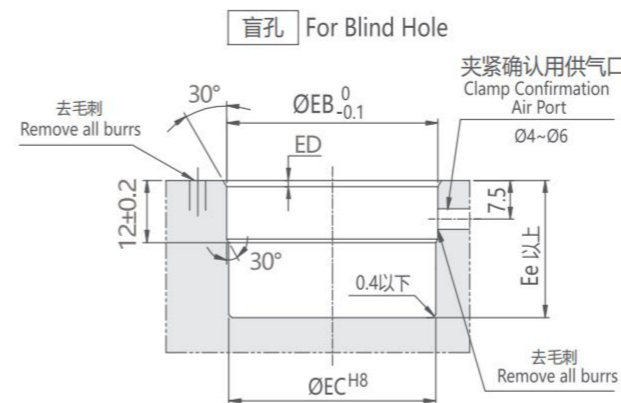

**注意事项**

※请参考S尺寸并根据安装高度决定安装螺栓的EA螺纹孔的深度。

Unit:mm

MODEL ITEM	CLKW-040C□H	CLKW-048C□H	CLKW-055C□H	CLKW-065C□H	CLKW-075C□H
A	88.5	99.5	109	124.5	145.5
B	54	61	69	81	94.5
C	45	51	60	70	85
D	40	48	55	65	75
E	55	60.5	63.5	70.5	78.5
F	30	32.5	35.5	40.5	41.5
G	25	28	28	30	37
H	31.5	35.5	39	46	52
J	22.5	25.5	30	35	42.5
K	34	40	47	55	63
L	72	81	88	106	116
M	11	12	12	13	16
Nx	26	30	33.5	39.5	45
Ny	9	11	12	15	16
P	3	3	3	5	5
Q	9	9	11	11	14
R	5.5	5.5	6.8	6.8	9
S	15	16	13.5	16	17.5
T	30.5	35	37.5	45	55
U	12	14	16	20	22
V	25	29	31.5	37	45
W	30.5	34.5	35.5	39	48
X	22	26	30	35.5	43.5
Y	13	13	16	19	25
Z	21	24	28	37	40
倒角1	C3	C3	C3	C4	C10
AA	16	18.5	21	24.5	30
AB	77.7	92.4	101.9	111.4	130.8
AC	50.2	61.2	71.7	78.7	90.8
AD	6	6	6	8	10
AE	6	6	8	10	12
AG	20.2	18.9	19.9	20.5	21.4
EA	M5X0.8	M5X0.8	M6	M6	M8
EB	40.8	49	56	66	76
EC	40 <sup>+0.04</sup> <sub>0</sub>	48 <sup>+0.04</sup> <sub>0</sub>	55 <sup>+0.04</sup> <sub>0</sub>	65 <sup>+0.04</sup> <sub>0</sub>	75 <sup>+0.04</sup> <sub>0</sub>
ED	1.2	1.2	1.5	1.5	1.5
EE	30.5	33	36	41	42
JA	4	4	4	4.5	4.5
JB	14	14	14	19	19
夹紧用供油口:G螺纹 Clamp Port:G Thread	G1/8	G1/8	G1/8	G1/4	G1/4
释放用供油口:G螺纹 Unclamp Port:G Thread					
0型密封圈 O-Ring	DA 1BP5	1BP5	1BP5	1BP7	1BP7
DB AS568-007(90°)		1BP5	1BP5	1BP7	1BP7
DC 38x1.5(内径×线径)	AS568-031(70°)	AS568-033(70°)	AS568-036(70°)	AS568-040(70°)	
DD AS568-028(70°)	AS568-031(70°)	AS568-033(70°)	AS568-036(70°)	AS568-039(70°)	

**NOTE**

※EA tapping depth the mounting bolt should be decided according to the mounting height referring to dimensions "S".

**释放动作确认型**  
UNCLAMP CONFIRMATION ONLY

※本图表示CLKW-CJ的夹紧状态  
The drawing shows the clamped state of CLKW-CJ

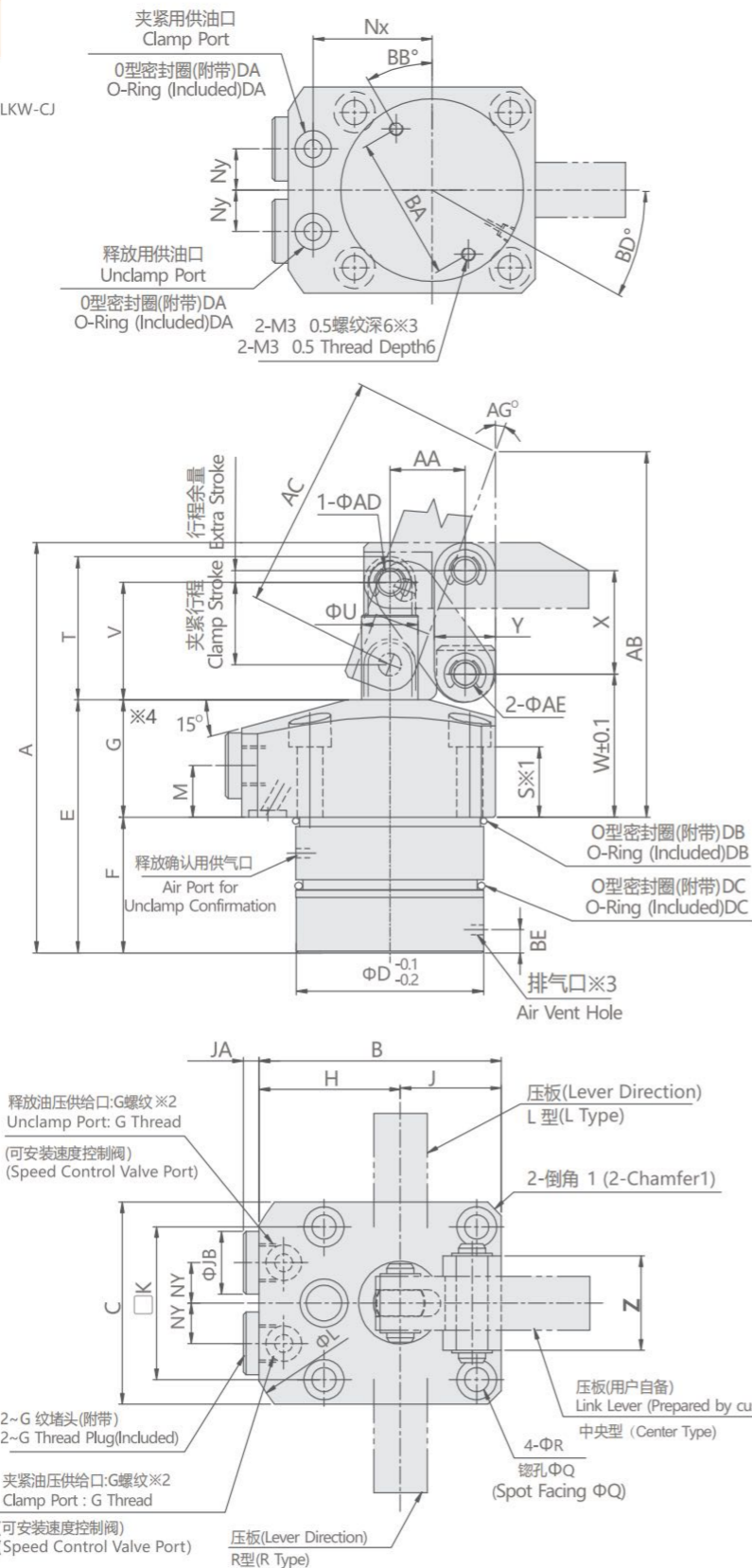

**注意事项**

- ※1. 本产品未附带安装螺栓。请用户参考S尺寸并根据安装高度自行配备。
- ※2. 本产品未附带速度控制阀。请用户自行配备。
- ※3. 排气孔必须进行大气开放，且务必防止冷却液一切削物的侵入。冷却液会直接飞溅时，请在M3\*S纹上设置垫块儿，有效防止冷却液的侵入。且务必保证排气孔不被堵塞。
- ※4. 只有CLKW-065法兰的倾斜角度为12°。

**NOTE**

- ※1. Mounting bolts are not provided with the product. Please prepare them according to the mounting height referring to dimension "S".
- ※2. Speed control valve is sold separately.
- ※3. Please keep clear condition at the air vent hole. If exposed to coolant, place a blocker on the M3 thread to prevent coolant and chips from entering. But do not block the air vent hole.
- ※4. Flange inclination angle is 12° only for CLKW-065.

**安装部位加工尺寸**  
Machining Dimensions of Mounting Area

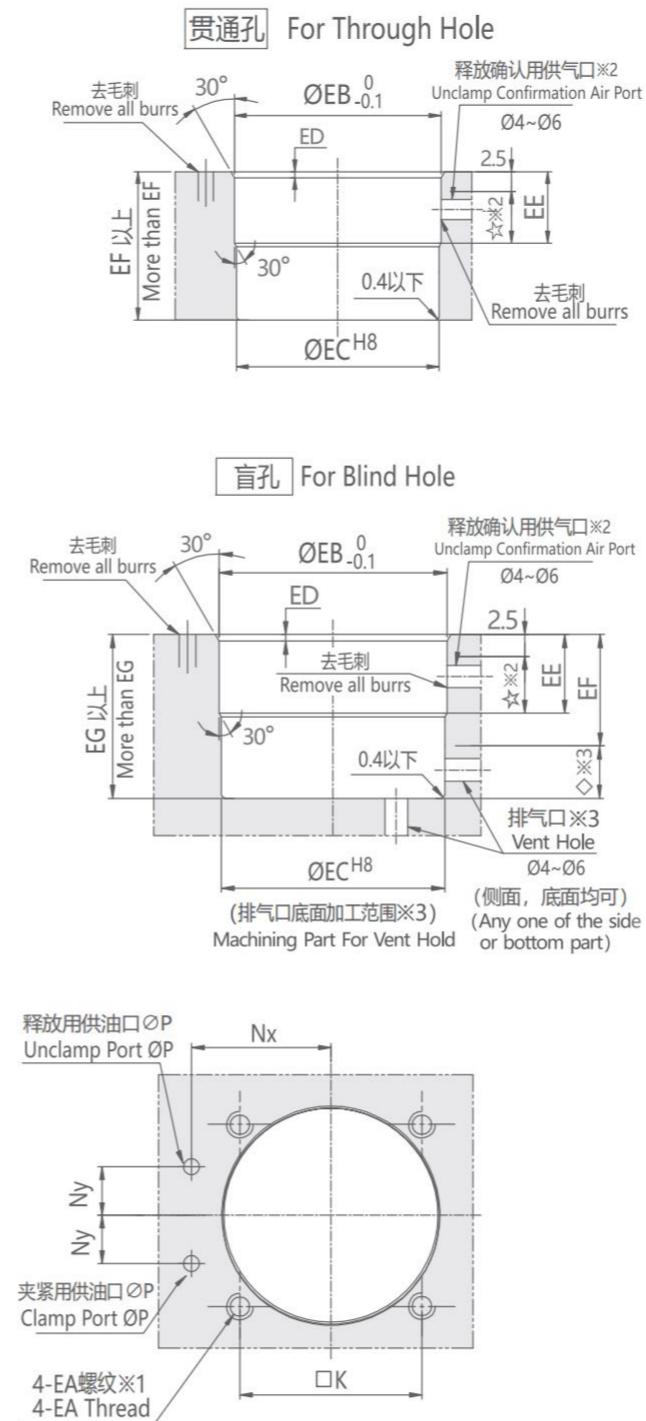

**注意事项**

- ※1. 请参考S尺寸并根据安装高度决定安装螺栓的EA螺纹孔的深度。
- ※2. 请将释放确认用供气口设置于图示☆范围内。
- ※3. 排气口可设置在侧面或底面。  
从侧面加工时，请设置在图示◇范围内。  
从底面加工时，请设置在图示ØEC范围内。

Unit:mm

MODEL ITEM	CLKW-040C□	CLKW-048C□	CLKW-055C□	CLKW-065C□	CLKW-075C□
A	84.5	95	104	121.5	144.5
B	54	61	69	81	94.5
C	45	51	60	70	85
D	40	48	55	65	75
E	51	56	58.5	67.5	77.5
F	26	28	30.5	37.5	40.5
G	25	28	28	30	37
H	31.5	35.5	39	46	52
J	22.5	25.5	30	35	42.5
K	34	40	47	55	63
L	72	81	88	106	116
M	11	12	12	13	16
Nx	26	30	33.5	39.5	45
Ny	9	11	12	15	16
P	3	3	3	5	5
Q	9	9	11	11	14
R	5.5	5.5	6.8	6.8	9
S	15	16	13.5	16	17.5
T	30.5	35	37.5	45	55
U	12	14	16	20	22
V	25	29	31.5	37	45
W	30.5	34.5	35.5	39	48
X	22	26	30	35.5	43.5
Y	13	13	16	19	25
Z	21	24	28	37	40
倒角1	C3	C3	C3	C4	C10
AA	16	18.5	21	24.5	30
AB	77.7	92.4	101.9	111.4	130.8
AC	50.2	61.2	71.7	78.7	90.8
AD	6	6	6	8	10
AE	6	6	8	10	12
AG	20.2	18.9	19.9	20.5	21.4
BA	31.6	38	43	54	64
BB	0°	0°	0°	0°	30°
BD	30°	30°	30°	30°	22.5°
BE	4.5	4.5	4.5	5	5
EA	M5X0.8	M5X0.8	M6	M6	M8
EB	40.8	49	56	66	76
EC	40 <sup>+0.04</sup> <sub>0</sub>	48 <sup>+0.04</sup> <sub>0</sub>	55 <sup>+0.04</sup> <sub>0</sub>	65 <sup>+0.04</sup> <sub>0</sub>	75 <sup>+0.04</sup> <sub>0</sub>
ED	1.2	1.2	1.5	1.5	1.5
EE	12	14	16.5	23	24.5
EF	17.5	19.5	22	28.5	30
EG	26.5	28.5	31	38	41
JA	4	4	4	4.5	4.5
JB	14	14	14	19	19
夹紧用供油口:G螺纹 Clamp Port:G Thread	G1/8	G1/8	G1/8	G1/4	G1/4
释放用供油口:G螺纹 Unclamp Port:G Thread					
O型密封圈 O-Ring	DA	1BP5	1BP5	1BP5	1BP7
DB	38x1.5 (内径x线径)	AS568-031(70°)	AS568-033(70°)	AS568-036(70°)	AS568-040(70°)
DC	AS568-028(70°)	AS568-031(70°)	AS568-033(70°)	AS568-036(70°)	AS568-039(70°)

**NOTE**

- ※1. EA tapping depth of the mounting bolt should be decided according to the mounting height referring to dimensions "S".
- ※2. Prepare the air port for unclamp confirmation within the range of ☆ mark.
- ※3. Prepare the vent hole at either side or bottom. When machining the vent hole at the side, it should be prepared within the range of ◇ mark. When machining the vent hole at the bottom, it should be prepared within the range of ØEC.

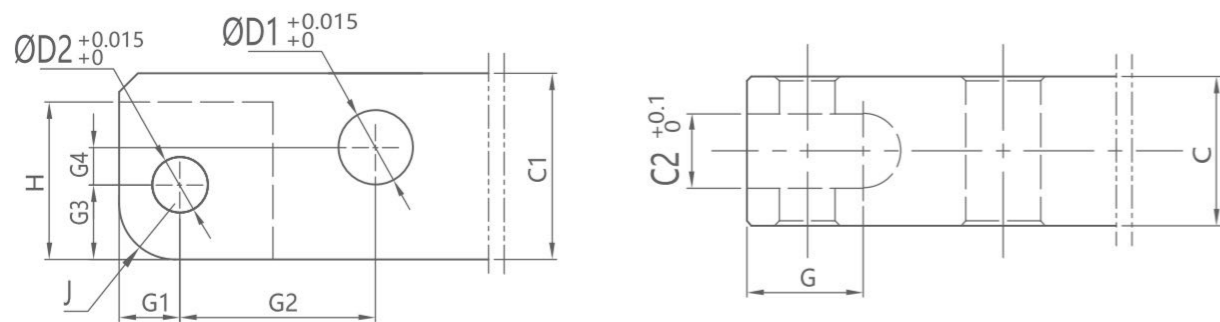

品质可嘉 百炼成刚

*Quality is commendable,  
refined into strength*

CLKW油压缸缸臂尺寸

Unit:mm

型号 MODEL	C	C1	C2	D1	D2	G	G1	G2	G3	G4	H	J
CLKW-040	12 <sup>0</sup> <sub>-0.1</sub>	14	6	6	6	11.5	5.5	16	5.5	2.5	12	R5.5
CLKW-048	12 <sup>0</sup> <sub>-0.1</sub>	16	6	6	6	13	6	18.5	6	3.5	13	R6
CLKW-055	16 <sup>0</sup> <sub>-0.1</sub>	20	8	8	6	12.5	6	21	6	6	13	R6
CLKW-065	19 <sup>0</sup> <sub>-0.1</sub>	25	10	10	8	16	8	24.5	8	7.5	17.5	R8
CLKW-075	22 <sup>0</sup> <sub>-0.1</sub>	32	11	12	10	20	10	30	10	9.5	22	R10

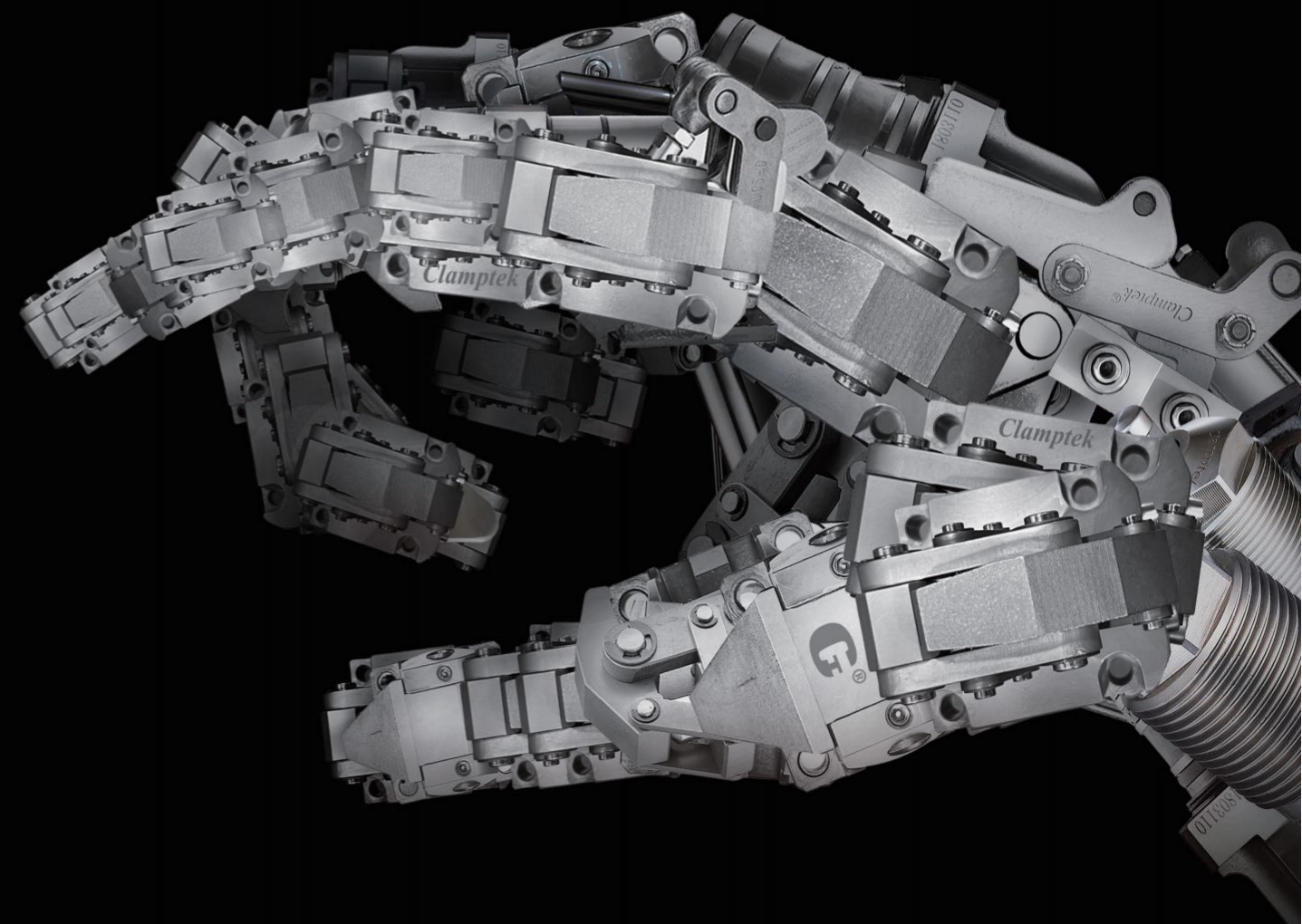

# CLKA

## 高动力&扎实型杠杆式油压缸

## CLKA HYDRAULIC LEVERAGE CLAMP



### 产品特性

此系列产品配件采用优化设计,与传统产品比较夹紧能力提高了。产品支撑点部位与缸体采用一体化结构,使体积更加扎实,提高了产品强度。产品采用了专用防尘设计,提高了防尘和密封性,实现了高密封性。产品法兰下部采用缩小设计,适合夹具要求的紧凑化和轻量化。

最大操作压力: 70 kgf/cm<sup>2</sup>  
最小操作压力: 10 kgf/cm<sup>2</sup>

### FEATURES

The accessories of the CLKA series are optimally designed and the clamping capacity has increased immensely compared to the traditional products. The cylinder and its supporting point use an integrated structure to create a more compact-sized product with enhanced strength. With its special dust-proof design, this product has improved its sealing performance and protects against any particles or debris while in use. The lower flange adopts a volume-compressed design, specifically to operate efficiently under the fixture's lightweight requirements.

Max. operating pressure: 70 kgf/cm<sup>2</sup>  
Min. operating pressure: 10 kgf/cm<sup>2</sup>

### 剖面图 Sectional view

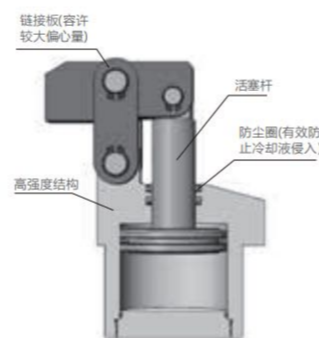

### 注意事项

夹紧及放松动作速度需适当放缓。可接受订制,欢迎与本公司洽询。

### NOTE

The action and the speed of clamping / unclamping needs to be slowed down appropriately. Customization is available upon request, please contact us for more info.

### 订购标示法 ORDERING INDICATION

#### 示例: CLKA-036CML

CLKA	系列 Series	CLKA
036	主体尺寸 Body size	036: ΦI=36 040: ΦI=40 048: ΦI=48 055: ΦI=55 065: ΦI=65 075: ΦI=75 090: ΦI=90 105: ΦI=105
C	油口型式 Port type	空白: 配管式 G: 油路板式 C: 油路板式附调速 Blank: Line type G: Manifold type C: Manifold with flow type
M	检测方式 Air detect way	无符号: 无(标准) D: 探头用双杆型 M: 适用于空气传感版式连接型 N: 适用于空气感测器配管型 No sign: No (standard) D: Double end rod option for probe M: Suitable for air sensor type connection N: Suitable for air sensor piping type
L	压臂安装方向 Lever direction	空白: 标准 L: 左 R: 右 Blank: Standard L: Left R: Right

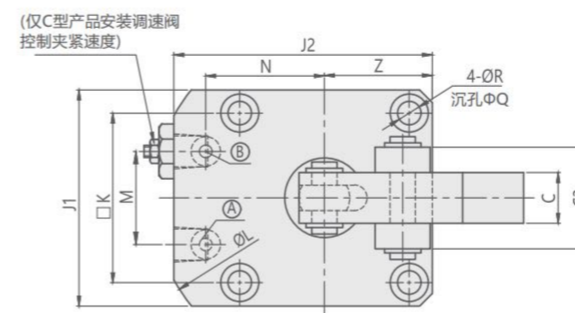
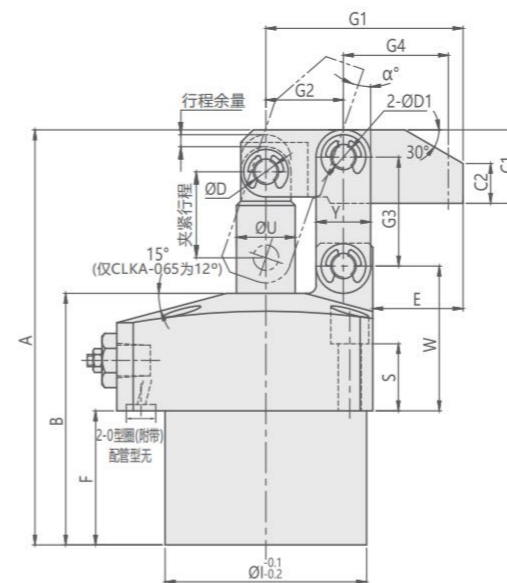

### 压臂安装方向 Lever Direction

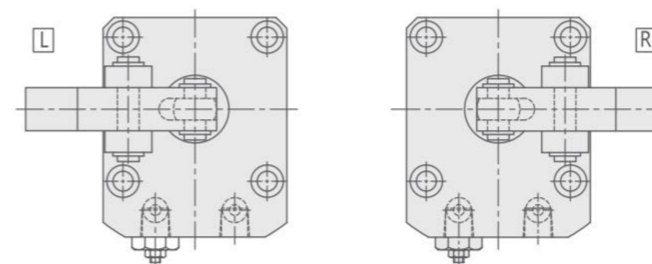

- Ⓐ 夹持油孔 Clamping port
- Ⓑ 放松油孔 Unclamping port

MODEL ITEM	CLKA -036	CLKA -040	CLKA -048	CLKA -055	CLKA -065	CLKA -075	CLKA -090	CLKA -105
A	78.5	87.5	99	110.5	127.5	151	180	209
J2	49	54	61	69	81	94.5	109.5	127
J1	40	45	51	60	70	85	100	120
I	36	40	48	55	65	75	90	105
B	48	54	60	65	73.5	84	101	115
F	23	29	32	37	43.5	47	61	65
C	10	12	12	16	19	22	25	32
Z	20	22.5	25.5	30	35	42.5	50	60
K	31.4	34	40	47	55	63	75	88
L	66	72	81	88	106	116	136	152
C1	12.5	14	16	20	25	32	38	45
C2	6	8	8	12	17	24	30	37
N	23.5	26	30	33.5	39.5	45	52.5	60
M	16	18	22	24	30	32	37	45
Q	7.5	9	9	11	11	14	17.5	20
R	4.5	5.5	5.5	6.8	6.8	9	11	14
S	15.5	15	16	13.5	16	17.5	17	23
W	30	30.5	34.5	35.5	39	48	52.5	64
G3	20	22	26	30	35.5	43.5	52.5	64
Y	11	13	13	16	19	25	28	32
C3	19	21	24	28	37	40	49	64
G2	14.5	16	18.5	21	24.5	30	36	44
D	5	6	6	6	8	10	12	15
D1	5	6	6	8	10	12	15	18
G1	37	40	47	55	61.5	72.5	82.5	100
α	19.6	20.2	18.9	19.3	20	21.4	22.4	23.1
E	17	17.5	21.5	25	26.5	30	32.5	40
G4	19	20.5	23.5	29	32	37.5	41.5	51
ΦU	Φ10	Φ12	Φ14	Φ16	Φ20	Φ22	Φ28	Φ35
配管式油口 PORT WITH LINE TYPE	2-PT1/8	2-PT1/8	2-PT1/8	2-PT1/8	2-PT1/4	2-PT1/4	2-PT3/8	2-PT3/8
油孔O型圈 (C/G型) O-RING HOLE (C/G TYPE)	P5	P5	P5	P5	P7	P7	P7	P7

### 规格参数表 SPECIFICATIONS

型号 MODEL	理论夹持力 (70 kgf/cm <sup>2</sup> ) CLAMPING FORCE AT 70 kgf/cm <sup>2</sup> (kgf)	夹紧行程 CLAMPING STROKE (mm)	总行程 TOTAL STROKE (mm)	推出容积 CYLINDER CAPACITY CLAMP (cm <sup>3</sup> )	拉入容积 CYLINDER CAPACITY UNCLAMP (cm <sup>3</sup> )	推出受压面积 EFF.PISTON AREA CLAMP (cm <sup>2</sup> )	拉入受压面积 EFF.PISTON AREA UNCLAMP (cm <sup>2</sup> )	使用温度范围 RANGE OF TEMPERATURE (°C)	使用流体 USABLE FLUID
CLKA-036	203	16	18.5	7.03	5.57	3.80	3.01	-10~+70°C	相当于ISO粘度等级的ISO-VG-32一般 液压油 Recommended: ISO-VG-32 hydraulic oil equivalent to ISO viscosity grade
CLKA-040	268	17.5	20.5	10.07	7.75	4.91	3.78	-10~+70°C	
CLKA-048	443	20.5	23.5	18.89	15.28	8.04	6.5	-10~+70°C	
CLKA-055	636	23	26	32.66	27.43	12.56	10.55	-10~+70°C	
CLKA-065	1052	26.5	29.5	57.91	48.65	19.63	16.49	-10~+70°C	
CLKA-075	1745	32	35	109.06	95.76	31.16	27.36	-10~+70°C	
CLKA-090	2093	38	41	141.37	132.55	38.48	32.33	-10~+70°C	
CLKA-105	3034	46	49	246.18	199.04	50.24	40.62	-10~+70°C	

注: 本图为CLKA-GD型夹持状态

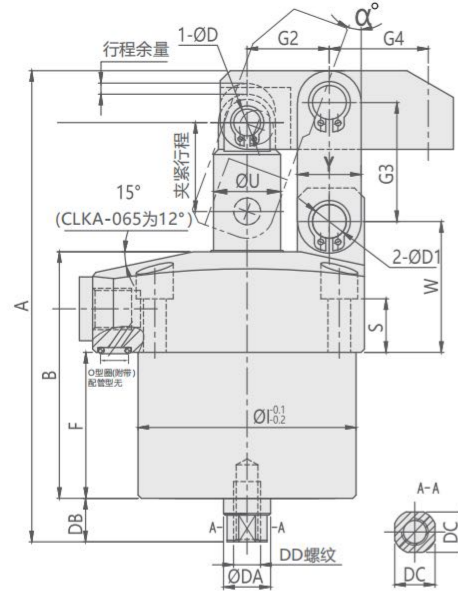

①夹持油孔 Clamping port  
②放松油孔 Unclamping port

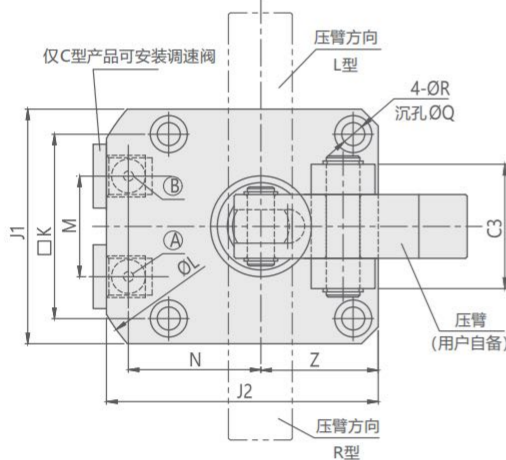

规格参数表 SPECIFICATION

型号	理论夹持力 (70 kgf/cm <sup>2</sup> )	夹紧行程	总行程	推出容积	拉入容积	推出受压面积	拉入受压面积	使用温度范围	使用流体
MODEL	CLAMPING FORCE AT 70 kgf/cm <sup>2</sup> (kgf)	CLAMPING STROKE (mm)	TOTAL STROKE(mm)	CYLINDER CAPACITY CLAMP(cm <sup>3</sup> )	CYLINDER CAPACITY UNCLAMP(cm <sup>3</sup> )	EFF.PISTON AREA CLAMP(cm <sup>2</sup> )	EFF.PISTON AREA UNCLAMP(cm <sup>2</sup> )	RANGE OF TEMPERATURE(°C)	USABLE FLUID
CLKA-036D	214	16	18.5	7.4	6.9	4.02	3.55	-10~+70°C	相当于ISO粘度等级的ISO-VG-32一般液压油 Recommended: ISO-VG-32 hydraulic oil equivalent to ISO viscosity grade
CLKA-040D	228	17.5	20.5	8.6	8.6	4.18	4.18	-10~+70°C	
CLKA-048D	304	20.5	23.5	13.0	13	5.53	5.53	-10~+70°C	
CLKA-055D	409	23	26	21.0	19.8	8.08	7.61	-10~+70°C	
CLKA-065D	771	26.5	29.5	42.4	37.7	14.4	12.8	-10~+70°C	
CLKA-075D	1187	32	35	74.2	69.8	21.2	19.94	-10~+70°C	
CLKA-090D	2052	38	41	138.5	123.7	33.8	30.2	-10~+70°C	
CLKA-105D	2880	46	49	233.8	197.8	47.7	40.35	-10~+70°C	

Unit:mm

MODEL	CLKA-036D	CLKA-040D	CLKA-048D	CLKA-055D	CLKA-065D	CLKA-075D	CLKA-090D	CLKA-105D
A	89	100.5	112	123.5	140.5	164	193	222
J2	49	54	61	69	81	94.5	109.5	127
J1	40	45	51	60	70	85	100	120
I	36	40	48	55	65	75	90	105
B	48	54	60	65	73.5	84	101	115
F	23	29	32	37	43.5	47	61	65
Z	20	22.5	25.5	30	35	42.5	50	60
K	31.4	34	40	47	55	63	75	88
L	66	72	81	88	106	116	136	152
G4	19	20.5	23.5	29	32	37.5	41.5	51
α	19.6	20.2	18.9	19.3	20	21.4	22.4	23.1
N	23.5	26	30	33.5	39.5	45	52.5	60
M	16	18	22	24	30	32	37	45
Q	7.5	9	9	11	11	14	17.5	20
R	4.5	5.5	5.5	6.8	6.8	9	11	14
S	15.5	15	16	13.5	16	17.5	17	23
W	30	30.5	34.5	35.5	39	48	52.5	64
G3	20	22	26	30	35.5	43.5	52.5	64
Y	11	13	13	16	19	25	28	32
C3	19	21	24	28	37	40	49	64
G2	14.5	16	18.5	21	24.5	30	36	44
D	5	6	6	6	8	10	12	15
D1	5	6	6	8	10	12	15	18
ΦDA	8	12	14	14	18	18	18	18
DB	10.5	13	13	13	13	13	13	13
DC	6	10	12	12	12	16	16	16
DD名称x 深度(Nominal x Depth)	M4x10	M6x15	M8x18	M8x18	M8x18	M10x21	M10x21	M10x21
ΦU	Φ10	Φ12	Φ14	Φ16	Φ20	Φ22	Φ28	Φ35
配管式油口 PORT WITH LINE TYPE	2-PT1/8	2-PT1/8	2-PT1/8	2-PT1/8	2-PT1/4	2-PT1/4	2-PT3/8	2-PT3/8
油孔O型圈 (C/G型) O-RING HOLE (C/G TYPE)	P5	P5	P5	P5	P7	P7	P7	P7

注: 本图为CLKA-GM型夹持状态

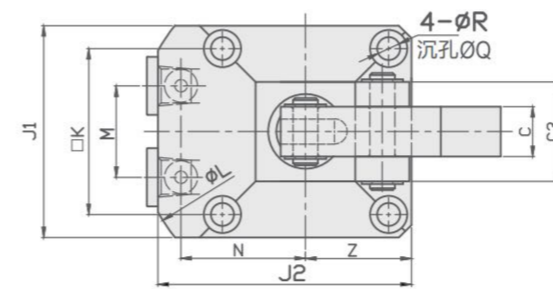
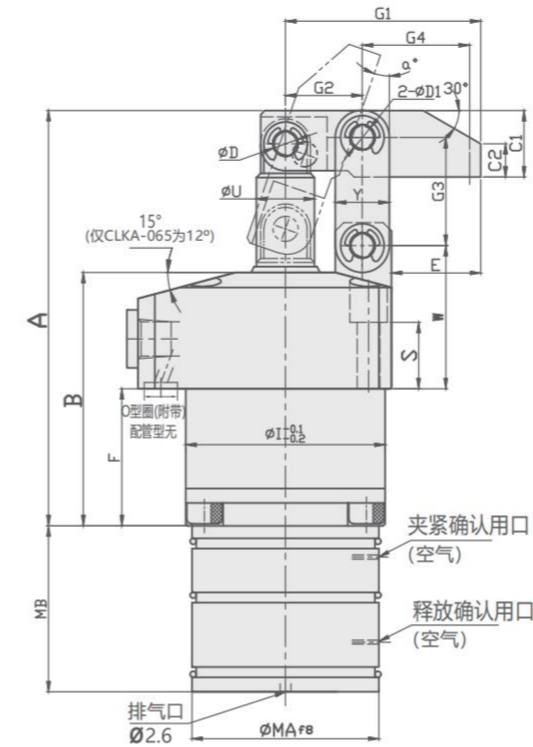
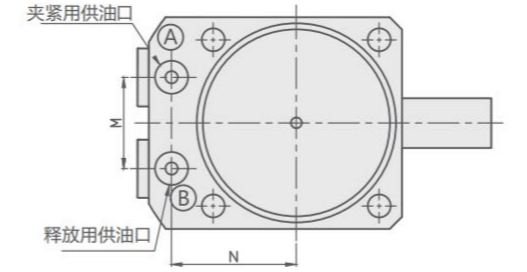

注: 安装部分加工尺寸

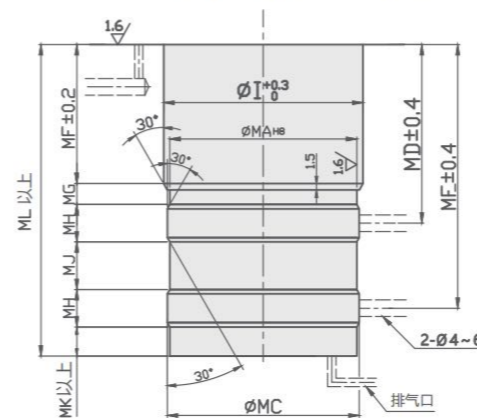

Unit:mm

MODEL	CLKA-036M	CLKA-040M	CLKA-048M	CLKA-055M	CLKA-065M	CLKA-075M	CLKA-090M	CLKA-105M
A	78.5	88.5	100	114	134.5	153	186	223
J2	49	54	61	69	81	94.5	109.5	127
J1	40	45	51	60	70	85	100	120
I	36	40	48	55	65	75	90	105
B	48	55	61	68.5	80.5	86	107	129
F	23	30	33	40.5	50.5	49	67	79
C	10	12	12	16	19	22	25	32
Z	20	22.5	25.5	30	35	42.5	50	60
K	31.4	34	40	47	55	63	75	88
L	66	72	81	88	106	116	136	152
C1	12.5	14	16	20	25	32	38	45
C2	6	8	8	12	17	24	30	37
N	23.5	26	30	33.5	39.5	45	52.5	60
M	16	18	22	24	30	32	37	45
Q	7.5	9	9	11	11	14	17.5	20
R	4.5	5.5	5.5	6.8	6.8	9	11	14
S	15.5	15	16	13.5	16	17.5	17	23
W	30	30.5	34.5	35.5	39	48	52.5	64
G3	20	22	26	30	35.5	43.5	52.5	64
Y	11	13	13	16	19	25	28	32
C3	19	21	24	28	37	40	49	64
G2	14.5	16	18.5	21	24.5	30	36	44
D	5	6	6	6	8	10	12	15
D1	5	6	6	8	10	12	15	18
G1	37	40	47	55	61.5	72.5	82.5	100
α	19.6	20.2	18.9	19.3	20	21.4	22.4	23.1
E	17	17.5	21.5	25	26.5	30	32.5	40
G4	19	20.5	23.5	29	32	37.5	41.5	51
ΦU	Φ10	Φ12	Φ14	Φ16	Φ20	Φ22	Φ28	Φ35
配管式油口 PORT WITH LINE TYPE	2-PT1/8	2-PT1/8	2-PT1/8	2-PT1/8	2-PT1/4	2-PT1/4	2-PT3/8	2-PT3/8
油孔O型圈 (C/G型) O-RING HOLE (C/G TYPE)	P5	P5	P5	P5	P7	P7	P7	P7
MAf8	34.5 <sup>-0.03</sup> <sub>-0.06</sub>	38 <sup>-0.03</sup> <sub>-0.06</sub>	45 <sup>-0.03</sup> <sub>-0.06</sub>	45 <sup>-0.03</sup> <sub>-0.06</sub>	45 <sup>-0.03</sup> <sub>-0.06</sub>	53 <sup>-0.03</sup> <sub>-0.07</sub>	53 <sup>-0.03</sup> <sub>-0.07</sub>	53 <sup>-0.03</sup> <sub>-0.07</sub>
MAH8	34.5 <sup>+0.04</sup> <sub>0</sub>	38 <sup>+0.04</sup> <sub>0</sub>	45 <sup>+0.04</sup> <sub>0</sub>	45 <sup>+0.04</sup> <sub>0</sub>	45 <sup>+0.04</sup> <sub>0</sub>	53 <sup>+0.04</sup> <sub>0</sub>	53 <sup>+0.04</sup> <sub>0</sub>	53 <sup>+0.04</sup> <sub>0</sub>
MB	31	36	40	40	40	59.5	59.5	59.5
MC	35.7	39.2	46.2	46.2	46.2	54.2	54.2	54.2
MD	32.5	40	43	50.5	60.5	61	79	91
ME	45.5	56.5	63.5	71	81	93.5	111.5	123.5
MF	23.5	30.5	33.5	41	51	49.5	67.5	79.5
MG	4.5	5	5	5	5	5.5	5.5	5.5
MH	9	9	9	9	9	12	12	12
MJ	4	7.5	11.5	11.5	11.5	20.5	20.5	20.5
MK	6	7	7	7	7	11	11	11
ML	56	68	75	82.5	92.5	110.5	128.5	140.5

①夹持油孔 Clamping port  
②放松油孔 Unclamping port

注：本图为CLKA-GN型夹持状态

Unit:mm

MODEL ITEM	CLKA-036N	CLKA-040N	CLKA-048N	CLKA-055N	CLKA-065N	CLKA-075N	CLKA-090N	CLKA-105N
A	78.5	88.5	100	114	134.5	153	186	223
J2	49	54	61	69	81	94.5	109.5	127
J1	40	45	51	60	70	85	100	120
I	36	40	48	55	65	75	90	105
B	48	55	61	68.5	80.5	86	107	129
F	23	30	33	40.5	50.5	49	67	79
C	10	12	12	16	19	22	25	32
Z	20	22.5	25.5	30	35	42.5	50	60
K	31.4	34	40	47	55	63	75	88
L	66	72	81	88	106	116	136	152
C1	12.5	14	16	20	25	32	38	45
C2	6	8	8	12	17	24	30	37
N	23.5	26	30	33.5	39.5	45	52.5	60
M	16	18	22	24	30	32	37	45
Q	7.5	9	9	11	11	14	17.5	20
R	4.5	5.5	5.5	6.8	6.8	9	11	14
S	15.5	15	16	13.5	16	17.5	17	23
W	30	30.5	34.5	35.5	39	48	52.5	64
G3	20	22	26	30	35.5	43.5	52.5	64
Y	11	13	13	16	19	25	28	32
C3	19	21	24	28	37	40	49	64
G2	14.5	16	18.5	21	24.5	30	36	44
D	5	6	6	6	8	10	12	15
D1	5	6	6	8	10	12	15	18
G1	37	40	47	55	61.5	72.5	82.5	100
α	19.6	20.2	18.9	19.3	20	21.4	22.4	23.1
E	17	17.5	21.5	25	26.5	30	32.5	40
G4	19	20.5	23.5	29	32	37.5	41.5	51
ΦU	Φ10	Φ12	Φ14	Φ16	Φ20	Φ22	Φ28	Φ35
配管式油口 PORT WITH LINE TYPE	2-PT1/8	2-PT1/8	2-PT1/8	2-PT1/8	2-PT1/4	2-PT1/4	2-PT3/8	2-PT3/8
油孔O型圈 (C/G型) O-RING HOLE (C/G TYPE)	P5	P5	P5	P5	P7	P7	P7	P7
ΦNA	35.5	39.5	45	45	45	53	53	53
NB	31	36	40	40	40	59.5	59.5	59.5
NC	9	8.5	12	12	12	20	20	20
ND	12.5	17.5	18	18	18	29.5	29.5	29.5
NE	-	1	2	2	2	3	3	3
NF	17	18.5	20	20	20	24	24	24
NG	25	29	29	29	29	38	38	38
NH(公称x深 度)(Nominal xDepth)	M3x 0.5x6	M3x 0.5x6	M3x 0.5x6	M3x 0.5x6	M3x 0.5x6	M4x 0.7x7	M4x 0.7x7	M4x 0.7x7

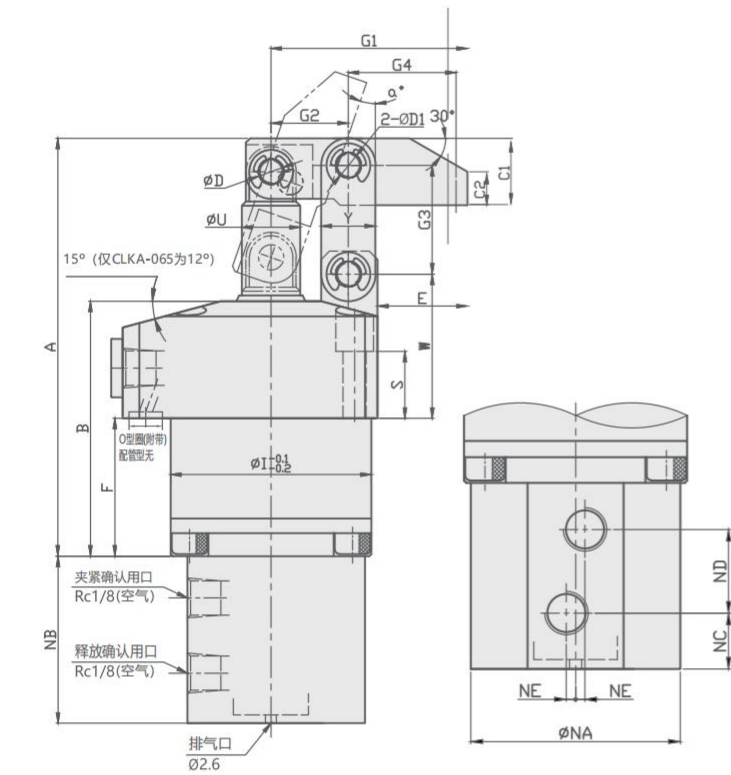
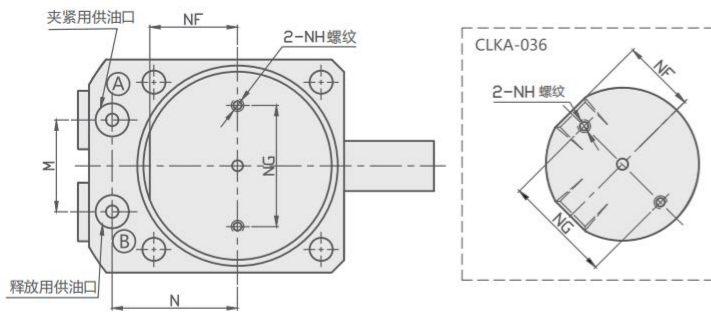

注：排气口须向大气排放，并防止冷却液切削粉等侵入。直接接触冷却液时NH螺纹处应安装配件进行防止冷却液浸入处。但是，不得堵塞排气口。

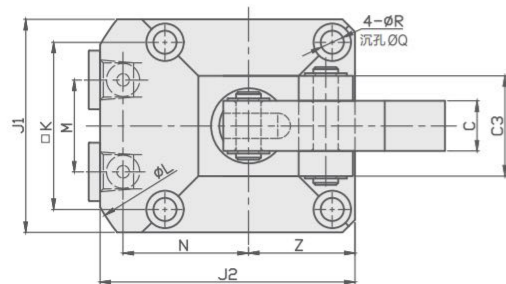

- Ⓐ 夹持油孔 Clampingport
- Ⓑ 放松油孔 Unclamping port

CLKA 压臂尺寸  
CLKA CLAMPING ARM DIMENSION

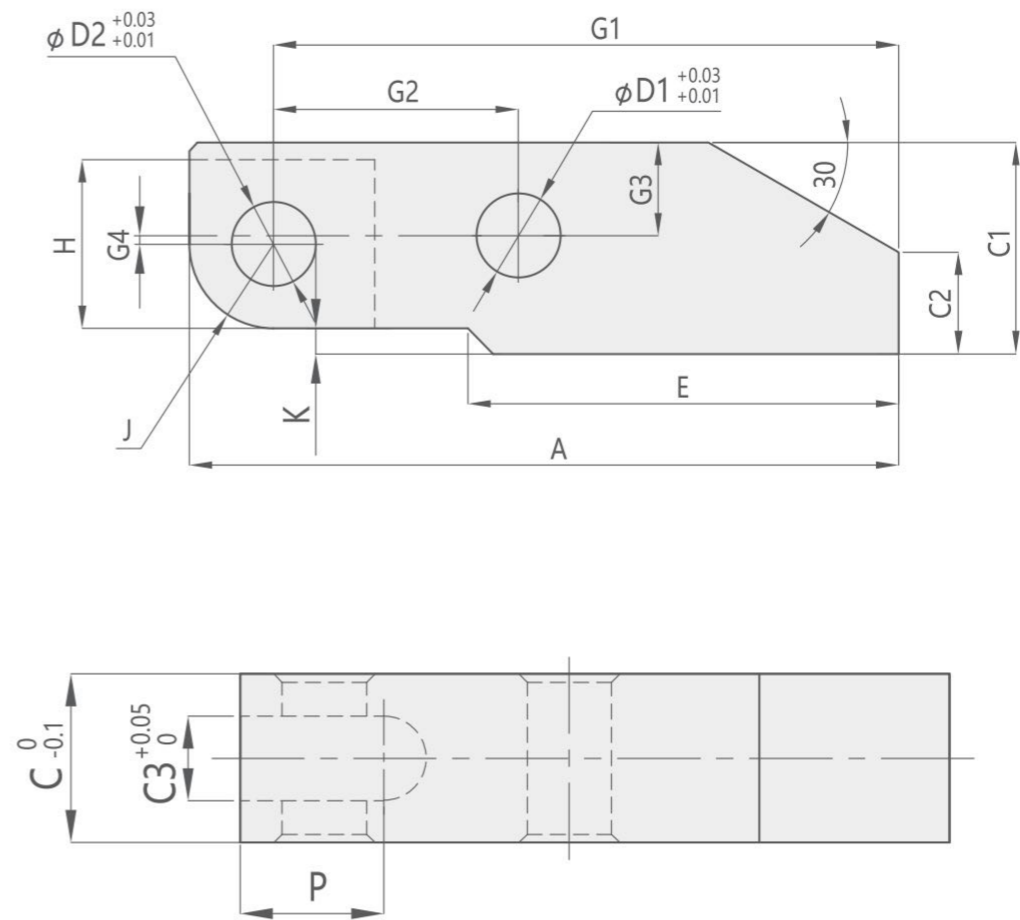

CLKA油压缸缸臂尺寸 CLKA HYDRAULIC LEVERAGE-TYPE CLAMPING ARM DIMENSIONS

Unit:mm

MODEL	A	C	C1	C2	C3	D1	D2	E	G1	G2	G3	G4	H	J	K	P
CLKA-036	42	10	12.5	6	5	5	5	25.5	37	14.5	5.5	0.5	10	R5	1.5	8.5
CLKA-040	45	12	14	8	6	6	6	27.5	40	16	6	1.5	11	R5	1.5	12
CLKA-048	53	12	16	8	6	6	6	32	47	18.5	6.5	1.5	13	R5	1.5	13
CLKA-055	61.5	16	20	12	8	8	6	37	55	21	8	4	13.5	R6	2	12.5
CLKA-065	69.5	19	25	17	10	10	8	35	61.5	24.5	9.5	6	18.5	R8	1.5	16
CLKA-075	82	22	32	24	11	12	10	42.5	72.5	30	12.5	8	21.5	R9.5	2	20.5
CLKA-090	95	25	38	30	13	15	12	60.5	82.5	36	14	8.5	27.5	R12.5	2.5	26
CLKA-105	116	32	45	37	16	18	15	68	100	44	16	6	37	R15	4	32

# CLKA-P

## 高动力&扎实型杠杆式油压缸

## CLKA-P HYDRAULIC LEVERAGE CLAMP



### 产品特性

此系列产品配件采用优化设计,与传统产品比较夹紧能力提高了。产品支撑点部位与缸体采用一体化结构,使体积更加扎实,提高了产品强度。产品采用了专用防尘设计,提高了防尘和密封性,实现了高密封性。产品法兰下部采用缩小设计,适合夹具要求的紧凑化和轻量化。

最大操作压力: 70 kgf/cm<sup>2</sup>  
最小操作压力: 10 kgf/cm<sup>2</sup>

### 注意事项

夹紧及放松动作速度需适当放缓。  
可接受定制, 欢迎与本公司洽谈。

### FEATURES

The accessories of the CLKA-P series are optimally designed and the clamping capacity has increased immensely compared to the traditional products. The cylinder and its supporting point use an integrated structure to create a more compact-sized product with enhanced strength. With its special dust-proof design, this product has improved its sealing performance and protects against any particles or debris while in use. The lower flange adopts a volume-compressed design, specifically to operate efficiently under the fixture's lightweight requirements.

Max. operating pressure: 70 kgf/cm<sup>2</sup>  
Min. operating pressure: 10 kgf/cm<sup>2</sup>

### NOTE

The action and the speed of clamping / unclamping needs to be slowed down appropriately.  
Customization is available upon request, please contact us for more info.

### 剖面图 Sectional view

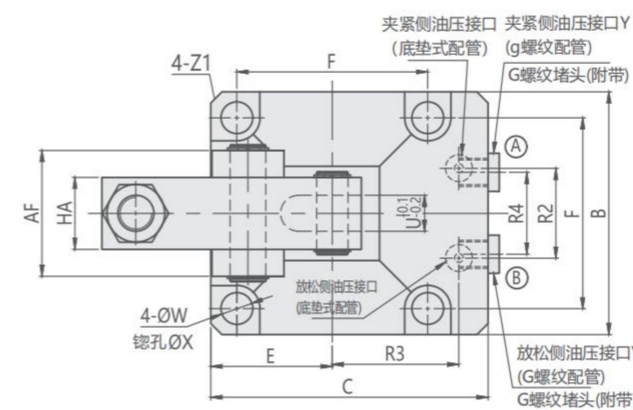
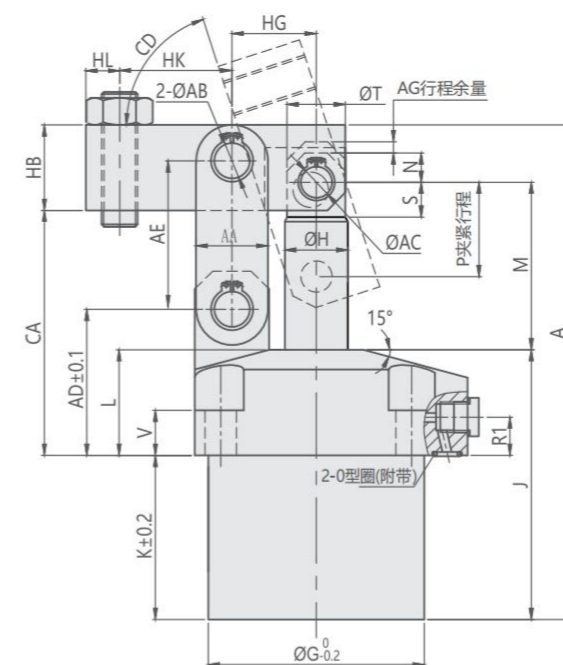
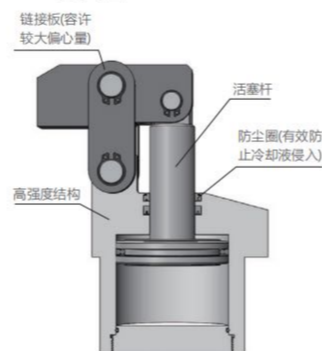

压臂安装方向 Lever Direction

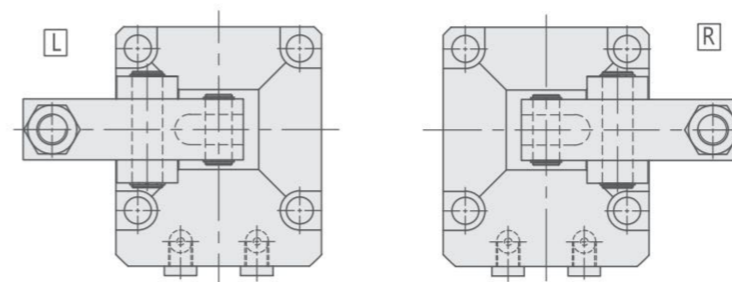

(A) 夹持油孔 Clamping port  
(B) 放松油孔 Unclamping port

### 规格参数表 SPECIFICATIONS

型号	理论夹持力 (70 kgf/cm <sup>2</sup> )	夹紧行程	总行程	推出容积	拉入容积	推出受压面积	拉入受压面积	使用温度范围	使用流体
MODEL	CLAMPING FORCE AT 70 kgf/cm <sup>2</sup> (kgf)	CLAMPING STROKE (mm)	TOTAL STROKE (mm)	CYLINDER CAPACITY CLAMP (cm <sup>3</sup> )	CYLINDER CAPACITY UNCLAMP (cm <sup>3</sup> )	EFF.PISTON AREA CLAMP (cm <sup>2</sup> )	EFF.PISTON AREA UNCLAMP (cm <sup>2</sup> )	RANGE OF TEMPERATURE (°C)	USABLE FLUID
CLKA-040P	283	17.5	20.5	10	7.7	4.9	3.77	0~+70°C	相当于ISO黏度等级的ISO-VG-32一般液压油 Recommended: ISO-VG-32 hydraulic oil equivalent to ISO viscosity grade
CLKA-048P	391	20.5	23.5	16.7	13	7.1	5.56	0~+70°C	
CLKA-055P	486	23	26	25	21	9.6	8.06	0~+70°C	
CLKA-065P	814	26.5	29.5	44.8	38.9	15.2	13.2	0~+70°C	
CLKA-075P	1346	33	36	88.6	74.5	24.6	20.66	0~+70°C	
CLKA-105P	2020	42	45	173.3	145.5	38.5	32.35	0~+70°C	

Unit:mm

MODEL ITEM	CLKA -040P	CLKA -048P	CLKA -055P	CLKA -065P	CLKA -075P	CLKA -105P
A	97	108	119.5	140	166	199
B	45	50	57	70	86	108
C	55	60	66	82	96	120
E	22.5	25	28.5	35	43	54
F	35	40	46	56	68	88
G	39	47	53	63	78	100
H	12	14	14	16	22.4	28
J	60	66	71	83	95	112
K	33.5	39.5	42.5	47	55	65
L	26.5	26.5	28.5	36	40	47
M	28.5	32	34.5	40	49	61.5
N	5	6	6	8	11	13
P	17.5	20.5	23	26.5	33	42
Q	2	2	2	2	2.5	2.5
R1	12.5	12.5	12.5	14	14	21
R2	22	24	28	36	45	50
R3	25	28	30.5	36	42	57
R4	20	22	26	30	38	50
S	6.5	7	7	9	10.8	14.5
T	10	12	12	14	20	26
U	6	6	8	10	11	16
V	16	17	17	20	20	20
W	5.5	5.5	6.8	9	11	14
X	10	10	12	15	18.5	20
Y	G1/8	G1/8	G1/8	G1/4	G1/4	G3/8
Z1	C1.5	C2.5	C2.5	C3	C3.5	C5.5
0型圈O-Ring	P7	P7	P7	P8	P8	P10
AA	11	13	15	19	25	32
AB	6 <sup>+0.012</sup> <sub>0</sub>	6 <sup>+0.012</sup> <sub>0</sub>	8 <sup>+0.015</sup> <sub>0</sub>	10 <sup>+0.015</sup> <sub>0</sub>	14 <sup>+0.018</sup> <sub>0</sub>	16 <sup>+0.018</sup> <sub>0</sub>
AC	6 <sup>+0.012</sup> <sub>0</sub>	6 <sup>+0.012</sup> <sub>0</sub>	6 <sup>+0.012</sup> <sub>0</sub>	8 <sup>+0.015</sup> <sub>0</sub>	12 <sup>+0.018</sup> <sub>0</sub>	14 <sup>+0.018</sup> <sub>0</sub>
AD	34	36	39	48	54.5	65
AE	24	26	30	35.5	44	53
AF	21	21	28	37	46	56
AG	3	3	3	3	3	3
CA	49.5	52.5	57	68	80	96
CD	约69°	约71°	约70°	约70°	约69°	约72°
HA	12	12	16	19	22	32
HB	14	16	20	25	31	38
HG	16.5	18.5	21	24.5	30.5	37.5
HK	20	23.5	29	32	39	50
HL	6	6	8	10	11	15

# C360

紧凑型杠杆油压缸

## C360 HYDRAULIC LEVERAGE CLAMP



### 产品特性

此系列产品结构紧凑，压臂可360°旋转，使用安装方便。

最大操作压力: 100kgf/cm<sup>2</sup>  
最小操作压力: 10kgf/cm<sup>2</sup>

### FEATURES

This series of products has a compact structure, the pressure arm can be rotated 360°, easy to use and install.

Max. operating pressure: 100 kgf/cm<sup>2</sup>  
Min. operating pressure: 10 kgf/cm<sup>2</sup>

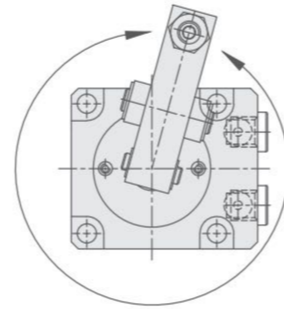

### 订购标示法 ORDERING INDICATION

示例: C360-32

<b>C360</b>	系列 Series	C360(压臂360°可旋转)
<b>32</b>	油缸内径 Hydraulic inside diameter	25/32/40/50/63

### 规格参数表 SPECIFICATIONS

型号	理论夹持力 (70kgf/cm <sup>2</sup> )	夹紧行程	总行程	推出容积	拉入容积	推出受压面积	拉入受压面积	使用温度范围	使用流体
MODEL	CLAMPING FORCE AT 70kgf/cm <sup>2</sup> (Kgf)	CLAMPLNG STROKE (mm)	TOTAL STROKE(mm)	CYLINDER CAPACITY CLAMP(cm <sup>3</sup> )	CYLINDER CAPACITY UNCLAMP(cm <sup>3</sup> )	EFF.PISTON AREA CLAMP(cm <sup>2</sup> )	EFF.PISTON AREA UNCLAMP(cm <sup>2</sup> )	RANGE OF TEMPERATURE(°C)	USABLE FLUID
C360-25	257	16.5	19.5	95.5	73.5	4.9	3.77	-10~+70°C	相当于ISO黏度等级的ISO-VG-32一般液压油 Recommended: ISO-VG-32 hydraulic oil equivalent to ISO viscosity grade
C360-32	431	20	23	184	144.9	8.0	6.3	-10~+70°C	
C360-40	667	24.5	27.5	346.5	275	12.6	10	-10~+70°C	
C360-50	1120	29.5	32.5	637	513.5	19.6	15.8	-10~+70°C	
C360-63	1739	35	38	1185.6	999.4	31.2	26.3	-10~+70°C	

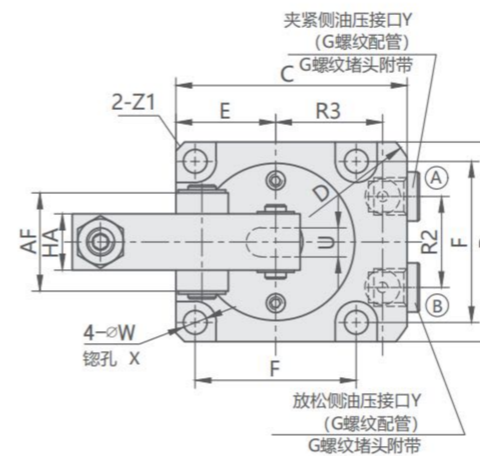
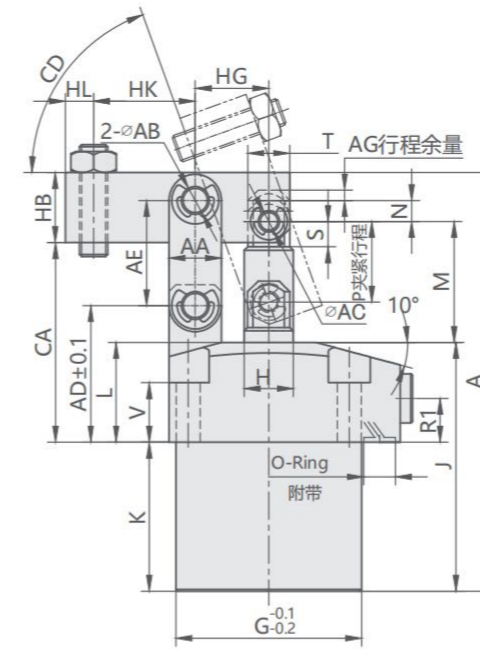

Ⓐ 夹持油孔 Clamping port  
Ⓑ 放松油孔 Unclamping port

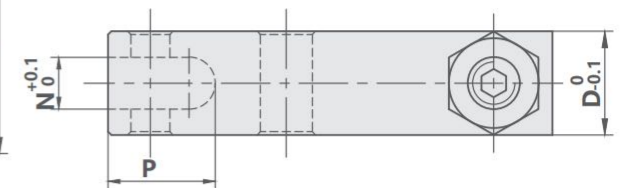
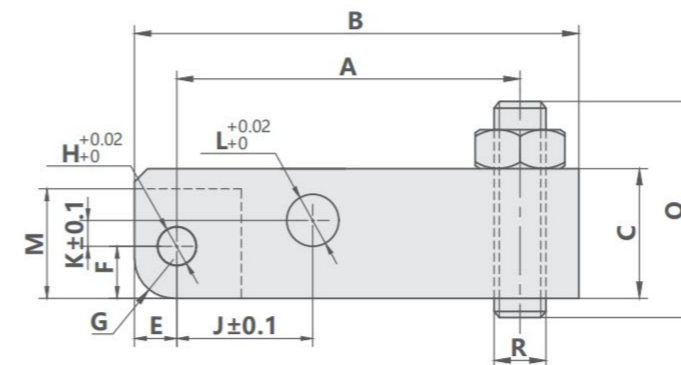

### C360系列油压杠杆缸压臂尺寸

MODEL	A	B	C	D	E	F	G	H	J	K	L	M	N	P	Q	R
C360-25	35	46	14	12	5	5	R5	Φ5	15	3	Φ6	11	5	14	25	M6
C360-32	41.5	54.5	18	14	6	6	R6	Φ6	18	5	Φ7	14	6	17	35	M8
C360-40	51	68	20	18	8	8	R8	Φ8	22	3	Φ9	18	8	22	40	M10
C360-50	59	80	25	22	10	10	R10	Φ10	26.5	4	Φ11	22	10	27	50	M12
C360-63	72	97	30	26	12	12	R12	Φ12	32	5	Φ13	27	12	33	60	M16

MODEL ITEM	C360-25	C360-32	C360-40	C360-50	C360-63
A	88.7	100	115	136.2	157.9
B	42	50	62	75	90
C	56	61	72	87.5	101
ΦD	Φ78	Φ82	Φ95	Φ114	Φ128
E	21	25	31	37.5	45
F	33	40	50	60	73
G	36	43	54	65	78
H	12	15	18	22	25
J	55.2	59	67	77.7	88.4
K	28.2	32	38	43.7	52.4
L	27	27	29	34	36
M	24.5	29	36	43.5	51.5
N	4.5	5.5	7.2	9	10.8
P	16.5	20	24.5	29.5	35
R1	13	13	13	15	15
R2	20	22	28	32	36
R3	26.5	28	33	40	46
S	6	7.2	9.6	12	14.4
ΦT	Φ10	Φ12	Φ16	Φ20	Φ24
U	5	6	8	10	12
V	20	18	17	20	20
ΦW	Φ4.8	Φ5.8	Φ6.8	Φ8.8	Φ10.8
ΦX	Φ8.5	Φ10	Φ11	Φ14	Φ17
Y	G1/8	G1/8	G1/8	G1/4	G1/4
Z1	C3	C3	C3.5	C4	C5
O型圈 O-Ring	2-P7	2-P7	2-P7	2-P9	2-P9
AA	12	14	18	22	26
ΦAB	Φ6	Φ7	Φ9	Φ11	Φ13
ΦAC	Φ5	Φ6	Φ8	Φ10	Φ12
AD	33	34	37.5	44.5	48
AE	21.5	27	30.5	37	44.5
AF	22	26	34	42	52
AG	3	3	3	3	3
CA	46.5	50	57	67.5	75.5
CD	约71°	约72°	约71°	约71°	约70°
HA	12	14	18	22	26
HB	14	18	20	25	30
HG	15	18	22	26.5	32
HK	20	23.5	29	32.5	40
HL	6	7	9	11	13

# CGL

## 多爪杠杆式油压缸

### CGL MULTI-CLAW HYDRAULIC LEVERAGE CLAMP



#### 产品特性

- 1.独特的旋转连接杆设计，使用油缸可以360度旋转设计灵活性高，节约时间。
- 2.采用外螺纹安装方式，大大缩小了安装所占面积。
- 3.与标准连杆夹具相比，显著增加了垂直夹紧行程，允许通过工件表面的孔进行夹持。
- 4.可以用一个旋转油缸夹住两个零件或通过零件孔穿过节约生产成本。
- 5.多爪缸在夹紧过程中，在夹紧面平滑的情况下，夹紧后每个压板之间的误差在1.5mm以内。
- 6.内置油压通路，能更好的防止油、水、铁等异物进入油孔、防止油缸内部堵塞导致夹具异常。
- 7.所有型号缸体大小尺寸均统一，更换型号可以避免法兰盘重新设计。
- 8.所有压板仅做展示使用，如需压板请单独购买。

最大操作压力: 250kgf/cm<sup>2</sup>  
 最小操作压力: 15kgf/cm<sup>2</sup>

#### FEATURES

1. Unique rotary connection rod design, when using the cylinder can be 360 degrees rotation, high flexibility and time saving.
2. The installation of external thread greatly reduces the area occupied by the installation.
3. Compared with the standard leverage clamp, significantly increased the vertical clamping stroke and clamping is allowed through holes in the workpiece surface.
4. Production costs can be saved by clamping two parts with one rotary cylinder or through the part hole.
5. In the clamping process of the multi-daw cylinder, when the clamping surface is smooth, the clamping error between each clamp plate is within 1.5mm.
6. Built-in oil pressure path, can better prevent oil, water, iron filling and other foreign bodies into the oil hole, to prevent internal blockage of the cylinder resulting in fixture abnormalities.
7. The size of all types of cylinder block is uniform, and the replacement model can avoid flanges redesign.
8. The clamping plates are for display purposes only. If you need them, please order separately.

Max. operating pressure: 250 kgf/cm<sup>2</sup>  
 Min. operating pressure: 15 kgf/cm<sup>2</sup>

#### 注意事项 NOTE

夹紧及放松动作速度需适当放缓  
 压板及配件仅做展示使用，压板可定制，如需要请联系我们。

The action and the speed of clamping / unclamping needs to be slowed down appropriately.

All pressure plates are for display only, and customization is available upon request, please contact us for more info.

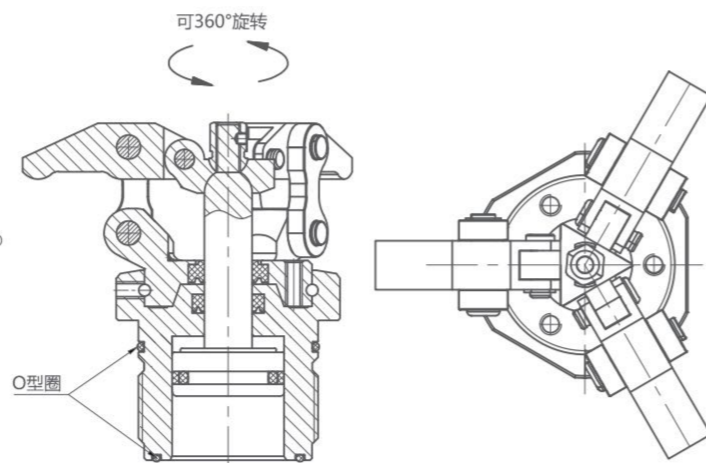

#### 订购标示法 ORDERING INDICATION

示例: CGLS-HG

CGL	系列Series	CGL	
S	油缸类型 Cylinder type	E 两爪缸 S 三爪缸	E Two-jaw cylinder S Three-jaw cylinder
	油压压力 Cylinder pressure	LG 标准型 HG 增力型	LG Standard type HG Reinforcement type

型号	油压在 25MPa时	活塞杆夹紧行程	有效活塞面积(夹紧)	机油容量 OIL CAPACITY(cm <sup>3</sup> )		最大流量
MODEL	CLAMPING FORCE AT 25MPa(KN)	PISTON ROD CLAMPING STROKE(mm)	EFF.PISTON AREA CLAMP(cm <sup>2</sup> )	夹紧 CLAMP	放松 UNCLAMP	MAX.FLOW (cm <sup>3</sup> /s)
CGLE-LG	3	16	1.76	2.3	8.4	0.45
CGLE-HG	9	16	6.15	0.8	0.8	1.67
CGLS-LG	3	16	1.76	2.3	8.4	0.45
CGLS-HG	9	16	6.15	8.4	0.8	1.67

#### CGL多爪杠杆式油压缸外形尺寸图

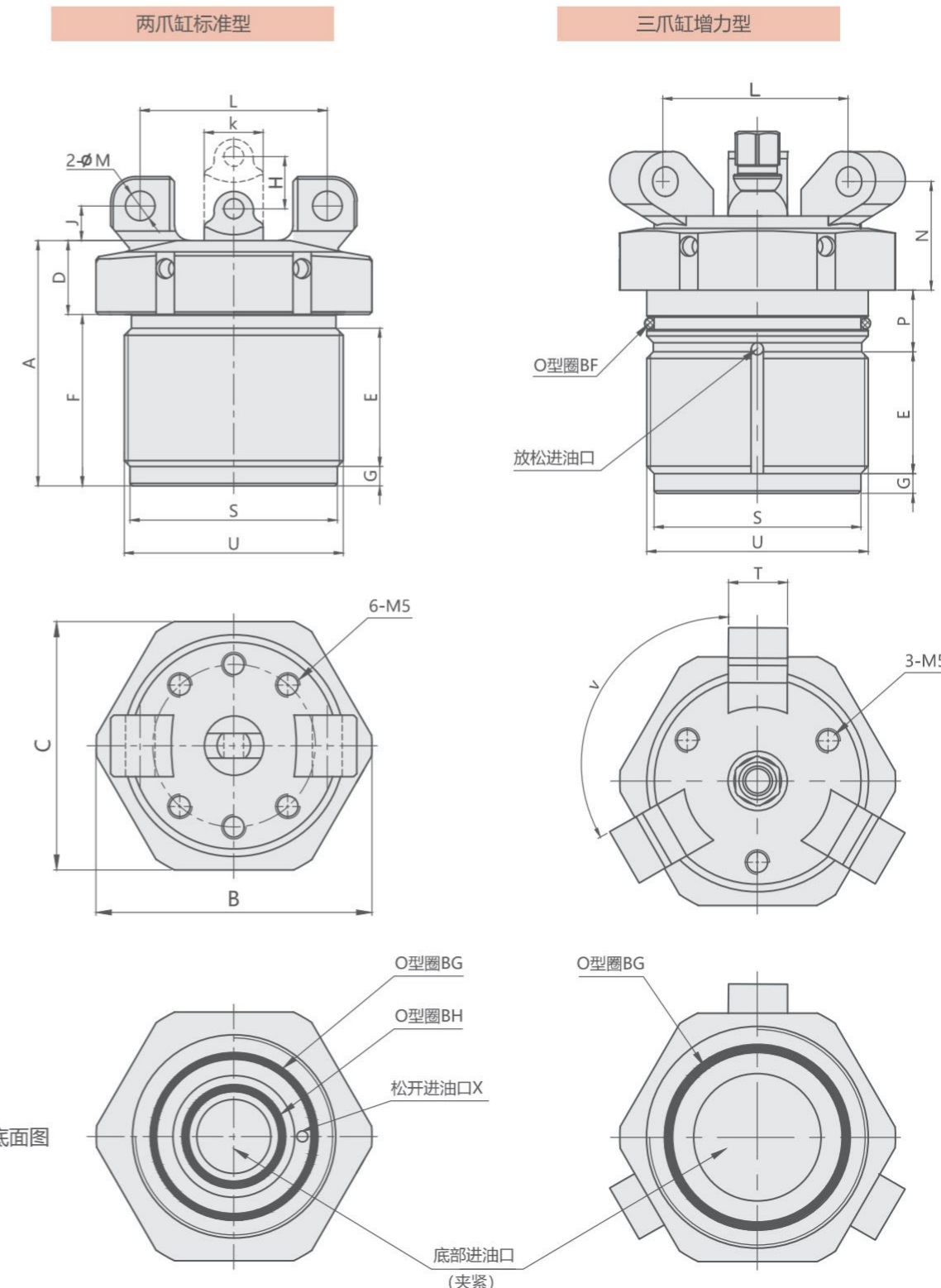

CGL多爪缸杆式油缸安装尺寸图

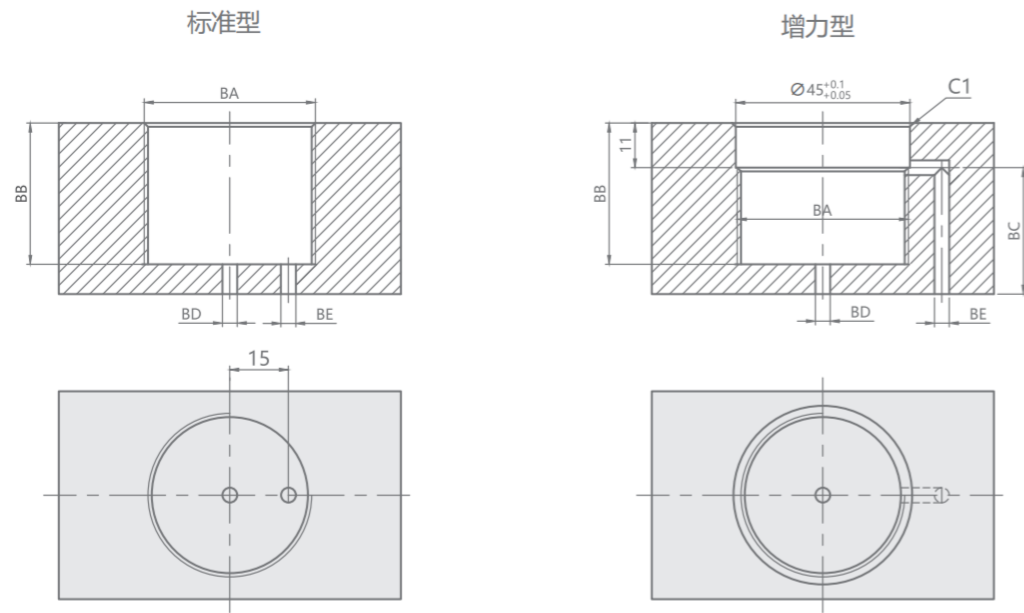

型号	单位	CGLE-LG	CGLE-HG	CGLS-LG	CGLS-HG
A	mm	50	50	50	50
B	mm	56	56	56	56
C	mm	50.5	50.5	50.5	50.5
D	mm	15	15	15	15
F	mm	35	-	35	-
E	mm	28	18.5	28	18.5
G	mm	4	4	4	4
Max.H	mm	16	16	16	16
J	mm	7	7	7	7
K	mm	12	12	12	12
L	mm	38	38	37.8	37.8
ΦM	mm	6	6	6	6
N	mm	22	22	22	22
P	mm	-	12.5	-	12.5
∅Q	mm	4	4	4	4
∅R	mm	5	5	5	5
S	mm	42	42	42	42
T	mm	12	12	12	12
U	mm	M45*1.5	M45*1.5	M45*1.5	M45*1.5
V	°	180	180	180	180
BA	mm	M45*1.5	M45*1.5	M45*1.5	M45*1.5
BB	mm	35	35	35	35
BC	mm	-	23	-	23
BD	mm	3	3	3	3
BE	mm	3	3	3	3
X	mm	3	3	3	3
o型圈	BF mm	-	41.5 x2	-	41.5 x2
	BG mm	AS028 34.65*1.78	AOS028 34.65*1.78	AS028 34.65*1.78	AS028 34.65*1.78
	BH mm	AS018 18.77*1.78	-	AS018 18.77*1.78	-

压板型号说明

CGL	*	-	*
多爪缸杆式油压	油缸类型		压板类型
	E 两爪缸		01标准压板
	S 三爪缸		02可安装压钉标准压板

\*所有图中展示均为嘉刚标准压板压钉尺寸，特殊尺寸和压钉需联系客服定制；  
\*压板、压钉带安装配件需另外购买，如不需要购买，零件内容尺寸请联系客服；

压板外形尺寸图

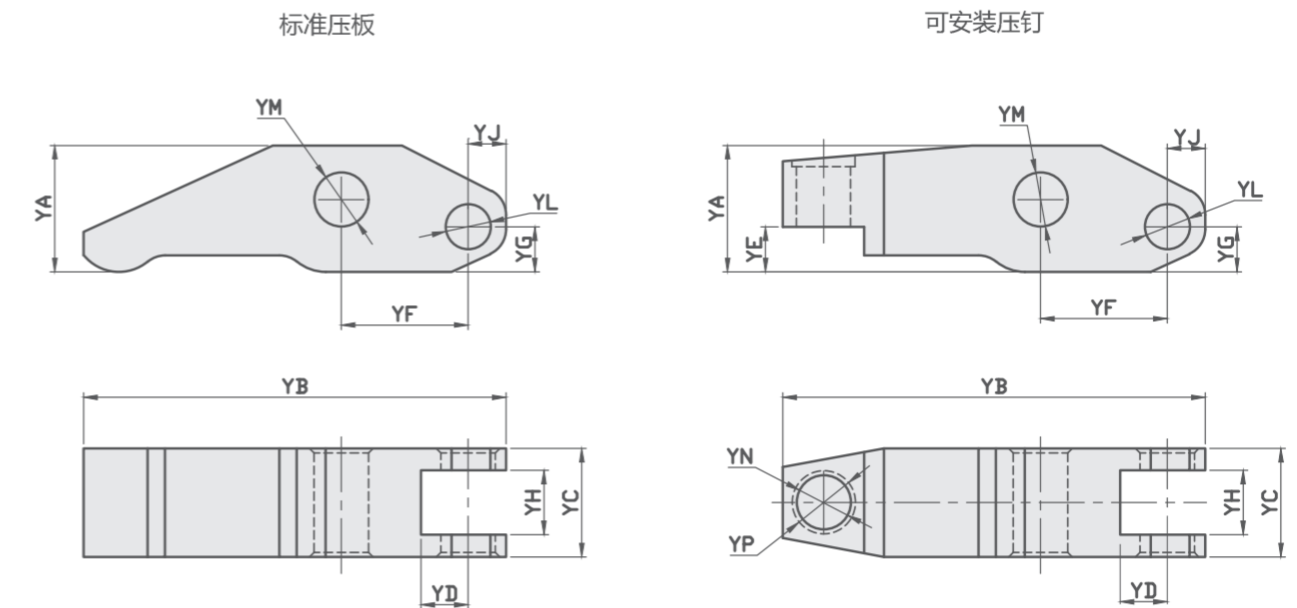

型号	单位	CGLE-LG	CGLS-HG
YA	mm	14	14
YB	mm	45	42.5
YC	mm	12	12
YD	mm	5.2	5.2
YE	mm	-	5
YF	mm	14	14
YG	mm	5	5
YH	mm	7.1	7.1
YJ	mm	4.2	4.2
YK	mm	6	6
YL	mm	5	5
YM	mm	6	6
YN	mm	-	6
YP	mm	-	7

# CBLU

## 方块&紧凑型 杠杆式油压缸

## CBLU HYDRAULIC LEVERAGE CLAMP



### 产品特性

此系列产品配件采用优化设计,与传统产品比较夹紧能力提高了。产品支撑点部位与缸体采用一体化结构,使体积更加紧凑提高了产品强度。产品采用了专用防尘设计,提高了防尘和密封性,实现了高密封性。产品采用方块型设计,不需垫块安装方便。

最大操作压力: 70 kgf/cm<sup>2</sup>  
最小操作压力: 10 kgf/cm<sup>2</sup>

### 注意事项

夹紧及放松动作速度需适当放缓。

### FEATURES

The accessories of the CBLU series are optimally designed and the clamping capacity has increased immensely compared to the traditional products. The cylinder and its supporting point use an integrated structure to create a more compact-sized product with enhanced strength. With its special dust-proof design, this product has improved its sealing performance and protects against any particles or debris while in use. The product has been developed with a block-shape construction for easy and smooth installation.

Max. operating pressure: 70 kgf/cm<sup>2</sup>  
Min. operating pressure: 10 kgf/cm<sup>2</sup>

### NOTE

The action and the speed of clamping / unclamping needs to be slowed down appropriately.

### 剖面图 Sectional view

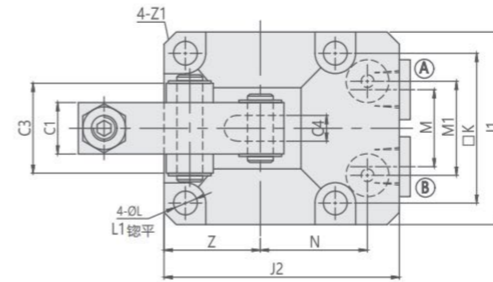
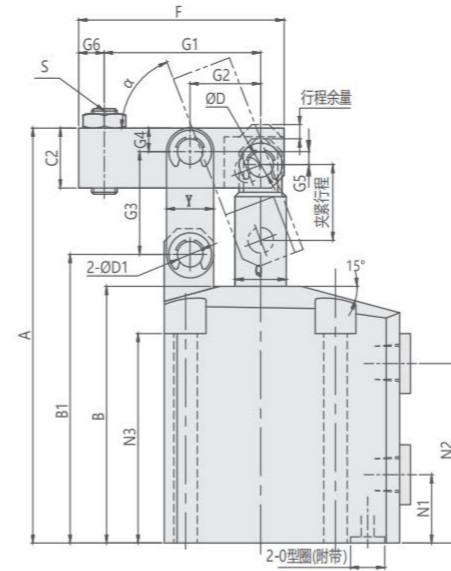
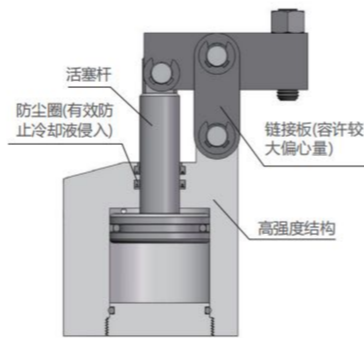

压臂安装方向 Lever Direction

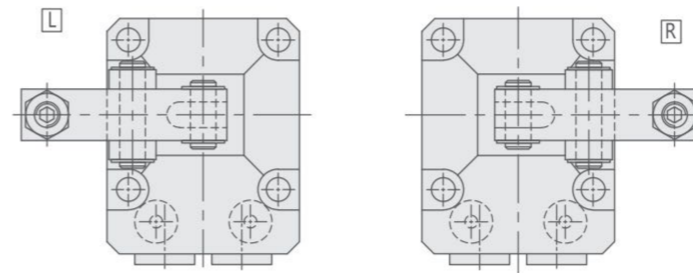

① 夹持油孔 Clamping port  
② 放松油孔 Unclamping port

MODEL ITEM	CBLU -25	CBLU -30	CBLU -35	CBLU -45	CBLU -55	CBLU -70
A	97	108	119.5	140	166	199
B	60	66	71	83	95	112
B1	67.5	75.5	81.5	95	109.5	130
C1	12	12	16	19	22	32
C2	14	16	20	25	31	38
C3	21	21	28	37	46	56
C4	6	6	8	10	11	16
D	Φ6	Φ6	Φ6	Φ8	Φ12	Φ14
D1	Φ6	Φ6	Φ8	Φ10	Φ14	Φ16
F	48.5	54	64	73.5	90.5	115.5
G1	36.5	42	50	56.5	69.5	87.5
G2	16.5	18.5	21	24.5	30.5	37.5
G3	24	26	30	35.5	44	53
G4	5.5	6.5	8	9.5	12.5	16
G5	3	3.5	6	7.5	9.5	9.5
G6	6	6	8	10	11	15
J1	45	50	57	70	86	108
J2	55	60	66	82	96	120
K	35	40	46	56	68	88
L	Φ5.5	Φ5.5	Φ6.8	Φ9	Φ11	Φ14
L1	Φ9.5	Φ9.5	Φ11	Φ14	Φ17.5	Φ20
M	20	22	26	30	38	50
M1	22	24	28	36	45	50
N	25	28	30.5	36	42	57
N1	16	17	17	22	23	28
N2	42	48	51	56.5	64.5	80.5
N3	49	54	57	66	73.5	83
Z	22.5	25	28.5	35	43	54
Z1	C3	C3	C3	C4	C6	C6.5
S	M6x25	M6x25	M8x30	M10x40	M12x50	M16x60
α	69°	71°	70°	70°	69°	72°
Y	11	13	15	19	25	32
Q	Φ12	Φ14	Φ14	Φ16	Φ22	Φ28
配管式油口 PORT WITH LINE TYPE	PT1/8	PT1/8	PT1/8	PT1/4	PT1/4	PT3/8
油孔O型圈 (C型) O-RING HOLE (C TYPE)	P7	P7	P7	P8	P8	P10

### 订购标示法 ORDERING INDICATION

#### 示例: CBLU-30CL

CBLU	系列 Series	CBLU
30	油缸内径 Hydraulic cylinder inside diameter	Φ 25, Φ 30, Φ 35, Φ 45 Φ 55, Φ 70
C	油口型式 Port type	空白: 配管式 G: 油路板式 C: 油路板式附调速  Blank: Line type G: Manifold type C: Manifold with flow type
L	压臂安装方向 Lever direction	空白: 标准 L: 左 R: 右  Blank: Standard L: Left R: Right

### 规格参数表 SPECIFICATIONS

型号	理论夹持力 (70 kgf/cm <sup>2</sup> )	夹紧行程	总行程	推出容积	拉入容积	推出受压面积	拉入受压面积	使用温度范围	使用流体
MODEL	CLAMPING FORCE AT 70 kgf/cm <sup>2</sup> (kgf)	CLAMPING STROKE (mm)	TOTAL STROKE(mm)	CYLINDER CAPACITY CLAMP(cm <sup>3</sup> )	CYLINDER CAPACITY UNCLAMP(cm <sup>3</sup> )	EFF.PISTON AREA CLAMP(cm <sup>2</sup> )	EFF.PISTON AREA UNCLAMP(cm <sup>2</sup> )	RANGE OF TEMPERATURE(°C)	USABLE FLUID
CBLU-25	283	17.5	20.5	10.00	5.69	4.91	2.78	-10~+70°C	相当于ISO黏度等级的ISO-VG-32一般液压油 Recommended: ISO-VG-32 hydraulic oil equivalent to ISO viscosity grade
CBLU-30	391	20.5	23.5	16.60	13.00	7.07	5.53	-10~+70°C	
CBLU-35	486	23	26	25.00	21.00	9.62	8.08	-10~+70°C	
CBLU-45	852	26.5	29.5	46.90	41.00	15.90	13.90	-10~+70°C	
CBLU-55	1300	33	36	85.50	71.80	23.75	19.95	-10~+70°C	
CBLU-70	2020	42	45	173.10	145.40	38.47	32.32	-10~+70°C	

# CLF5H

连杆气/油压缸 (眼镜蛇缸)

## CLF5H PNEUMATIC / HYDRAULIC LEVERAGE CLAMP



### 产品特性

此系列产品设计中采用连杆机构,在解除夹持状态时,压臂可拉到低于夹持面的位置,减少对工件装卸的干涉,因此操作方便,缸体采用一体成型。

产品动作轨迹非常小,用传统的转角缸/缸杆缸都难以夹持到的部位均可以达到夹持作用,并可以减少对周围机器设备的干扰,达到节省工作空间的目的。产品采用了专用防尘设计,防止了切削及冷却液的渗入,实现了高密封性,因此在比较恶劣的环境下也能使用。

油缸 最大操作压力: 70 kgf/cm<sup>2</sup>  
最小操作压力: 10 kgf/cm<sup>2</sup>  
气缸 最大操作压力: 7 kgf/cm<sup>2</sup>  
最小操作压力: 3 kgf/cm<sup>2</sup>

### 注意事项

夹紧及放松动作速度需适当放缓。  
气缸缸体材料为铝合金。

### FEATURES

The design of the CLF5H series uses an integrated structure that features a linkage mechanism. The clamping arm can be pulled to a position lower than the damping surface when the clamp is released and helps minimize any interference during the loading/unloading of the workpiece. This hydraulic leverage cylinder uses minimal motion trajectory and is capable of achieving the clamping effect to the placements that are generally difficult to be clamped by the traditional swing/leverage cylinders. This product is able to save work space and minimize the interference to the surrounding machinery and equipment. With its special dust-proof design, this product has improved its sealing performance that protects against the penetration of cutting or coolant and is made to endure harsh industrial environments.

**Hydraulic type** Max. operating pressure: 70 kgf/cm<sup>2</sup>  
Min. operating pressure: 10 kgf/cm<sup>2</sup>  
**Pneumatic type** Max. operating pressure: 7 kgf/cm<sup>2</sup>  
Min. operating pressure: 3 kgf/cm<sup>2</sup>

### NOTE

The action and the speed of clamping / unclamping needs to be slowed down appropriately.  
The material of pneumatic type is AL.

剖面图 Sectional view

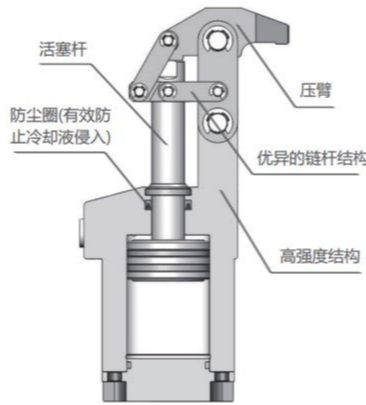

LINE TYPE 配管式

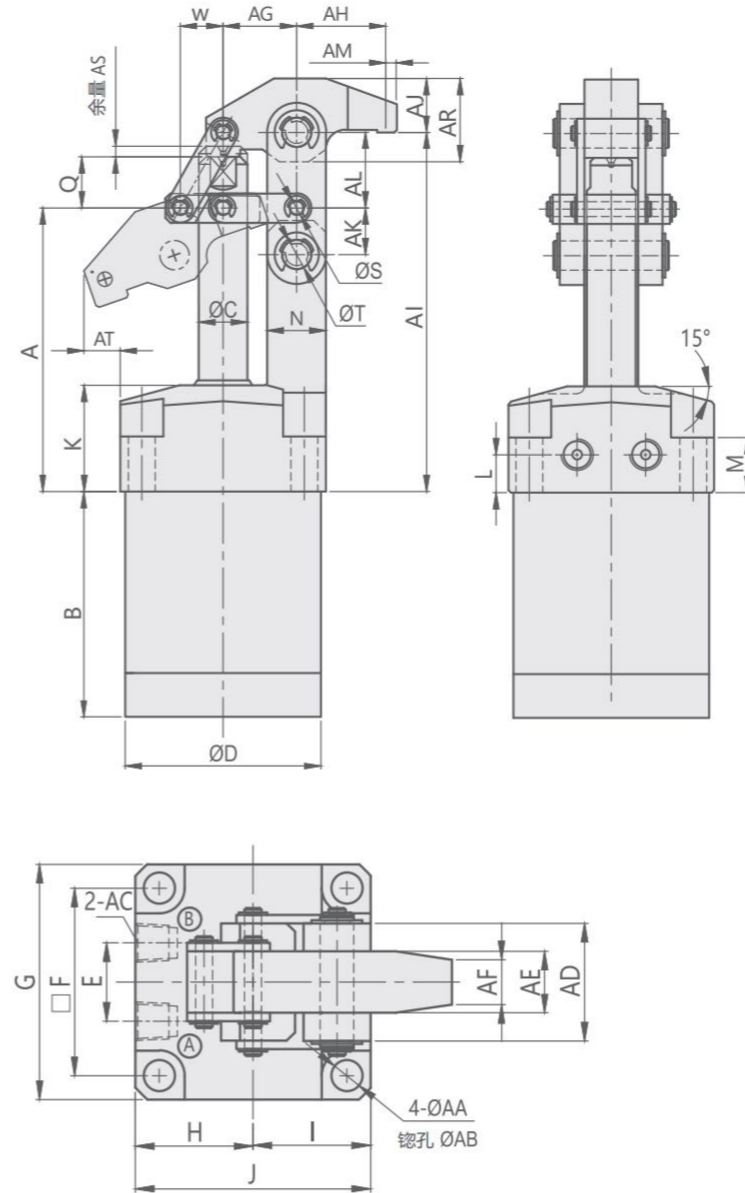

Ⓐ 夹持油孔 Clamping port  
Ⓑ 放松油孔 Unclamping port

MODEL ITEM	CLF5H-25	CLF5H-32	CLF5H-40	CLF5H-50
A	70	75	89.5	101.5
B	59.5	70.5	79.5	86.5
C	14	14	16	20
D	47	55	65	80
E	21	21	25	28
F	40	47	55	67
G	50	59	69	84
H	25	29.5	34.5	42
I	25	29.5	34.5	42
J	50	59	69	84
K	30.5	30.5	37.5	43.5
L	11.5	11.5	13.5	15.5
M	16	15.5	20.5	22.5
N	12	16	20	24
Q	12	14	20	21
S	5	5	6	6
T	6	8	10	12
U	56.5	60	72	83
W	13	13	16	17.5
AA	5.5	6.6	9	11
AB	9.5	11	14	18
AC	PT1/8	PT1/8	PT1/4	PT1/4
AD	22	28	36	42
AE	12	16	19	22
AF	8	12	14	16
AG	19	21.5	24.5	30
AH	23	28	31	37
AI	88	95	117.5	132.5
AJ	13	15	18	22
AK	13.5	15	17.5	19
AL	18	20	28	31
AM	4	4	4	4
AR	20	23	28	34
AT	12	11	18	15
退臂量	16	16	22.5	25.5

### 规格参数表 SPECIFICATIONS

型号	理论夹持力 CLAMPING FORCE	夹紧行程	总行程	推出容积	拉入容积	推出受压面积	拉入受压面积	使用温度范围	使用流体
MODEL	油压在70 kgf/cm <sup>2</sup> AT 70 kgf/cm <sup>2</sup> (kgf)	CLAMPING STROKE (mm)	TOTAL STROKE(mm)	CYLINDER CAPACITY CLAMP(cm <sup>3</sup> )	CYLINDER CAPACITY UNCLAMP(cm <sup>3</sup> )	EFF.PISTON AREA CLAMP(cm <sup>2</sup> )	EFF.PISTON AREA UNCLAMP(cm <sup>2</sup> )	RANGE OF TEMPERATURE(°C)	USABLE FLUID
CLF5H-25	290	29	31.5	34	16.69	11.46	4.91	3.37	-10~+70°C
CLF5H-32	441	44.1	35.5	38	30.55	25.08	8.04	6.60	-10~+70°C
CLF5H-40	709	70.9	41	44	55.26	46.46	12.56	10.56	-10~+70°C
CLF5H-50	1136	113	47	50	98.15	82.45	19.63	16.49	-10~+70°C

相当于 ISO 粘度等级的 ISO-VG-32 一般液压油, 气动款使用干燥之压缩空气。  
Recommended: ISO-VG-32 hydraulic oil equivalent to ISO viscosity grade. Filtered dry compressed air for pneumatic type.

### 订购标示法 ORDERING INDICATION

示例: CLF5H-32GQ

CLF5H	系列 Series	CLF5H
32	缸内径 Hydraulic cylinder inside diameter	Φ 25, Φ 32, Φ 40, Φ 50
G	型式 Port type	空白: 配管式 G: 板式 Blank: Line type G: Manifold type
Q	驱动方式 Working type	空白: 油压缸 Q: 气压缸 Blank: Hydraulic Q: Pneumatic

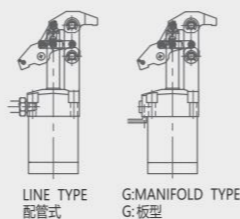

**G: MANIFOLD TYPE G油路板型**

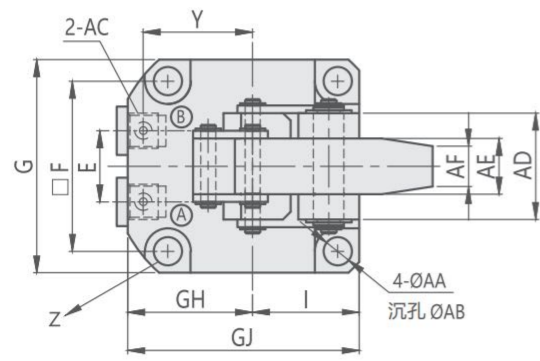
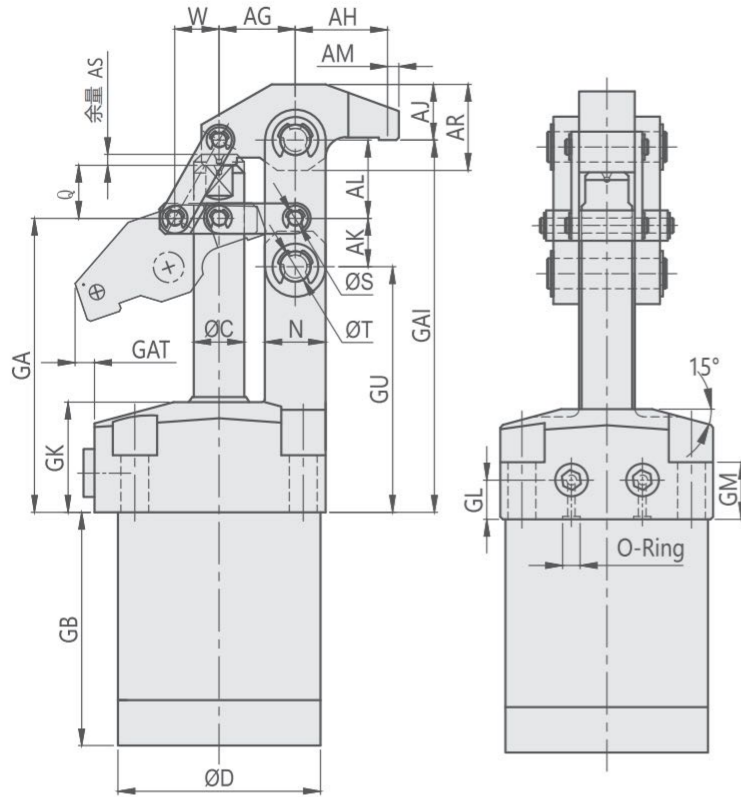

- Ⓐ 夹持油孔 Clamping port
- Ⓑ 放松油孔 Unclamping port

Unit:mm

MODEL ITEM	CLF5H-25G	CLF5H-32G	CLF5H-40G	CLF5H-50G
GA	70.5	75.5	90	102
GB	59	70	79	86
C	14	14	16	20
D	47	55	65	80
E	21	21	25	28
F	40	47	55	67
G	50	59	69	84
GH	35	37.5	45.5	51
I	25	29.5	34.5	42
GJ	60	67	80	93
GK	31	31	38	44
GL	12	12	14	16
GM	18	17	21	23
N	12	16	20	24
Q	12	14	20	21
S	4	5	6	6
T	6	8	10	12
GU	57	60.5	72.5	83
W	13	13	16	17.5
O型圈 O-Ring	S4	S4	S4	P5
Y	29	32	37	44
Z	R39	R43	R51	R57
AA	5.5	6.6	9	11
AB	9.5	11	14	18
AC	G1/8	G1/8	G1/4	G1/4
AD	22	28	36	42
AE	12	16	19	22
AF	8	12	14	16
AG	19	21.5	24.5	30
AH	23	28	31	37
GAI	88.5	95.5	118	133
AJ	13	15	18	22
AK	13.5	15	17.5	19
AL	18	20	28	31
AM	4	4	4	4
AR	20	23	28	34
GAT	2	3	7	6
退臂量	16	16	22.5	25.5

**动作轨迹和退臂量**

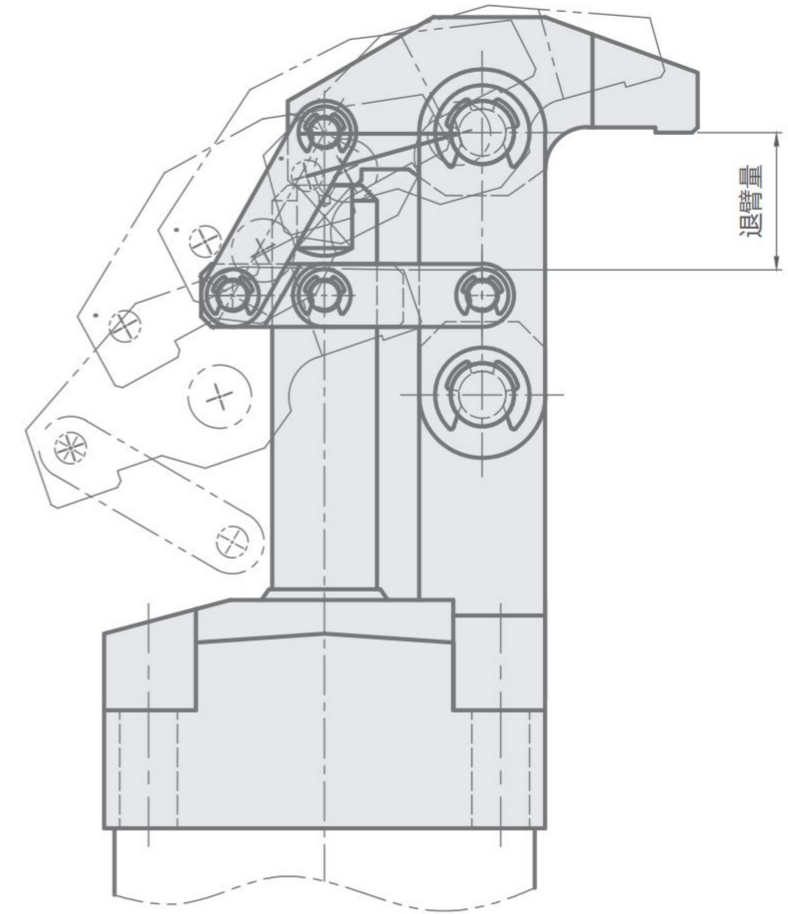

**CLF5H PNEUMATIC /  
HYDRAULIC LEVERAGE CLAMP**

# CHLC

## 杠杆式油压缸

### CHLC HYDRAULIC LEVERAGE CLAMP



#### 产品特性

此型式油压缸夹持机构为杆原理,活塞推出为夹紧状态夹持力大于转角缸,主要机构零件安装在缸体外部,易于维护。  
缸体及夹持机构材料均采用机械构造用碳素钢,坚固耐用,使用寿命长。活塞材质采用45钢,热处理表面镀铬。

最大操作压力: 70 kgf/cm<sup>2</sup>  
最小操作压力: 10 kgf/cm<sup>2</sup>  
作用方式: 复动式

#### 注意事项

夹紧及放松动作速度需适当放缓。

#### FEATURES

The clamping mechanism used on this hydraulic cylinder is based on the principle of leverage. The clamping force of the leverage clamps is greater than the swing clamps. When the piston rod is pushed out, the cylinder is in a clamped state. The main component parts are externally installed which is optimal for product maintenance. The CHLC hydraulic cylinders are manufactured with industrial-grade carbon steel for increased durability and extended product lifespan. The piston rod is made of heat-treated 45 steel and chrome-plated surface.

Max. operating pressure: 70 kgf/cm<sup>2</sup>  
Min. operating pressure: 10 kgf/cm<sup>2</sup>  
Double acting

#### 剖面图 Sectional view

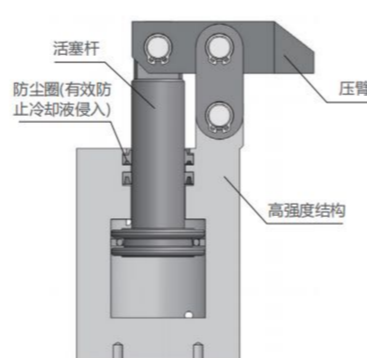

#### LINE TYPE 配管式

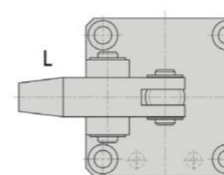
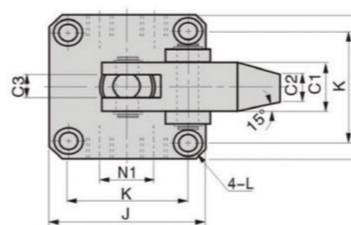
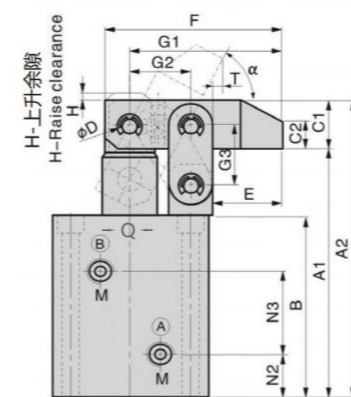

#### M: MANIFOLD TYPE M油路板型

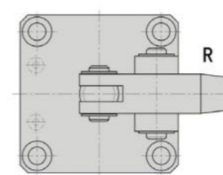
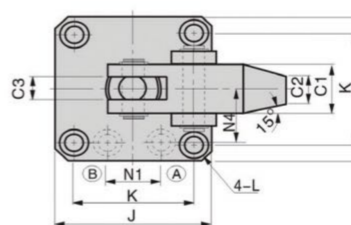
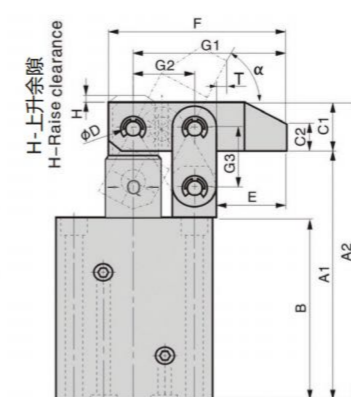

- Ⓐ 夹持油孔 Clamping port
- Ⓑ 放松油孔 Unclamping port

MODEL	CHLC-25	CHLC-32	CHLC-40	CHLC-50	CHLC-63
ITEM	CHLC-M25	CHLC-M32	CHLC-M40	CHLC-M50	CHLC-M63

A1	103	112	122	137	155
A2	122	131	144	162	187
B	76	85	90	100	111
C1	□19	□19	□22	□25	□32
C2	11	11	13	15	19
C3	9	9	10	11	15
ΦD	Φ8	Φ8	Φ10	Φ12	Φ15
E	25	25	30	35.5	43
F	64	64	77	90	110
G1	55	55	66	77	94
G2	22	22	26	30	36
G3	24	24	29	33	39
H	3	3	4	4	4
J	55	57	69	75	96
K	42	44	52	58	75
L	Φ6.8-Φ10.5 ×6.5D	Φ6.8-Φ10.5 ×6.5D	Φ9-Φ14 ×9D	Φ9-Φ14 ×9D	Φ11-Φ18 ×11D
M	PT1/8	PT1/8	PT1/4	PT1/4	PT1/4
N1	18	22	26	32	38
N2	17	19	19	21.5	22
N3	33	38	40	45	52
N4	20	22	26	29	38
O型圈 O-Ring	P7	P7	P8	P7	P9
α	61°	61°	61°	61°	66°
T	4	5	5.5	7.5	2
Q	Φ18	Φ20	Φ22.4	Φ28	Φ35.5

#### 订购标示法 ORDERING INDICATION

##### 示例: CHLC - M25RA

CHLC	系列 Series	CHLC
M	型式 Type	空白: 配管式 M: 油路板型 MF: 油路板型附调速 FA: 法兰型 FAM: 法兰型油路板 FAMT: 法兰型附调速 注: 详情见后面图 Note: Please refer to the CAD drawing for the details.
25	油缸内径 Hydraulic cylinder inside diameter	Φ25, Φ32, Φ40 Φ50, Φ63
R	压臂安装方向 Lever direction	L: 左 R: 右
A	一体成型 A: Integrated	

备注: 配管式, MF油路板型附调速以及FA法兰型只有单一方向。  
Note: The line type, MF and FA only have single direction.

#### 规格参数表 SPECIFICATIONS

型号	理论夹持力 (70 kgf/cm <sup>2</sup> )	夹紧行程	总行程	推出容积	拉入容积	推出受压面积	拉入受压面积	使用温度范围	使用流体
MODEL	CLAMPING FORCE AT 70 kgf/cm <sup>2</sup> (kgf)	CLAMPING STROKE (mm)	TOTAL STROKE (mm)	CYLINDER CAPACITY CLAMP (cm <sup>3</sup> )	CYLINDER CAPACITY UNCLAMP (cm <sup>3</sup> )	EFF.PISTON AREA CLAMP (cm <sup>2</sup> )	EFF.PISTON AREA UNCLAMP (cm <sup>2</sup> )	RANGE OF TEMPERATURE (°C)	USABLE FLUID
CHLC-25	252	22	25	12.28	5.93	4.91	2.37	-10~+70°C	相当于ISO黏度等级的ISO-VG-32一般液压油 Recommended: ISO-VG-32 hydraulic oil equivalent to ISO viscosity grade
CHLC-32	412	22	25	20.10	12.25	8.04	4.9	-10~+70°C	
CHLC-40	618	26	30	37.68	25.86	12.56	8.62	-10~+70°C	
CHLC-50	981	30	34	66.74	45.80	19.63	13.47	-10~+70°C	
CHLC-63	1482	40	44	124.64	85.04	31.16	21.26	-10~+70°C	

油路板附调速 CHLC-MF

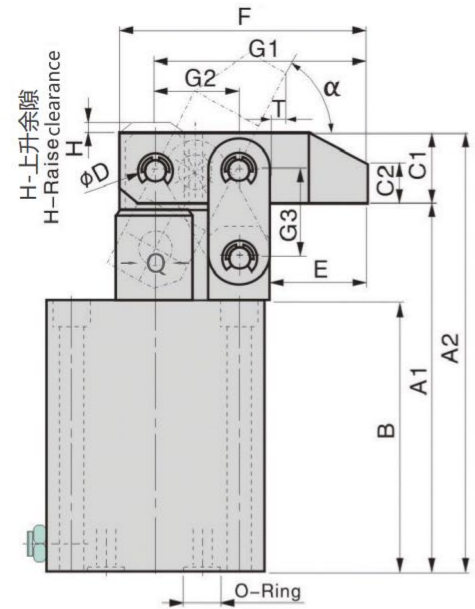

CHLC-MF

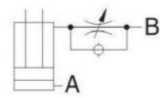

Ⓐ 夹持油孔 Clamping port Ⓑ 放松油孔 Unclamping port

法兰型 CHLC-FA

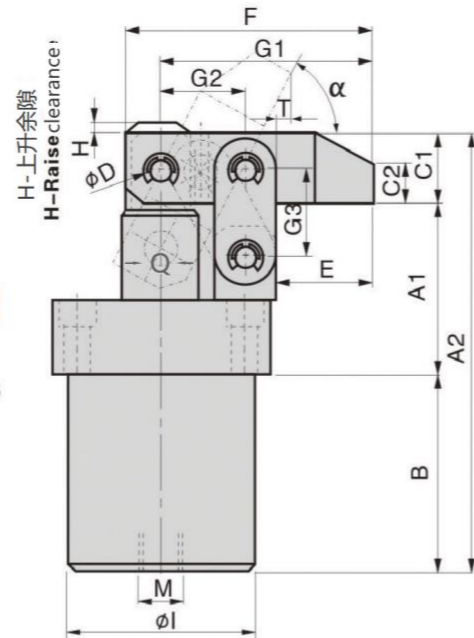

CHLC-FA

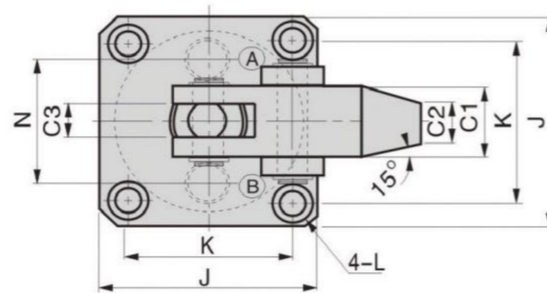
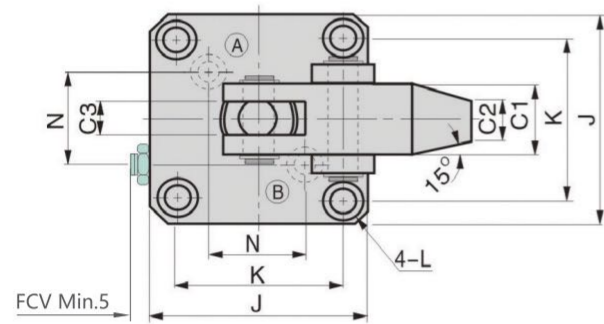

Unit:mm

MODEL	A1	A2	B	C1	C2	C3	ΦD	E	F	G1	G2	G3	H	ΦI	J	K	L	M	N	O-Ring	α	T	Q
CHLC-MF25	112	131	85	□19	11	9	Φ8	25	64	55	22	24	3	-	55	42	Φ6.8-Φ10.5 ×6.5D	-	19	P7	61°	4	Φ18
CHLC-MF32	115	134	88	□19	11	9	Φ8	25	64	55	22	24	3	-	57	44	Φ6.8-Φ10.5 ×6.5D	-	21	P7	52°	11	Φ20
CHLC-MF40	130	152	98	□22	13	10	Φ10	30	77	66	26	29	4	-	69	52	Φ9-Φ14 ×9D	-	23	P9	58°	7.5	Φ22.4
CHLC-MF50	145	170	108	□25	15	11	Φ12	35.5	90	77	30	33	4	-	75	58	Φ9-Φ14 ×9D	-	28	P9	61°	7.5	Φ28
CHLC-MF63	163	195	119	□32	19	15	Φ15	43	110	94	36	39	4	-	96	75	Φ11-Φ18 ×11D	-	35	P9	66°	2	Φ35.5
CHLC-FA25	49	131	63	□19	11	9	Φ8	25	64	55	22	24	3	Φ45	55	42	Φ6.8-Φ10.5 ×6.5D	PT1/4	25	-	61°	4	Φ18
CHLC-FA32	52	134	63	□19	11	9	Φ8	25	64	55	22	24	3	Φ50	57	44	Φ6.8-Φ10.5 ×6.5D	PT1/4	32	-	61°	5	Φ20
CHLC-FA40	57	152	73	□22	13	10	Φ10	30	77	66	26	29	4	Φ58	69	52	Φ9-Φ14 ×9D	PT1/4	40	-	61°	5.5	Φ22.4
CHLC-FA50	67	170	78	□25	15	11	Φ12	35.5	90	77	30	33	4	Φ68	75	58	Φ9-Φ14 ×9D	PT1/4	50	-	61°	7.5	Φ28
CHLC-FA63	74	196	90	□32	19	15	Φ15	43	110	94	36	39	4	Φ82	98	75	Φ11-Φ18 ×11D	PT1/4	63	-	66°	2	Φ35.5

法兰型油路板 CHLC-FAM

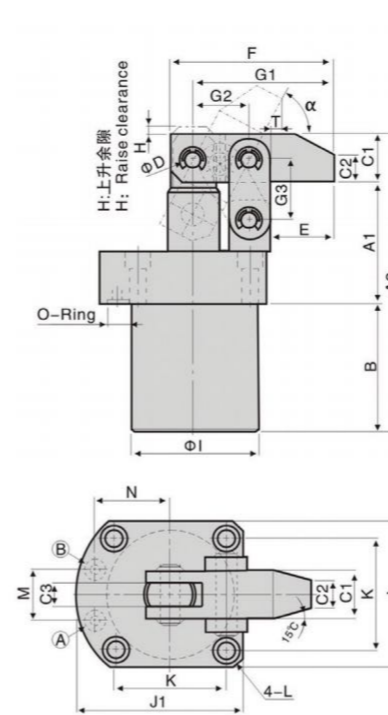

Ⓐ 夹持油孔 Clamping port  
Ⓑ 放松油孔 Unclamping port

法兰型附调速 CHLC-FAMT

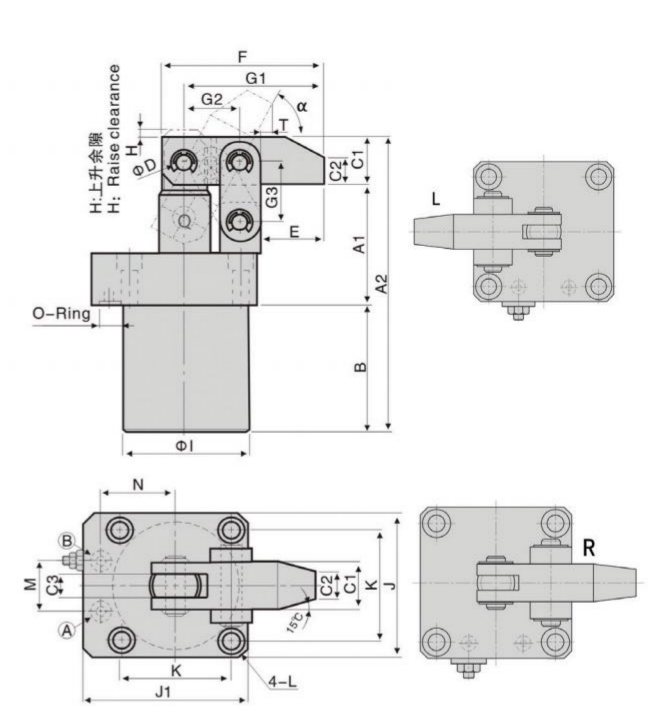

Unit:mm

MODEL	A1	A2	B	C1	C2	C3	ΦD	E	F	G1	G2	G3	H	ΦI	J	J1	K	L	M	N	O-Ring	α	T	Q
CHLC-FAM25	49	122	54	□19	11	9	Φ8	25	64	55	22	24	3	Φ45	55	64	42	Φ6.8-Φ10.5 ×6.5D	20	28	P6	61°	4	Φ18
CHLC-FAM32	52	131	60	□19	11	9	Φ8	25	64	55	22	24	3	Φ50	57	65.5	44	Φ6.8-Φ10.5 ×6.5D	22	29	P6	61°	5	Φ20
CHLC-FAM40	57	144	65	□22	13	10	Φ10	30	77	66	26	29	4	Φ58	69	79	52	Φ9-Φ13.5 ×9D	25	34.5	P9	61°	5.5	Φ22.4
CHLC-FAM50	67	162	70	□25	15	11	Φ12	35.5	90	77	30	33	4	Φ68	75	87	58	Φ9-Φ13.5 ×9D	30	39	P9	61°	7.5	Φ28
CHLC-FAM63	74	187	81	□32	19	15	Φ15	43	110	94	36	39	4	Φ82	98	114	75	Φ11-Φ18 ×11D	40	49.5	P9	66°	2	Φ35.5
CHLC-FAMT25	49	122	54	□19	11	9	Φ8	25	64	55	22	24	3	Φ45	55	64	42	Φ6.8-Φ10.5 ×6.5D	20	28	P6	61°	4	Φ18
CHLC-FAMT32	52	131	60	□19	11	9	Φ8	25	64	55	22	24	3	Φ50	57	65.5	44	Φ6.8-Φ10.5 ×6.5D	22	29	P6	61°	5	Φ20
CHLC-FAMT40	57	144	65	□22	13	10	Φ10	30	77	66	26	29	4	Φ58	69	79	52	Φ9-Φ13.5 ×9D	26	34.5	P9	61°	5.5	Φ22.4
CHLC-FAMT50	67	162	70	□25	15	11	Φ12	35.5	90	77	30	33	4	Φ68	75	87	58	Φ9-Φ13.5 ×9D	30	39	P9	61°	7.5	Φ28
CHLC-FAMT63	74	187	81	□32	19	15	Φ15	43	110	94	36	39	4	Φ82	98	114	75	Φ11-Φ18 ×11D	40	49.5	P9	66°	2	Φ35.5

# LHC01

## 杠杆式油压缸

### LHC01 HYDRAULIC LEVERAGE CLAMP



单动式 复动式

#### 产品特性

此系列产品有五种可供选择的缸径：Φ25,Φ32,Φ40,Φ50,Φ63。本产品使用了高性能的密封圈，避免了油缸的泄漏，且其寿命长。  
应用了杠杆原理，使工件容易夹紧，提高效率。缸体所用的材质是45钢，活塞材质是45#钢热处理，表面镀铬。缸体一体成型。

最大操作压力：70 kgf/cm<sup>2</sup>  
最小操作压力：20 kgf/cm<sup>2</sup>  
作动方式：单动式和复动式

#### FEATURES

Five available bore diameter:Φ25,Φ32,Φ40,Φ50,Φ63  
Use high-quality seal to avoid leakage and keep long operation.  
Lever principle design is applied on this hydraulic cylinder. Clamping work piece easily and improve efficiency.  
The material of the cylinder body and the piston is 45# steel, heat treatment,chrome plated.

Max.operating pressure: 70 kgf/cm<sup>2</sup>  
Man.operating pressure: 20 kgf/cm<sup>2</sup>  
Single acting and double acting

剖面图 Sectional view(复动型)

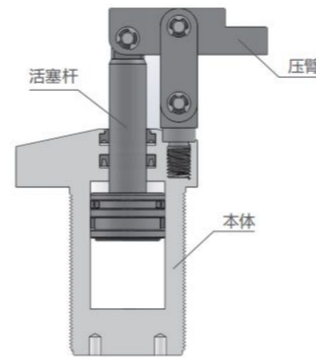

#### 注意事项

夹紧及放松作动速度需适当放缓。

#### NOTE

The speed of clamping and unclamping action needs to be slowed down appropriately.

#### 订购标示法 ORDERING INDICATION

##### 示例：LHC01D-40CRAW

LHC01	系列 Series	LHC01
D	作动方式 Acting type	D: 复动式 D: Double acting S: 单动式 S: Single acting
40	油缸内径 Hydraulic cylinder inside diameter	Φ25, Φ32, Φ40, Φ50, Φ63
C	空白：配管油路板共用 C: 油路板附调速	Blank: Containing oil board sharing C: Manifold with flow control
R	压臂安装方向 Lever direction	Blank: 空白 R: 右, L: 左
A	缸体一体成型	A: Integrated
W	W:缸体上三方具有压臂安装座孔	W: Clamping arm can be installed in three directions.

备注：一体成型的没有W型  
Note: An integrated can not be made W type.

压臂安装方向 Lever Direction

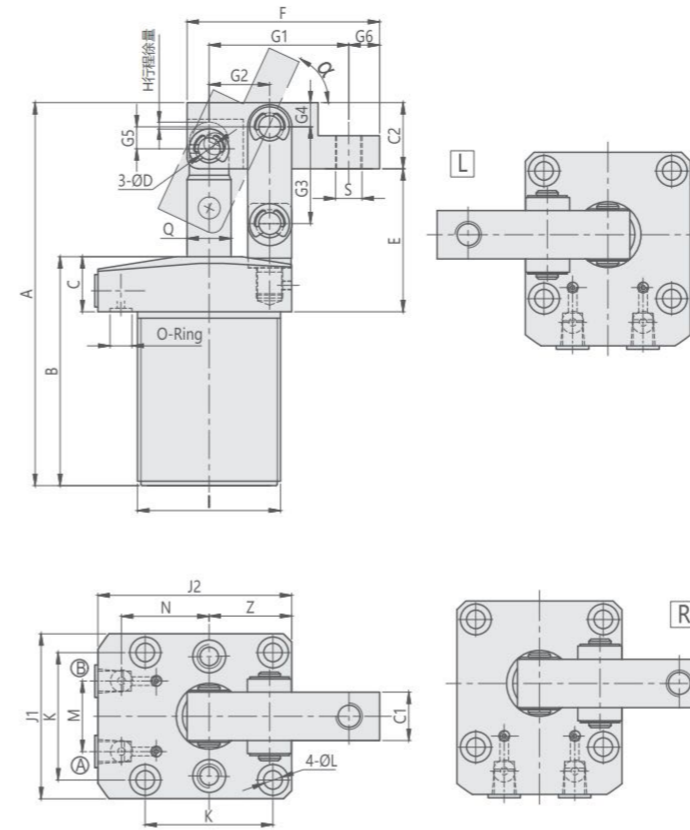

Ⓐ 夹持油孔 Clamping port  
Ⓑ 放松油孔 Unclamping port  
(单动型Ⓑ为排气孔)

MODEL	LHC01S-25	LHC01S-32	LHC01S-40	LHC01S-50	LHC01S-63
ITEM	LHC01D-25	LHC01D-32	LHC01D-40	LHC01D-50	LHC01D-63
A	128.5	149	157	174	179
B	86.5	97	97	104	105
C	25	25	25	25	25
C1	16	18	20	22	22
C2	17	20	25	30	30
D	Φ6	Φ6	Φ8	Φ10	Φ10
E	50	57	60	65	69
F	55	68	75	87.5	98
G1	41	52	56	63.5	74
G2	18	22	24	27.5	32
G3	26	33	33	44	48
G4	6.5	8	13	11	11
G5	4.5	5	4	10	10
G6	7	8	10	14	14
H	2	3	3	3	3
I	M40x1.5	M50x1.5	M55x1.5	M65x1.5	M80x1.5
J1	50	60	65	75	90
J2	60	70	75	88	108
K	□37	□45	□50	□58	□70
L	Φ5.5-Φ9 x5.5D	Φ6.5-Φ11 x6.5D	Φ6.5-Φ11 x6.5D	Φ8.5-Φ14 x9D	Φ8.5-Φ14 x9D
配管式油口 PORT WITH LINE TYPE	2-PT1/8	2-PT1/8	2-PT1/8	2-PT1/8	2-PT1/8
M	23	23	26	32	35
N	26	30.5	33	38	48
Z	25	30	32.5	37.5	45
S	M6	M8	M8	M12	M12
α	75°	75°	75°	65°	60°
O型圈 O-Ring	P7	P7	P7	P7	P7
Q	Φ14	Φ16	Φ16	Φ20	Φ20

#### 规格参数表 SPECIFICATIONS

型号	理论夹持力 (70 kgf/cm <sup>2</sup> )	夹紧行程	总行程	推出容积	拉入容积	推出受压面积	拉入受压面积	使用温度范围	使用流体
MODEL	CLAMPING FORCE AT 70 kgf/cm <sup>2</sup> (kgf)	CLAMPING STROKE (mm)	TOTAL STROKE(mm)	CYLINDER CAPACITY CLAMP(cm <sup>3</sup> )	CYLINDER CAPACITY UNCLAMP(cm <sup>3</sup> )	EFF.PISTON AREA CLAMP(cm <sup>2</sup> )	EFF.PISTON AREA UNCLAMP(cm <sup>2</sup> )	RANGE OF TEMPERATURE(°C)	USABLE FLUID
LHC01S-25	158	22	24	11.78	-	4.91	-	-10~+70°C	相当于ISO黏度等级的ISO-VG-32一般液压油 Recommended: ISO-VG-32 hydraulic oil equivalent to ISO viscosity grade
LHC01D-25	268	22	24	11.78	8.09	4.91	3.37	-10~+70°C	
LHC01S-32	243	28	31	24.92	-	8.04	-	-10~+70°C	
LHC01D-32	412	28	31	24.92	18.69	8.04	6.03	-10~+70°C	
LHC01S-40	388	30	33	41.45	-	12.56	-	-10~+70°C	
LHC01D-40	659	30	33	41.45	34.82	12.56	10.55	-10~+70°C	
LHC01S-50	618	30	33	64.78	-	19.63	-	-10~+70°C	
LHC01D-50	1049	30	33	64.78	54.42	19.63	16.49	-10~+70°C	
LHC01S-63	980	30	33	102.83	-	31.16	-	-10~+70°C	
LHC01D-63	1662	30	33	102.83	92.47	31.16	28.02	-10~+70°C	

# YCGF

## 单动外螺纹杠杆式油压缸

## YCGF SINGLE-ACTION EXTERNAL THREAD LEVERAGE CLAMP



### 产品特性

此系列产品配件采用新改革设计，与传统产品比较夹紧力提高了。产品支撑点部位与缸体采用一体化结构，使体积更加扎实，提高了产品强度。产品采用专用防尘设计，提高了防尘和密封性，实现了高密封性。产品法兰下部采用缩小型和外螺纹设计，最适合夹具要求的紧凑型轻量化。

最大操作压力：70kgf/cm<sup>2</sup>  
最小操作压力：25kgf/cm<sup>2</sup>

### 注意事项

夹紧及放松动作速度需放缓。  
可接受定制，欢迎与本公司洽询。

### FEATURES

The accessories of the YCGF series are optimally designed and the clamping capacity has increased immensely compared to the traditional products. The cylinder and its supporting point use an integrated structure to create a more compact-sized product with enhanced strength. With its special dust-proof design, this product has improved its sealing performance and protects against any particles or debris while in use. The lower flange adopts a volume-compressed and external threaded design, specifically to operate efficiently under the fixtures's lightweight requirements.

Max. operating pressure: 70kgf/cm<sup>2</sup>  
Min. operating pressure: 25kgf/cm<sup>2</sup>

### NOTE

The action and speed of clamping / unclamping needs to be slowed down appropriately.  
Customization is available upon request, please contact us for more info.

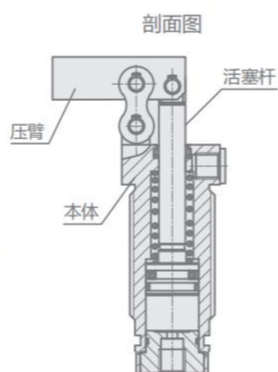

### 订购标示法 ORDERING INDICATION

#### 示例: YCGF-32

YCGF	系列 Series	YCGF
32	外螺纹尺寸 External thread size	32: M32*1.5 40: M40*1.5

### 规格参数表 SPECIFICATIONS

型号	理论夹持力 (70 kgf/cm <sup>2</sup> )	夹紧行程	总行程	推出容积	推出受压面积	弹簧阻力	使用温度范围	使用流体
MODEL	CLAMPING FORCE AT 70 kgf/cm <sup>2</sup> (kgf)	CLAMPING STROKE (mm)	TOTAL STROKE(mm)	CYLINDER CAPACITY CLAMP(cm <sup>3</sup> )	EFF.PISTON AREA CLAMP(cm <sup>2</sup> )	SPRING FORCE(kgf)	RANGE OF TEMPERATURE(°C)	USABLE FLUID
YCGF-32	130	13.5	15	4.24	3.14	22	-10~+70	相当于ISO粘度等级的ISO-VG-32 一般液压油 Recommended: ISO-VG-32 hydraulic oil equivalent to ISO viscosity grade
YCGF-40	205	16	19	7.84	4.90	28.5	-10~+70	

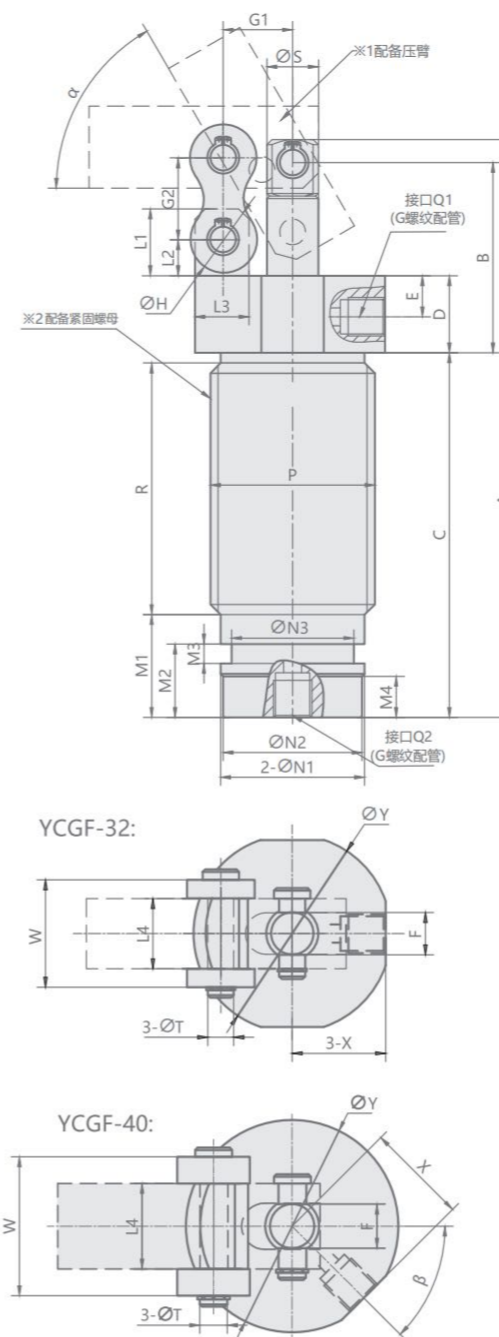

### 安装部位加工尺寸

#### YCGF-32:

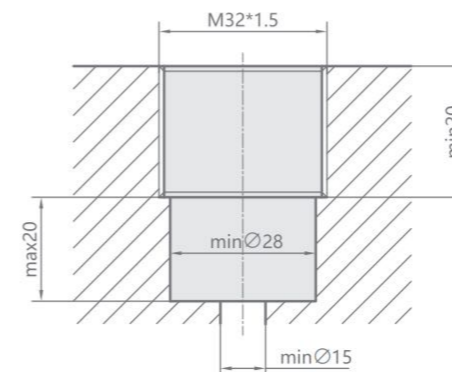

#### YCGF-40:

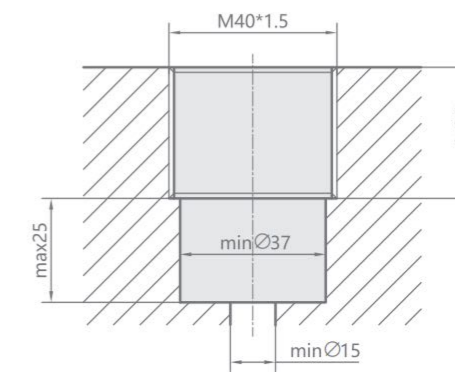

### 注意事项:

- ※1. 本产品未附带压臂，请客户参考表格尺寸自行配备。
- ※2. 客户需参考外螺纹安装尺寸配备紧固螺母。

Unit:mm

MODEL	YCGF-32	YCGF-40
A	112.5	142
B	37	46
C	71	89
D	15	16
E	8	8
F	8 <sup>-0.05</sup> <sub>-0.1</sub>	9.8 <sup>-0.05</sup> <sub>-0.1</sub>
G1	13.5	17
G2	15.9	19
H	13	15.7
L1	13	18
L2	7	10
L3	10.5	12
L4	13.5	18.5
M1	20	25
M2	14.3	13.3
M3	3.8	3.8
M4	8	6
N1	28	37
N2	27	35.5
N3	23.8	34
P	M32*1.5	M40*1.5
Q1	G1/8	G1/8
Q2	G1/8	G1/8
S	10	12
T	5 <sup>0</sup> <sub>-0.02</sub>	6 <sup>0</sup> <sub>-0.02</sub>
R	49	57
W	21	30.5
X	18	22
Y	38	46
α	60°	55°
β	0°	45°
行程	15	19

# CCLT

## 紧凑型单动 杠杆式油压缸

## CCLT SINGLE ACTING LEVERAGE CLAMP



### 产品特性

此系列产品配件采用新改革设计,与传统产品比较夹紧能力提高了。产品支撑点部位与缸体采用一体化结构,使体积更加扎实,提高了产品强度。产品采用了专用防尘设计,提高了防尘和密封性,实现了高密封性。产品法兰下部采用缩小型设计,最适合夹具要求的紧凑性和轻量化。

最大操作压力: 70kgf/cm<sup>2</sup>  
最小操作压力: 25kgf/cm<sup>2</sup>

### FEATURES

Product with optimal design,so the clamping capacity is better than others clamps.Product with the integrated structure on support site and cylinder body,so made product will be more impact,and strength will be improved.Product with special dustproof design,to make sure a high sealing performance.Product with lower flange design,more suitable for compact and light fixture.

Max.operating pressure: 70kgf/cm<sup>2</sup>  
Min.operating pressure: 25kgf/cm<sup>2</sup>

剖面图 Sectional view(单动型)

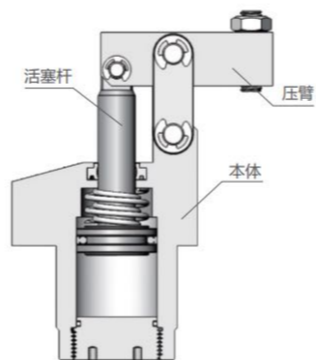

### 注意事项

夹紧及放松动作速度需适当放缓。可接受订制, 欢迎与本公司洽询。

### NOTE

The speed of clamping and unclamping action needs to be slowed down appropriately.Orders with customized request are available, welcome to contact us.

### 订购标示法 ORDERING INDICATION

#### 示例: CCLT-02L

CCLT	系列 Series	CCLT	
02	02/04/06/10/16/25		
L	压臂安装方向 Lever Direction	空白:标准 Blank:Standard	L:左 R:右 L:Left R:Right

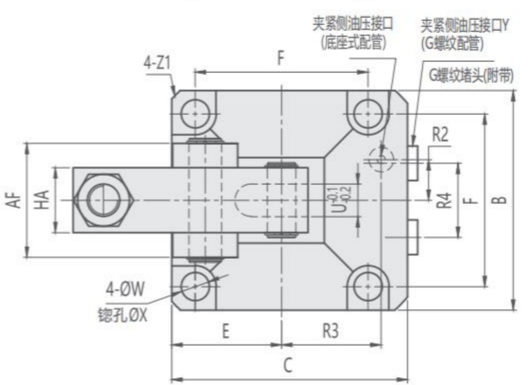
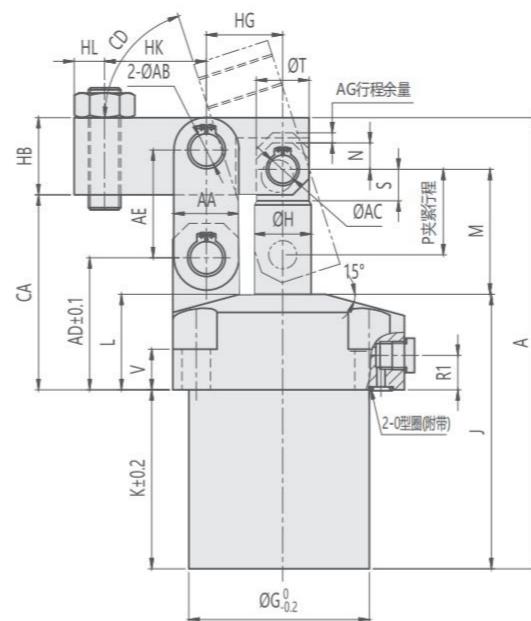

压臂安装方向 Lever Direction

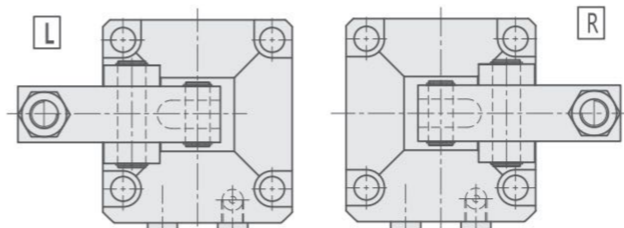

Unit:mm

MODEL ITEM	CCLT -02	CCLT -04	CCLT -06	CCLT -10	CCLT -16	CCLT -25
A	101	114	132.5	147	180	214
B	45	50	57	70	86	108
C	55	60	66	82	96	120
E	22.5	25	28.5	35	43	54
F	35	40	46	56	68	88
G	39	47	53	63	78	100
H	12	14	14	16	22.4	28
J	64	72	84	90	109	127
K	37.5	45.5	55.5	54	69	80
L	26.5	26.5	28.5	36	40	47
M	28.5	32	34.5	40	49	61.5
N	5	6	6	8	11	13
P	17.5	20.5	23	26.5	33	42
R1	12.5	12.5	12.5	14	14	21
R2	11	12	14	18	22.5	25
R3	25	28	30.5	36	42	57
R4	20	22	26	30	38	50
S	6.5	7	7	9	10.8	14.5
T	10	12	12	14	20	26
U	6	6	8	10	11	16
V	18	17	17	20	20	20
W	5.5	5.5	6.8	9	11	14
X	10	10	12	15	18.5	20
Y	G1/8	G1/8	G1/8	G1/4	G1/4	G3/8
Z1	C1.5	C2.5	C2.5	C3	C3.5	C5.5
O型圈	P7	P7	P7	P8	P8	P10
AA	11	13	15	19	25	32
AB	6 <sup>+0.012</sup> <sub>0</sub>	6 <sup>+0.012</sup> <sub>0</sub>	8 <sup>+0.015</sup> <sub>0</sub>	10 <sup>+0.015</sup> <sub>0</sub>	14 <sup>+0.018</sup> <sub>0</sub>	16 <sup>+0.018</sup> <sub>0</sub>
AC	6 <sup>+0.012</sup> <sub>0</sub>	6 <sup>+0.012</sup> <sub>0</sub>	6 <sup>+0.012</sup> <sub>0</sub>	8 <sup>+0.015</sup> <sub>0</sub>	12 <sup>+0.018</sup> <sub>0</sub>	14 <sup>+0.018</sup> <sub>0</sub>
AD	34	36	39	48	54.5	65
AE	24	26	30	35.5	44	53
AF	21	21	28	37	46	56
AG	3	3	3	3	3	3
CA	49.5	52.5	57	68	80	96
CD	约69°	约71°	约70°	约70°	约69°	约72°
HA	12	12	16	19	22	32
HB	14	16	20	25	31	38
HG	16.5	18.5	21	24.5	30.5	37.5
HK	20	23.5	29	32	39	50
HL	6	6	8	10	11	15

### 规格参数表 SPECIFICATIONS

型号	理论夹持力 (70 kgf/cm <sup>2</sup> )	夹紧行程	总行程	推出容积	推出受压面积	使用温度范围	弹簧阻抗	使用流体
MODEL	CLAMPING FORCE AT 70 kgf/cm <sup>2</sup> (kgf)	CLAMPING STROKE (mm)	TOTAL STROKE(mm)	CYLINDER CAPACITY CLAMP(cm <sup>3</sup> )	EFFEPISTON AREA CLAMP(cm <sup>2</sup> )	RANGE OF TEMPERATURE(°C)	SPRING FORCE (kgf)	USABLE FLUID
CCLT-02	245	17.5	20.5	10	4.9	0~+70°C	25	相当于ISO黏度等级的ISO-VG-32一般液压油 Recommended: ISO-VG-32 hydraulic oil equivalent to ISO viscosity grade
CCLT-04	326.5	20.5	23.5	16.7	7.1	0~+70°C	40	
CCLT-06	408	23	26	25	9.6	0~+70°C	63	
CCLT-10	694	26.5	29.5	44.8	15.2	0~+70°C	81	
CCLT-16	1133	33	36	88.6	24.6	0~+70°C	152	
CCLT-25	1745	42	45	173.3	38.5	0~+70°C	158	

# CLM

## 单动杠杆式油压缸

### CLM SINGLE ACTING HYDRAULIC LEVERAGE CLAMP

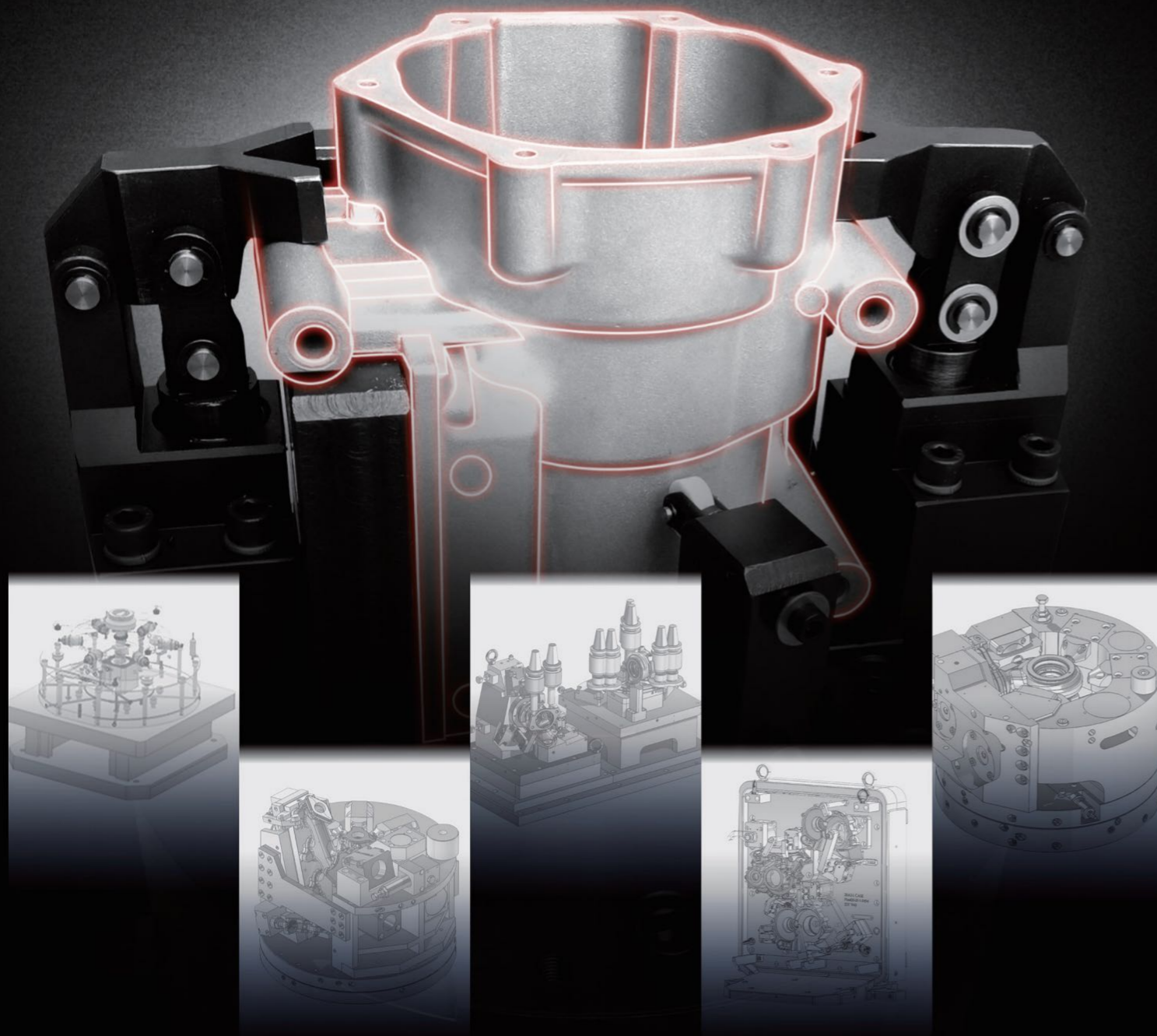

#### 产品特性

1. 此系列产品内部搭配弹簧,实现单动油压作动,简化回路设计。
2. 采用特殊设计,提高防尘密封性,实现产品高密封性。
3. 可直接安装速度控制阀,可调节压臂下压速度。

最大操作压力: 70kgf/cm<sup>2</sup>  
 最小操作压力: 25kgf/cm<sup>2</sup>

#### FEATURES

1. This series of products are internally equipped with springs to achieve single-action hydraulic actuation, simplifying the circuit design.
2. It adopts a special design to enhance dust-proof sealing and achieve high sealing performance of the product.
3. The speed control valve can be directly installed and the downward pressing speed of the clamping arm can be adjusted.

Max.operating pressure:70kgf/cm<sup>2</sup>  
 Min.operating pressure:25kgf/cm<sup>2</sup>

#### 订购标示法 ORDERING INDICATION

示例: CLM-048GL

CLM	系列 Series	CLM:铝合金本体 CLJ:合金钢本体	CLM: Aluminum alloy body CLJ: Alloy steel body
048	主体尺寸 Body size	036=∅36mm 040=∅40mm 048=∅48mm 055=∅55mm	065=∅65mm 075=∅75mm 090=∅90mm 105=∅105mm
G	配管方式 Port type	G:油路板式 S:配管式	G: Manifold type S: Line type
L	压臂方向 Lever direction	空白:中央 L:左向 R:右向	Blank: Center L: Left R: Right

### 外形尺寸

### 安装部位加工尺寸

### 外形尺寸及安装部位加工尺寸表

Unit:mm

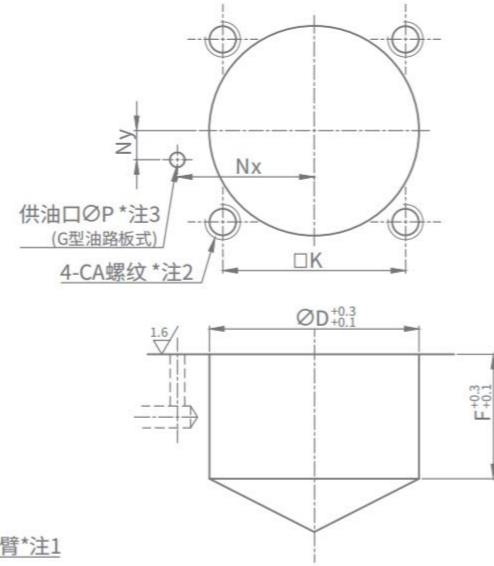
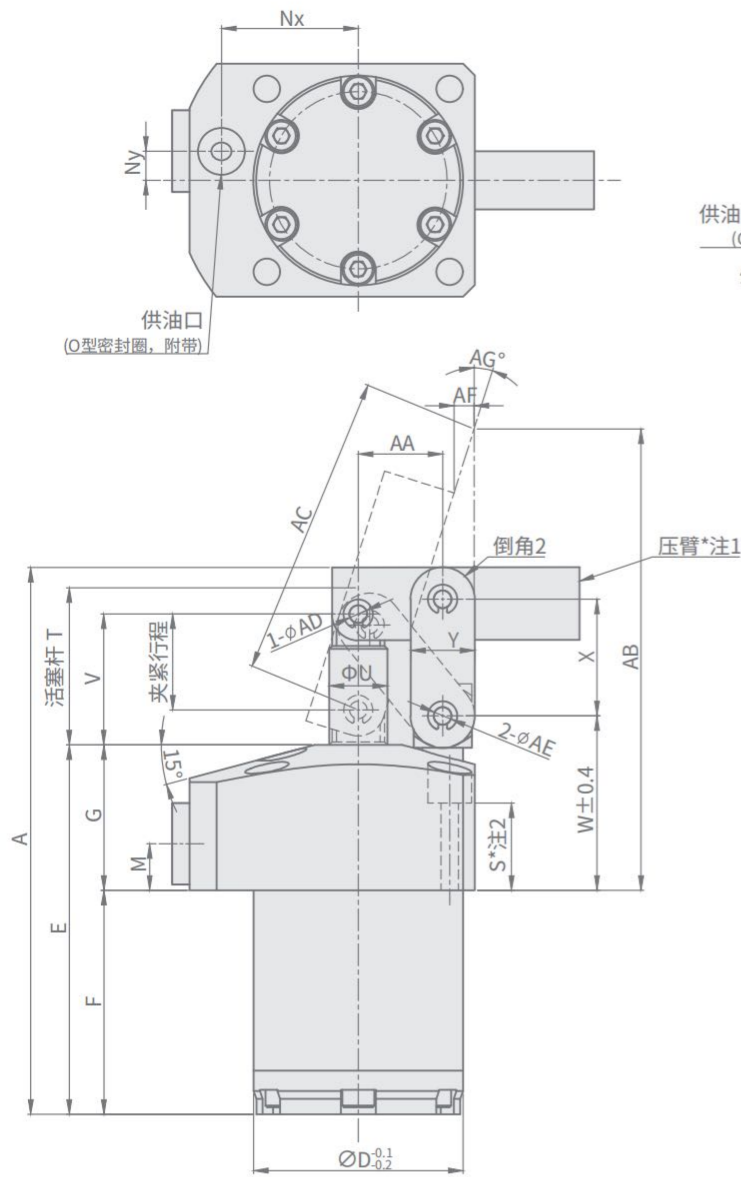

\*注1、此类产品出货时，不附压臂，若客户欲自制压臂，请参阅我司CLKA规格的压臂尺寸。  
\*注2、此类产品未附带安装螺栓，请客户根据安装高度，并参照S尺寸自行配备。  
\*注3、此供油口仅为油路板式连接的情况。

### 配管方式G型油路板式

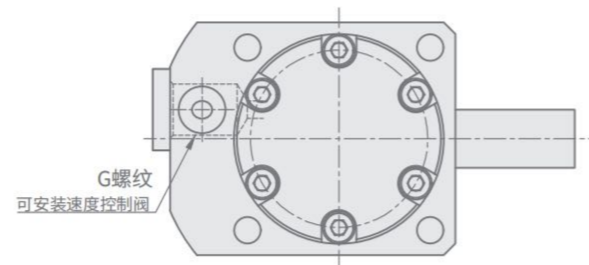

### S型配管式

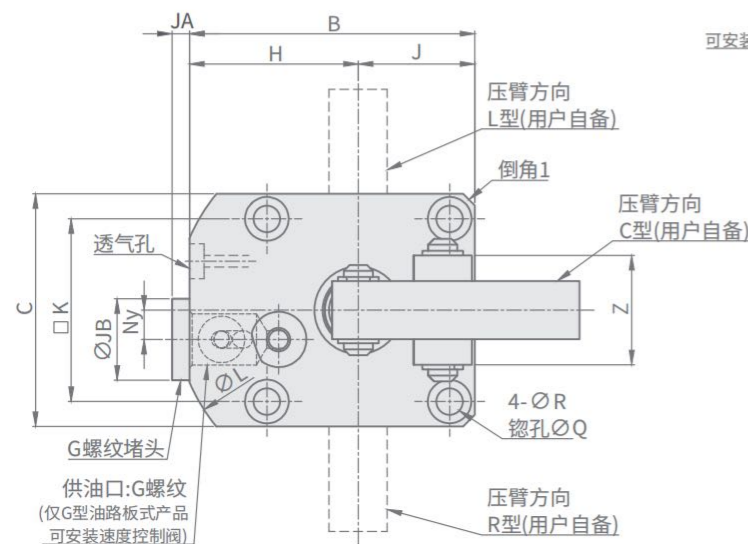
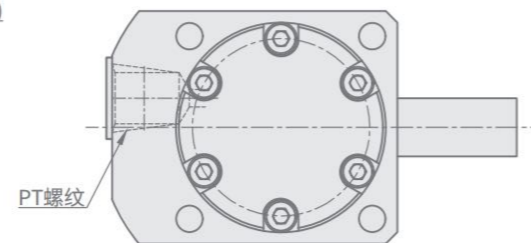

型号	CLM036 CLJ036	CLM040 CLJ040	CLM048 CLJ048	CLM055 CLJ055	CLM065 CLJ065	CLM075 CLJ075	CLM090 CLJ090	CLM105 CLJ105
全行程	18.5	20.5	23.5	26	29.5	35	41	49
夹紧行程	16	17.5	20.5	23	26.5	32	38	46
行程余量	2.5	3	3	3	3	3	3	3
A	94	103.5	114	132.5	147	175	207	243
B	49	54	61	69	81	94.5	109.5	127
C	40	45	51	60	70	85	100	120
D	36	40	48	55	65	75	90	105
E	63.5	70	75	87	93	108	128	149
F	38.5	45	47	59	63	71	88	99
G	25	25	28	28	30	37	40	50
H	29	31.5	35.5	39	46	52	59.5	67
J	20	22.5	25.5	30	35	42.5	50	60
K	31.4	34	40	47	55	63	75	88
L	63	68	73	80	94	106	126	147
M	11	11	12	12	13	16	16	17
Nx	23.5	26	30	33.5	39.5	45	52.5	60
Ny	5	5	0	0	0	0	0	0
P	3	3	3	3	5	5	5	5
Q	75	9.5	9.5	11	11	14	17.5	20
R	4.5	5.5	5.5	6.8	6.8	9	11	14
S	18	15.5	17.5	15	15.5	19.5	19	24.5
T	27	30.5	35	37.5	45	55	64.5	77
U	10	12	14	16	18	22	28	35.5
V	22.5	25	29	31.5	37	45	52	62
W	30	30.5	34.5	35.5	39	48	52.5	64
X	20	22	26	30	35.5	43.5	52.5	64
Y	11	13	13	16	19	25	28	32
Z	19	21	21	28	37	40	49	64
倒角1	C2	C3	C3	Ø80	Ø94	Ø106	Ø126	Ø147
倒角2	C2.5	C3	C3	C3	C5	C5	C6	C6
AA	14.5	16	18.5	21	24.5	30	36	44
AB	74.3	77.7	92.4	101.9	111.4	130.8	146.5	173.6
AC	47.3	50.2	61.2	71.7	78.7	90.8	104.6	122.5
AD	5	6	6	6	8	10	12	15
AE	5	6	6	8	10	12	15	18
AF	2.9	2.7	4.3	4.7	4.3	4.5	5	4.1
AG	19.6	20.2	18.9	19.9	20.5	21.4	22.4	23.1
CA	M4X0.7	M5X0.8	M5X0.8	M6	M6	M8	M10	M12
JA	3.5	3.5	3.5	3.5	4.5	4.5	4.5	4.5
JB	14	14	14	14	19	19	22	22
JB供油口G型油路板式G螺纹 推荐配管内径	G1/8 Ø6	G1/8 Ø6	G1/8 Ø6	G1/8 Ø6	G1/4 Ø8	G1/4 Ø8	G3/8 Ø12	G3/8 Ø12
O形密封圈(G型油路板式) 供油口S型配管式PT螺纹	1BP5 PT1/8	1BP5 PT1/8	1BP5 PT1/8	1BP5 PT1/8	1BP7 PT1/4	1BP7 PT1/4	1BP7 PT3/8	1BP7 PT3/8

# CCG

## 微型杠杆油压缸

# CCG MINIATURE LEVERAGE CLAMP



### 产品特性

此系列产品具有高夹紧力和最小空间的要求。

最大操作压力: 200kgf/cm<sup>2</sup>  
最小操作压力: 30kgf/cm<sup>2</sup>

### FEATURES

This series clamp stand out for high clamping forces and minimum space requirements.

Max.operating pressure:200kgf/cm<sup>2</sup>  
Min.operating pressure:30kgf/cm<sup>2</sup>

### 注意事项

可根据客户要求生产不同的压臂

### NOTE

Different clamping arm can be produced according to customer requirements.

### 订购标示法 ORDERING INDICATION

示例: CCG6-200CD

CCG	系列 Series	CCG
6	活塞杆径 Rod Diameter(mm)	6:∅D=6mm 8:∅D=8mm (∅D表示油缸活塞杆尺寸) (∅D represents the cylinder rod diameter)
200CD		

### 规格参数表 SPECIFICATIONS

型号	理论夹持力 (200 kgf/cm <sup>2</sup> )	夹紧行程	行程余量	总行程	推出容积	拉入容积	推出受压面积	拉入受压面积	使用温度范围
MODEL	CLAMPING FORCE AT 200kgf/cm <sup>2</sup> (kgf)	CLAMPING STROKE(mm)	EXTRA STROKE(mm)	TOTAL STROKE(mm)	CYLINDER CAPACITY UNCLAMP(cm <sup>3</sup> )	CYLINDER CAPACITY CLAMP(cm <sup>3</sup> )	EFF.PISTON AREA UNCLAMP(cm <sup>2</sup> )	EFF.PISTON AREA CLAMP(cm <sup>2</sup> )	RANGE OF TEMPERATURE(°C)
CCG6-200CD	93	9.3	1.5	10.8	0.6	0.9	0.51	0.79	0~+70°C
CCG8-200CD	146	12	2	14	1.5	2.2	1.04	1.54	0~+70°C

### 外形尺寸图 External Dimensions

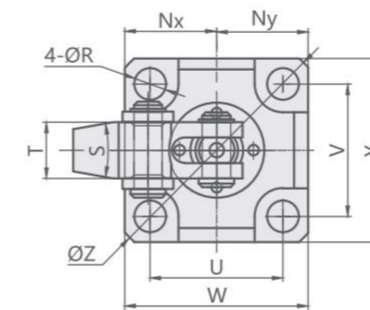
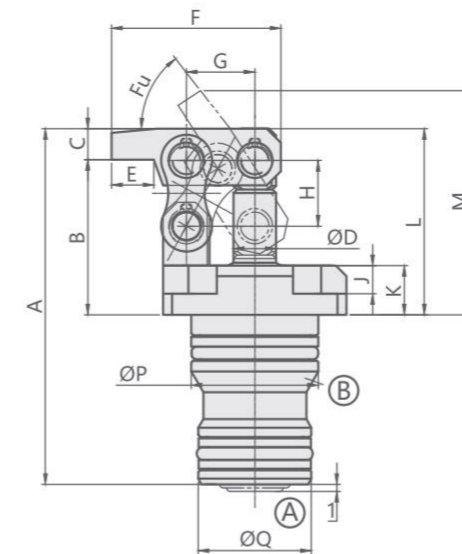

- (A) 夹持油孔 Clamping port
- (B) 放松油孔 Unclamping port

### 安装部位加工尺寸 Machining Dimensions of Mounting Area

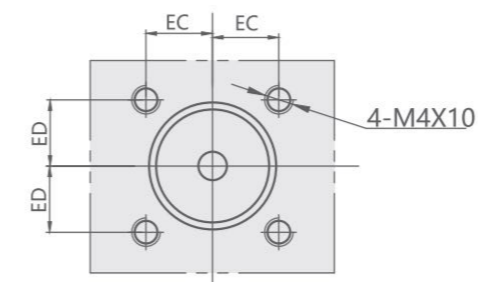
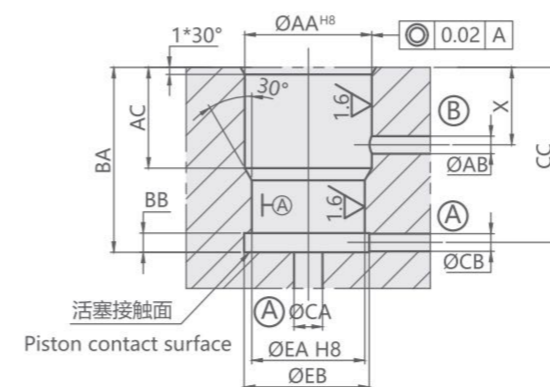

Unit:mm

型号 Model item	CCG6-200CD	CCG8-200CD
A	50.4	65.9
B	22	27.4
C	4.4	6.5
D	6	8
E	6	8
F	24	35
Fu	52°	59°
G	9.7	12.3
H	9.3	12
J	4	4
K	7	8
L	26.4	33.9
M	31.8	43.8
Nx	13	16.5
Ny	13	15.5
P	18	26
Q	16	23
R	4.5	5
S	20°	30°
T	8	11.5
U	18.8	24
V	18.8	25
W	26	32
Y	26	33
Z	35	42
X	11±1	13±1
AA	18	26
AB	2.5	4~6
AC	14.3	16.5
BA	25 <sup>+0.3</sup> <sub>+0.2</sub>	33 <sup>+0.3</sup> <sub>+0.2</sub>
BB	1.5	5
CA	4	5~10
CB	—	4~6
CC	—	30.5
EA	16	23
EB	16.5	23.5
EC	9.4	12
ED	9.4	12.5

# CCLV

## 高压单动小巧型杠杆式油压缸

### CCLV HYDRAULIC SINGLE ACTION LEVERAGE CLAMP (HIGH PRESSURE)



#### 产品特性

此系列油缸产品配件采用优化设计,外型小巧,采用高压设计,与传统产品比较夹持能力提高了,产品支撑点部位与缸体采用一体化结构,使夹持更加扎实,提高了产品强度。产品采用了专用防尘设计,提高了防尘和密封性,实现了高密封性。

最大操作压力: 350kgf/cm<sup>2</sup>  
 最小操作压力: 35kgf/cm<sup>2</sup>  
 动作方式: 单动式

#### FEATURES

This series of the CCLV series are optimally design, with compact appearance and high pressure design which improves the clamping capacity compared with traditional products. The cylinder and its supporting point use an integrated structure to create a more compact-sized product with enhanced strength. With its special dust-proof design, this product has improved its sealing performance and protects against any particles or debris while in use.

Max.operating pressure:350kgf/cm<sup>2</sup>  
 Min.operating pressure:35kgf/cm<sup>2</sup>  
 Single acting

剖面图 Sectional view

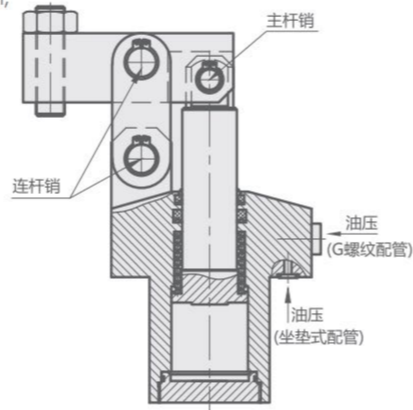

#### 注意事项

夹紧及放松动作速度需适当放缓。可接受定制, 欢迎与本公司洽询。

#### NOTE

The action and the speed of clamping / unclamping needs to be slowed down appropriately. Customization is available upon request, please contact us for more info.

#### 订购标示法 ORDERING INDICATION

示例: CCLV06-FN

CCLV	系列 Series	CCLV
06	06/10/16/25	
F	压臂安装方向 Lever direction	F: 标准 Blank: Standard R: 右 R: Right L: 左 L: left
N	小巧型	N: Mini type

#### 外形尺寸图 External Dimensions

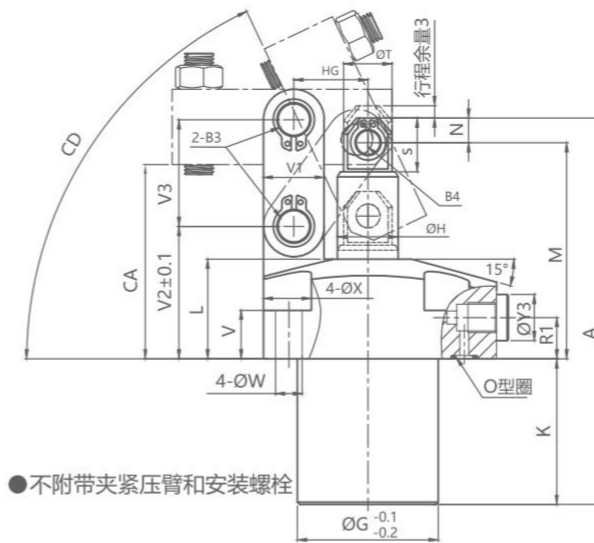

●不附带夹紧压臂和安装螺栓

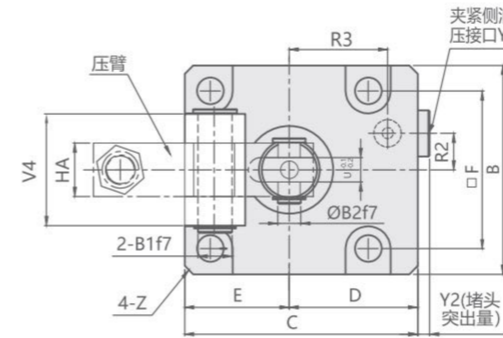

#### 压臂安装方向

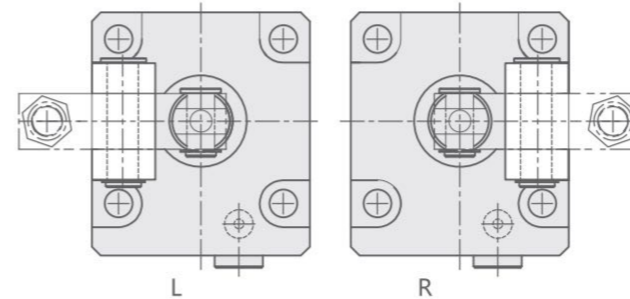

#### 外形尺寸 External Dimensions

Unit:mm

型号	CCLV06-□N	CCLV10-□N	CCLV16-□N	CCLV25-□N
A	115	134	160	190.5
B	60	70	86	108
C	69	77	96	110
D	39	42	53	56
E	30	35	43	54
F	47	54	65	85
∅G	44	48	58	66
∅H	16	20	25	30
K	43.5	53	60	69
L	32	33.5	41	47
M	65.5	73	89	108.5
N	6	8	11	13
R1	15	15	17	21
R2	11.5	13	15	20
R3	30	33	40	43
S	13	17	21.8	27.5
∅T	12	15	20	26
U(对边宽)	8	10	11	16
V	17	17	20	21
V1	15	19	25	32
V2	41.5	45	54.5	65
V3	30	35.5	44	53
V4	28	37	46	56
∅W	6.8	9	11	14
∅X	12	15	18.5	20.5
Y1	G1/8	G1/8	G1/4	G1/4
Y2	3.8	3.8	4.8	4.8
Y3	14	14	19	19
Z	C2.5	C3	C3.5	C5.5
∅B1	8 <sup>-0.013</sup> <sub>-0.028</sub>	10 <sup>-0.013</sup> <sub>-0.028</sub>	14 <sup>-0.016</sup> <sub>-0.034</sub>	16 <sup>-0.016</sup> <sub>-0.034</sub>
∅B2	6 <sup>-0.010</sup> <sub>-0.022</sub>	8 <sup>-0.013</sup> <sub>-0.028</sub>	12 <sup>-0.016</sup> <sub>-0.034</sub>	14 <sup>-0.016</sup> <sub>-0.034</sub>
B3(卡环)	STW-8	STW-10	STW-14	STW-16
B4(卡环)	STW-6	STW-8	STW-12	STW-14
CA	59.5	65	80	96
CD	约70°	约70°	约69°	约72°
HA	16	19	22	32
HG	21	24.5	30.5	37.5
O型圈(Hs90)	P9	P9	P9	P9

型号	油缸能力(油压为35MPa时)	杆径	油缸面积(夹紧)	全行程	夹紧行程	最大流量	油缸容量	使用油压范围	使用环境温度	使用流体
MODEL	HYDRAULIC CYLINDER CAPACITY AT 35MPa(kN)	ROD DIAMETER(mm)	HYDRAULIC CYLINDER AREA WHEN CLAMPING (cm <sup>2</sup> )	TOTAL STROKE (mm)	CLAMPING STROKE (mm)	MAX. FLOW RATE (cm <sup>3</sup> )	CYLINDER CAPACITY (cm <sup>3</sup> )	RANGE OF PRESSURE(MPa)	RANGE OF TEMPERATURE(°C)	USABLE FLUID
CCLV06-□N	6.8	16	2.0	26	23	0.54	5.2	3.5 ~ 35MPa	0 ~ 70°C	相当于ISO粘度等级的ISO-VG-32一般液压油 Recommended ISO-VG-32 hydraulic oil equivalent to ISO viscosity grade
CCLV10-□N	10.5	20	3.1	29.5	26.5	1.00	9.3	3.5 ~ 35MPa	0 ~ 70°C	
CCLV16-□N	16.7	25	4.9	36	33	1.93	17.7	3.5 ~ 35MPa	0 ~ 70°C	
CCLV25-□N	24.0	30	7.1	45	42	3.55	31.8	3.5 ~ 35MPa	0 ~ 70°C	

# CTMA

复动杠杆油压缸



## CTMA HYDRAULIC DOUBLE ACTION LEVERAGE CLAMP (HIGH PRESSURE)

### 产品特性

优异的防止冷却液侵入结构。即使对高压冷却液也具备有很高的密封性能，通过使用高性能的耐腐蚀防尘材料，即使长期使用于冷却液中也不会降低密封性能，可以直接安装速度控制阀。Model CZT(由用户自行购买),有3种压板夹紧方向可选。

最大操作压力: 350kgf/cm<sup>2</sup>  
最小操作压力: 35kgf/cm<sup>2</sup>

### FEATURES

Excellent Coolant Resistance our exclusive dust seal is designed to protect against high pressure coolant. It also has high durability against chlorine-based Coolant by using a sealing material with excellent chemical resistance. Able to attach speed control valve directly. Speed control valve(CZT) is sold separately. Three clamping directions are available.

Max.operating pressure:350kgf/cm<sup>2</sup>  
Min.operating pressure:35kgf/cm<sup>2</sup>

### 注意事项

夹紧及放松动作速度需适当放缓

### NOTE

The action and the speed of clamping/unclamping needs to be slowed down appropriately.

### 订购标示法 ORDERING INDICATION

示例: CTMA-025CR

CTMA	系列 Series	CTMA
025	主体尺寸 Body size	025: $\phi D=33\text{mm}$ 100: $\phi D=48\text{mm}$ $\phi D$ 表示本体油缸外径尺寸 040: $\phi D=36\text{mm}$ 160: $\phi D=60\text{mm}$ Outer diameter ( $\phi D$ ) of the cylinder 060: $\phi D=43\text{mm}$ 250: $\phi D=70\text{mm}$
C	型式 Type	B: 外配管型(G螺纹)    B: G Thread Piping Option(No Gasket Port) C: 板式连接型(附带G螺纹堵头)    C: Gasket Option(With G Thread Plug)
R	压臂安装方向 Lever direction	L:左    空白:中央    R:右 L:Left    Blank:Center    R:Right

注: 速度控制阀(CZT)由用户另行购买 Note: Speed control valve(CZT) is sold separately.

### 规格参数表 SPECIFICATIONS

型号	理论夹持力 (350kgf/cm <sup>2</sup> )	夹紧行程	行程余量	总行程	推出容积	拉入容积	推出受压面积	拉入受压面积	使用温度范围
MODEL	CLAMPING FORCE AT 350kgf/cm <sup>2</sup> (kgf)	CLAMPING STROKE(mm)	EXTRA STROKE(mm)	TOTAL STROKE(mm)	CYLINDER CAPACITY CLAMP(cm <sup>3</sup> )	CYLINDER CAPACITY UNCLAMP(cm <sup>3</sup> )	EFF.PISTON AREA CLAMP(cm <sup>2</sup> )	EFF.PISTON AREA UNCLAMP(cm <sup>2</sup> )	RANGE OF TEMPERATURE(°C)
CTMA-025	308	17.5	3	20.5	0.5	2.1	1.13	0.35	0~+70°C
CTMA-040	424	20.5	3	23.5	1.0	3.6	1.539	0.409	0~+70°C
CTMA-060	645	23	3	26	2.6	6.6	2.545	1.006	0~+70°C
CTMA-100	1018.5	26.5	3	29.5	3.7	11.2	3.801	1.256	0~+70°C
CTMA-160	1724	32	3	35	8.2	21.6	6.158	2.357	0~+70°C
CTMA-250	2441.7	38	3	41	7.7	33	8.042	1.884	0~+70°C

### 外形尺寸 External Dimensions

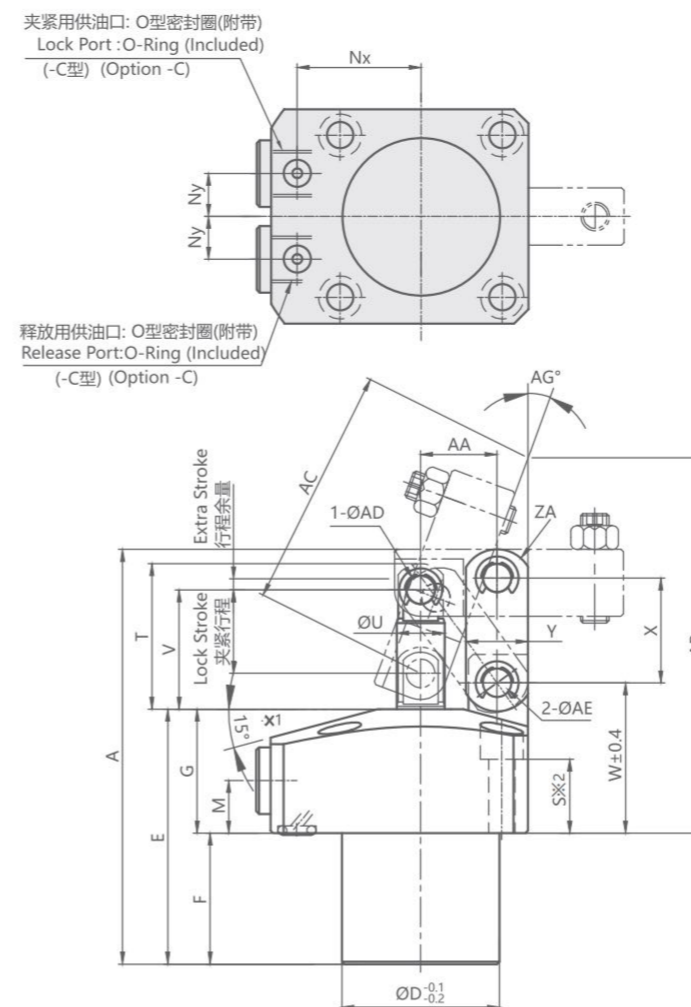

C: 板式连接型(附带G螺纹堵头)  
C: Gasket Option(With G Thread Plug)  
※本图表示CTMA-C型的夹紧状态。  
※The drawing shows the Clamping state of CTMA-C.

### 安装部位加工尺寸 Machining Dimensions of Mounting Area

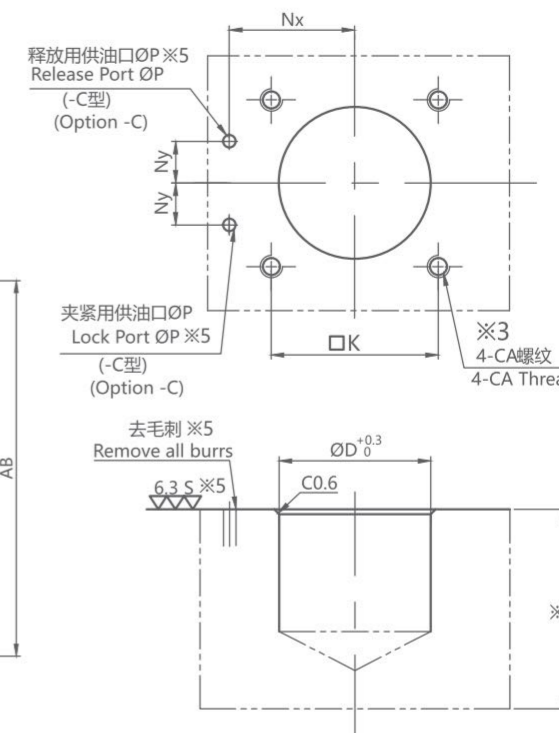

### 配管方式 Piping Method

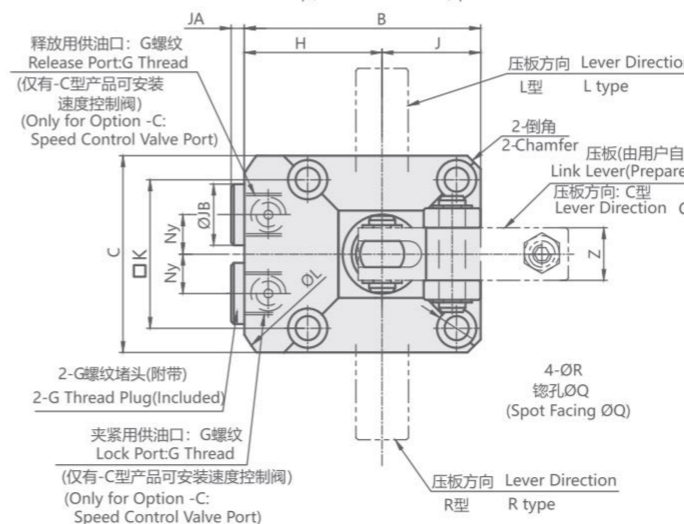

B: 外配管型(G螺纹)  
B: Piping Option(G Thread)  
※本图表示CTMA-BC型的夹紧状态。  
※The drawing shows the clamping state of CTMA-BC.

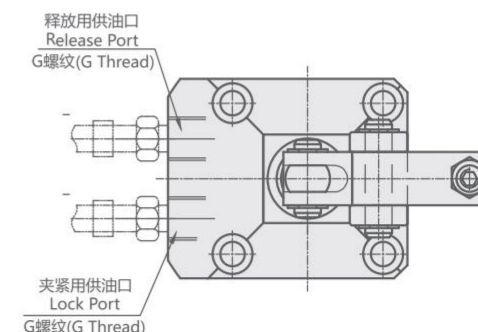

### 注意事项

- ※1.只有CTMA-100法兰的倾斜角度为12°。
- ※2.本产品未附带安装螺栓, 请用户参考S尺寸并根据安装高度自行配备。
- ※3.请参考S尺寸并根据安装高度决定安装螺栓的CA螺纹深度。
- ※4.请参考F尺寸,并根据安装高度决定本体安装孔φD的深度。
- ※5.本加工表示-C: 板式连接型的情况。

### NOTE

- ※1. Flange inclination angle is 12° only for CTMA-100.
- ※2. Mounting bolts are not provided. Please prepare them according to the mounting height referring to dimension "S".
- ※3. CA tapping depth of the mounting bolt should be decided according to the mounting height referring to dimension "S".
- ※4. The depth of the body mounting hole φD should be decided according to the mounting height referring to dimension "F".
- ※5. The machining dimension is for -C: Gasket option.

外形尺寸及安装部位加工尺寸表

External Dimensions and Machining Dimensions for Mounting

Unit:mm

型号 Model item	CTMA-025□□	CTMA-040□□	CTMA-060□□	CTMA-100□□	CTMA-160□□	CTMA-250□□
全行程 Full Stroke	20.5	23.5	26	29.5	35	41
夹紧行程 Lock Stroke	17.5	20.5	23	26.5	32	38
行程余量 Extra Stroke	3	3	3	3	3	3
A	87	97.5	108.5	122.5	151	175.5
B	54	61	69	82.5	94.5	109.5
C	45	51	60	73	85	100
D	33	36	43	48	60	70
E	53.5	58.5	63	68.5	84	96.5
F	27.5	30.5	33	35.5	46	54.5
G	26	28	30	33	38	42
H	31.5	35.5	39	46	52	59.5
J	22.5	25.5	30	36.5	42.5	50
K	34	40	47	57	65	75
L	73	81	88	103	116	136
M	11	12	13	14	16	17
Nx	26	30	33.5	40	45	52.5
Ny	9	10	12	15	16	18.5
P	3	3	3	3	5	5
Q	9	9	11	14	17.5	20
R	5.5	5.5	6.8	9	11	14
S	15.5	16.5	16	17.5	17.5	18
T	30.5	35	37.5	45	55	64.5
U	10	12	14	18	22	28
V	25	29	31.5	37	45	52
W	31.5	34.5	37.5	42	49	54.5
X	22	26	30	35.5	43.5	52.5
Y	13	13	16	19	25	28
Z	21	21	28	37	40	49
ZA	R7.5	R7.5	R10	R12	R15	R16
倒角 Chamfer	3	3	3	4	5	8
AA	16	18.5	21	24.5	30	36
AB	78.7	92.4	103.9	118.4	131.8	148.5
AC	50.2	61.2	71.7	83	90.8	104.6
AD	6	6	6	8	10	12
AE	6	6	8	10	12	15
AG	20.2	18.9	19.9	20.5	21.5	22.4
CA (Nominal X Pitch)	M5 X0.8	M5 X0.8	M6 X1	M8X1.25	M10X1.5	M12X1.75
JA	3	3	3	3	3.5	3.5
JB	14	14	14	14	19	19
G 螺纹 G Thread	G1/8	G1/8	G1/8	G1/8	G1/4	G1/4
O形密封圈(-C型) O-ring (Option-C)	1BP5	1BP5	1BP5	1BP5	1BP7	1BP7

杠杆压板设计尺寸 Link Lever Design Dimension

※供设计制作压板时参考。※Reference for designing link lever.

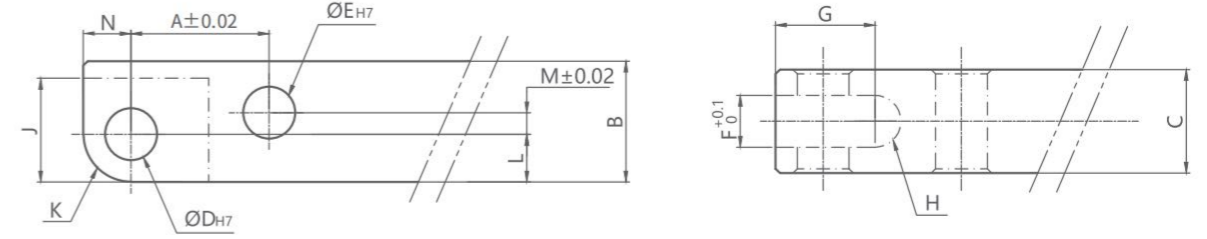

压板尺寸 External Dimensions

Unit:mm

MODEL ITEM	CTMA-025	CTMA-040	CTMA-060	CTMA-100	CTMA-160	CTMA-250
A	16	18.5	21	24.5	30	36
B	14	16	20	25	32	38
C	12 <sup>0</sup> <sub>-0.3</sub>	12 <sup>0</sup> <sub>-0.3</sub>	16 <sup>0</sup> <sub>-0.3</sub>	19 <sup>0</sup> <sub>-0.3</sub>	22 <sup>0</sup> <sub>-0.3</sub>	25 <sup>0</sup> <sub>-0.3</sub>
D	6 <sup>+0.012</sup> <sub>0</sub>	6 <sup>+0.012</sup> <sub>0</sub>	6 <sup>+0.012</sup> <sub>0</sub>	8 <sup>+0.015</sup> <sub>0</sub>	10 <sup>+0.015</sup> <sub>0</sub>	12 <sup>+0.018</sup> <sub>0</sub>
E	6 <sup>+0.012</sup> <sub>0</sub>	6 <sup>+0.012</sup> <sub>0</sub>	8 <sup>+0.015</sup> <sub>0</sub>	10 <sup>+0.015</sup> <sub>0</sub>	12 <sup>+0.018</sup> <sub>0</sub>	15 <sup>+0.018</sup> <sub>0</sub>
F	6	6	8	10	11	13
G	11.5	13	12.5	16	20	24
H	R3	R3	R4	R5	R5.5	R6.5
J	12	13	13	17.5	22	26
K	R5.5	R6	R6	R8	R10	R11
L	5.5	6	6	8	10	11
M	2.5	3.5	6	7.5	9.5	13
N	5.5	6	6	8	10	11

注意事项

- 1.设计加工压板时请勿超出上表中规定的尺寸范围，否则夹紧力将无法达到规格值并可能造成变形，卡滞，动作不正常的故障。
- 2.压板安装用销钉请使用附带的销钉(ØADf6, ØAEf6)。

附件：压板  
Accessories: Link Lever

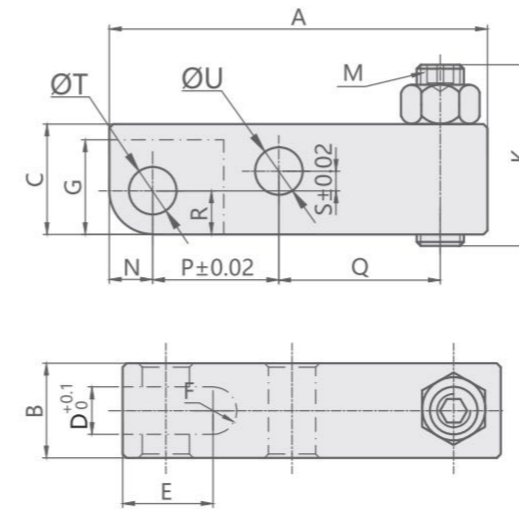

注意事项

- 1.材质：S45C。
- 2.压板安装用销钉请使用附带的销钉(ØADf6, ØAEf6)。

NOTE

- 1.Do not exceed the size range specified in the table above when designing and processing the clamping plate. Otherwise, the clamping force will not meet the specifications and may cause deformation, stuck, and abnormal operation.
- 2.Please use the attached pin(equivalent to ØADf6, ØAEf6) as the mounting pin for lever clamping plate.

Unit:mm

MODEL ITEM	CTMA-025	CTMA-040	CTMA-060	CTMA-100	CTMA-160	CTMA-250
A	48	54	64	74.5	88.5	102.5
B	12 <sup>0</sup> <sub>-0.3</sub>	12 <sup>0</sup> <sub>-0.3</sub>	16 <sup>0</sup> <sub>-0.3</sub>	19 <sup>0</sup> <sub>-0.3</sub>	22 <sup>0</sup> <sub>-0.3</sub>	25 <sup>0</sup> <sub>-0.3</sub>
C	14	16	20	25	32	38
D	6	6	8	10	11	13
E	14.5	16	16.5	21	25.5	30.5
F	R3	R3	R4	R5	R5.5	R6.5
G	12	13	13	17.5	22	26
K	23	26	32	39	47	56
M	M6	M6	M8	M10	M12	M16
N	5.5	6	6	8	10	11
P	16	18.5	21	24.5	30	36
Q	20.5	23.5	29	32	37.5	41.5
R	5.5	6	6	8	10	11
S	2.5	3.5	6	7.5	9.5	13
T	6 <sup>+0.012</sup> <sub>0</sub>	6 <sup>+0.012</sup> <sub>0</sub>	6 <sup>+0.012</sup> <sub>0</sub>	8 <sup>+0.015</sup> <sub>0</sub>	10 <sup>+0.015</sup> <sub>0</sub>	12 <sup>+0.018</sup> <sub>0</sub>
U	6 <sup>+0.012</sup> <sub>0</sub>	6 <sup>+0.012</sup> <sub>0</sub>	8 <sup>+0.015</sup> <sub>0</sub>	10 <sup>+0.015</sup> <sub>0</sub>	12 <sup>+0.015</sup> <sub>0</sub>	15 <sup>+0.018</sup> <sub>0</sub>

NOTE

- 1.Material: S45C.
- 2.Please use the attached pin(equivalent to ØADf6, ØAEf6) as the mounting pin for clamping plate.

# CCLW

## 高压紧凑型杠杆式油压缸

## CCLW HIGH PRESSURE LEVERAGE CLAMP



### 产品特性

此系列产品配件采用优化设计,与传统产品比较夹紧能力提高了。产品支撑点部位与缸体采用一体化结构,使体积更加扎实,提高了产品强度。产品采用了专用防尘设计,提高了防尘和密封性,实现了高密封性。产品法兰下部采用缩小设计,适合夹具要求的紧凑化和轻量化。

最大操作压力: 350kgf/cm<sup>2</sup>  
 最小操作压力: 10kgf/cm<sup>2</sup>  
 CCLW-04除外, 最小操作压力30 kgf/cm<sup>2</sup>  
 作动方式: 复动式

### 注意事项

夹紧及放松作动速度需适当放缓。  
 可接受订制, 欢迎与本公司洽询。

### FEATURES

The accessories of the CCLW series are optimally designed and the clamping capacity has increased immensely compared to the traditional products. The cylinder and its supporting point use an integrated structure to create a more compact-sized product with enhanced strength. With its special dust-proof design, this product has improved its sealing performance and protects against any particles or debris while in use. The lower flange adopts a volume-compressed design, specifically to operate efficiently under the fixture's lightweight requirements.

Max. operating pressure: 350 kgf/cm<sup>2</sup>  
 Min. operating pressure: 10 kgf/cm<sup>2</sup>  
 Except CCLW-04, Min. operating pressure: 30kgf/cm<sup>2</sup>  
 Double acting

### NOTE

The action and the speed of clamping / undamping needs to be slowed down appropriately.  
 Customization is available upon request, please contact us for more info.

### 剖面图 Sectional view

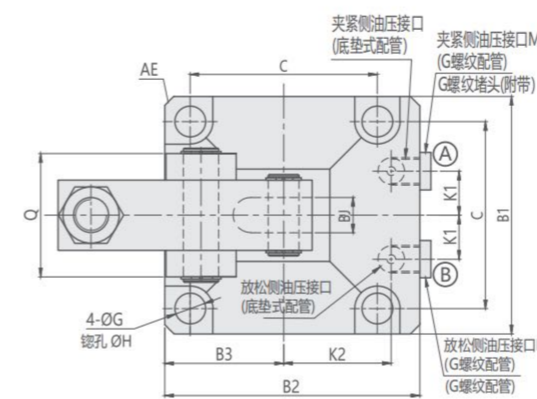
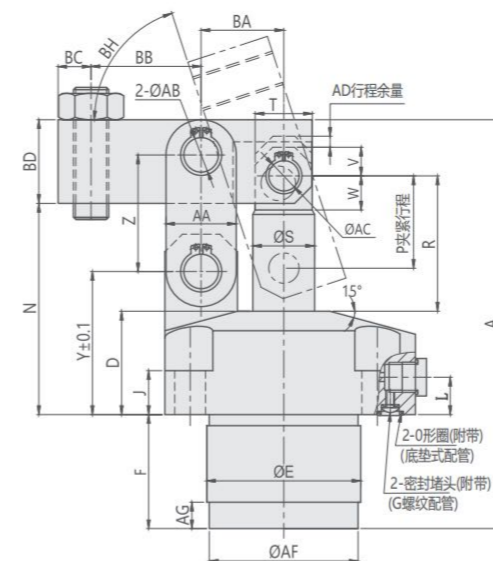
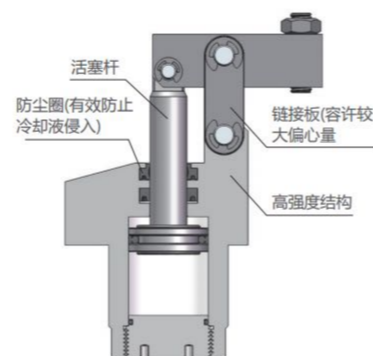

### 压臂安装方向 Lever Direction

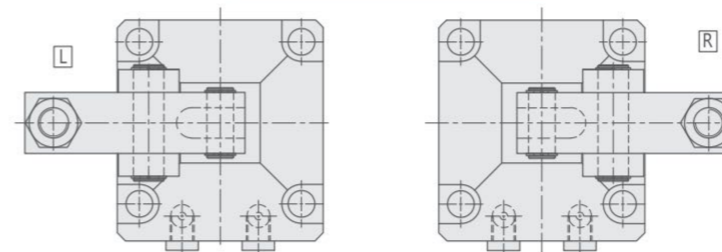

① 夹持油孔 Clamping port

② 放松油孔 Unclamping port

### 订购标示法 ORDERING INDICATION

示例: CCLW-04L

CCLW	系列 Series	CCLW
04	04/06/10/16/25	
L	压臂安装方向 Lever direction	空白:标准 R: 右 L: 左
		Blank: Standard R: Right L: Left

Unit:mm

MODEL ITEM	CCLW -04	CCLW -06	CCLW -10	CCLW -16	CCLW -25
A	100	122	132.5	162	197
B1	50	60	70	86	108
B2	60	69	77	96	110
B3	25	30	35	43	54
C	40	47	54	65	85
D	26.5	31	32.5	40	47
E	35 <sup>0</sup> <sub>-0.2</sub>	45 <sup>0</sup> <sub>-0.2</sub>	50 <sup>0</sup> <sub>-0.2</sub>	60 <sup>0</sup> <sub>-0.2</sub>	70 <sup>0</sup> <sub>-0.2</sub>
F	31.5	42.5	42.5	51	63
G	5.5	6.8	9	11	14
H	10	12	15	18.5	20.5
J	17	17	17	20	21
K1	11	11.5	13	15	20
K2	27.5	30	33	40	43
L	12.5	15	15	17	17
M	G 1/8	G 1/8	G 1/8	G 1/4	G 1/4
N	52.5	59.5	65	80	96
P	20.5	23	26.5	33	42
Q	21	28	37	46	56
R	32	34.5	40.5	49	61.5
S	12	14	18	22.4	28
T	10	12	15	20	26
V	6	6	8	11	13
W	7	7	9	10.8	14.5
Y	36	41.5	45	54.5	65
Z	26	30	35.5	44	53
0型圈O-Ring	P9	P9	P9	P9	P9
AA	13	15	19	25	32
AB	6 <sup>+0.012</sup> <sub>0</sub>	8 <sup>+0.012</sup> <sub>0</sub>	10 <sup>+0.015</sup> <sub>0</sub>	14 <sup>+0.015</sup> <sub>0</sub>	16 <sup>+0.018</sup> <sub>0</sub>
AC	6 <sup>+0.012</sup> <sub>0</sub>	6 <sup>+0.012</sup> <sub>0</sub>	8 <sup>+0.015</sup> <sub>0</sub>	12 <sup>+0.015</sup> <sub>0</sub>	14 <sup>+0.018</sup> <sub>0</sub>
AD	3	3	3	3	3
AE	C2.5	C2.5	C3	C3.5	C5.5
AF	-	43	48	57.5	67.5
AG	-	10	10	12	12
BA	18.5	21	24.5	30.5	37.5
BB	23.5	29	32	39	50
BC	6	8	10	11	15
BD	16	20	25	31	38
BG	92.5	107.9	117.4	144.7	189.2
BH	约71°	约70°	约70°	约69°	约72°
BJ	6 <sup>0.1</sup> <sub>0.02</sub>	8 <sup>0.1</sup> <sub>0.02</sub>	10 <sup>0.1</sup> <sub>0.02</sub>	11 <sup>0.1</sup> <sub>0.02</sub>	16 <sup>0.1</sup> <sub>0.02</sub>

### 规格参数表 SPECIFICATIONS

型号	理论夹持力 (150 kgf/cm <sup>2</sup> )	夹紧行程	总行程	推出容积	拉入容积	推出受压面积	拉入受压面积	使用温度范围	使用流体
MODEL	CLAMPING FORCE AT 150 kgf/cm <sup>2</sup> (kgf)	CLAMPING STROKE (mm)	TOTAL STROKE (mm)	CYLINDER CAPACITY CLAMP (cm <sup>3</sup> )	CYLINDER CAPACITY UNCLAMP (cm <sup>3</sup> )	EFF.PISTON AREA CLAMP (cm <sup>2</sup> )	EFF.PISTON AREA UNCLAMP (cm <sup>2</sup> )	RANGE OF TEMPERATURE (°C)	USABLE FLUID
CCLW-04	181	20.50	23.50	3.60	1.00	1.54	0.41	-10~+70°C	相当于ISO黏度等级的ISO-VG-32一般液压油 Recommended: ISO-VG-32 hydraulic oil equivalent to ISO viscosity grade
CCLW-06	275	23.00	26.00	6.60	2.60	2.54	1.00	-10~+70°C	
CCLW-10	436	26.50	29.50	11.20	3.70	3.80	1.26	-10~+70°C	
CCLW-16	722	33.00	36.00	22.20	8.00	6.16	2.22	-10~+70°C	
CCLW-25	1145	42.00	45.00	45.80	18.10	10.18	4.03	-10~+70°C	

# CYS

## 摇臂式油压杠杆缸

## CYS ROCKER HYDRAULIC LEVERAGE CLAMP



CYS-3005

CYS-3006

### 产品特性

摇臂式夹器适用于快速换模用(Quick Die change)工位。夹臂(rocker clamp arm)的运作行程短,便于安装无干扰,特别适合狭小的安装控制项。可以用手将夹臂朝自己所希望的方向旋转,模具的组装脱落容易。产品因用枢销连接构成可以坚固,安全地使用。

### FEATURES

This product is suitable for Quick Die Change clamps, and it is made for convenient press die replacement. The clamp lever can be rotated to the desired direction, making it easy to fall off the mold. The short operating stroke of the rocker lever is suitable for a constrained space between the base plates of die. It is connected to the pivot pin and can be used firmly and safely.

使用油压范围: 15~250kgf/cm<sup>2</sup>  
使用环境温度: 0~60°C  
作动方式: 单动式

Operating Pressure: 15~250kgf/cm<sup>2</sup>  
Operating Temperature: 0~60°C  
Single acting

### 注意事项

利用下面的螺母和标准T-槽形螺母等进行安装,依据托架孔高度的面,可以以多种方法调整夹紧高度。

### NOTE

It can be installed using a female thread on the bottom and a standard T-slot nut, and the clamping height can be adjusted by the space according to the mounting hole height.

### 订购标示法 ORDERING INDICATION

示例: CYS-3005

CYS	系列 Series	CYS	
30	油缸内径 Hydraulic cylinder inside diameter	30	
05	行程 Stroke	05= 5mm	06= 6mm

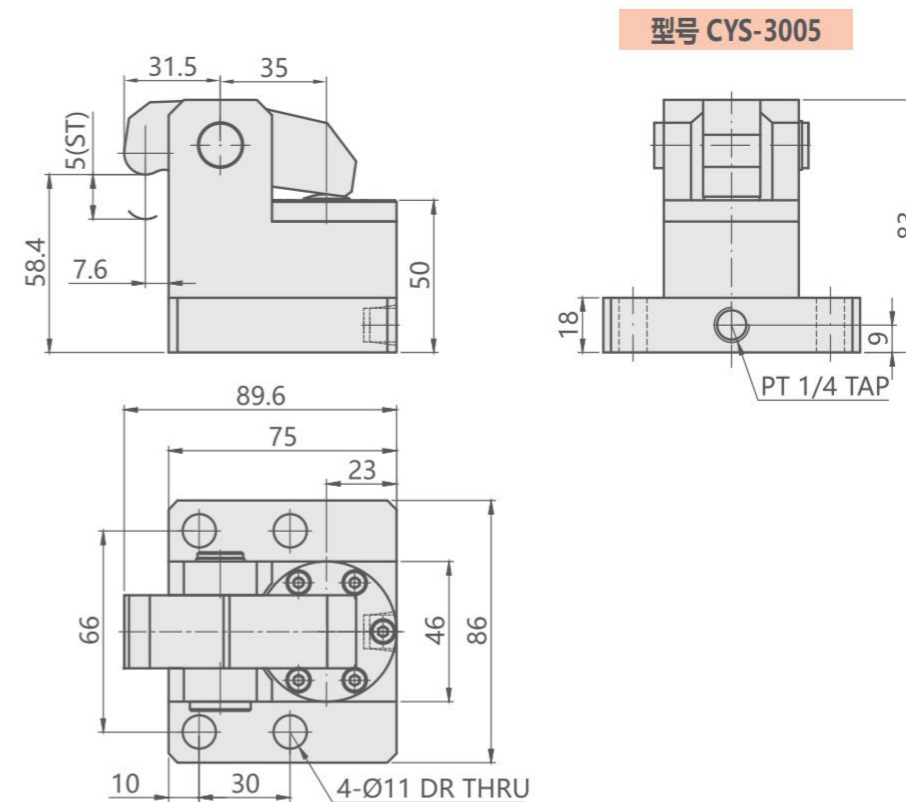

型号 CYS-3006

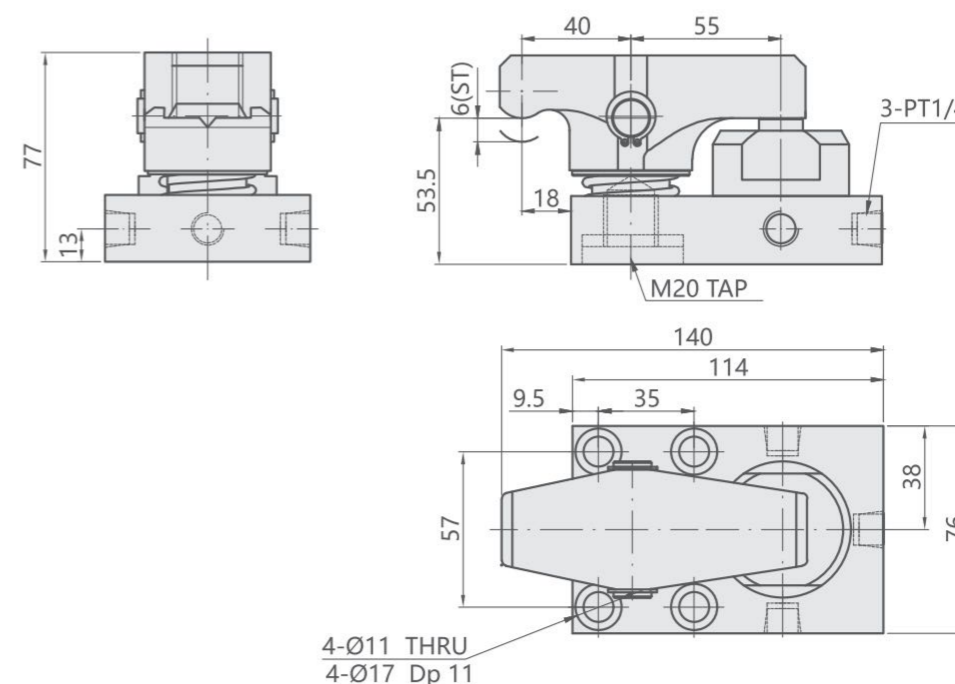

### 规格参数表 SPECIFICATIONS

型号 MODEL	行程 STROKE (mm)	油缸容量 CYLINDER CAPACITY(cm <sup>3</sup> )	油缸面积 CYLINDER AREA(cm <sup>2</sup> )	最大夹紧力 MAXIMUM CLAMPING FORCE(kgf)	重量 WEIGHT(kg)
CYS-3005	5.0	3.5	7.0	1900	2.2
CYS-3006	6.0	4.2	7.0	2400	2.6

# CLP

## 空心式夹紧器

## CLP HOLLOW CLAMP

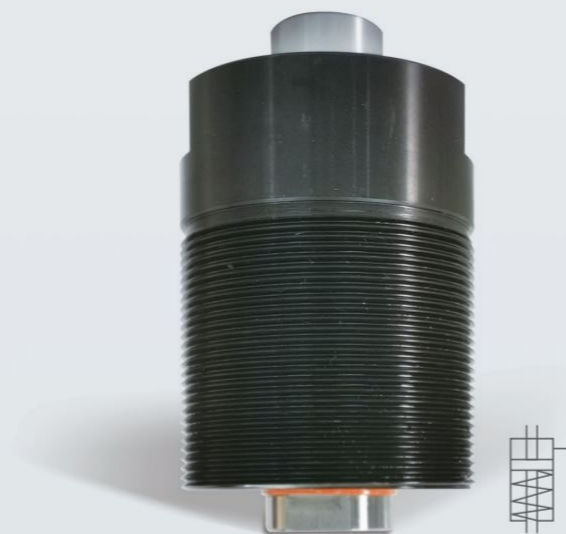

### 产品特性

主杆孔贯通,端部有内螺纹,根据安装工位,可以用于拉开或推开的功能。

使用油压范围:15-250kgf/cm<sup>2</sup>  
 活塞速度:8~100mm/s  
 使用环境温度:0~60°C  
 油路尽量要大  
 作动方式:单动式

### FEATURES

There is a hole through the rod so bolts can be used,as there is a female screw at the end.Depending on the mounting position it can be used for pushing or pulling.

Operating Pressure:15-250kgf/cm<sup>2</sup>  
 Piston Speed:8~100mm/s  
 Operating Temperature:0~60°C  
 Make piping size as big as possible.  
 Single acting.

### 订购标示法 ORDERING INDICATION

#### 示例: CLP-2808

CLP	系列 Series	CLP
28	油缸内径 Hydraulic cylinder inside diameter	28/40/63
08	行程 Stroke	08=8mm 12=12mm 20=20mm

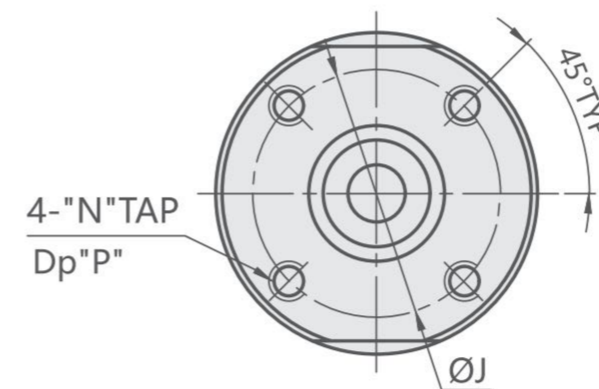
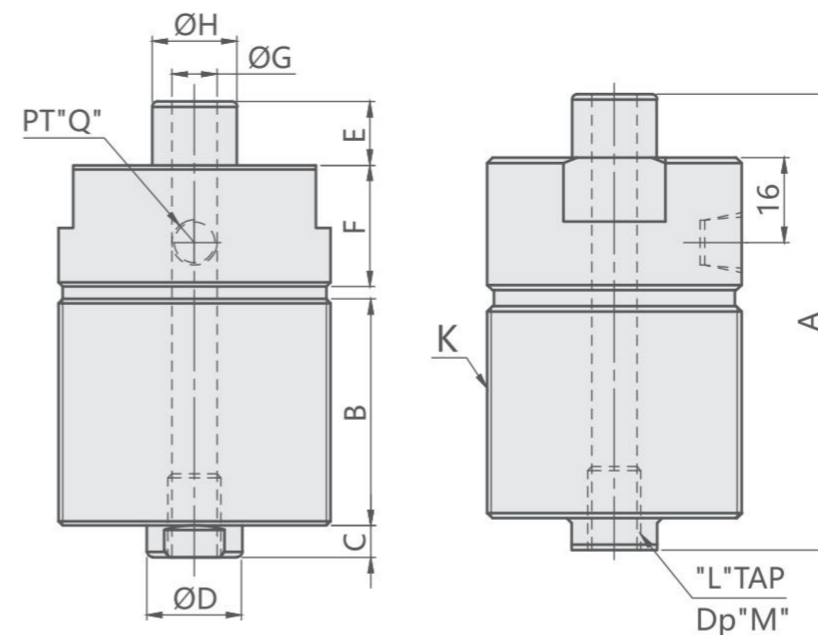

### 尺寸 Dimensions Unit:mm

MODEL NO.	CLP-2808	CLP-4012	CLP-6320
A	86	109	140
B	40	53	70
C	6	9	10
ØD	18	28	40
E	12	15	23
F	25	29	34
ØG	11	17	21
ØH	16	25	35
ØJ	37	50	70
K	M48x1.5P	M65x2.0P	M90x2.0P
L	M10x1.5P	M12x1.75P	M24x3.0P
M	15	20	32
N	M6x1.0P	M8x1.25P	M12x1.75P
P	10	16	18
Q	1/8	1/4	3/8

### 规格参数表 SPECIFICATIONS

型号	行程	油缸容量	油缸面积	最大夹紧力	内径	重量
MODEL	STROKE (mm)	CYLINDER CAPACITY(cm <sup>3</sup> )	CYLINDER AREA(cm <sup>2</sup> )	MAXIMUM CLAMPING FORCE(kgf)	INSIDE DIAMETER(mm)	WEIGHT(kg)
CLP-2808	8	3.31	4.14	1000	Ø28	0.85
CLP-4012	12	9.18	7.65	1900	Ø40	1.91
CLP-6320	20	43.08	21.54	5300	Ø63	4.28

# CHA

## 油压转角缸

### CHA HYDRAULIC SWING CLAMP



#### 产品特性

此系列产品配件采用优化设计,使体积更加紧凑,提高了产品强度。产品采用了专用防尘设计,提高了防尘和密封性实现了高密封性。产品结构具有高抗扭矩性,实现了高耐久性。

最大操作压力: 70kgf/cm<sup>2</sup>  
 最小操作压力: 15kgf/cm<sup>2</sup>  
 作动方式: 复动式

#### FEATURES

The accessories of the CHA series are optimally designed to create a more compact-sized product with enhanced strength. With its special dust-proof design, this product has improved its sealing performance and protects against any particles or debris while in use. The product's structure design has a high torsion resistance that achieves maximum durability.

Max. operating pressure: 70kgf/cm<sup>2</sup>  
 Min. operation pressure: 15kgf/cm<sup>2</sup>  
 Double acting

#### 剖面图 Sectional view

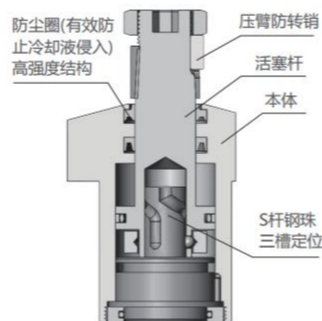

#### 注意事项

夹紧及放松作动速度需适当放缓。压臂安装拆卸方式,请参见第4页。可接受订制,欢迎与本公司洽询。

#### NOTE

The action and the speed of clamping / unclamping needs to be slowed down appropriately. Please refer to Page 4 for installation instructions or removal methods of the clamping arm. Customization is available upon request, please contact us for more info.

#### 订购标示法 ORDERING INDICATION

示例: CHA-040SL-90GQM

CHA	系列 Series	CHA
040	主体尺寸 Body size	036: Φ1=36 040: Φ1=40 048: Φ1=48 055: Φ1=55 065: Φ1=65 075: Φ1=75 090: Φ1=90 105: Φ1=105
S	压臂型式 Clamping arm type	S: 单边压臂 D: 双边压臂 S: Single side arm D: Double side arm (注:双压臂的无双出杆型)
L	转角方向 Swing direction	L: 左 R: 右 L: Left R: Right
90	转角角度 Swing angle	标准角度 可订做角度 Standard angle 90°(±2°) Order angle 30°(±2°), 45°(±2°), 60°(±2°)
G	型式 Type	空白: 配管式 G: 油路板式 C: 油路板式附调速 Blank: Line type G: Manifold type C: Manifold with flow control
Q	加长行程 Extended stroke	具体规格请参见尺寸数据表。Please refer the spec in the dimension table. 注: 加长行程无气检型 Note: extended stroke no air sensor option
M	无符号: 空白(标准) M: 空气感测器板式连接型 N: 空气感测器管式连接型 ※D: 双出杆型	Blank: Standard M: Air sensor manifold option N: Air sensor piping option ※D: Double end rod option

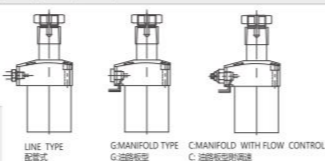

#### SINGLE SIDE SWING CLAMP

#### DOUBLE SIDE SWING CLAMP

注: 下图为转角90°松开状态

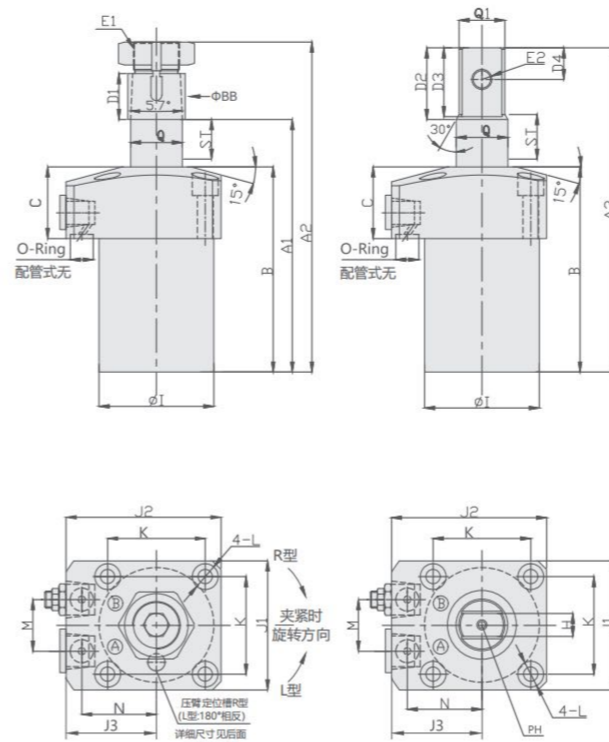

- Ⓐ 夹持油孔 Clamping port
- Ⓑ 放松油孔 Unclamping port

MODEL ITEM	CHA-036	CHA-040	CHA-048	CHA-055	CHA-065	CHA-075	CHA-090	CHA-105
ST: Swing / Clamp	13.5:5.5/8	14.5:6.5/8	15.5:7.5/8	18.5:8.5/10	20:10/10	24:12/12	26:14/12	32:16/16
A1松开状态 Unclamping	80	88	96.5	109.5	116	135	148	178
A2松开状态 Unclamping	104	115	128.5	145.5	156	181	203	240
A3松开状态 Unclamping	102	113	126.5	143.5	156	181	203	238
B	64.5	71.5	79	89	94	109	120	144
C	25	25	28	30	31	38	46	56
D1	14	16	19	22	25	31	38	44
D2	22	25	29	33	40	45	54	60
D3	21	24	27.5	31.5	38.5	43.5	52.5	58.5
D4	9	11	12	12.5	16.5	19	23.5	25.5
E1	M14X1.5	M16X1.5	M20X1.5	M22X1.5	M27X1.5	M30X1.5	M39X1.5	M48X1.5
E2	Φ6	Φ6	Φ8	Φ10	Φ13	Φ13	Φ16	Φ20
H	7	8	10	12	14	16	22	26
ΦI	Φ36	Φ40	Φ48	Φ55	Φ65	Φ75	Φ90	Φ105
J1	40	45	51	60	70	80	95	110
J2	49	54	61	69	81	92	107	122
J3	29	31.5	35.5	39	46	52	59.5	67
K	□31.4	□34	□40	□47	□55	□63	□75	□88
L	Φ4.5-Φ7.5 X5D	Φ5.5-Φ9 X6D	Φ5.5-Φ9 X6D	Φ6.8-Φ11 X7D	Φ6.8-Φ11 X7D	Φ9-Φ14 X9D	Φ11-Φ17.5 X11D	Φ14-Φ20 X14D
M	16	18	22	24	30	32	37	45
N	23.5	26	30	33.5	39.5	45	52.5	60
Q	Φ15	Φ18	Φ22	Φ25	Φ30	Φ35.5	Φ45	Φ55
Q1	Φ13.5	Φ16	Φ20	Φ23	Φ28	Φ33.5	Φ43	Φ53
ΦBB	Φ17	Φ20	Φ25	Φ28	Φ34	Φ40	Φ49	Φ60
PH	M3	M3	M4	M5	M6	M6	M8	M8
配管式油口 Port with Line type	2-PT1/8	2-PT1/8	2-PT1/8	2-PT1/8	2-PT1/4	2-PT1/4	2-PT3/8	2-PT3/8
O型圈(仅G/C型) O-Ring(G/C type)	P5	P5	P5	P5	P7	P7	P7	P7

#### 规格参数表 SPECIFICATIONS

型号	理论夹持力 (70 kgf/cm <sup>2</sup> )	转角行程	夹紧行程	总行程	推出容积	拉入容积	推出受压面积	拉入受压面积	使用温度范围	使用流体
MODEL	CLAMPING FORCE AT 70 kgf/cm <sup>2</sup> (kgf)	SWING STROKE (mm)	CLAMPING STROKE (mm)	TOTAL STROKE (mm)	CYLINDER CAPACITY UNCLAMP (cm <sup>3</sup> )	CYLINDER CAPACITY CLAMP (cm <sup>3</sup> )	EFF.PISTON AREA UNCLAMP (cm <sup>2</sup> )	EFF.PISTON AREA CLAMP (cm <sup>2</sup> )	RANGE OF TEMPERATURE (°C)	USABLE FLUID
CHA-036	220	5.5	8	13.5	6.63	4.24	4.91	3.14	-10~+70°C	相当于ISO黏度等级的ISO-VG-32一般液压油 Recommended: ISO-VG-32 hydraulic oil equivalent to ISO viscosity grade
CHA-040	284.2	6.5	8	14.5	9.57	5.89	6.6	4.06	-10~+70°C	
CHA-048	445.9	7.5	8	15.5	15.76	9.87	10.17	6.37	-10~+70°C	
CHA-055	721	8.5	10	18.5	28.12	19.06	15.2	10.3	-10~+70°C	
CHA-065	880	10	10	20	38.60	25.14	19.63	12.57	-10~+70°C	
CHA-075	1421	12	12	24	72.46	48.7	30.19	20.3	-10~+70°C	
CHA-090	1978	14	12	26	114.82	73.48	44.16	28.26	-10~+70°C	
CHA-105	2789	16	16	32	203.50	127.5	63.59	39.84	-10~+70°C	

注: 下图以CHA-M型松开状态

Unit:mm

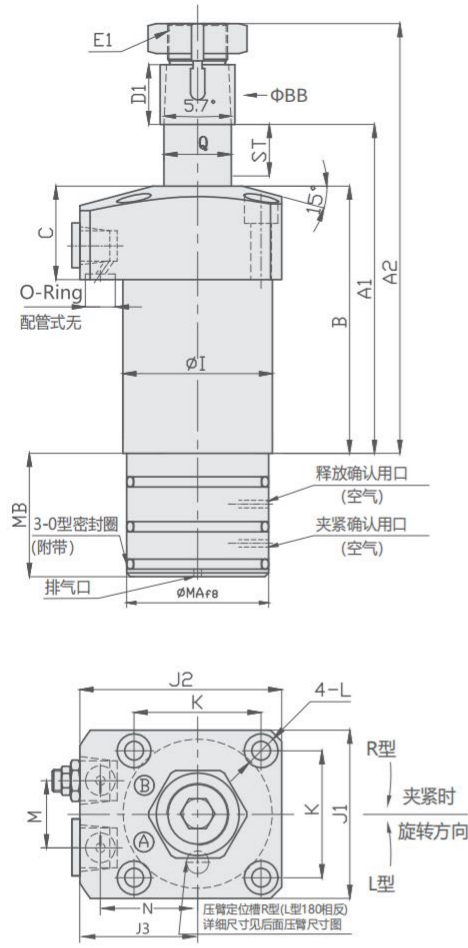

注: 安装部位加工尺寸

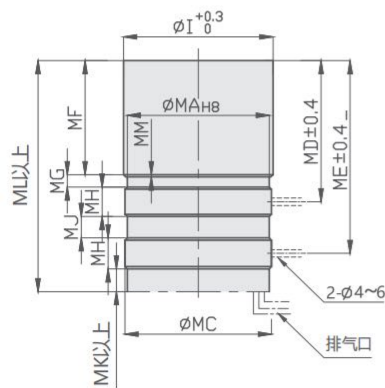

Ⓐ 夹持油孔 Clamping port  
Ⓑ 放松油孔 Unclamping port

MODEL ITEM	CHA-036M	CHA-040M	CHA-048M	CHA-055M	CHA-065M	CHA-075M	CHA-090M	CHA-105M
ST:Swing /Clamp	13.5:5.5/8	14.5:6.5/8	15.5:7.5/8	18.5:8.5/10	20:10/10	24:12/12	26:14/12	32:16/16
A1松开状态 Unclamping	80	88	96.5	109.5	116	135	148	178
A2松开状态 Unclamping	104	115	128.5	145.5	156	181	203	240
B	64.5	71.5	79	89	94	109	120	144
C	25	25	28	30	31	38	46	56
D1	14	16	19	22	25	31	38	44
E1	M14X1.5	M16X1.5	M20X1.5	M22X1.5	M27X1.5	M30X1.5	M39X1.5	M48X1.5
ΦI	Φ36	Φ40	Φ48	Φ55	Φ65	Φ75	Φ90	Φ105
J1	40	45	51	60	70	80	95	110
J2	49	54	61	69	81	92	107	122
J3	29	31.5	35.5	39	46	52	59.5	67
K	□31.4	□34	□40	□47	□55	□63	□75	□88
L	Φ4.5-Φ7.5 X5D	Φ5.5-Φ9 X6D	Φ5.5-Φ9 X6D	Φ6.8-Φ11 X7D	Φ6.8-Φ11 X7D	Φ9-Φ14 X9D	Φ11-Φ17.5 X11D	Φ14-Φ20 X14D
M	16	18	22	24	30	32	37	45
N	23.5	26	30	33.5	39.5	45	52.5	60
Q	Φ15	Φ18	Φ22	Φ25	Φ30	Φ35.5	Φ45	Φ55
ΦBB	Φ17	Φ20	Φ25	Φ28	Φ34	Φ40	Φ49	Φ60
配管式油口 Port with Line type	2-PT1/8	2-PT1/8	2-PT1/8	2-PT1/8	2-PT1/4	2-PT1/4	2-PT3/8	2-PT3/8
O型圈(仅G/C型) O-Ring(G/Ctype)	P5	P5	P5	P5	P7	P7	P7	P7
MAf8	34.5 <sup>-0.03/-0.06</sup>	38 <sup>-0.03/-0.06</sup>	45 <sup>-0.03/-0.06</sup>	45 <sup>-0.03/-0.06</sup>	45 <sup>-0.03/-0.06</sup>	53 <sup>-0.03/-0.07</sup>	53 <sup>-0.03/-0.07</sup>	53 <sup>-0.03/-0.07</sup>
MAH8	34.5 <sup>-0.04/0</sup>	38 <sup>-0.04/0</sup>	45 <sup>-0.04/0</sup>	45 <sup>-0.04/0</sup>	45 <sup>-0.04/0</sup>	53 <sup>-0.04/0</sup>	53 <sup>-0.04/0</sup>	53 <sup>-0.04/0</sup>
MB	32	33	38.5	38.5	40.5	49	49	57.5
MC	35.7	39.2	46.2	46.2	46.2	54.2	54.2	54.2
MD	49.4	57.5	65.4	73.4	79.4	86.5	89.5	106.5
ME	62.4	70.5	78.9	86.9	92.9	106	109	126
MF	40	47	53	61	65	74	77	94
MG	4.9	6	7.9	7.9	9.9	7.5	7.5	7.5
MH	9	9	9	9	9	10	10	10
MJ	4	4	4.5	4.5	4.5	9.5	9.5	9.5
MK	6.5	6.5	8	8	8	11	11	16.5
ML	73.4	81.5	91.4	99.4	105.4	122	125	147.5
MM	1.1	1.5	1.5	1.5	1.5	1.5	1.5	1.5

注: 下图以CHA-N型松开状态

Unit:mm

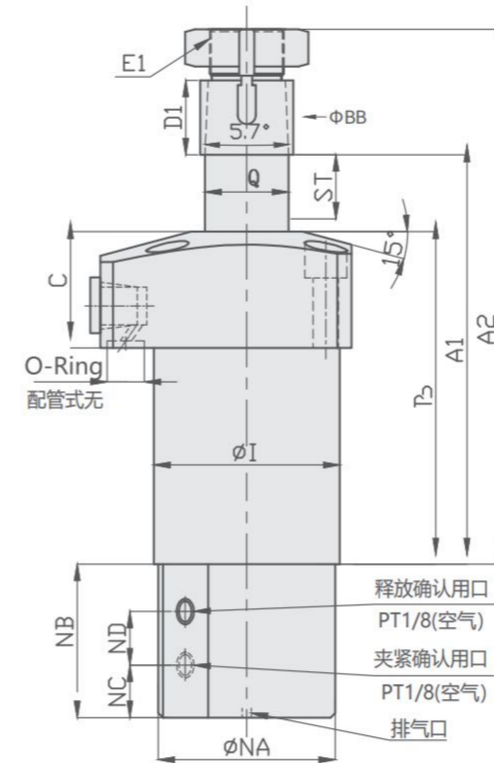
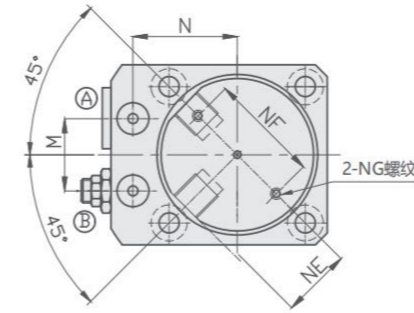

Ⓑ 放松油孔 Unclamping port  
Ⓐ 夹持油孔 Clamping port

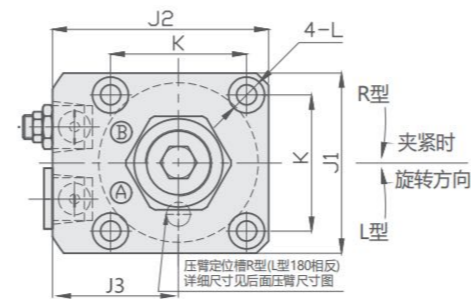

MODEL ITEM	CHA-036N	CHA-040N	CHA-048N	CHA-055N	CHA-065N	CHA-075N	CHA-090N	CHA-105N
ST:Swing /Clamp	13.5:5.5/8	14.5:6.5/8	15.5:7.5/8	18.5:8.5/10	20:10/10	24:12/12	26:14/12	32:16/16
A1松开状态 Unclamping	80	88	96.5	109.5	116	135	148	178
A2松开状态 Unclamping	104	115	128.5	145.5	156	181	203	240
B	64.5	71.5	79	89	94	109	120	144
C	25	25	28	30	31	38	46	56
D1	14	16	19	22	25	31	38	44
E1	M14X1.5	M16X1.5	M20X1.5	M22X1.5	M27X1.5	M30X1.5	M39X1.5	M48X1.5
ΦI	Φ36	Φ40	Φ48	Φ55	Φ65	Φ75	Φ90	Φ105
J1	40	45	51	60	70	80	95	110
J2	49	54	61	69	81	92	107	122
J3	29	31.5	35.5	39	46	52	59.5	67
K	□31.4	□34	□40	□47	□55	□63	□75	□88
L	Φ4.5-Φ7.5 X5D	Φ5.5-Φ9 X6D	Φ5.5-Φ9 X6D	Φ6.8-Φ11 X7D	Φ6.8-Φ11 X7D	Φ9-Φ14 X9D	Φ11-Φ17.5 X11D	Φ14-Φ20 X14D
M	16	18	22	24	30	32	37	45
N	23.5	26	30	33.5	39.5	45	52.5	60
Q	Φ15	Φ18	Φ22	Φ25	Φ30	Φ35.5	Φ45	Φ55
ΦBB	Φ17	Φ20	Φ25	Φ28	Φ34	Φ40	Φ49	Φ60
配管式油口 Port with Line type	2-PT1/8	2-PT1/8	2-PT1/8	2-PT1/8	2-PT1/4	2-PT1/4	2-PT3/8	2-PT3/8
O型圈(仅G/C型) O-Ring(G/Ctype)	P5	P5	P5	P5	P7	P7	P7	P7
ΦNA	35.5	39.5	45	45	45	53	53	53
NB	32	33	38.5	38.5	40.5	49	49	57.5
NC	9.8	9	11	11	11	13	13	17
ND	11.7	13	14.5	14.5	14.5	20.5	20.5	24
NE	17	19	21	21	21	24.5	24.5	24.5
NF	25	29	29	29	29	38	38	38
NG (公称×深度) (Nominal ×Depth)	M3×0.5 ×5	M3×0.5 ×5	M3×0.5 ×5	M3×0.5 ×5	M3×0.5 ×5	M4×0.7 ×6	M4×0.7 ×6	M4×0.7 ×6

注: 本图为CHA-G\*D型松开状态

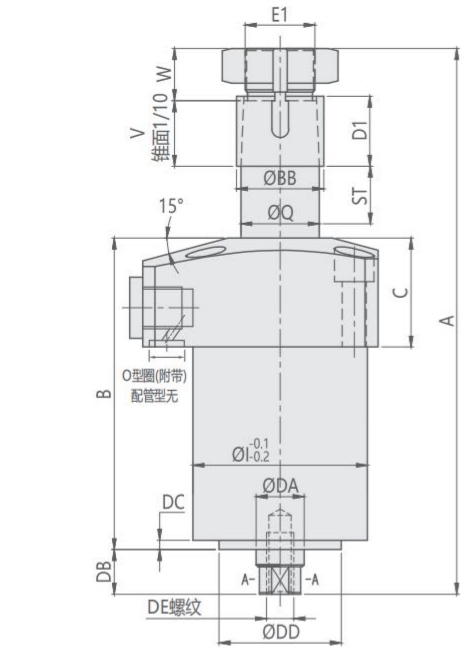

Ⓐ 夹持油孔 Clamping port  
Ⓑ 放松油孔 Unclamping port

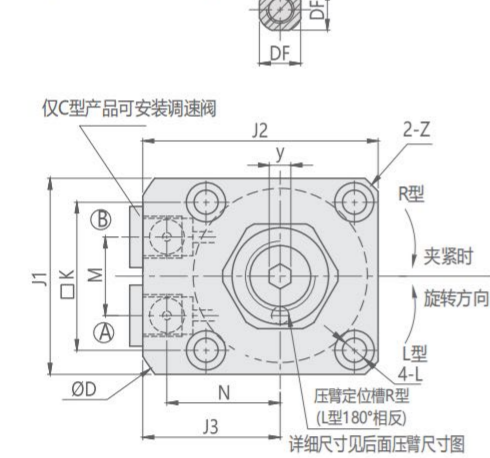

Unit:mm

MODEL ITEM	CHA-036※D	CHA-040※D	CHA-048※D	CHA-055※D	CHA-065※D	CHA-075※D	CHA-090※D	CHA-105※D
ST:Swing /Clamp	13.5:5.5/8	14.5:6.5/8	15.5:7.5/8	18.5:8.5/10	20:10/10	24:12/12	26:14/12	32:16/16
A1松开状态 Unclamping	114.5	128	141.5	158.5	169	194	216	253
B	67	74.5	82	92	97	112	123	147
C	25	25	28	30	31	38	46	56
D1	14	16	19	22	25	31	38	44
W	11	12	14	15	16	16	18	19
V	13	15	18	21	24	30	37	43
ΦBB	Φ17	Φ20	Φ25	Φ28	Φ34	Φ40	Φ49	Φ60
ΦD	Φ66	Φ73	Φ83	Φ88	Φ106	Φ116	Φ136	Φ152
ΦDA	Φ8	Φ12	Φ14	Φ14	Φ14	Φ18	Φ18	Φ18
DB	8	10	10	10	10	10	10	10
DE	M4X10	M6X15	M8X18	M8X18	M8X18	M10X21	M10X21	M10X21
DF	6	10	12	12	12	16	16	16
E1	M14X1.5	M16X1.5	M20X1.5	M22X1.5	M27X1.5	M30X1.5	M39X1.5	M48X1.5
DC	2.5	3	3	3	3	3	3	3
ΦDD	Φ25	Φ29	Φ36	Φ36	Φ43	Φ50	Φ65	Φ80
ΦI	Φ36	Φ40	Φ48	Φ55	Φ65	Φ75	Φ90	Φ105
J1	40	45	51	60	70	80	95	110
J2	49	54	61	69	81	92	107	122
J3	29	31.5	35.5	39	46	52	59.5	67
K	□31.4	□34	□40	□47	□55	□63	□75	□88
L	Φ4.5-Φ7.5 X5D	Φ5.5-Φ9 X6D	Φ5.5-Φ9 X6D	Φ6.8-Φ11 X7D	Φ6.8-Φ11 X7D	Φ9-Φ14 X9D	Φ11-Φ17.5 X11D	Φ14-Φ20 X14D
M	16	18	22	24	30	32	37	45
N	23.5	26	30	33.5	39.5	45	52.5	60
Q	Φ15	Φ18	Φ22	Φ25	Φ30	Φ35.5	Φ45	Φ55
Y	5	6	8	8	10	10	14	14
配管式油口 Port with Line type	2-PT1/8	2-PT1/8	2-PT1/8	2-PT1/8	2-PT1/4	2-PT1/4	2-PT3/8	2-PT3/8
O型圈(仅G/C型) O-Ring(G/C type)	P5	P5	P5	P5	P7	P7	P7	P7
Z(倒角)	C2	C3	C3	C3	C4	C5	C6	C6

下图表示CHA-\*R-90\*-Q松开状态

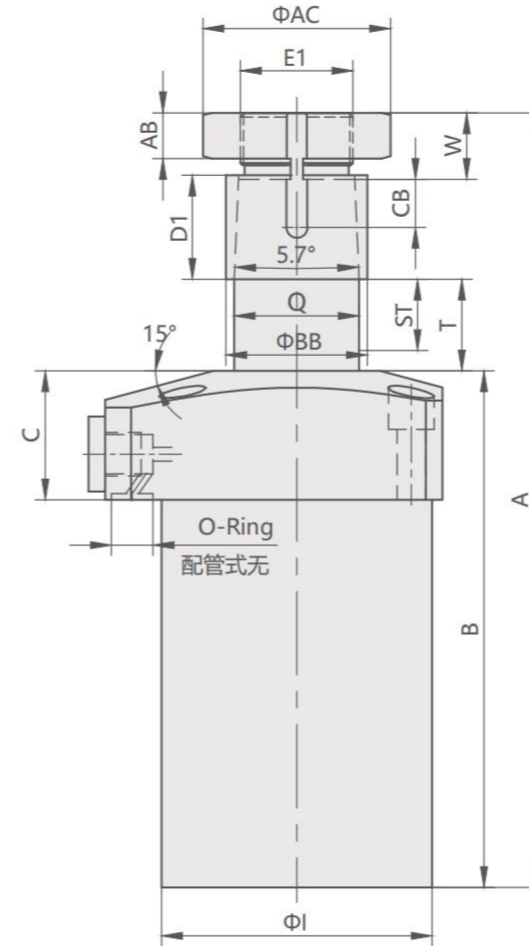

Unit:mm

MODEL ITEM	CHA-036□□-Q□	CHA-040□□-Q□	CHA-048□□-Q□
选型	Q15 Q20 Q25 Q30	Q15 Q20 Q25	Q15 Q20 Q25
ST全行程	20.5 25.5 33 38	21.5 26.5 34.5	22.5 27.5 36
转角行程	5.5 5.5 8 8	6.5 6.5 9.5	7.5 7.5 11
直线行程	15 20 25 30	15 20 25	15 20 25
A松开状态	125 140 162.5 177.5	136 151 175	149.5 164.5 190
B	78.5 88.5 103.5 113.5	85.5 95.5 111.5	93 103 120
C	25 25 25 25	25 25 25	28 28 28
D1	14 14 14 14	16 16 16	19 19 19
E1	M14×1.5	M16×1.5	M20×1.5
ΦI	Φ36 Φ36 Φ36 Φ36	Φ40 Φ40 Φ40	Φ48 Φ48 Φ48
J1	40 40 40 40	45 45 45	51 51 51
J2	49 49 49 49	54 54 54	61 61 61
J3	29 29 29 29	31.5 31.5 31.5	35.5 35.5 35.5
K	□31.4	□34	□40
L	Φ4.5-Φ7.5×5D	Φ5.5-Φ9×6D	Φ5.5-Φ9×6D
ΦL1	Φ66 Φ66 Φ66 Φ66	Φ73 Φ73 Φ73	Φ83 Φ83 Φ83
M	16 16 16 16	18 18 18	22 22 22
N	23.5 23.5 23.5 23.5	26 26 26	30 30 30
Q	Φ15 Φ15 Φ15 Φ15	Φ18 Φ18 Φ18	Φ22 Φ22 Φ22
T	22.5 27.5 35 40	23.5 28.5 36.5	24.5 29.5 38
Y	5 5 5 5	6 6 6	8 8 8
Z	C2 C2 C2 C2	C3 C3 C3	C3 C3 C3
W	11 11 11 11	12 12 12	14 14 14
AA	22 22 22 22	24 24 24	30 30 30
AB	7 7 7 7	8 8 8	9 9 9
ΦAC	Φ24.5	Φ26.5 Φ26.5 Φ26.5	Φ33 Φ33 Φ33
ΦBB	Φ17 Φ17 Φ17	Φ20 Φ20 Φ20	Φ25 Φ25 Φ25
CB	6.5 6.5 6.5 6.5	6.5 6.5 6.5	7.5 7.5 7.5
配管式油口	2-PT1/8	2-PT1/8	2-PT1/8
O型圈(仅G/C型)	2-P5	2-P5	2-P5
推出容积(cm³)	10.9 13.5 17.5 20.2	16.2 20 26	24.2 29.6 38.7
拉入容积(cm³)	7.2 8.9 11.6 13.3	10.8 13.3 17.3	15.8 19.3 25.2

### 规格参数表 SPECIFICATIONS

型号	理论夹持力 (70 kgf/cm²)	转角行程	夹紧行程	总行程	推出容积	拉入容积	推出受压面积	拉入受压面积	使用温度范围	使用流体
MODEL	CLAMPING FORCE AT 70 kgf/cm² (kgf)	SWING STROKE (mm)	CLAMPING STROKE (mm)	TOTAL STROKE(mm)	CYLINDER CAPACITY UNCLAMP(cm³)	CYLINDER CAPACITY CLAMP(cm³)	EFFPISTON AREA UNCLAMP(cm²)	EFFPISTON AREA CLAMP(cm²)	RANGE OF TEMPERATURE(°C)	USABLE FLUID
CHA-036※D	247.8	5.5	8	13.5	6.48	4.78	4.8	3.54	-10~+70°C	相当于ISO粘度等级的ISO-VG-32一般液压油 Recommended: ISO-VG-32 hydraulic oil equivalent to ISO viscosity grade
CHA-040※D	350	6.5	8	14.5	9.29	7.25	6.41	5.0	-10~+70°C	
CHA-048※D	486.5	7.5	8	15.5	14.27	10.77	9.21	6.95	-10~+70°C	
CHA-055※D	721	8.5	10	18.5	25.27	19.06	13.66	10.3	-10~+70°C	
CHA-065※D	938	10	10	20	37.76	26.8	18.88	13.4	-10~+70°C	
CHA-075※D	1421	12	12	24	66.34	48.7	27.64	20.3	-10~+70°C	
CHA-090※D	2065	14	12	26	111.28	76.7	42.8	29.5	-10~+70°C	
CHA-105※D	2891	16	16	32	119.87	132.2	62.46	41.3	-10~+70°C	

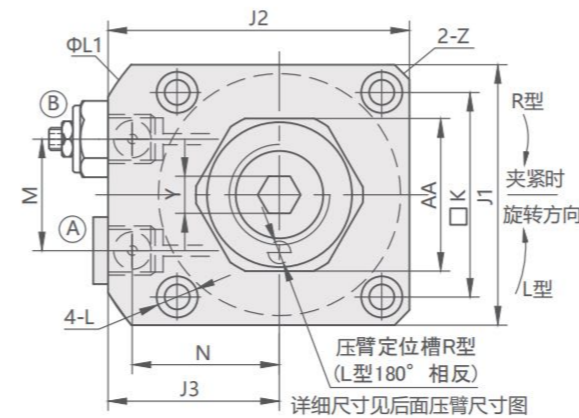

Ⓐ 夹持油孔 Clamping port  
Ⓑ 放松油孔 Unclamping port

Unit:mm

下图表示CHA-\*R-90\*-Q松开状态

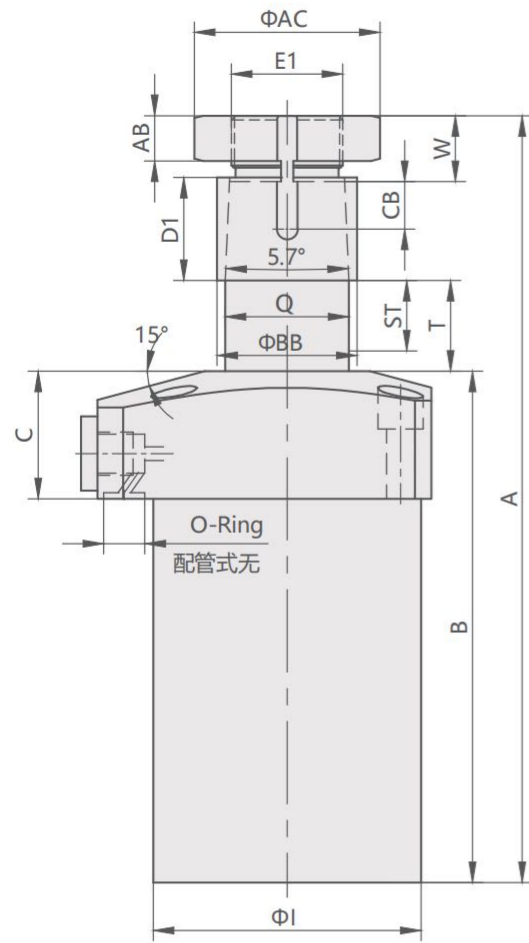

MODEL ITEM	CHA-055□□-Q□	CHA-065□□-Q□	CHA-075□□-Q□	CHA-090□□-Q□
选型	Q15 Q20 Q25	Q15Q20Q25Q30	Q20 Q25	Q20 Q25
ST全行程	23.5 28.5 33.5	25 30 35 40	32 37	34 39
转角行程	8.5 8.5 8.5	10 10 10 10	12 12	14 14
直线行程	15 20 25	15 20 25 30	20 25	20 25
A松开状态	160.5175.5190.5	171 186 201 216	205 220	227 242
B	99 109 119	104 114 124 134	125 135	136 145
C	30 30 30	31 31 31 31	38 38	46 46
D1	22 22 22	25 25 25 25	31 31	38 38
E1	M22×1.5	M27×1.5	M30×1.5	M39×1.5
ΦI	Φ55 Φ55 Φ55	Φ65	Φ75 Φ75	Φ90 Φ90
J1	60 60 60	70 70 70 70	80 80	95 95
J2	69 69 69	81 81 81 81	92 92	107 107
J3	39 39 39	46 46 46 46	52 52	59.5 59.5
K	□47	□55	□63	□75
L	Φ6.8-Φ11×7D	Φ6.8-Φ11×7D	Φ9-Φ14×9D	Φ11-Φ17.5×11D
ΦL1	Φ88	Φ106	Φ116 Φ116	Φ136 Φ136
M	24 24 24	30 30 30 30	32 32	37 37
N	33.5 33.5 33.5	39.5	45 45	52.5 52.5
Q	Φ25 Φ25 Φ25	Φ30 Φ30 Φ30 Φ30	Φ35.5 Φ35.5	Φ45 Φ45
T	25.5 30.5 35.5	27 32 37 42	34 39	36 41
Y	8 8 8	10 10 10 10	10 10	14 14
Z	C3 C3 C3	C4 C4 C4 C4	C5 C5	C6 C6
W	15 15 15	16 16 16 16	16 16	18 18
AA	32 32 32	41 41 41 41	46 46	55 55
AB	10 10 10	11 11 11 11	11 11	12 12
ΦAC	Φ35.5	Φ45	Φ50 Φ50	Φ60 Φ60
ΦBB	Φ28 Φ28 Φ28	Φ34	Φ40 Φ40	Φ49 Φ49
CB	9.5 9.5 9.5	11.5 11.5 11.5 11.5	12.5 12.5	11.5 11.5
配管式油口	2-PT1/8	2-PT1/4	2-PT1/4	2-PT3/8
O型圈(仅G/C型)	2-P5	2-P7	2-P7	2-P7
推出容积(cm³)	35.7 43.3 50.9	51.1 61.3 71.5 81.7	96.6 111.7	154.2 176.9
拉入容积(cm³)	24.2 29.4 34.5	33.5 40.2 46.9 53.6	65 75.1	100.3 115.1

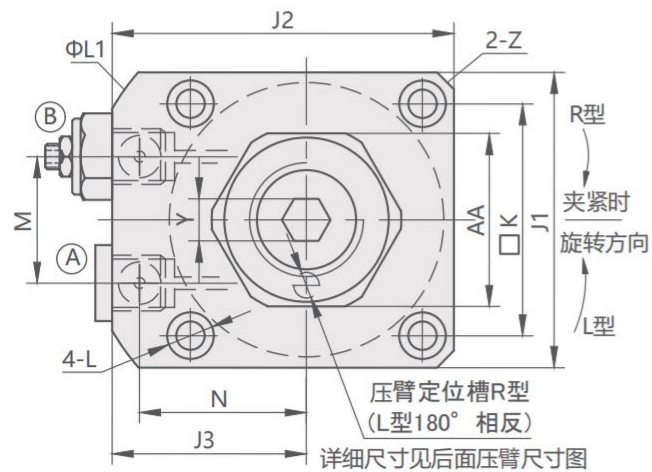

- Ⓐ 夹持油孔 Clamping port  
Ⓑ 放松油孔 Unclamping port

下图表示CHA-\*R-90\*-Q松开状态

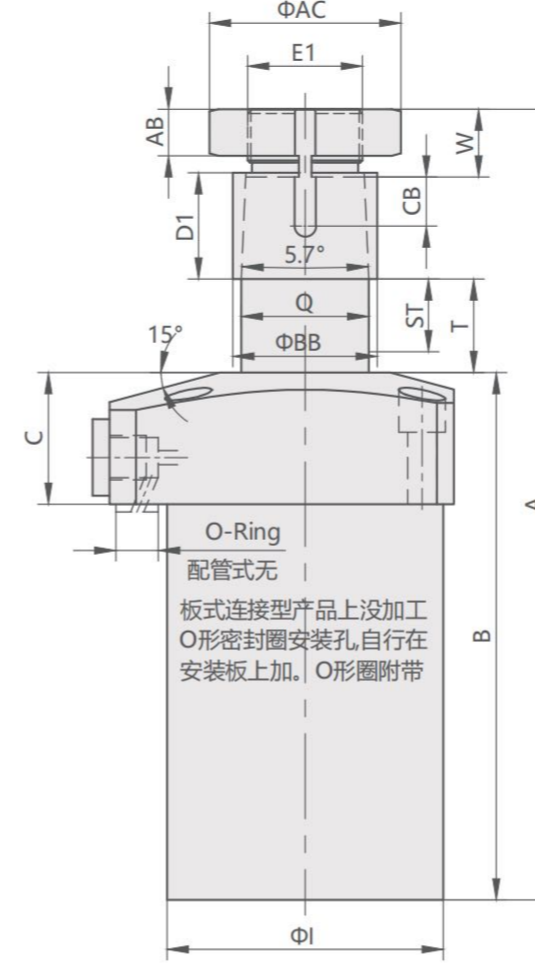

MODEL ITEM	CHA-036□□-Q□	CHA-040□□-Q□	CHA-048□□-Q□
选型	Q35	Q30 Q35 Q40	Q30 Q35 Q40
ST全行程	43	39.5 44.5 49.5	41 46 51
转角行程	8	9.5 9.5 9.5	11 11 11
直线行程	35	30 35 40	30 35 40
A松开状态	192.5	190 205 220	205 220 235
B	123.5	121.5 131.5 141.5	130 140 150
C	25	25 25 25	28 28 28
D1	14	16 16 16	19 19 19
E1	M14×1.5	M16×1.5	M20×1.5
ΦI	Φ36	Φ40 Φ40 Φ40	Φ48 Φ48 Φ48
J1	40	45 45 45	51 51 51
J2	49	54 54 54	61 61 61
J3	29	31.5 31.5 31.5	35.5 35.5 35.5
K	□31.4	□34 □34 □34	□40 □40 □40
L	Φ4.5-Φ7.5×5D	Φ5.5-Φ9×6D	Φ5.5-Φ9×6D
ΦL1	Φ66	Φ73 Φ73 Φ73	Φ83 Φ83 Φ83
M	16	18 18 18	22 22 22
N	23.5	26 26 26	30 30 30
Q	Φ15	Φ18 Φ18 Φ18	Φ22 Φ22 Φ22
T	45	41.5 46.5 51.5	43 48 53
Y	5	6 6 6	8 8 8
Z	C2	C3 C3 C3	C3 C3 C3
W	11	12 12 12	14 14 14
AA	22	24 24 24	30 30 30
AB	7	8 8 8	9 9 9
ΦAC	Φ24.5	Φ26.5 Φ26.5 Φ26.5	Φ33 Φ33 Φ33
ΦBB	Φ17	Φ20 Φ20 Φ20	Φ25 Φ25 Φ25
CB	6.5	6.5 6.5 6.5	7.5 7.5 7.5
配管式油口	2-PT1/8	2-PT1/8	2-PT1/8
O型圈(仅G/C型)	2-P5	2-P5	2-P5
推出容积(cm³)	22.8	29.8 22.3 24.8	28.7 32 35.7
拉入容积(cm³)	15.1	19.8 22.3 24.8	28.7 32 35.7

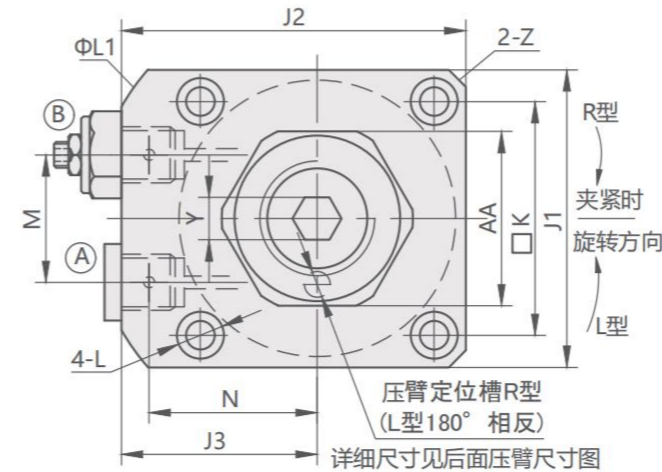

- Ⓐ 夹持油孔 Clamping port  
Ⓑ 放松油孔 Unclamping port

下图表示CHA-\*R-90\*-Q松开状态

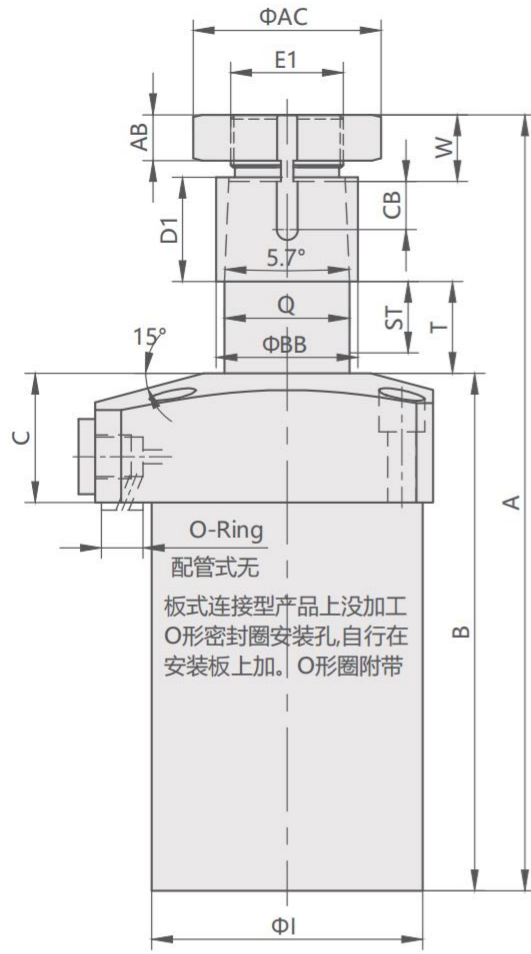

MODEL ITEM	CHA-055□□-Q□					CHA-065□□-Q□					CHA-075□□-Q□				
选型	Q30	Q35	Q40	Q45	Q50	Q35	Q40	Q45	Q50	Q30	Q35	Q40	Q45	Q50	
ST全行程	42	47	52	57	62	50	55	60	65	42	47	55	60	65	
转角行程	12	12	12	12	12	15	15	15	15	12	12	15	15	15	
直线行程	30	35	40	45	50	35	40	45	50	30	35	40	45	50	
A松开状态	216	231	246	261	276	246	261	276	291	235	250	274	289	304	
B	136	146	156	166	176	154	164	174	184	145	155	171	181	191	
C	30	30	30	30	30	31	31	31	31	38	38	38	38	38	
D1	22	22	22	22	22	25	25	25	25	31	31	31	31	31	
E1	M22×1.5					M27×1.5					M30×1.5				
ΦI	Φ55Φ55Φ55Φ55Φ55					Φ65Φ65Φ65Φ65Φ65					Φ75Φ75Φ75Φ75Φ75				
J1	60	60	60	60	60	70	70	70	70	80	80	80	80	80	
J2	69	69	69	69	69	81	81	81	81	92	92	92	92	92	
J3	39	39	39	39	39	46	46	46	46	52	52	52	52	52	
K	□47					□55					□63				
L	Φ6.8-Φ11×7D					Φ6.8-Φ11×7D					Φ9-Φ14×9D				
ΦL1	Φ88Φ88Φ88Φ88Φ88					Φ106Φ106Φ106Φ106Φ106					Φ116				
M	24	24	24	24	24	30	30	30	30	32	32	32	32	32	
N	33.5	33.5	33.5	33.5	33.5	39.5	39.5	39.5	39.5	45	45	45	45	45	
Q	Φ25Φ25Φ25Φ25Φ25					Φ30Φ30Φ30Φ30Φ30					Φ35.5				
T	44	49	54	59	64	52	57	62	67	44	49	57	62	67	
Y	8	8	8	8	8	10	10	10	10	10	10	10	10	10	
Z	C3	C3	C3	C3	C3	C4	C4	C4	C4	C5	C5	C5	C5	C5	
W	15	15	15	15	15	16	16	16	16	16	16	16	16	16	
AA	32	32	32	32	32	41	41	41	41	46	46	46	46	46	
AB	10	10	10	10	10	11	11	11	11	11	11	11	11	11	
ΦAC	Φ35.5					Φ45Φ45Φ45Φ45Φ45					Φ50Φ50Φ50Φ50Φ50				
ΦBB	Φ28Φ28Φ28Φ28Φ28					Φ34Φ34Φ34Φ34Φ34					Φ40Φ40Φ40Φ40Φ40				
CB	9.5	9.5	9.5	9.5	9.5	11.5	11.5	11.5	11.5	12.5	12.5	12.5	12.5	12.5	
配管式油口	2-PT1/8					2-PT1/4					2-PT1/4				
O型圈(仅G/C型)	2-P5					2-P7					2-P7				
推出容积(cm³)	63.9	71.5	79.1	86.7	94.3	102.1	112.3	122.6	132.7	126.8	141.9	166	181.1	196.2	
拉入容积(cm³)	43.3	48.4	53.6	58.7	63.9	67	73.7	80.4	87.1	85.3	95.4	117	121.8	132	

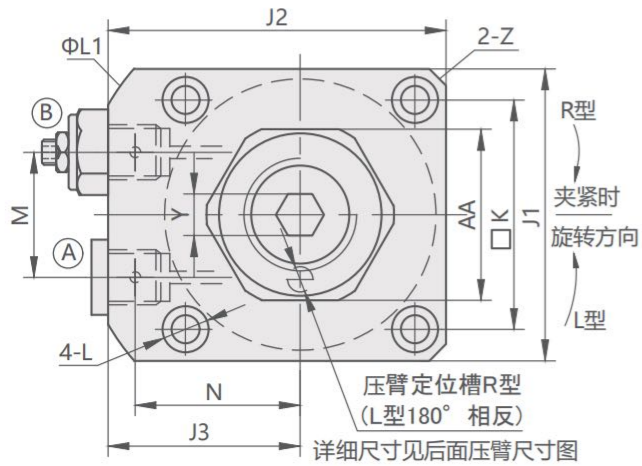

- Ⓐ 夹持油孔 Clamping port
- Ⓑ 放松油孔 Unclamping port

下图表示CHA-\*R-90\*-Q松开状态

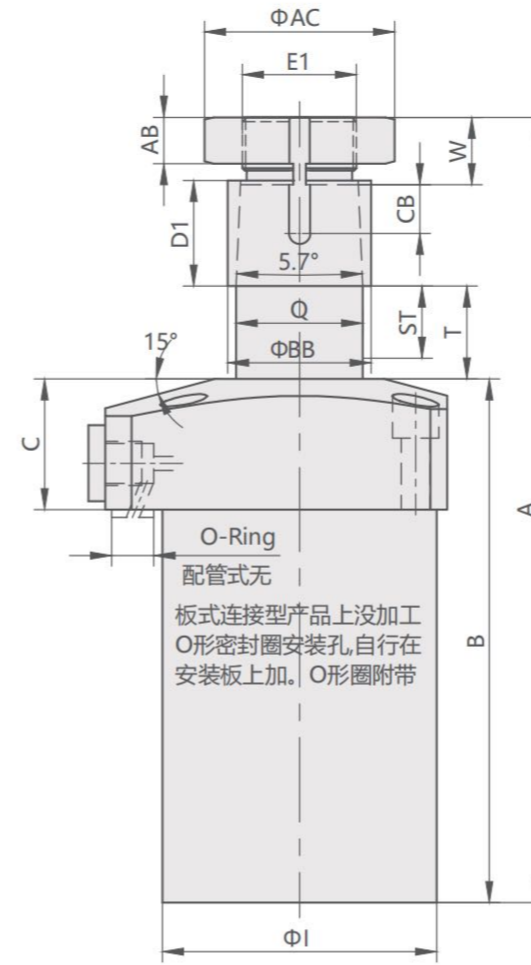

MODEL ITEM	CHA-090□□-Q□					CHA-0105□□-Q□					
选型	Q30	Q35	Q40	Q45	Q50	Q25	Q30	Q35	Q40	Q45	Q50
ST全行程	44	49	57	62	67	41	46	51	56	61	66
转角行程	14	14	17	17	17	17	16	16	16	16	16
直线行程	30	35	40	45	50	25	30	35	40	45	50
A松开状态	257	272	296	311	326	267	282	297	312	327	342
B	156	166	182	192	202	162	172	182	192	202	212
C	46	46	46	46	46	56	56	56	56	56	56
D1	38	38	38	38	38	44	44	44	44	44	44
E1	M39×1.5					M48×1.5					
ΦI	Φ90Φ90Φ90Φ90Φ90					Φ105Φ105Φ105Φ105Φ105					
J1	95	95	95	95	95	110	110	110	110	110	110
J2	107	107	107	107	107	122	122	122	122	122	122
J3	59.5	59.5	59.5	59.5	59.5	67	67	67	67	67	67
K	□75	□75	□75	□75	□75	□88	□88	□88	□88	□88	□88
L	Φ11-Φ17.5×11D					Φ14-Φ20×14D					
ΦL1	Φ136Φ136Φ136Φ136Φ136					Φ152Φ152Φ152Φ152Φ152					
M	37	37	37	37	37	45	45	45	45	45	45
N	52.5	52.5	52.5	52.5	52.5	60	60	60	60	60	60
Q	Φ45Φ45Φ45Φ45Φ45					Φ55Φ55Φ55Φ55Φ55					
T	46	51	59	64	69	43	48	53	58	63	68
Y	14	14	14	14	14	14	14	14	14	14	14
Z	C6	C6	C6	C6	C6	C6	C6	C6	C6	C6	C6
W	18	18	18	18	18	19	19	19	19	19	19
AA	55	55	55	55	55	65	65	65	65	65	65
AB	12	12	12	12	12	12	12	12	12	12	12
ΦAC	Φ60Φ60Φ60Φ60Φ60					Φ71Φ71Φ71Φ71Φ71					
ΦBB	Φ49Φ49Φ49Φ49Φ49					Φ60Φ60Φ60Φ60Φ60					
CB	11.5	11.5	11.5	11.5	11.5	13.5	13.5	13.5	13.5	13.5	13.5
配管式油口	2-PT3/8					2-PT3/8					
O型圈(仅G/C型)	2-P7					2-P7					
推出容积(cm³)	199.6	222.3	258.6	281.3	303.9	266.7	299.2	331.7	364.2	396.7	429.3
拉入容积(cm³)	129.8	144.4	168.2	182.9	197.7	169.3	190	210.6	231.3	251.9	272.6

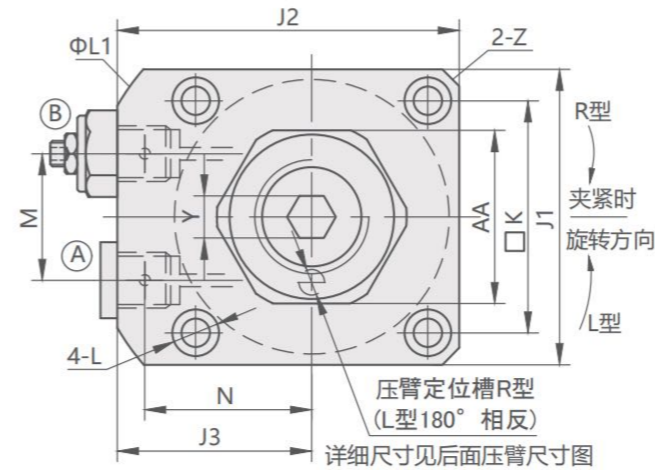

- Ⓐ 夹持油孔 Clamping port
- Ⓑ 放松油孔 Unclamping port

# CLHW

## 传感器内置式转角缸

## CLHW AIR SENSING SWING CLAMP



### 产品特性

此系列产品动作端内置有动作确认机构,最适用于实现设备的自动化。  
通过连接空气传感器,检出压差,实现确认动作。  
通过夹紧动作确认,能实现安全可靠地将工件搬入搬出。  
内置传感阀,可实现超薄型的夹具设计。  
简单的油路孔设计。

最大操作压力: 70kgf/cm<sup>2</sup>  
最小操作压力: 15 kgf/cm<sup>2</sup>

### FEATURES

The CLHW series utilizes air sensing mechanisms by detecting the differential pressure to achieve action confirmation, allowing safe and efficient loading/unloading of the workpiece. With the integration of the built-in sensor valves, the CLHW series has taken a new and improved compact design and is most suitable for achieving automation.

Max.operating pressure: 70kgf/cm<sup>2</sup>  
Min.operating pressure: 15kgf/cm<sup>2</sup>

### 注意事项

夹紧及放松动作速度需适当放缓。为进行确认动作,须设置空气传感器。气口须进行大气开放,务必防止冷却液,切削渣的侵入。使用时请保持向气口常态供气状态。

### NOTE

The speed of clamping and unclamping action needs to be slowed down appropriately. Action confirmation can be conducted by detecting differential pressure with the air sensor. Please keep clearance of the air exhaust hole to prevent the intrusion of coolant and chips. Make sure to supply constant air pressure to the air port when in use.

### 订购标示法 ORDERING INDICATION

#### 示例: CLHW-048CRE

CLHW	系列 Series	CLHW		
048	主体尺寸 Body size	040: ΦD=40mm 048: ΦD=48mm 055: ΦD=55mm	065: ΦD=65mm 075: ΦD=75mm	ΦD表示本体油缸外径尺寸 Outer diameter (ΦD) of the cylinder
C	板式连接型(附带G螺纹堵头) Gasket Option(With G Thread Plug)	附带G螺纹堵头可安装速度控制阀(CZL)(用户另行购买) With G Thread Plug (able to attach Speed Control Valve) (Order the valve separately. Recommended:CZL)		
R	夹紧时的旋转方向 Swing Direction When Clamping	R: 顺时针方向 L: 逆时针方向	R: Clockwise L: Counter-Clockwise	
E	传感阀符号 Sensing Valve	E: 夹紧释放动作确认型 H: 夹紧动作确认型 J: 释放动作确认型	E: Clamp-Unclamp Confirmation(Both) H: Clamp Confirmation Only J:Unclamp Confirmation Only	

注: 推荐使用气缸0.1-0.2MPa,空气传感器为SMC的ISA2-HE45N。  
Note: Recommended Operating Air Pressure 0.1~0.2MPa. Air Sensor: ISA2-HE45N(SMC)

### 传感器内置式旋转缸 AIR SENSING SWING CLAMP

动作原理(剖面结构)

※本图表示夹紧、释放动作确认型(Model CLHW-CDE)

#### 夹紧

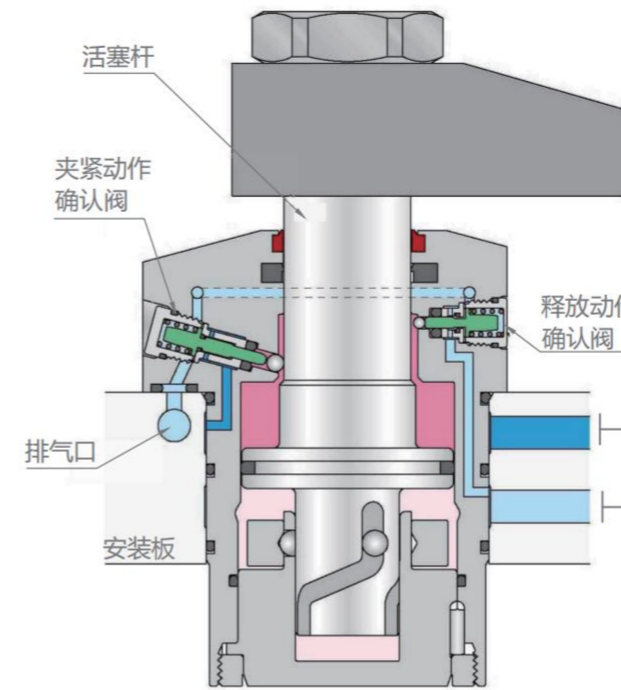

#### 释放

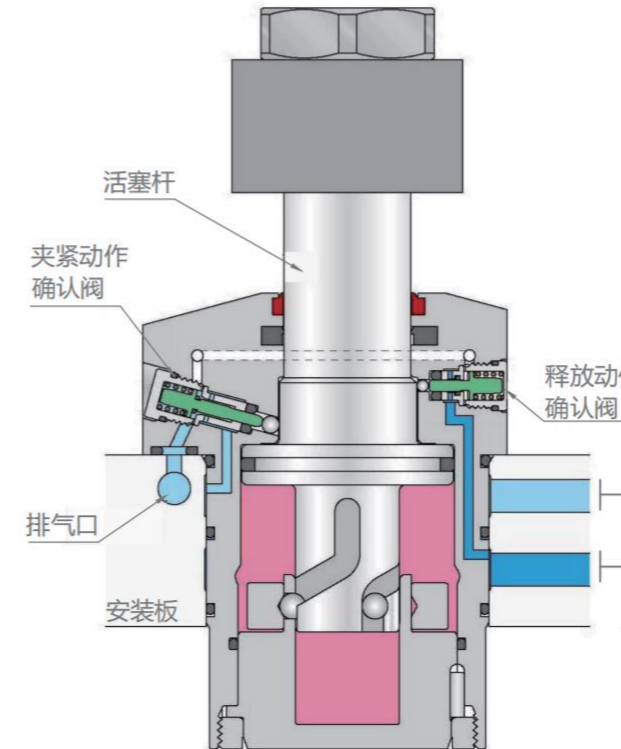

夹紧(向夹紧用供油口供给油压时)

活塞杆边下降边进行旋转动作。

活塞杆旋转动作结束后,垂直下降夹紧工件。

油压		空气传感器	
夹紧油压	释放油压	夹紧动作确认	释放动作确认
ON	OFF	ON	OFF

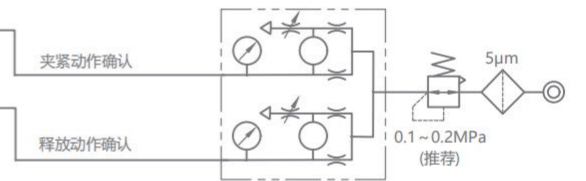
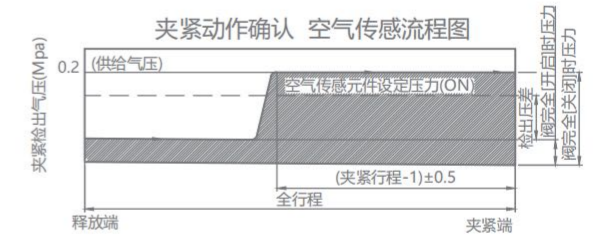

空气传感器  
(根据传感器的不同回路图也有不同)

释放(向释放用供油口供给油压时)

活塞杆垂直上升。(夹紧行程范围)

垂直动作结束后,活塞杆边旋转边上升。

油压		空气传感器	
夹紧油压	释放油压	夹紧动作确认	释放动作确认
OFF	ON	OFF	ON

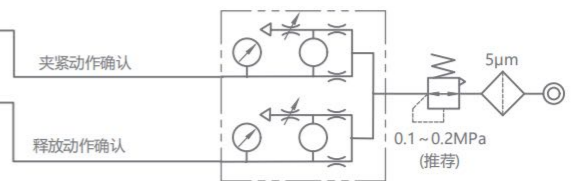
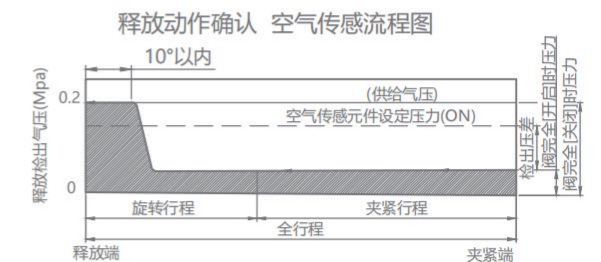

空气传感器  
(根据传感器的不同回路图也有不同)

## 夹紧·释放动作确认型 CLAMP-UNCLAMP CONFIRMATION

※本图表示CLHW-CRE的释放状态  
The drawing shows the unclamped state of CLHW-CRE

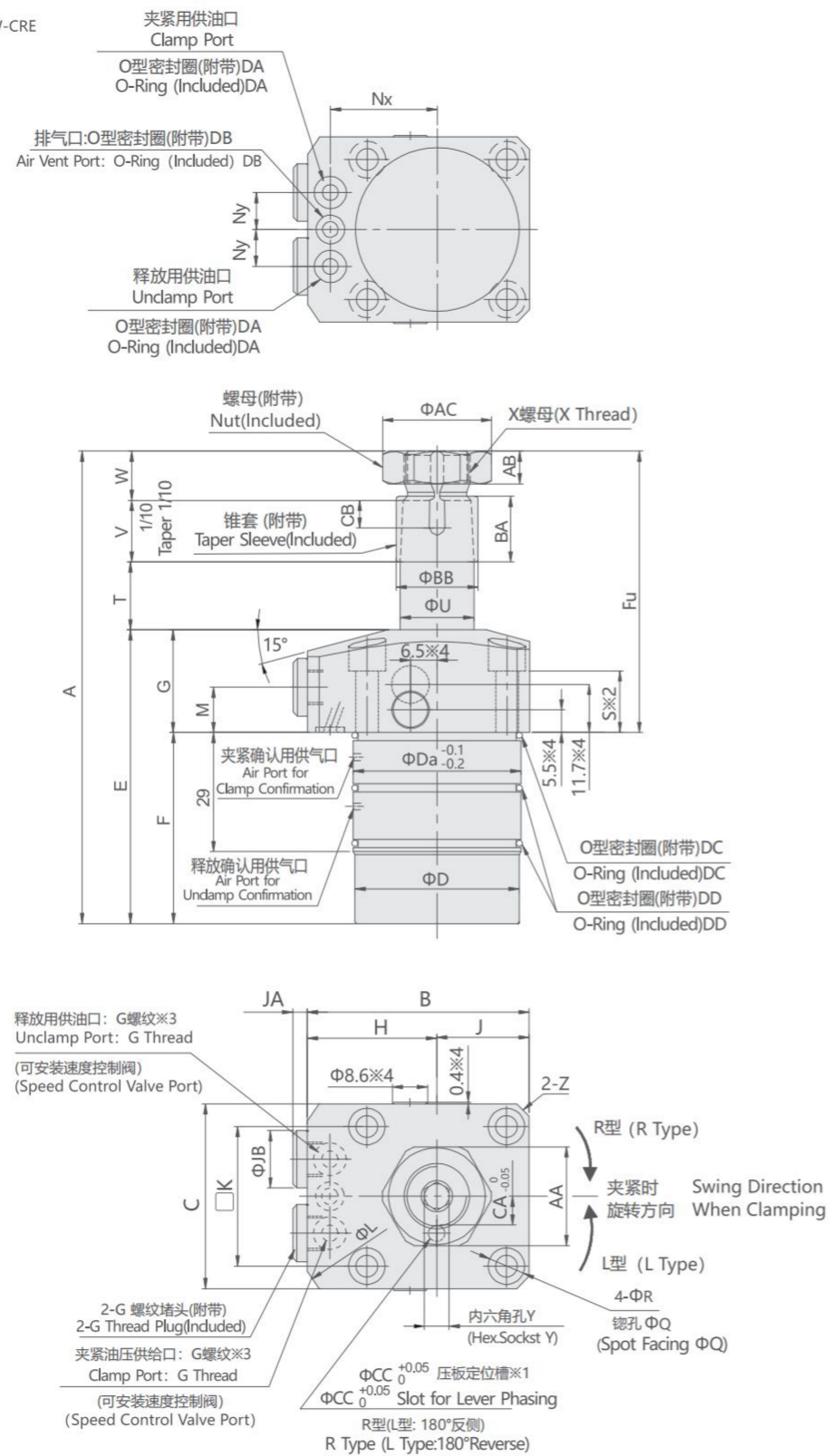

### 注意事项

- ※1.压板定位槽在夹紧时朝向供油口侧。
- ※2.本产品未附带安装螺栓。
- ※3.本产品未附带速度控制阀，请用户自行配备。
- ※4.仅有CLHW-040如记载尺寸，传感阀是从本体凸出来的。

### NOTE

- ※1.The slot for lever phasing faces the port side when clamped.
- ※2.Mounting bolts are not provided . Please prepare them according to the mounting height referring to dimension "S".
- ※3.Speed control valve is sold separately.
- ※4.The valve of CLHW-040 is protruded as shown in the drawing.

## 安装部位加工尺寸 Machining Dimensions of Mounting Area

Unit:mm

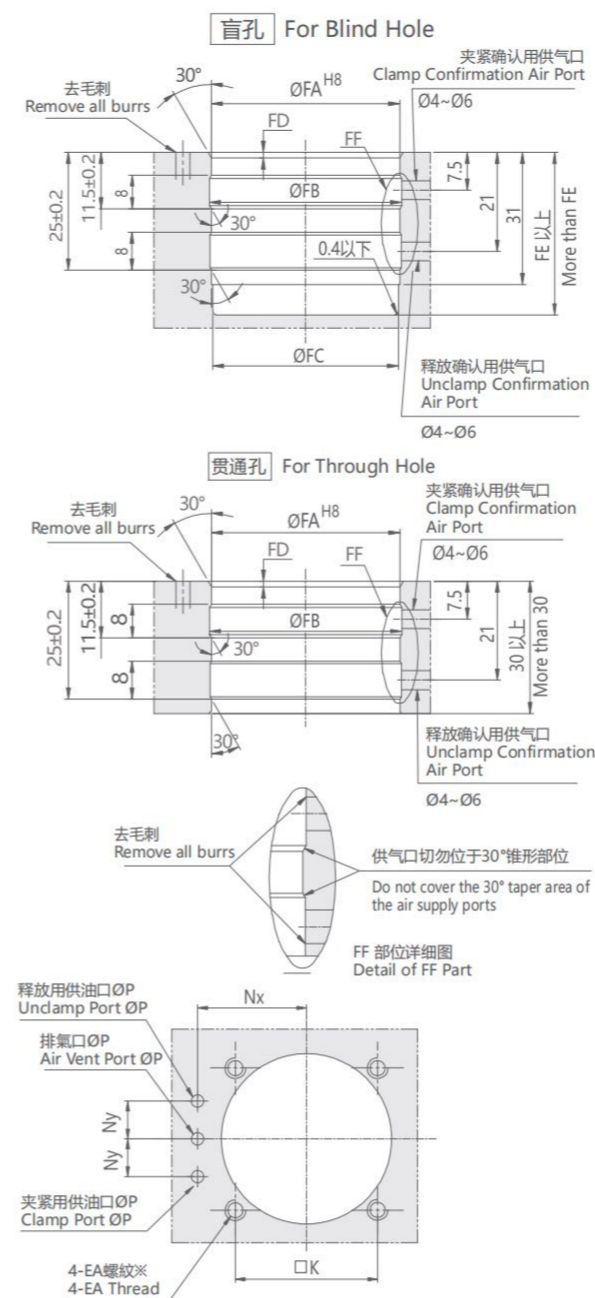

### 注意事项

※请参考S尺寸并根据安装高度决定安装螺栓的EA螺纹孔的深度。

### NOTE

※EA tapping depth the mounting bolt should be decided according to the mounting height referring to dimension "S".

MODEL ITEM	CLHW-040C□E	CLHW-048C□E	CLHW-055C□E	CLHW-065C□E	CLHW-075C□E
A	115	128.5	145.5	156	181
B	54	61	69	81	92
C	45	51	60	70	80
D	40	48	55	65	75
Da	40.8	49	56	66	76
E	71.5	79	89	94	109
F	46.5	51	59	63	71
Fu	68.5	77.5	86.5	93	110
G	25	28	30	31	38
H	31.5	35.5	39	46	52
J	22.5	25.5	30	35	40
K	34	40	47	55	63
L	73	83	88	106	116
M	11	13	12	13	16
Nx	26	30	33.5	39.5	45
Ny	9	11	12	15	16
P	3	3	3	5	5
Q	9	9	11	11	14
R	5.5	5.5	6.8	6.8	9
S	15	17.5	17	17	21
T	16.5	17.5	20.5	22	26
U	18	22	25	30	35.5
V	15	18	21	24	30
W	12	14	15	16	16
X(名称X螺距)	M16x1.5	M20x1.5	M22x1.5	M27x1.5	M30x1.5
Y	6	8	8	10	10
z(倒角)	C3	C3	C3	C4	C5
AA	24	30	32	41	46
AB	8	9	10	11	11
AC	26.5	33	35.5	45	50
BA	16	19	22	25	31
BB	20	25	28	34	40
CA	7	9	10	12.5	14
CB	6.5	7.5	9.5	11.5	12.5
CC	4	5	6	6	8
EA	M5x0.8	M5x0.8	M6	M6	M8
FA	40.8 <sup>+0.04</sup> <sub>0</sub>	49 <sup>+0.04</sup> <sub>0</sub>	56 <sup>+0.04</sup> <sub>0</sub>	66 <sup>+0.04</sup> <sub>0</sub>	76 <sup>+0.04</sup> <sub>0</sub>
FB	41.4	49.6	56.6	66.6	76.6
FC	40.5	48.5	55.5	65.5	75.5
FD	1.2	1.2	1.5	1.5	1.5
FE	47	51.5	59.5	63.5	71.5
JA	4	4	4	4.5	4.5
JB	14	14	14	19	19
夹紧用供油口: G螺纹 (Clamp Port: G Thread)	G1/8	G1/8	G1/8	G1/4	G1/4
释放用供油口: G螺纹 (Unclamp Port: G Thread)	G1/8	G1/8	G1/8	G1/4	G1/4
O型密封圈 (O-Ring)	DA AS568-007(90°)	DB 1BP5	DC 1BP5	DD 1BP5	1BP7
	38x1.5(内径×线径)	AS568-031(70°)	AS568-034(70°)	AS568-037(70°)	AS568-040(70°)
	38x1.5(内径×线径)	AS568-031(70°)	AS568-033(70°)	AS568-036(70°)	AS568-040(70°)

## 规格参数表 SPECIFICATIONS

型号	理论支持力 (70 kgf/cm²)	转角行程	夹紧行程	总行程	推出容积	拉入容积	推出受压面积	拉入受压面积	使用温度范围
MODEL	CLAMPING FORCE AT 70 kgf/cm² (kgf)	SWING STROKE (mm)	CLAMPING STROKE (mm)	TOTAL STROKE(mm)	CYLINDER CAPACITY CLAMP(cm³)	CYLINDER CAPACITY UNCLAMP(cm³)	EFF.PISTON AREA CLAMP(cm²)	EFF.PISTON AREA UNCLAMP(cm²)	RANGE OF TEMPERATURE(°C)
CLHW-040	350	6.5	8	14.5	10.9	7.3	7.54	5.0	0-+70°C
CLHW-048	486.5	7.5	8	15.5	16.7	10.8	10.75	6.95	0-+70°C
CLHW-055	721	8.5	10	18.5	28.1	19	15.2	10.3	0-+70°C
CLHW-065	938	10	10	20	40.9	26.7	20.42	13.4	0-+70°C
CLHW-075	1421	12	12	24	72.5	48.7	30.18	20.3	0-+70°C

**夹紧动作确认型  
CLAMP CONFIRMATION ONLY**

※本图表示CLHW-CRH的夹紧状态  
The drawing shows the clamped state of CLHW-CRH

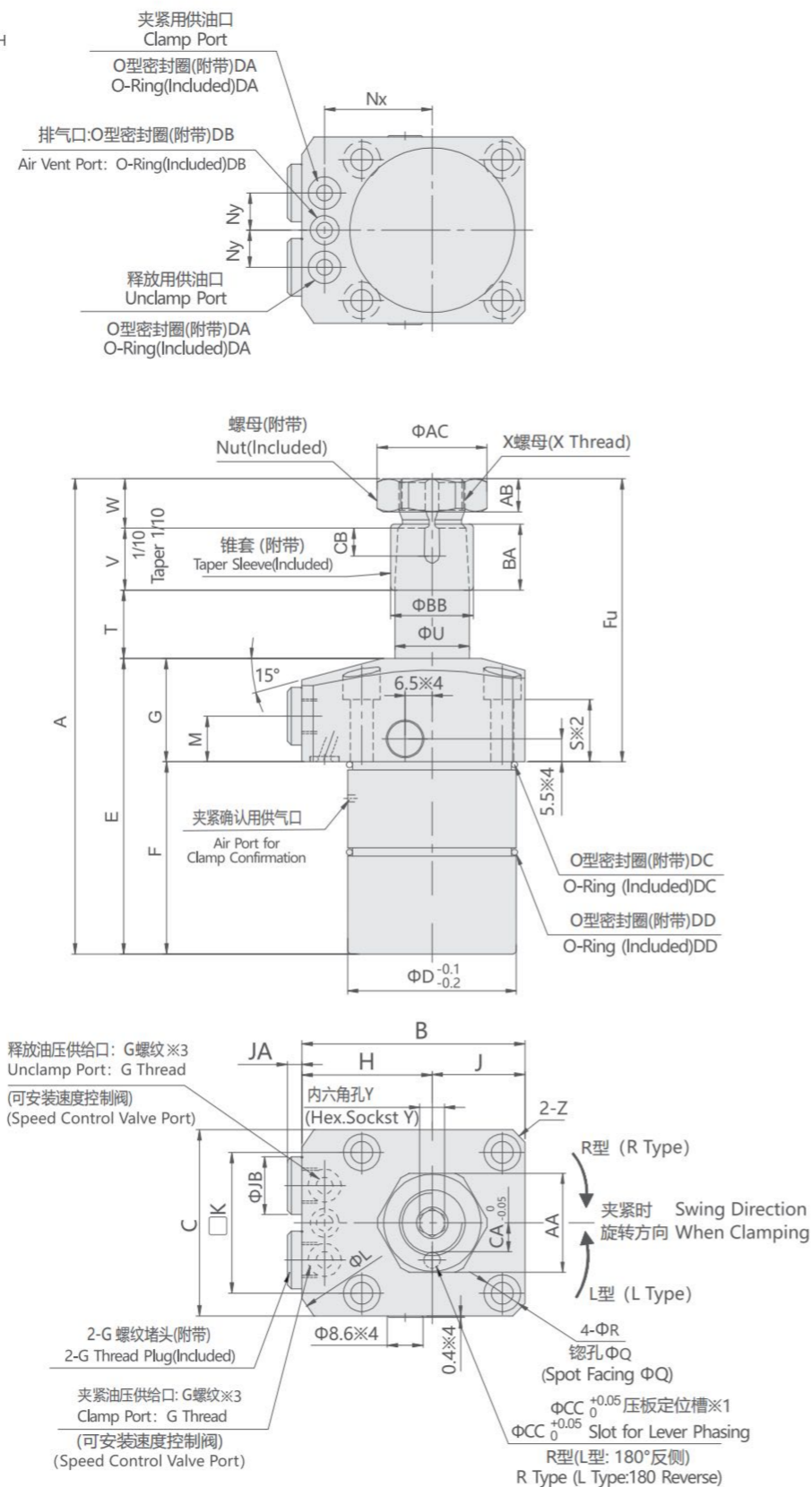

**NOTE**

- ※1.The slot for lever phasing faces the port side when clamped.
- ※2.Mounting bolts are not provided,Please prepare them according to the mounting height referring to dimension"S".
- ※3.Speed control valve is sold separately.
- ※4.The valve of CLHW-040 is protruded as shown in the drawing.

**安装部位加工尺寸  
MACHINING DIMENSIONS OF MOUNTING AREA**

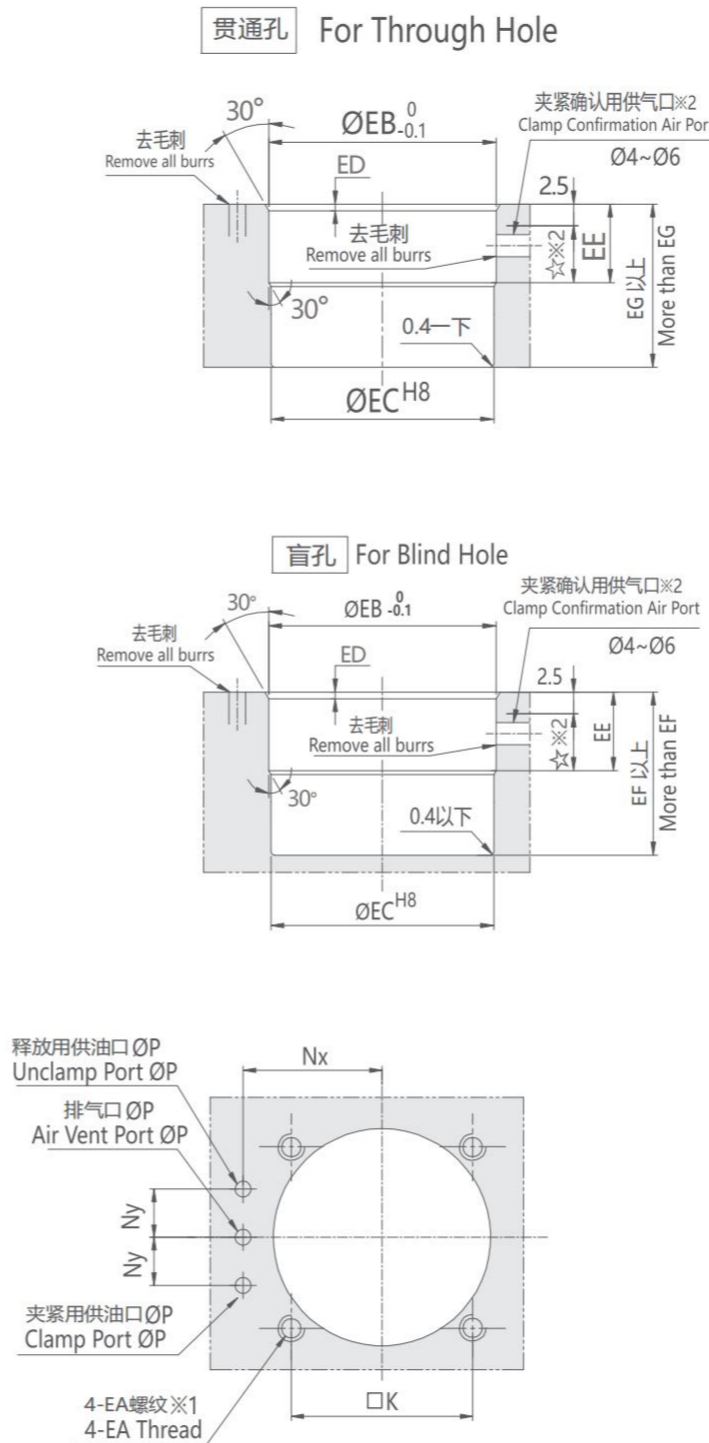

**注意事项**

- ※1.请参考S尺寸并根据安装高度决定安装螺栓的EA螺纹孔的深度。
- ※2.请将夹紧确认用供气口设置于图示☆范围内。

MODEL ITEM	CLHW-040C□H	CLHW-048C□H	CLHW-055C□H	CLHW-065C□H	CLHW-075C□H
A	115	128.5	145.5	156	181
B	54	61	69	81	92
C	45	51	60	70	80
D	40	48	55	65	75
E	71.5	79	89	94	109
F	46.5	51	59	63	71
Fu	68.5	77.5	86.5	93	110
G	25	28	30	31	38
H	31.5	35.5	39	46	52
J	22.5	25.5	30	35	40
K	34	40	47	55	63
L	73	83	88	106	116
M	11	13	12	13	16
Nx	26	30	33.5	39.5	45
Ny	9	11	12	15	16
P	3	3	3	5	5
Q	9	9	11	11	14
R	5.5	5.5	6.8	6.8	9
S	15	17.5	17	17	21
T	16.5	17.5	20.5	22	26
U	18	22	25	30	35.5
V	15	18	21	24	30
W	12	14	15	16	16
X(名称X螺距)	M16×1.5	M20×1.5	M22×1.5	M27×1.5	M30×1.5
Y	6	8	8	10	10
Z(倒角)	C3	C3	C3	C4	C5
AA	24	30	32	41	46
AB	8	9	10	11	11
AC	26.5	33	35.5	45	50
BA	16	19	22	25	31
BB	20	25	28	34	40
CA	7	9	10	12.5	14
CB	6.5	7.5	9.5	11.5	12.5
CC	4	5	6	6	8
EA	M5x0.8	M5x0.8	M6	M6	M8
EB	40.8	49	56	66	76
EC	40 <sup>+0.04</sup> <sub>0</sub>	48 <sup>+0.04</sup> <sub>0</sub>	55 <sup>+0.04</sup> <sub>0</sub>	65 <sup>+0.04</sup> <sub>0</sub>	75 <sup>+0.04</sup> <sub>0</sub>
ED	1.2	1.2	1.5	1.5	1.5
EE	20	20	24	24	34
EF	47	51.5	59.5	63.5	71.5
EG	26	26	30	30	40
JA	4	4	3.5	4.5	4.5
JB	14	14	14	19	19
夹紧用供油口:G螺纹 Clamp Port: G Thread	G1/8	G1/8	G1/8	G1/4	G1/4
释放用供油口:G螺纹 Unclamp Port: G Thread	DA	1BP5	1BP5	1BP5	1BP7
O型密封圈 O-Ring	DB	AS568-007(90°)	1BP5	1BP5	1BP7
DC	38x1.5(内径×线径)	AS568-031(70°)	AS568-034(70°)	AS568-037(70°)	AS568-040(70°)
DD	AS568-028(70°)	AS568-031(70°)	AS568-033(70°)	AS568-036(70°)	AS568-039(70°)

**NOTE**

- ※1.EA tapping depth of the mounting bolt should be decided according to the mounting height referring to dimension"S".
- ※2. Provide the air port for clamp confirmation within the part☆.

**释放动作确认型  
UNCLAMP CONFIRMATION ONLY**

※本图表示CLHW-CRJ的释放状态  
The drawing shows the unclamped state of CLHW-CRJ

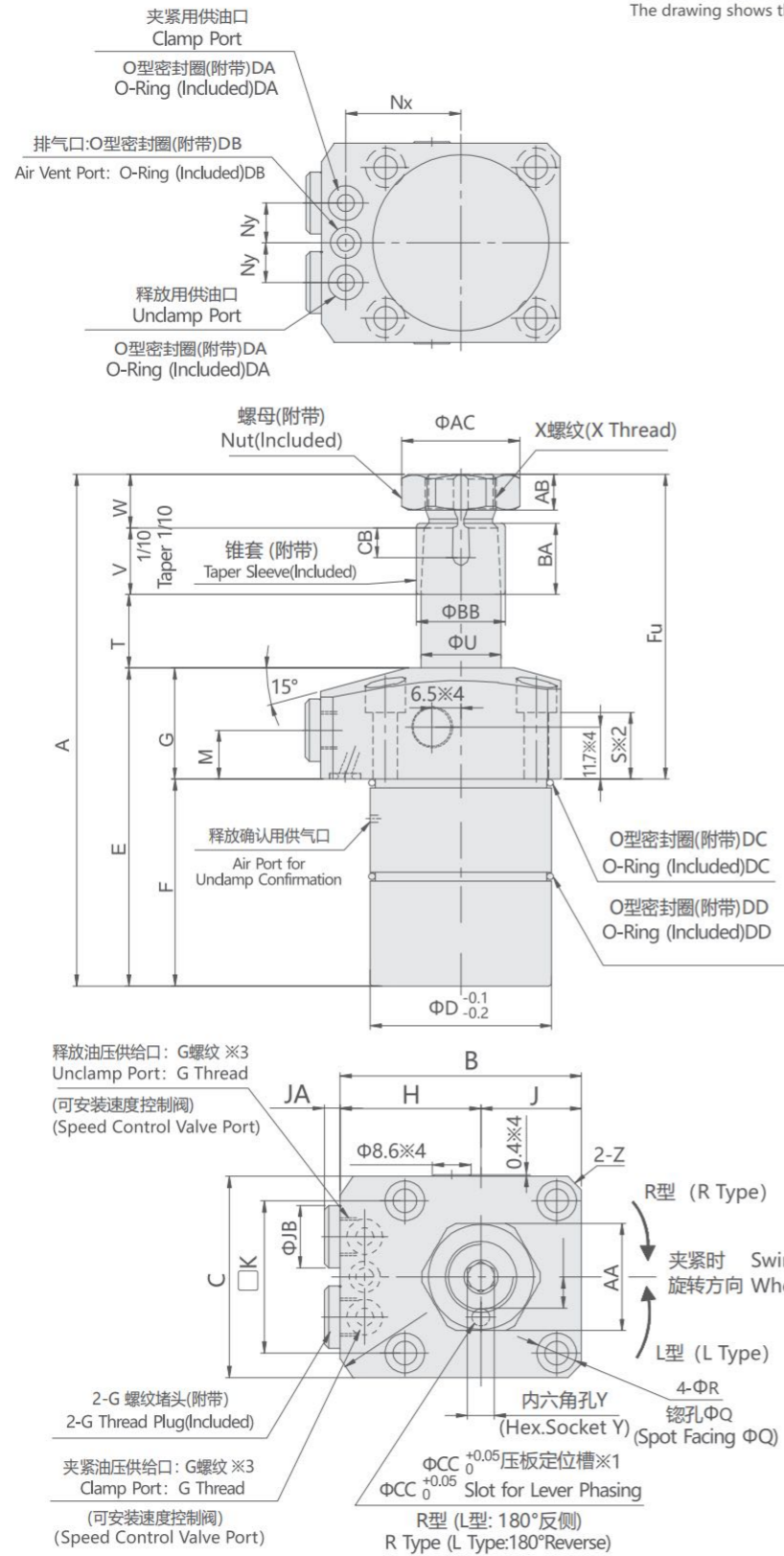

**注意事项**

- ※1.压板定位槽在夹紧时朝向供油口侧。
- ※2.本产品未附带安装螺栓。请用户参考S尺寸并根据安装高度自行配备。
- ※3.本产品未附带速度控制阀，请用户自行配备。
- ※4.仅有CLHW-040如记载尺寸，传感阀是从本体凸出来的。

**NOTE**

- ※1.The slot for lever phasing faces the port side when clamped.
- ※2.Mounting bolts are not provided. Please prepare them according to the mounting height referring to dimension "S".
- ※3.Speed control valve is sold separately.
- ※4.The valve of CLHW-040 is protruded as shown in the drawing.

**安装部位加工尺寸  
MACHINING DIMENSIONS OF MOUNTING AREA**

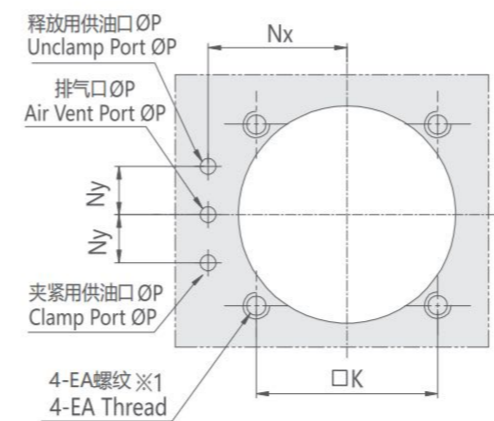
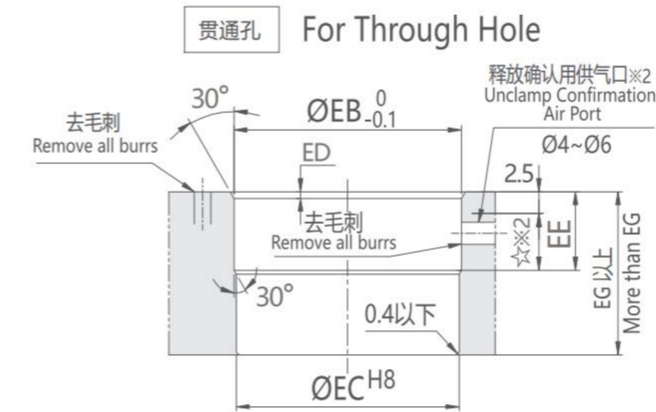
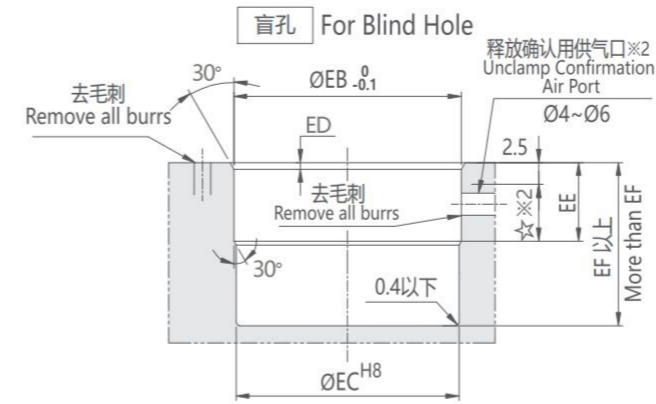

**注意事项**

- ※1.请参考S尺寸并根据安装高度决定安装螺栓的EA螺纹孔的深度。
- ※2.请将释放确认用供气口设置于图示☆\*2范围内。

**NOTE**

- ※1.EA tapping depth of the mounting bolt should be decided according to the mounting height referring to dimensions "S".
- ※2. Provide the air port for unclamp confirmation within the part ☆.

Unit:mm

MODEL ITEM	CLHW-040□J	CLHW-048□J	CLHW-055□J	CLHW-065□J	CLHW-075□J
A	115	128.5	145.5	156	181
B	54	61	69	81	92
C	45	51	60	70	80
D	40	48	55	65	75
E	71.5	79	89	94	109
F	46.5	51	59	63	71
Fu	68.5	77.5	86.5	93	110
G	25	28	30	31	38
H	31.5	35.5	39	46	52
J	22.5	25.5	30	35	40
K	34	40	47	55	63
L	73	83	88	106	116
M	11	13	12	13	16
Nx	26	30	33.5	39.5	45
Ny	9	11	12	15	16
P	3	3	3	5	5
Q	9	9	11	11	14
R	5.5	5.5	6.8	6.8	9
S	15	17.5	17	17	21
T	16.5	17.5	20.5	22	26
U	18	22	25	30	35.5
V	15	18	21	24	30
W	12	14	15	16	16
X(名称X螺距)	M16x1.5	M20x1.5	M22x1.5	M27x1.5	M30x1.5
Y	6	8	8	10	10
Z(倒角)	C3	C3	C3	C4	C5
AA	24	30	32	41	46
AB	8	9	10	11	11
AC	26.5	33	35.5	45	50
BA	16	19	22	25	31
BB	20	25	28	34	40
CA	7	9	10	12.5	14
CB	6.5	7.5	9.5	11.5	12.5
CC	4	5	6	6	8
EA	M5x0.8	M5x0.8	M6	M6	M8
EB	40.8	49	56	66	76
EC	40 <sup>+0.04</sup>	48 <sup>+0.04</sup>	55 <sup>+0.04</sup>	65 <sup>+0.04</sup>	75 <sup>+0.04</sup>
ED	1.2	1.2	1.5	1.5	1.5
EE	20	20	24	24	34
EF	47	51.5	59.5	63.5	71.5
EG	26	26	30	30	40
JA	4	4	4	4.5	4.5
JB	14	14	14	19	19
夹紧用供油口: G螺纹 Clamp Port :G Thread	G1/8	G1/8	G1/8	G1/4	G1/4
释放用供油口: G螺纹 Unclamp Port :G Thread					
O型密封圈 O-Ring	DA 1BP5	1BP5	1BP5	1BP7	1BP7
DB	AS568-007(90°)	1BP5	1BP5	1BP7	1BP7
DC	38x1.5(内径x线径)	AS568-031(70°)	AS568-034(70°)	AS568-037(70°)	AS568-040(70°)
DD	AS568-028(70°)	AS568-031(70°)	AS568-033(70°)	AS568-036(70°)	AS568-039(70°)

# CHA-P

## 油压转角缸

# CHA-P HYDRAULIC SWING CLAMP



### 产品特性

此系列产品配件采用优化设计,使体积更加紧凑,提高了产品强度。产品采用了专用防尘设计,提高了防尘和密封性,实现了高密封性。产品结构具有高抗扭性,实现了高耐久性。

最大操作压力: 70 kgf/cm<sup>2</sup>  
 最小操作压力: 15 kgf/cm<sup>2</sup>  
 作动方式: 复动式

### 注意事项

夹紧及放松作动速度需适当放缓。压臂安装拆卸方式,请参见第4页。可接受订制,欢迎与本公司洽询。

### FEATURES

The accessories of the CHA-P series are optimally designed to create a more compact-sized product with enhanced strength. With its special dust-proof design, this product has improved its sealing performance and protects against any particles or debris while in use. The product's structure design has a high torsion resistance that achieves maximum durability.

Max. operating pressure : 70 kgf/cm<sup>2</sup>  
 Min. operating pressure : 15 kgf/cm<sup>2</sup>  
 Double acting

### NOTE

The action and the speed of clamping / unclamping needs to be slowed down appropriately. Please refer to Page 4 for installation instructions or removal methods of the clamping arm. Customization is available upon request, please contact us for more info.

### 剖面图 Sectional view

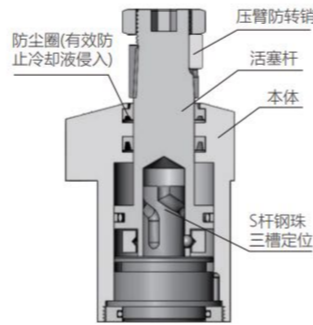

### SINGLE SIDE SWING CLAMP

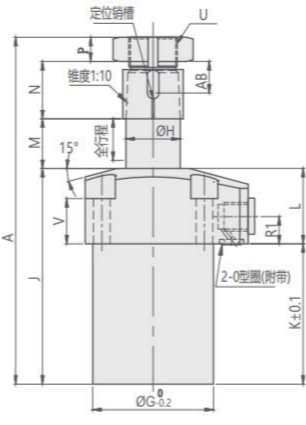

### DOUBLE SIDE SWING CLAMP

注:下图为转角90°松开状态

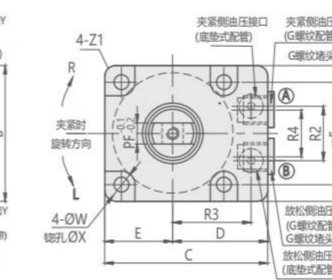
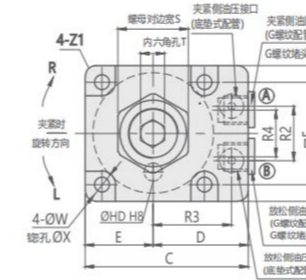
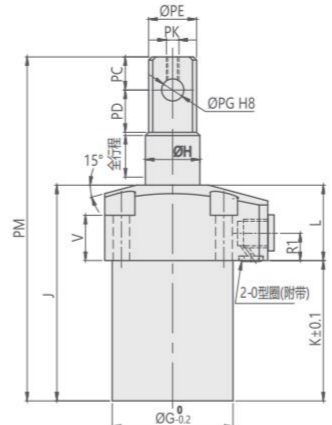

- Ⓐ 夹持油孔 Clamping port
- Ⓑ 放松油孔 Unclamping port

Unit:mm

MODEL ITEM	CHA-036P	CHA-040P	CHA-048P	CHA-055P	CHA-065P	CHA-075P	CHA-105P
A	117	131	148.5	158.5	178.5	201.5	244
B	38	45	50	57	70	86	108
C	48	55	60	66	82	96	120
PF	8	8	10	12	16	18	22
E	19	22.5	25	28.5	35	43	54
F	30.5	35	40	46	56	68	88
G	35	39	47	53	63	78	100
H	14	18	22.4	25	30	35.5	45
J	77	83	92	99	113	124.5	148.5
K	48.5	54	61	66	77	84	97
L	28.5	29	31	33	36	40.5	51.5
M	17.5	20	22.5	25.5	28.5	30	37.5
N(夹臂厚度)	16	20	25	25	27	35	45
P(螺母厚度)	6.5	8	9	9	10	12	13
R1	12.5	12.5	12.5	12.5	14	14	21
R2	18	22	24	28	36	45	50
R3	22.5	25	28	30.5	36	42	57
R4	16.2	20	22	26	30	38	50
S(螺母对边宽)	19	22	27	30	36	46	55
T(内六角孔)	5	6	6	8	8	10	14
U(推荐紧固扭矩)	M12x 1.5(12N·m)	M14x 1.5(26 N·m)	M18x 1.5(51 N·m)	M20x 1.5(60 N·m)	M24x 1.5(86 N·m)	M30x 1.5(120 N·m)	M39x 1.5(180 N·m)
V	20	19.5	20	20	19.5	20	26
W	4.3	5.5	5.5	6.8	9	11	14
X	8	9.5	9.5	11	14	17.5	20
Y	G1/8	G1/8	G1/8	G1/8	G1/4	G1/4	G3/8
Z1	R3	R3	R3	R5	R6	R7	R10
PE	12	16	20.4	23	28	33.5	43
PC	8	8	10	12	14	19	24
PD	9	9	11	13	15	20	25
AB	9	10.5	10.5	10.5	12.5	12.5	14.5
0型圈O-Ring	P7	P7	P7	P7	P8	P8	P10
PK	M3	M3	M4	M5	M6	M6	M8
PG	6 <sup>+0.018</sup> <sub>0</sub>	6 <sup>+0.018</sup> <sub>0</sub>	8 <sup>+0.022</sup> <sub>0</sub>	10 <sup>+0.022</sup> <sub>0</sub>	12 <sup>+0.027</sup> <sub>0</sub>	16 <sup>+0.027</sup> <sub>0</sub>	20 <sup>+0.033</sup> <sub>0</sub>
PM	113	121.5	137	151	172	195	236.5
HD	3+0.0140	4+0.0180	4+0.0180	5+0.0180	6+0.0180	6+0.0180	6+0.0180
定位销	Φ3(h8)×8	Φ4(h8)×10	Φ4(h8)×10	Φ5(h8)×10	Φ6(h8)×12	Φ6(h8)×12	Φ6(h8)×14

### 订购标示法 ORDERING INDICATION

#### 示例: CHA-040PSL-90

CHA-P	系列 Series	CHA-P
040	036/040/048/055/065/075/105	
S	压臂型式 Clamping arm type	S: 单边压臂 D: 双边压臂
L	转角方向 Swing direction	L: 左 R: 右 L: Left R: Right
90	转角角度 Swing angle	标准角度 Standard angle 90° (±2°) 可订做角度 Order angle 30° (±2°), 45° (±2°), 60° (±2°)

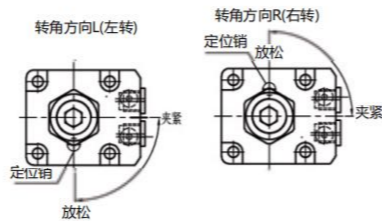

### 规格参数表 SPECIFICATIONS

型号 MODEL	理论夹持力 (70 kgf/cm <sup>2</sup> ) CLAMPING FORCE AT 70 kgf/cm <sup>2</sup> (kgf)	转角行程 SWING STROKE (mm)	夹紧行程 CLAMPING STROKE (mm)	总行程 TOTAL STROKE(mm)	推出容积 UNCLAMP(cm <sup>3</sup> ) CYLINDER CAPACITY UNCLAMP(cm <sup>3</sup> )	拉入容积 CLAMP(cm <sup>3</sup> ) CYLINDER CAPACITY CLAMP(cm <sup>3</sup> )	推出受压面积 UNCLAMP(cm <sup>2</sup> ) EFFPISTON AREA UNCLAMP(cm <sup>2</sup> )	拉入受压面积 CLAMP(cm <sup>2</sup> ) EFFPISTON AREA CLAMP(cm <sup>2</sup> )	使用温度范围 RANGE OF TEMPERATURE(°C)	使用流体 USABLE FLUID
CHA-036P	238	8	8	16	7.9	5.4	4.9	3.4	0~+70°C	相当于ISO黏度等级的ISO-VG-32一般液压油 Recommended: ISO-VG-32 hydraulic oil equivalent to ISO viscosity grade
CHA-040P	284.2	10	8	18	11.9	7.4	6.6	4.06	0~+70°C	
CHA-048P	434	12.5	8	20.5	20.9	12.7	10.2	6.2	0~+70°C	
CHA-055P	721	13.5	10	23.5	35.7	24.2	15.2	10.3	0~+70°C	
CHA-065P	880	16.5	10	26.5	52	33.3	19.63	12.57	0~+70°C	
CHA-075P	1631	18.5	10	28.5	94.6	66.4	33.17	23.3	0~+70°C	
CHA-105P	2583	23	13	36	190.1	132.9	52.78	36.9	0~+70°C	

# CBTU

## 方块形油压转角缸

## CBTU HYDRAULIC SWING CLAMP



### 产品特性

此系列产品配件采用优化设计,使体积更加紧凑,提高了产品强度。产品采用了专用防尘设计,提高了防尘和密封性实现了高密封性。产品结构具有高抗扭性,实现了高耐久性。

最大操作压力: 70 kgf/cm<sup>2</sup>  
 最小操作压力: 15 kgf/cm<sup>2</sup>  
 作动方式: 复动式

### FEATURES

The accessories of the CBTU series are optimally designed to create a more compact-sized product with enhanced strength. With its special dust-proof design, this product has improved its sealing performance and protects against any particles or debris while in use. The product's structure design has a high torsion resistance that achieves maximum durability.

Max. operating pressure: 70 kgf/cm<sup>2</sup>  
 Min. operating pressure: 15 kgf/cm<sup>2</sup>  
 Double acting

### 剖面图 Sectional view

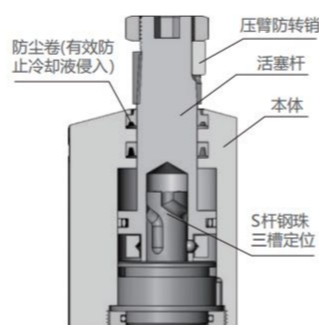

### 注意事项

夹紧及放松作动速度需适当放缓。  
 压臂安装拆卸方式,请参见第4页。  
 可接受订制,欢迎与本公司洽询。

### NOTE

The action and the speed of clamping / unclamping needs to be slowed down appropriately.  
 Please refer to Page 4 for installation instructions or removal methods of the clamping arm.  
 Customization is available upon request, please contact us for more info.

### 订购标示法 ORDERING INDICATION

#### 示例: CBTU-02L-90

CBTU	系列 Series	CBTU
02	02/04/06/10/16/25	
L	转角方向 Swing direction	L: 左 R: 右 L: Left R: Right
90	转角角度Swing angle	标准角度 Standard angle 90°(±2°) 可订做角度 Order angle 0°, 30°(±2°), 45°(±2°), 60°(±2°)

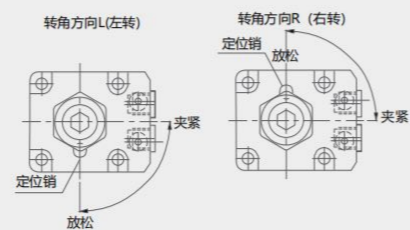

备注: 选配调速阀为CZL系列

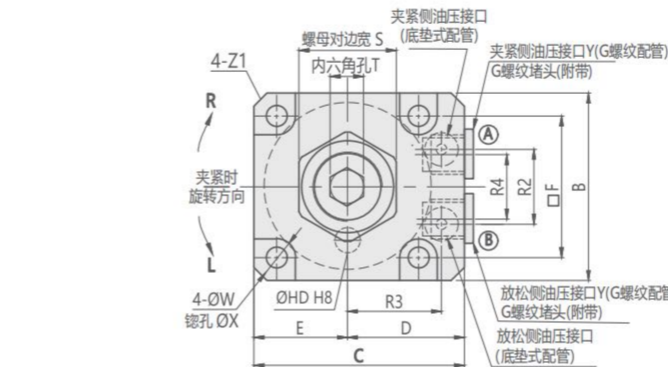
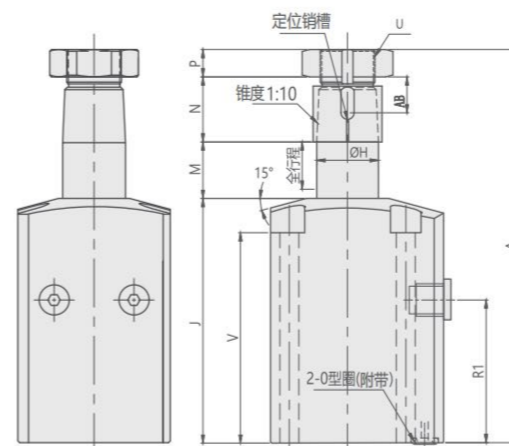

- Ⓐ 夹持油孔 Clamping port
- Ⓑ 放松油孔 Unclamping port

Unit:mm

MODEL ITEM	CBTU-02	CBTU-04	CBTU-06	CBTU-10	CBTU-16	CBTU-25
A	131	148.5	158.5	178.5	201.5	244
B	45	50	57	70	86	108
C	55	60	66	82	96	120
D	32.5	35	37.5	47	53	66
E	22.5	25	28.5	35	43	54
F	35	40	46	56	68	88
H	18	22.4	25	30	35.5	45
J	81.5	90.5	97.5	111.5	123	147
M	21.5	24	27	30	31.5	39
N(夹臂厚度)	20	25	25	27	35	45
P(螺母厚度)	8	9	9	10	12	13
R1	52.5	57	60	70	76	92
R2	22	24	28	36	45	50
R3	25	28	30.5	36	42	57
R4	20	22	26	30	38	50
S(螺母对边宽)	22	27	30	36	46	55
T(内六角孔)	6	6	8	8	10	14
U(推荐紧固扭矩)	M14x 1.5(26N·m)	M18x 1.5(51N·m)	M20x 1.5(60N·m)	M24x 1.5(86N·m)	M30x 1.5(120N·m)	M39x 1.5(180N·m)
V	71	80	85	95	102.5	121.5
W	5.5	5.5	6.8	9	11	14
X	9.5	9.5	11	14	17.5	20
Y	G1/8	G1/8	G1/8	G1/4	G1/4	G3/8
O型圈O-Ring	P7	P7	P7	P8	P8	P10
AB	10.5	10.5	10.5	12.5	12.5	14.5
Z1	C3	C3	C3	C4	C6	C6.5
HD	4 <sup>+0.018</sup> <sub>0</sub>	4 <sup>+0.018</sup> <sub>0</sub>	5 <sup>+0.018</sup> <sub>0</sub>	6 <sup>+0.018</sup> <sub>0</sub>	6 <sup>+0.018</sup> <sub>0</sub>	6 <sup>+0.018</sup> <sub>0</sub>
定位销	Φ4(h8)×10	Φ4(h8)×10	Φ5(h8)×10	Φ6(h8)×12	Φ6(h8)×12	Φ6(h8)×14

### 规格参数表 SPECIFICATIONS

型号	理论夹持力 (70 kgf/cm <sup>2</sup> )	转角行程	夹紧行程	总行程	推出容积	拉入容积	推出受压面积	拉入受压面积	使用温度范围	使用流体
MODEL	CLAMPING FORCE AT 70 kgf/cm <sup>2</sup> (kgf)	SWING STROKE (mm)	CLAMPING STROKE (mm)	TOTAL STROKE(mm)	CYLINDER CAPACITY UNCLAMP(cm <sup>3</sup> )	CYLINDER CAPACITY CLAMP(cm <sup>3</sup> )	EFFPISTON AREA UNCLAMP(cm <sup>2</sup> )	EFFPISTON AREA CLAMP(cm <sup>2</sup> )	RANGE OF TEMPERATURE(°C)	USABLE FLUID
CBTU-02	284.2	10	8	18	11.9	7.4	6.6	4.06	0~+70°C	相当于ISO黏度等级的ISO-VG-32一般液压油 Recommended: ISO-VG-32 hydraulic oil equivalent to ISO viscosity grade
CBTU-04	434	12.5	8	20.5	20.9	12.7	10.2	6.2	0~+70°C	
CBTU-06	721	13.5	10	23.5	35.7	24.2	15.2	10.3	0~+70°C	
CBTU-10	880	16.5	10	26.5	52	33.3	19.63	12.57	0~+70°C	
CBTU-16	1631	18.5	10	28.5	94.6	66.4	33.17	23.3	0~+70°C	
CBTU-25	2583	23	13	36	190.1	132.9	52.78	36.9	0~+70°C	

# CLAMPING ARM ACCESSORIES

## 压臂 配件尺寸

### CHA 系列

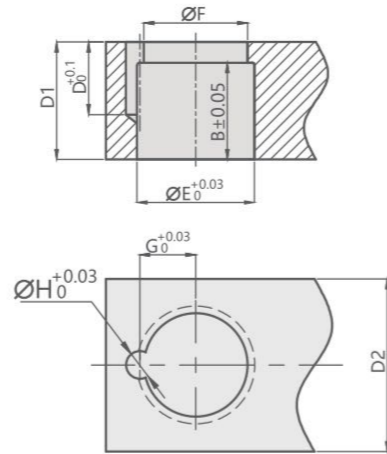

CHA油压转角缸压臂尺寸 CHA HYDRAULIC SWING CLAMP CYLINDER ARM ACCESSORIES

MODEL ITEM	CHA-036	CHA-040	CHA-048	CHA-055	CHA-065	CHA-075	CHA-090	CHA-105
<b>B</b>	14	16	19	22	25	31	38	44
<b>D</b>	10.5	10.5	12.5	14.5	16.5	17.5	17.5	20.5
<b>D1</b>	17	19	23	26	29	35	43	50
<b>D2</b>	25	32	40	45	50	58	75	90
<b>E</b>	17	20	25	28	34	40	49	60
<b>F</b>	15	17	21	23	29	33	42	51
<b>G</b>	8	9	11.5	13	15.5	18	22.5	28
<b>H</b>	4	4	5	6	6	8	8	10

### CHA-P/CBTU 系列

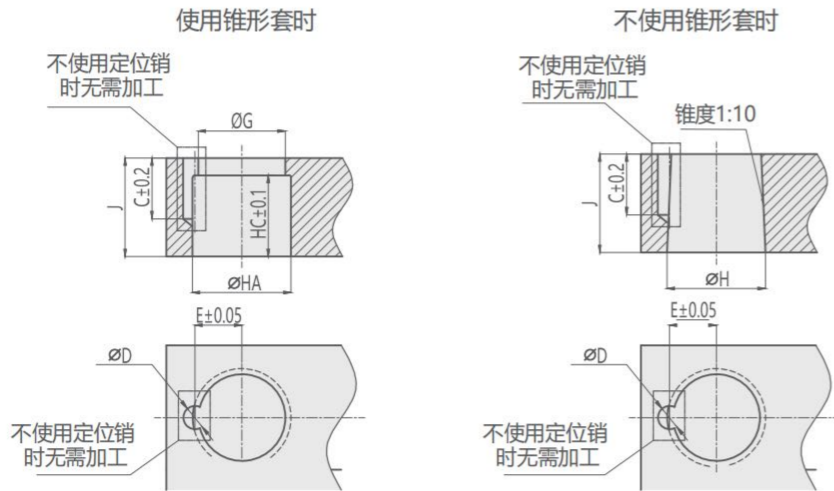

CHA-P/CBTU油压转角缸压臂尺寸 CBTU HYDRAULIC SWING CLAMP CYLINDER ARM ACCESSORIES

MODEL ITEM	CHA-036P	CHA-040P CBTU-02	CHA-048P CBTU-04	CHA-055P CBTU-06	CHA-065P CBTU-10	CHA-075P CBTU-16	CHA-105P CBTU-25
<b>HA</b>	16 <sup>+0.027</sup> <sub>0</sub>	20 <sup>+0.033</sup> <sub>0</sub>	25 <sup>+0.033</sup> <sub>0</sub>	28 <sup>+0.033</sup> <sub>0</sub>	34 <sup>+0.039</sup> <sub>0</sub>	40 <sup>+0.039</sup> <sub>0</sub>	49 <sup>+0.039</sup> <sub>0</sub>
<b>HC</b>	13	16	21	20	22	29	38
<b>C</b>	9	10.5	10.5	10.5	12.5	12.5	14.5
<b>D</b>	3 <sup>+0.014</sup> <sub>0</sub>	4 <sup>+0.018</sup> <sub>0</sub>	4 <sup>+0.018</sup> <sub>0</sub>	5 <sup>+0.018</sup> <sub>0</sub>	6 <sup>+0.018</sup> <sub>0</sub>	6 <sup>+0.018</sup> <sub>0</sub>	6 <sup>+0.018</sup> <sub>0</sub>
<b>E</b>	7.55	9.1	11.1	12.6	15.1	18.1	22.6
<b>G</b>	13	17	21	24	28.5	34	42
<b>H</b>	14 <sup>-0.016</sup> <sub>-0.034</sub>	18 <sup>-0.016</sup> <sub>-0.034</sub>	22.4 <sup>-0.020</sup> <sub>-0.041</sub>	25 <sup>-0.020</sup> <sub>-0.041</sub>	30 <sup>-0.020</sup> <sub>-0.041</sub>	35.5 <sup>-0.025</sup> <sub>-0.050</sub>	45 <sup>-0.025</sup> <sub>-0.050</sub>
<b>J</b>	16	20	25	25	27	35	45

Model: CHA-036

供给油压 MPa	夹紧器 输出KN	夹紧力 KN 压板长度L(mm)							最大压板长度(L) (mm)
		L=30	L=40	L=50	L=60	L=80	L=100	L=120	
7	248	2.2	2.1	2.0	1.9	1.8	不可使用		96
6.5	230	2.0	1.9	1.9	1.8	1.7	1.5		110
6	213	1.9	1.8	1.7	1.7	1.5	1.4	1.3	129
5.5	195	1.7	1.6	1.6	1.5	1.4	1.3	1.2	150
5	177	1.6	1.5	1.4	1.4	1.3	1.2	1.1	150
4.5	159	1.4	1.4	1.3	1.3	1.2	1.1	1.0	150
4	142	1.3	1.2	1.2	1.1	1.0	1.0	0.9	150
3.5	124	1.1	1.1	1.0	1.0	0.9	0.8	0.8	150
3	106	1.0	0.9	0.9	0.8	0.8	0.7	0.6	150
2.5	089	0.8	0.8	0.7	0.7	0.7	0.6	0.5	150
2	071	0.7	0.6	0.6	0.6	0.5	0.5	0.5	150
1.5	053	0.5	0.5	0.5	0.4	0.4	0.4	0.3	150
最高使用压力(MPa)		7.0	7.0	7.0	7.0	7.0	6.9	6.3	5.6

Model: CHA-040

供给油压 MPa	夹紧器 输出KN	夹紧力 KN 压板长度L(mm)							最大压板长度(L) (mm)	
		L=40	L=50	L=60	L=70	L=80	L=100	L=120		L=150
7	350	3.0	2.9	2.8	2.7	2.6	2.4	2.2	不可使用	124
6.5	325	2.7	2.7	2.6	2.5	2.4	2.2	2.1	使用	144
6	300	2.5	2.5	2.4	2.3	2.2	2.1	1.9	1.7	171
5.5	275	2.3	2.3	2.2	2.1	2.0	1.9	1.8	1.6	210
5	250	2.1	2.1	2.0	1.9	1.9	1.7	1.6	1.5	210
4.5	225	1.9	1.9	1.8	1.7	1.7	1.6	1.5	1.3	210
4	200	1.7	1.7	1.6	1.5	1.5	1.4	1.3	1.2	210
3.5	175	1.5	1.4	1.4	1.4	1.3	1.2	1.1	1.0	210
3	150	1.3	1.2	1.2	1.2	1.1	1.1	1.0	0.9	210
2.5	125	1.1	1.0	1.0	1.0	0.9	0.9	0.8	0.8	210
2	100	0.9	0.8	0.8	0.8	0.8	0.7	0.7	0.6	210
1.5	075	0.7	0.6	0.6	0.6	0.6	0.5	0.5	0.5	210
最高使用压力(MPa)		7.0	7.0	7.0	7.0	7.0	7.0	7.0	6.4	

Model: CHA-048

供给油压 MPa	夹紧器 输出KN	夹紧力 KN 压板长度L(mm)							最大压板长度(L) (mm)	
		L=50	L=60	L=80	L=100	L=120	L=140	L=160		L=200
7	487	4.3	4.2	4.0	3.9	3.7	3.6	不可使用		141
6.5	452	4.0	3.9	3.7	3.6	3.4	3.3			157
6	417	3.7	3.6	3.5	3.3	3.2	3.1	2.9		178
5.5	382	3.4	3.3	3.2	3.0	2.9	2.8	2.7	2.5	190
5	348	3.1	3.0	2.9	2.8	2.7	2.6	2.5	2.3	215
4.5	313	2.8	2.7	2.6	2.5	2.4	2.3	2.2	2.0	215
4	278	2.5	2.4	2.3	2.2	2.1	2.1	2.0	1.8	215
3.5	243	2.2	2.1	2.0	2.0	1.9	1.8	1.7	1.6	215
3	209	1.9	1.8	1.7	1.7	1.6	1.6	1.5	1.4	215
2.5	174	1.6	1.5	1.5	1.4	1.4	1.3	1.2	1.2	215
2	139	1.3	1.2	1.2	1.1	1.1	1.0	1.0	0.9	215
1.5	104	1.0	0.9	0.9	0.8	0.8	0.8	0.8	0.7	215
最高使用压力(MPa)		7.0	7.0	7.0	7.0	7.0	7.0	6.6	5.7	

Model: CHA-055

供给油压 MPa	夹紧器 输出KN	夹紧力 KN 压板长度L(mm)							最大压板长度(L) (mm)	
		L=50	L=60	L=80	L=100	L=120	L=140	L=160		L=200
7	721	6.3	6.2	5.9	5.6	5.4	5.2	不可使用		142
6.5	669	5.8	5.7	5.5	5.2	5.0	4.8			159
6	618	5.4	5.3	5.1	4.8	4.6	4.4	4.2		180
5.5	566	5.0	4.8	4.6	4.4	4.2	4.1	3.9	3.6	200
5	515	4.5	4.4	4.2	4.0	3.9	3.7	3.5	3.2	225
4.5	463	4.1	4.0	3.8	3.6	3.5	3.3	3.2	2.9	225
4	412	3.6	3.5	3.4	3.2	3.1	3.0	2.8	2.6	225
3.5	360	3.2	3.1	3.0	2.8	2.7	2.6	2.5	2.3	225
3	309	2.7	2.7	2.6	2.4	2.3	2.2	2.1	2.0	225
2.5	257	2.3	2.2	2.1	2.0	2.0	1.9	1.8	1.6	225
2	206	1.8	1.8	1.7	1.6	1.6	1.5	1.4	1.3	225
1.5	154	1.4	1.4	1.3	1.2	1.2	1.1	1.1	1.0	225
最高使用压力(MPa)		7.0	7.0	7.0	7.0	7.0	7.0	6.4	5.6	

Model: CHA-065

供给油压 MPa	夹紧器 输出KN	夹紧力 KN 压板长度L(mm)							最大压板长度(L) (mm)	
		L=50	L=60	L=80	L=100	L=120	L=140	L=160		L=200
7	935	8.1	7.9	7.6	7.3	不可使用			115	
6.5	868	7.5	7.3	7.0	6.7	6.5			127	
6	802	6.9	6.8	6.5	6.2	6.0	5.7			142
5.5	735	6.4	6.2	6.0	5.7	5.5	5.3	5.0		161
5	668	5.8	5.7	5.4	5.2	5.0	4.8	4.6		187
4.5	601	5.2	5.1	4.9	4.7	4.5	4.3	4.1	3.8	221
4	534	4.6	4.5	4.4	4.2	4.0	3.8	3.7	3.4	240
3.5	468	4.1	4.0	3.8	3.7	3.5	3.4	3.2	3.0	240
3	401	3.5	3.4	3.4	3.1	3.0	2.9	2.8	2.5	240
2.5	334	2.9	2.9	2.7	2.6	2.5	2.4	2.3	2.1	240
2	267	2.3	2.3	2.2	2.1	2.0	1.9	1.9	1.7	240
1.5	200	1.8	1.7	1.7	1.6	1.5	1.5	1.4	1.3	240
最高使用压力(MPa)		7.0	7.0	7.0	7.0	6.8	6.1	5.6	4.8	

Model: CHA-075

供给油压 MPa	夹紧器 输出KN	夹紧力 KN 压板长度L(mm)							最大压板长度(L) (mm)		
		L=50	L=60	L=80	L=100	L=120	L=140	L=160		L=200	
7	1421	12.4	12.2	11.7	11.3	10.9	10.5	不可使用		147	
6.5	1319	11.5	11.3	10.7	10.5	10.2	9.8	9.5			163
6	1218	10.6	10.4	10.1	9.7	9.4	9.0	8.7			184
5.5	1116	9.7	9.6	9.2	8.9	8.6	8.3	8.0	7.5	209	
5	1015	8.9	8.7	8.4	8.1	7.8	7.5	7.3	6.8	230	
4.5	913	8.0	7.8	7.6	7.3	7.0	6.8	6.6	6.1	255	
4	812	7.1	7.0	6.7	6.5	6.3	6.0	5.8	5.4	255	
3.5	710	6.2	6.1	5.9	5.7	5.5	5.3	5.1	4.8	255	
3	609	5.3	5.2	5.1	4.9	4.7	4.5	4.4	4.1	255	
2.5	507	4.5	4.4	4.2	4.1	3.9	3.8	3.7	3.4	255	
2	406	3.6	3.5	3.4	3.3	3.2	3.0	2.9	2.7	255	
1.5	304	2.7	2.6	2.5	2.5	2.4	2.3	2.2	2.1	255	
最高使用压力(MPa)		7.0	7.0	7.0	7.0	7.0	7.0	6.9	5.9		

Model: CHA-090

供给油压 MPa	夹紧器 输出KN	夹紧力 KN 压板长度L(mm)							最大压板长度(L) (mm)
		L=60	L=75	L=100	L=120	L=140	L=170	L=200	
7	2062	17.5	17.0	16.2	15.6	14.9	14.1		

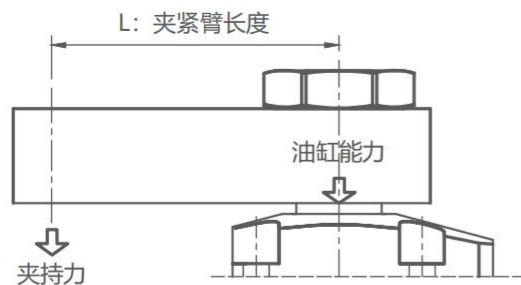

Model: CHA-036P

油压 MPa	油缸能力 KN	夹紧力 KN								最大臂长 Max.L (mm)	
		夹紧臂长度 L mm									
		30	35	40	50	60	80	100	120		
7	2.4	2.0	2.0	不可使用							39
6.5	2.2	1.9	1.9	1.8						43	
6	2.0	1.7	1.7	1.7					48		
5.5	1.9	1.6	1.6	1.5	1.5				53		
5	1.7	1.5	1.4	1.4	1.3	1.3			61		
4.5	1.5	1.3	1.3	1.3	1.2	1.2			70		
4	1.3	1.2	1.1	1.1	1.1	1.0	1.0			83	
3.5	1.2	1.0	1.0	1.0	0.9	0.9	0.8	0.8		102	
3	1.0	0.9	0.9	0.8	0.8	0.8	0.7	0.7	0.6	131	
2.5	0.8	0.7	0.7	0.7	0.7	0.6	0.6	0.6	0.5	↑	
2	0.7	0.6	0.6	0.6	0.5	0.5	0.5	0.4	0.4	↑	
1.5	0.5	0.4	0.4	0.4	0.4	0.4	0.4	0.3	0.3	131	

Model: CHA-040P/CBTU-02

油压 MPa	油缸能力 KN	夹紧力 KN								最大臂长 Max.L (mm)	
		夹紧臂长度 L mm									
		35	40	50	60	80	100	120	140		
7	2.8	2.4	2.4	2.3	2.2	2.1	不可使用			80	
6.5	2.6	2.3	2.2	2.1	2.1	1.9				89	
6	2.4	2.1	2.1	2.0	1.9	1.8	1.7			101	
5.5	2.2	1.9	1.9	1.8	1.7	1.6	1.5			115	
5	2.0	1.7	1.7	1.6	1.6	1.5	1.4	1.3			135
4.5	1.8	1.6	1.5	1.5	1.4	1.3	1.2	1.2	1.1	162	
4	1.6	1.4	1.4	1.3	1.3	1.2	1.1	1.0	1.0	202	
3.5	1.4	1.2	1.2	1.2	1.1	1.0	1.0	0.9	0.9	↑	
3	1.2	1.0	1.0	1.0	1.0	0.9	0.8	0.8	0.7	↑	
2.5	1.0	0.9	0.9	0.8	0.8	0.7	0.7	0.6	0.6	↑	
2	0.8	0.7	0.7	0.7	0.6	0.6	0.6	0.5	0.5	↑	
1.5	0.6	0.5	0.5	0.5	0.5	0.4	0.4	0.4	0.4	202	

Model: CHA-048P/CBTU-04

油压 MPa	油缸能力 KN	夹紧力 KN								最大臂长 Max.L (mm)	
		夹紧臂长度 L mm									
		40	50	60	80	100	120	140	160		
7	4.4	3.8	3.6	3.5	3.3	3.1	不可使用			105	
6.5	4.1	3.5	3.4	3.3	3.0	2.9				117	
6	3.8	3.2	3.1	3.0	2.8	2.7	2.5			133	
5.5	3.4	2.9	2.8	2.8	2.6	2.4	2.3	2.2			153
5	3.1	2.7	2.6	2.5	2.3	2.2	2.1	2.0	1.9	181	
4.5	2.8	2.4	2.3	2.3	2.1	2.0	1.9	1.8	1.7	220	
4	2.5	2.1	2.1	2.0	1.9	1.8	1.7	1.6	1.5	↑	
3.5	2.2	1.9	1.8	1.8	1.6	1.5	1.5	1.4	1.3	↑	
3	1.9	1.6	1.6	1.5	1.4	1.3	1.3	1.2	1.1	↑	
2.5	1.6	1.3	1.3	1.3	1.2	1.1	1.0	1.0	0.9	↑	
2	1.3	1.1	1.0	1.0	0.9	0.9	0.8	0.8	0.8	↑	
1.5	0.9	0.8	0.8	0.8	0.7	0.7	0.6	0.6	0.6	220	

Model: CHA-055P/CBTU-06

油压 MPa	油缸能力 KN	夹紧力 KN								最大臂长 Max.L (mm)	
		夹紧臂长度 L mm									
		50	60	80	100	120	140	160	180		
7	6.3	5.3	5.1	4.8	不可使用					96	
6.5	5.8	4.9	4.7	4.5	4.2					107	
6	5.4	4.5	4.4	4.1	3.9	3.7				120	
5.5	4.9	4.1	4.0	3.8	3.6	3.4				137	
5	4.5	3.8	3.6	3.4	3.2	3.1	2.9	2.8			160
4.5	4.0	3.4	3.3	3.1	2.9	2.8	2.6	2.5	2.4	191	
4	3.6	3.0	2.9	2.7	2.6	2.5	2.3	2.2	2.1	238	
3.5	3.1	2.6	2.5	2.4	2.3	2.2	2.0	1.9	1.9	↑	
3	2.7	2.3	2.2	2.1	1.9	1.8	1.8	1.7	1.6	↑	
2.5	2.2	1.9	1.8	1.7	1.6	1.5	1.5	1.4	1.3	↑	
2	1.8	1.5	1.5	1.4	1.3	1.2	1.2	1.1	1.1	↑	
1.5	1.3	1.1	1.1	1.0	1.0	0.9	0.9	0.8	0.8	238	

Model: CHA-065P/CBTU-10

油压 MPa	油缸能力 KN	夹紧力 KN								最大臂长 Max.L (mm)	
		夹紧臂长度 L mm									
		60	80	100	120	140	160	180	200		
7	9.9	8.3	7.9	7.5	不可使用					102	
6.5	9.2	7.7	7.3	7.0						113	
6	8.5	7.1	6.8	6.4	6.1				127		
5.5	7.8	6.5	6.2	5.9	5.6	5.4			144		
5	7.1	5.9	5.6	5.4	5.1	4.9	4.7			167	
4.5	6.4	5.3	5.1	4.8	4.6	4.4	4.2	4.0			199
4	5.7	4.7	4.5	4.3	4.1	3.9	3.7	3.6	3.4	245	
3.5	5.0	4.2	3.9	3.7	3.6	3.4	3.3	3.1	3.0	↑	
3	4.2	3.6	3.4	3.2	3.1	2.9	2.8	2.7	2.6	↑	
2.5	3.5	3.0	2.8	2.7	2.6	2.4	2.3	2.2	2.2	↑	
2	2.8	2.4	2.3	2.1	2.0	2.0	1.9	1.8	1.7	↑	
1.5	2.1	1.8	1.7	1.6	1.5	1.5	1.4	1.3	1.3	245	

Model: CHA-075P/CBTU-16

油压 MPa	油缸能力 KN	夹紧力 KN								最大臂长 Max.L (mm)	
		夹紧臂长度 L mm									
		70	80	100	120	140	160	180	200		
7	16.3	13.5	13.2	不可使用					99		
6.5	15.2	12.5	12.2	11.7					110		
6	14.0	11.6	11.3	10.8	10.3				123		
5.5	12.8	10.6	10.4	9.9	9.4				139		
5	11.7	9.6	9.4	9.0	8.6	8.2	7.9			161	
4.5	10.5	8.7	8.5	8.1	7.7	7.4	7.1	6.8			190
4	9.3	7.7	7.5	7.2	6.9	6.6	6.3	6.1	5.8	231	
3.5	8.2	6.7	6.6	6.3	6.0	5.8	5.5	5.3	5.1	↑	
3	7.0	5.8	5.6	5.4	5.1	4.9	4.7	4.5	4.4	↑	
2.5	5.8	4.8	4.7	4.5	4.3	4.1	3.9	3.8	3.6	↑	
2	4.7	3.9	3.8	3.6	3.4	3.3	3.2	3.0	2.9	↑	
1.5	3.5	2.9	2.8	2.7	2.6	2.5	2.4	2.3	2.2	231	

Model: CHA-105P/CBTU-25

油压 MPa	油缸能力 KN	夹紧力 KN								最大臂长 Max.L (mm)	
		夹紧臂长度 L mm									
		90	100	120	140	160	180	200	240		
7	25.8	21.2	20.8	20.0	不可使用					129	
6.5	24.0	19.7	19.3	18.6	17.9					143	
6	22.1	18.2	17.8	17.1	16.5	15.9				161	
5.5	20.3	16.7	16.3	15.7	15.1	14.6	14.1			183	
5	18.5	15.1	14.8	14.3	13.8	13.3	12.8	12.4			212
4.5	16.6	13.6	13.4	12.9	12.4	12.0	11.6	11.2	10.5	251	
4	14.8	12.1	11.9	11.4	11.0	10.6	10.3	9.9	9.3	308	
3.5	12.9	10.6	10.4	10.0	9.6	9.3	9.0	8.7	8.2	↑	
3	11.1	9.1	8.9	8.6	8.3	8.0	7.7	7.5	7.0	↑	
2.5	9.2	7.6	7.4	7.1	6.9	6.6	6.4	6.2	5.8	↑	
2	7.4	6.1	5.9	5.7	5.5	5.3	5.1	5.0	4.7	↑	
1.5	5.5	4.5	4.5	4.3	4.1	4.0	3.9	3.7	3.5	308	

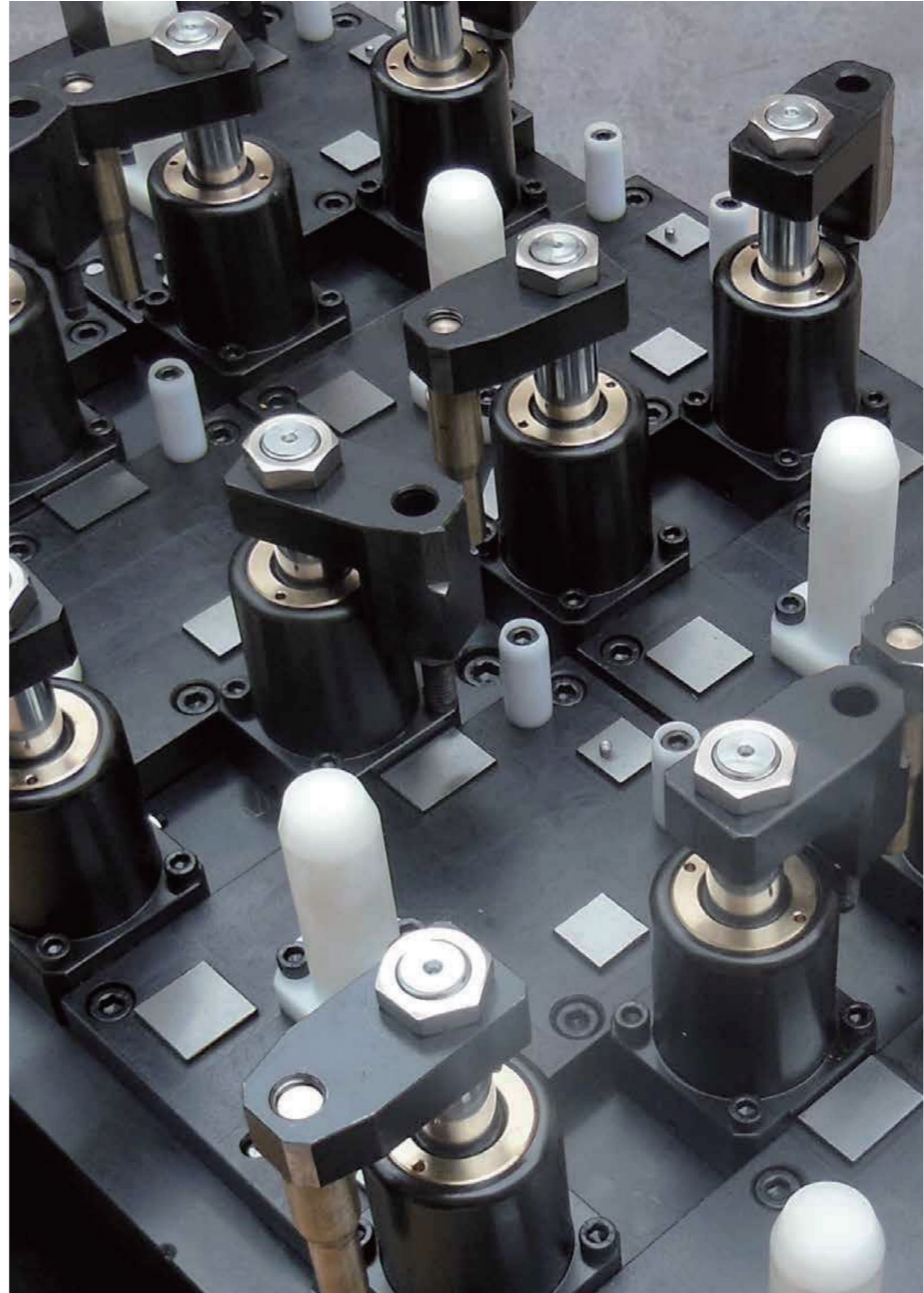

# CHS

## 油压转角缸

### CHS HYDRAULIC SWING CLAMP



#### 产品特性

本产品适用于量产零件之专用机及MC治具,为提高生产效率的好帮手。主要功能为油压缸动作时,活塞下压行程中压板会旋转到设计的角度,再沿著直线继续下压直到压板夹紧工件。

建议使用油压转角缸,请加装流量控制阀,避免速度过快,以及转角行程中,请勿夹持工件。缸体材质采用机械构造用碳素钢,内壁特殊加工处理,表面光滑,使用寿命长。

最大操作压力: 70 kgf/cm<sup>2</sup>  
 最小操作压力: 15 kgf/cm<sup>2</sup>  
 作动方式: 复动式

#### FEATURES

The CHS series is made with industrial grade carbon steel and processed with hardened surface treatment to increase durability and extend product lifespan. It is designed to increase production efficiency for machinery and MC fixtures used for mass production. During the actuation state, the piston rod will drive the clamping arm downward and rotate to the desired position and angle. When the swing clamp is in action, the piston rod will drive the clamping arm to press down and rotate to the desired position and angle, thereby clamping the workpiece. For operational instructions, do not clamp the workpiece during the rotation. Also, installation of a flow control valve is highly recommended to help avoid excessive speed.

Max. operating pressure: 70 kgf/cm<sup>2</sup>  
 Min. operating pressure: 15 kgf/cm<sup>2</sup>  
 Double acting

#### 剖面图 Sectional view

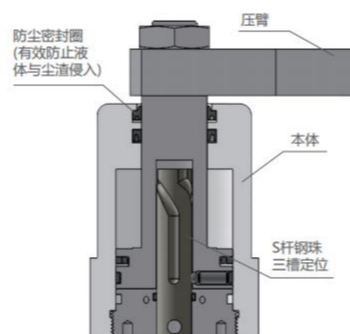

#### 注意事项

夹紧及放松作动速度需适当放缓。特殊压臂长度及重量不得超过标准压臂的1.5倍。压臂旋转示意图及安装拆卸方式,请参见第4页。

#### NOTE

The action and the speed of clamping / unclamping needs to be slowed down appropriately. The length and weight of the customized clamping arm shall not exceed 1.5 times of the standard clamping arm. Please refer to page 4 for the rotation diagram, installation instructions and removal methods of the clamping arm.

#### 订购标示法 ORDERING INDICATION

示例: CHS-MF25SR-90-E-M-S1D

CHS	系列 Series	CHS			
MF	类型 Type	空白: 配管式 MF: 油路板附调速 M: 油路板型 FA: 法兰型	Line type Manifold with flow control Manifold type Flange type	TB: 全牙型 FAM: 法兰型油路板 FAMT: 法兰型油路板附调速	Threaded body Flange with manifold Flange with flow control
25	油缸内径 Hydraulic cylinder inside diameter	Φ25, Φ32, Φ40, Φ50, Φ63			
S	压板型式 Clamping arm type	S: 单边压板 D: 双边压板	S: Single side arm D: Double side arm		
R	转角方向 Swing direction	R: 顺时针右转 R: Turn right	L: 逆时针左转 L: Turn left	N: 0°不旋转 N: 0° No swing	
90	转角角度 Swing angle	标准角度 Standard angle 90° (±2°)		订做角度 Order angle 0°, 45° (±2°), 60° (±2°)	
E	行程加长 Extended travel	行程加长型	Stroke extension (具体加长型见后面规格尺寸表)		
M	带磁石 Magnet	其中Φ25缸径和FA/TB/FAM/FAMT类型无磁感应型			
S1D	近接开关 Proximity Switch	S1: 1个	S2: 2个	电压AC 4~120V	D: 直流 A: 交流

#### 规格参数表 SPECIFICATIONS

型号	理论夹持力 (70 kgf/cm <sup>2</sup> )	转角行程	标准 垂直行程	加长 垂直行程	标准总行程	加长总行程	标准拉入 容积	加长行程 拉入容积	标准行程 推出容积	加长行程 推出容积	拉入受压 面积	推出受压 面积	使用温度 范围
MODEL	CLAMPING FORCE AT 70 kgf/cm <sup>2</sup> (kgf)	SWING STROKE (mm)	STANDARD CLAMPING STROKE (mm)	EXTENDED CLAMPING STROKE (mm)	STANDARD TOTAL STROKE (mm)	EXTENDED TOTAL STROKE (mm)	OIL STANDARD CAPACITY CLAMP (cm <sup>3</sup> )	OIL EXTENDED CAPACITY CLAMP (cm <sup>3</sup> )	OIL STANDARD CAPACITY UNCLAMP (cm <sup>3</sup> )	OIL EXTENDED CAPACITY UNCLAMP (cm <sup>3</sup> )	EFF.PISTON AREA CLAMP (cm <sup>2</sup> )	EFF.PISTON AREA UNCLAMP (cm <sup>2</sup> )	RANGE OF TEMPERATURE (°C)
CHS-25	166	CHS 11.5	13	-	24.5	-	5.81	-	12.03	-	2.37	4.91	-10~+70°C
CHS-32	343	CHS 14.5	15	30	29.5	44.5	14.45	21.81	23.72	37.38	4.9	8.04	-10~+70°C
CHS-40	603	CHS 14.5	15	30	29.5	44.5	25.43	38.36	37.05	55.89	8.62	12.56	-10~+70°C
CHS-50	943	CHS 16	17	34	33	50	44.45	67.35	64.78	98.15	13.47	19.63	-10~+70°C
CHS-63	1488	CHS 16	17	34	33	50	70.16	106.3	102.83	155.8	21.26	31.16	-10~+70°C
CHS-80 仅配管式 Only Line type	2639	CHS 15	15	-	30	-	113.1	-	150.72	-	37.7	50.27	-10~+70°C

使用流体: 相当于ISO黏度等级的ISO-VG-32一般液压油  
 Recommended: ISO-VG-32 hydraulic oil equivalent to ISO viscosity grade

配管式 LINE TYPE-S

Single side swing clamp

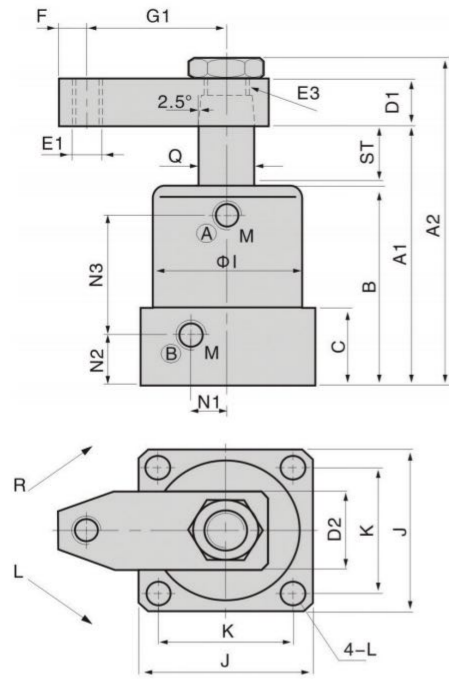

- Ⓐ 夹持油孔 Clamping port
- Ⓑ 放松油孔 Unclamping port

配管式 LINE TYPE-D

Double side swing clamp

注:下图为转角90°松开状态

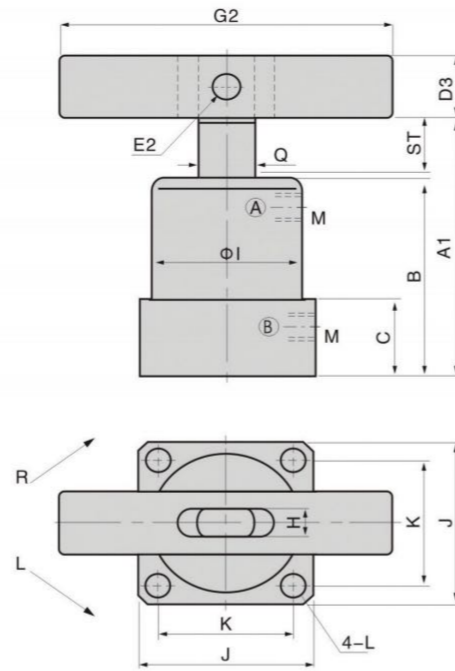

Unit:mm

MODEL ITEM	CHS-25	CHS-32	CHS-40	CHS-50	CHS-63	CHS-80
ST:Swing/Clamping	24.5:11.5/13	29.5:14.5/15	44.5:14.5/30	29.5:14.5/15	44.5:14.5/30	33:16/17 50:16/34
A1 Undamping	104	118	148	123	153	137 171 142 176
A2 Undamping	127	144	175	150	180	167 201 177 211
B	76	85	100	90	105	100 117 105 122
C	27	30	30	34	34	34
D1	16	18	18	20	23	28
D2	27	31	31	37	48	52
D3	□19	□22	□22	□25	□32	□34
E1	M10	M10	M10	M12	M16	M16
E2	φ8	φ8	φ10	φ12	φ15	φ16
E3	M14×1.5	M16×1.5	M18×1.5	M20×1.5	M24×2	M30×2
F	10	10	10	12	15	20
G1	50	55	60	65	75	85
G2	140	160	160	180	200	220
H	9	10	10	12	15	16
ϕI	φ46	φ50	φ54	φ66	φ80	φ100
J	52	56	63	72	88	110
K	40	44	48	57	70	87
L	φ6.8	φ6.8	φ9	φ9	φ11	φ13
M	PT1/8	PT1/8	PT1/8	PT1/4	PT1/4	PT1/4
N1	8	10	12	15	17	17
N2	17	19	19	21.5	22	25
N3	46	52	67	57	72	63.5 80.5 68 85 65
Q	φ18	φ20	φ22.4	φ28	φ35.5	φ40

油路板附调速 MF-S

Single side swing clamp

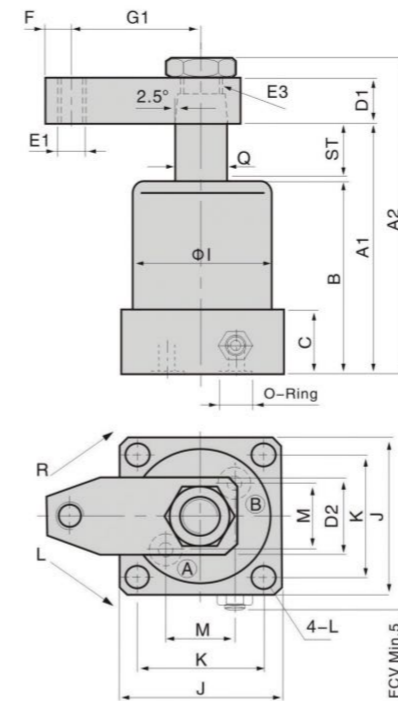

- Ⓐ 夹持油孔 Clamping port
- Ⓑ 放松油孔 Unclamping port

油路板附调速 MF-D

Double side swing clamp

注:下图为转角90°松开状态

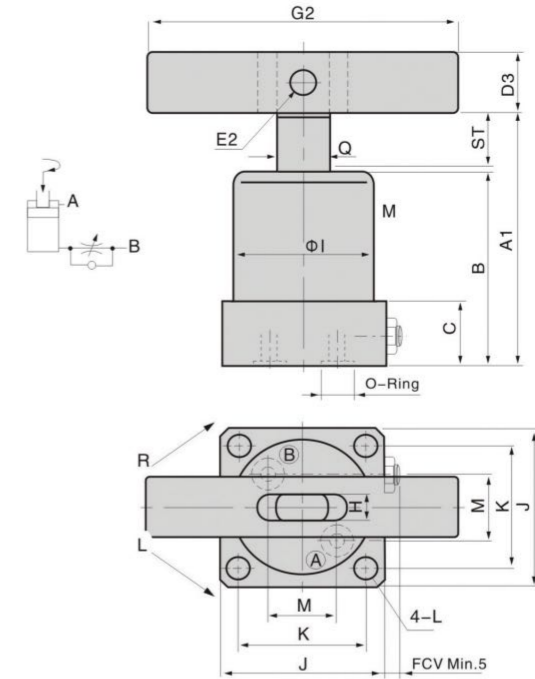

Unit:mm

MODEL ITEM	CHS-MF25	CHS-MF32	CHS-MF40	CHS-MF50	CHS-MF63
ST:Swing/Clamping	24.5:11.5/13	29.5:14.5/15	44.5:14.5/30	29.5:14.5/15	44.5:14.5/30
A1 Undamping	104	118	148	123	153
A2 Undamping	127	144	175	150	180
B	76	85	100	90	105
C	22	25	25	30	30
D1	16	18	18	20	23
D2	27	31	31	37	48
D3	□19	□22	□22	□25	□32
E1	M10	M10	M10	M12	M16
E2	φ8	φ8	φ10	φ12	φ15
E3	M14×1.5	M16×1.5	M18×1.5	M20×1.5	M24×2
F	10	10	10	12	15
G1	50	55	60	65	75
G2	140	160	160	180	200
H	9	10	10	12	15
ϕI	φ46	φ50	φ54	φ66	φ80
J	55	57	63	72	88
K	42	44	48	57	70
L	φ6.8	φ6.8	φ9	φ9	φ11
M	19	21	23	28	32
O-Ring	P7	P7	P9	P9	P9
Q	φ18	φ20	φ22.4	φ28	φ35.5

油路板型 M-S

Single side swing clamp

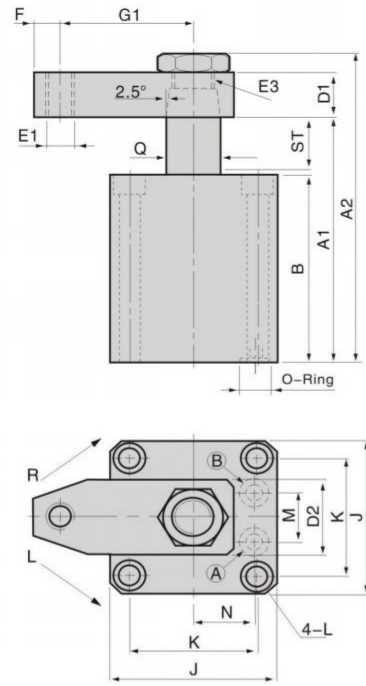

油路板型 M-D

Double side swing clamp

注:下图为转角90°松开状态

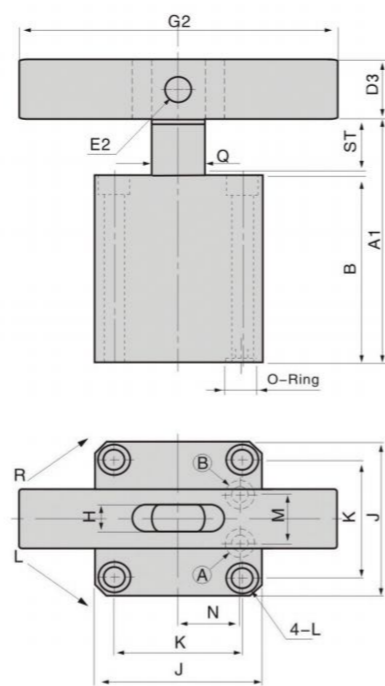

- Ⓐ 夹持油孔 Clamping port
- Ⓑ 放松油孔 Unclamping port

配管式LINE TYPE-SM

Single side swing clamp

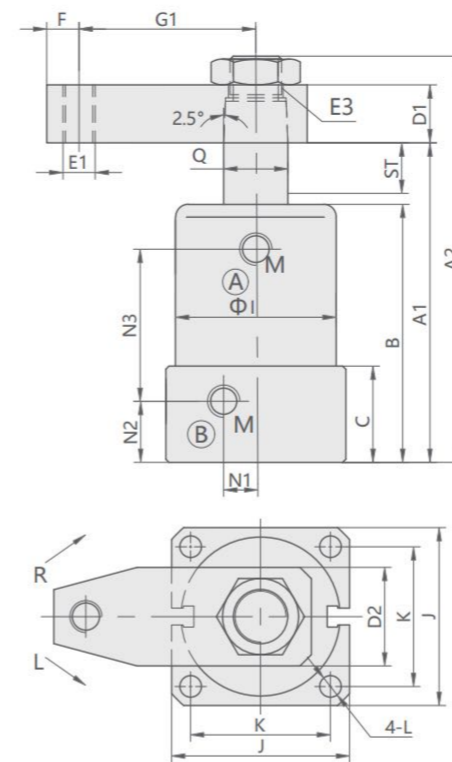

配管式LINE TYPE-DM

Double side swing clamp

注:下图为转角90°松开状态

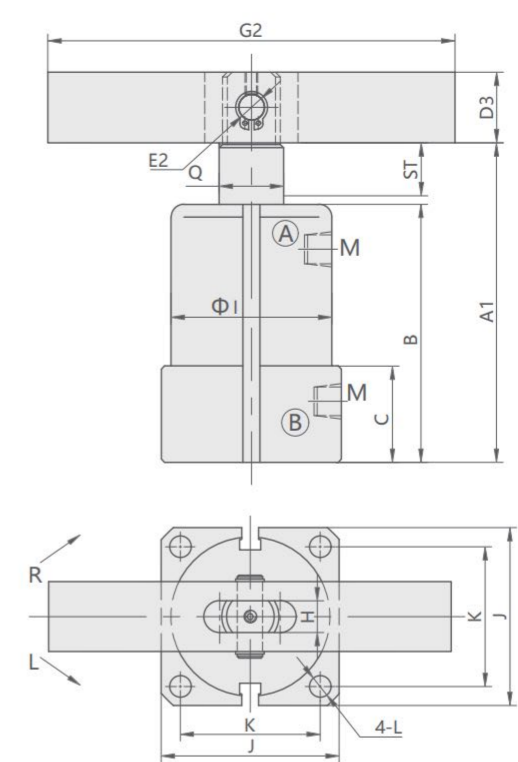

- Ⓐ 夹持油孔 Clamping port
- Ⓑ 放松油孔 Unclamping port

Unit:mm

MODEL ITEM	CHS-M25	CHS-M32	CHS-M40	CHS-M50	CHS-M63
ST:Swing/Clamping	24.5:11.5/13	29.5:14.5/15	29.5:14.5/15	33:16/17	33:16/17
A1 Unclamping	104	118	123	137	142
A2 Unclamping	127	144	150	167	177
B	76	85	90	100	105
D1	16	18	18	20	23
D2	27	31	31	37	48
D3	□19	□22	□22	□25	□32
E1	M10	M10	M10	M12	M16
E2	φ8	φ8	φ10	φ12	φ15
E3	M14×1.5	M16×1.5	M18×1.5	M20×1.5	M24×2
F	10	10	10	12	15
G1	50	55	60	65	75
G2	140	160	160	180	200
H	9	10	10	12	15
J	55	57	69	75	92
K	42	44	52	58	72
L	φ6.8-φ10.5 ×6.5D	φ6.8-φ10.5 ×6.5D	φ9-φ13.5 ×9D	φ9-φ13.5 ×9D	φ11-φ17 ×11D
M	18	22	26	32	40
N	20	22	26	30	37
O-Ring	P7	P7	P8	P8	P9
Q	φ18	φ20	φ22.4	φ28	φ35.5

Unit:mm

MODEL ITEM	CHS-32-M	CHS-40-M	CHS-50-M	CHS-63-M
ST:Swing/Clamping	29.5:14.5/15	44.5:14.5/30	29.5:14.5/15	44.5:14.5/30
A1 Unlamping	128	158	133	163
A2 Unlamping	154	185	160	190
B	95	110	100	115
C	30	30	34	34
D1	18	18	20	23
D2	31	31	37	48
D3	□22	□22	□25	□32
E1	M10	M10	M12	M16
E2	φ8	φ10	φ12	φ15
E3	M16×1.5	M18×1.5	M20×1.5	M24×2
F	10	10	12	15
G1	55	60	65	75
G2	160	160	180	200
H	10	10	12	15
φ1	φ50	φ54	φ66	φ80
J	56	63	72	88
K	44	48	57	70
L	φ6.8	φ9	φ9	φ11
M	PT1/8	PT1/8	PT1/4	PT1/4
N1	10	12	15	17
N2	19	19	21.5	22
N3	62	77	67	82
Q	φ20	φ22.4	φ28	φ35.5

**油路板附调速 MF-SM**

Single side swing clamp

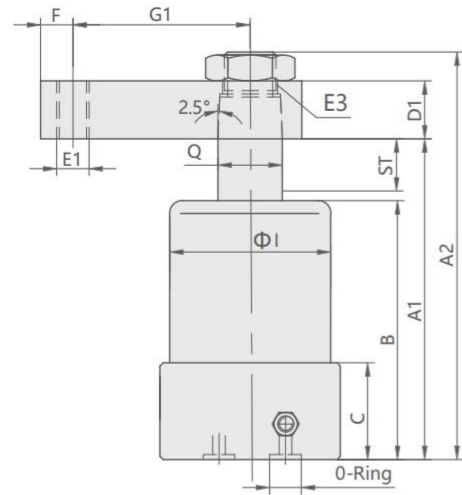

**油路板附调速MF-DM**

Double side swing clamp

注：下图为转角90°松开状态

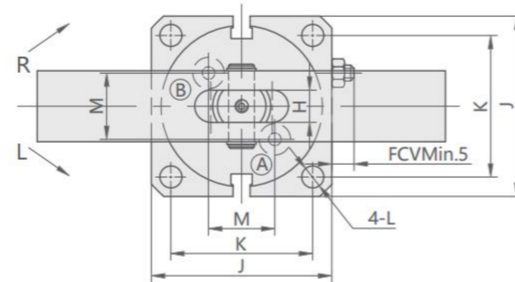
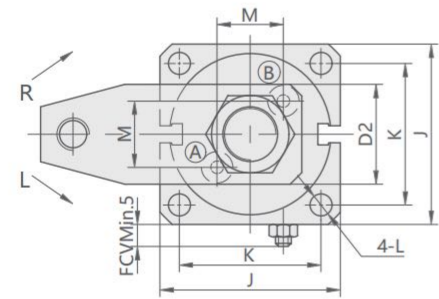
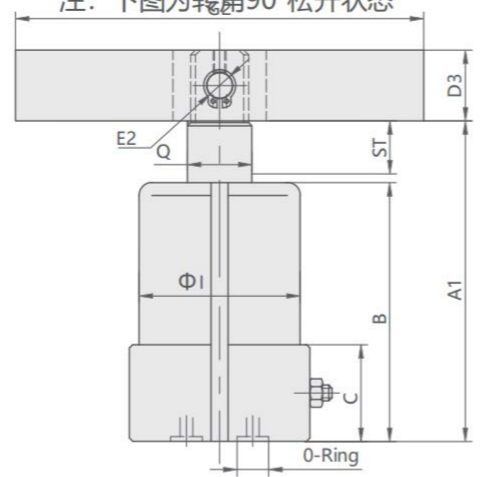

- Ⓐ 夹持油孔 Clamping port
- Ⓑ 放松油孔 Unclamping port

Unit:mm

MODEL ITEM	CHS-MF32-M	CHS-MF40-M	CHS-MF50-M	CHS-MF63-M
ST:Swing/Clamping	29.5:14.5/15	44.5:14.5/30	29.5:14.5/15	44.5:14.5/30
A1 Unlamping	128	158	133	163
A2 Unlamping	154	185	160	190
B	95	110	100	115
C	25	25	30	30
D1	18	18	20	23
D2	31	31	37	48
D3	□22	□22	□25	□32
E1	M10	M10	M12	M16
E2	∅8	∅10	∅12	∅15
E3	M16x1.5	M18x1.5	M20x1.5	M24x2
F	10	10	12	15
G1	55	60	65	75
G2	160	160	180	200
H	10	10	12	15
∅	∅50	∅54	∅66	∅80
J	57	63	72	88
K	44	48	57	70
L	∅6.8	∅9	∅9	∅11
M	21	23	28	32
O-Ring	P7	P9	P9	P9
Q	∅20	∅22.4	∅28	∅35.5

**油路板型 M-SM**

Single side swing clamp

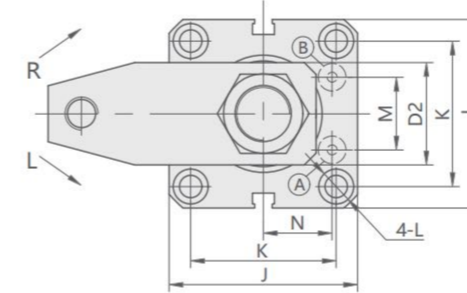
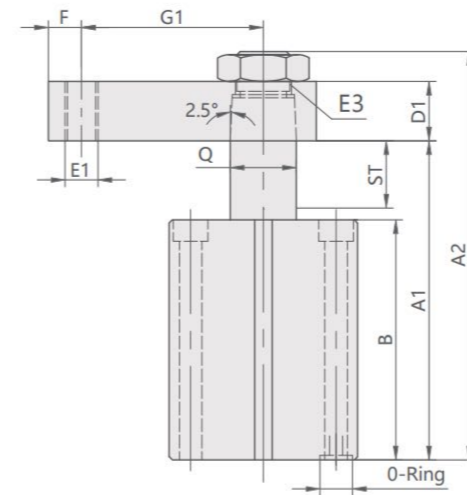

- Ⓐ 夹持油孔 Clamping port
- Ⓑ 放松油孔 Unclamping port

Unit:mm

MODEL ITEM	CHS-M32-M	CHS-M40-M	CHS-M50-M	CHS-M63-M
ST:Swing/Clamping	29.5:14.5/15	29.5:14.5/15	33:16/17	33:16/17
A1 Unlamping	128	133	147	152
A2 Unlamping	154	160	177	187
B	95	100	110	115
D1	18	18	20	23
D2	31	31	37	48
D3	□22	□22	□25	□32
E1	M10	M10	M12	M16
E2	∅8	∅10	∅12	∅15
E3	M16x1.5	M18x1.5	M20x1.5	M24x2
F	10	10	12	15
G1	55	60	65	75
G2	160	160	180	200
H	10	10	12	15
J	57	69	75	92
K	44	52	58	72
L	∅6.8-∅10.5x6.5D	∅9-∅13.5x9D	∅9-∅13.5x9D	∅11-∅17x11D
M	22	26	32	40
N	22	26	30	37
O-Ring	P7	P8	P8	P8
Q	∅20	∅22.4	∅28	∅35.5

### 法兰型FA-S

Single side swing clamp

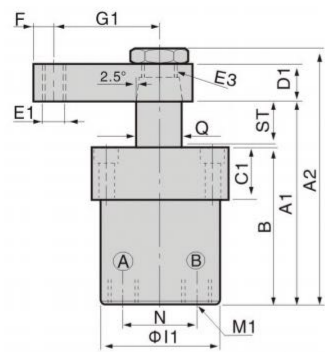

### 法兰型FA-D

Double side swing clamp  
注:下图为转角90°松开状态

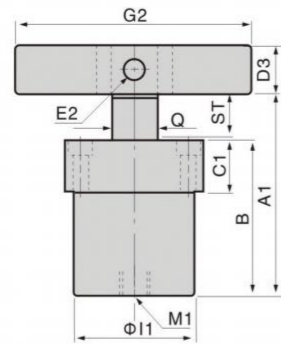

### 全牙型TB-S

Single side swing clamp

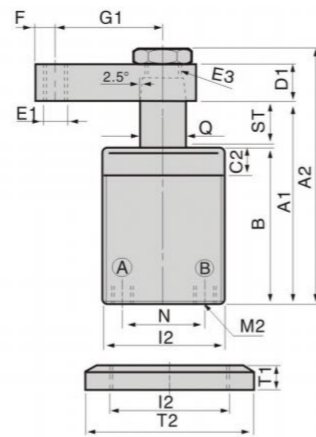

### 全牙型TB-D

Double side swing clamp  
注:下图为转角90°松开状态

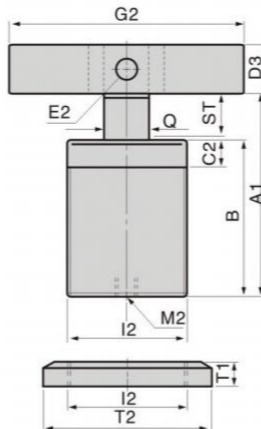

- Ⓐ 夹持油孔 Clamping port
- Ⓑ 放松油孔 Unclamping port

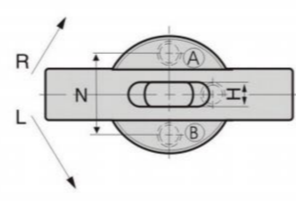
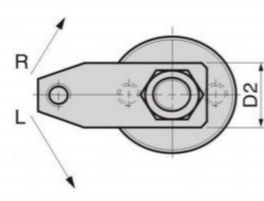
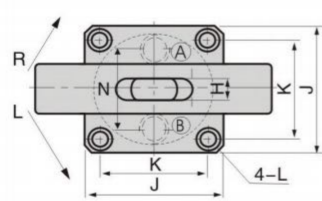
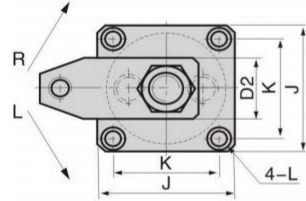

Unit:mm

### 法兰型油路板 FAM-S

Single side swing clamp

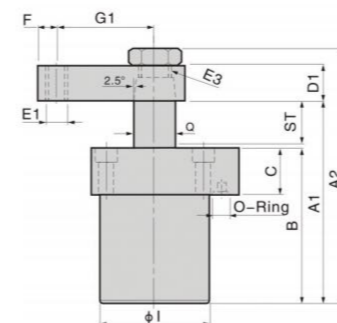

### 法兰型油路板 FAM-D

Double side swing clamp  
注:下图为转角90°松开状态

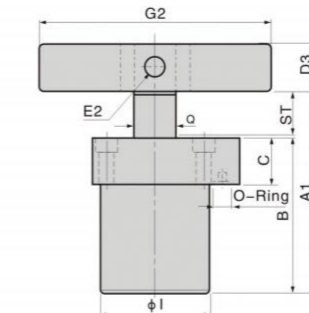

- Ⓐ 夹持油孔 Clamping port
- Ⓑ 放松油孔 Unclamping port

MODEL ITEM	CHS-FA25	CHS-FA32	CHS-FA40	CHS-FA50	CHS-FA63	CHS-TB25	CHS-TB32	CHS-TB40	CHS-TB50
------------	----------	----------	----------	----------	----------	----------	----------	----------	----------

ST:Swing /Clamping	24.5:11.5/13	29.5:14.5/15	29.5:14.5/15	33:16/17	33:16/17	24.5:11.5/13	29.5:14.5/15	29.5:14.5/15	33:16/17
A1 Unclamping	104	118	123	137	142	104	118	123	137
A2 Unclamping	127	144	150	167	177	127	144	150	167
B	76	85	90	100	105	76	85	90	100
C1	22	25	25	30	30	-	-	-	-
C2	-	-	-	-	-	12	12	15	15
D1	16	18	18	20	23	16	18	18	20
D2	27	31	31	37	48	27	31	31	37
D3	□19	□22	□22	□25	□32	□19	□22	□22	□25
E1	M10	M10	M10	M12	M16	M10	M10	M10	M12
E2	φ8	φ8	φ10	φ12	φ15	φ8	φ8	φ10	φ12
E3	M14×1.5	M16×1.5	M18×1.5	M20×1.5	M24×2	M14×1.5	M16×1.5	M18×1.5	M20×1.5
F	10	10	10	12	15	10	10	10	12
G1	50	55	60	65	75	50	55	60	65
G2	140	160	160	180	200	140	160	160	180
H	9	10	10	12	15	9	10	10	12
Φ11	φ45	φ50	φ58	φ68	φ81	-	-	-	-
I2	-	-	-	-	-	M45×1.5	M50×1.5	M55×1.5	M65×1.5
J	53	57	69	75	90	-	-	-	-
K	40	44	52	58	70	-	-	-	-
L	φ6.8-φ10.5×6.5D	φ6.8-φ10.5×6.5D	φ9-φ13.5×9D	φ9-φ13.5×9D	φ11-φ17×11D	-	-	-	-
M1	PT1/4	PT1/4	PT1/4	PT1/4	PT1/4	-	-	-	-
M2	-	-	-	-	-	PT1/8	PT1/8	PT1/8	PT1/8
N	28	32	40	50	63	28	32	40	50
T1×2PCS	-	-	-	-	-	10	11	11	12
T2	-	-	-	-	-	φ65	φ70	φ70	φ85
Q	φ18	φ20	φ22.4	φ28	φ35.5	φ18	φ20	φ22.4	φ28

### 法兰型油路板附调速FAMT-S

Single side swing clamp

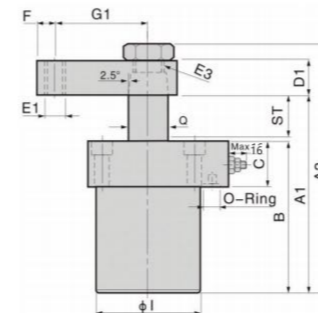

### 法兰型油路板附调速FAMT-D

Double side swing clamp  
注:下图为转角90°松开状态

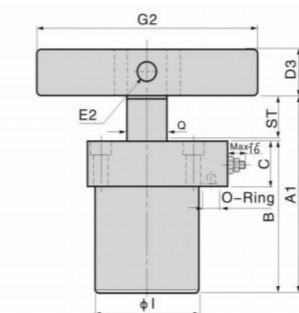

- Ⓐ 夹持油孔 Clamping port
- Ⓑ 放松油孔 Unclamping port

MODEL ITEM	CHS -FAM25	CHS -FAM32	CHS -FAM40	CHS -FAM50	CHS -FAM63
ST:Swing /Clamping	24.5:11.5/13	29.5:14.5/15	29.5:14.5/15	33:16/17	33:16/17
A1 Unclamping	104	118	123	137	142
A2 Unclamping	127	144	150	167	177
B	76	85	90	100	105
C	22	25	25	30	30
D1	16	18	18	20	23
D2	27	31	31	37	48
D3	□19	□22	□22	□25	□32
E1	M10	M10	M10	M12	M16
E2	φ8	φ8	φ10	φ12	φ15
E3	M14×1.5	M16×1.5	M18×1.5	M20×1.5	M24×2
F	10	10	10	12	15
G1	50	55	60	65	75
G2	140	160	160	180	200
H	9	10	10	12	15
Φ1	φ45	φ50	φ58	φ68	φ81
J1	55	57	69	75	90
J2	64	65.5	79	87	104.5
K	42	44	52	58	70
L	φ6.8-φ10.5 ×6.5D	φ6.8-φ10.5 ×6.5D	φ9-φ13.5 ×9D	φ9-φ13.5 ×9D	φ11-φ17 ×11D
M	20	22	26	30	32
N	28	29	34.5	39	46
O-Ring	P6	P6	P9	P9	P9
Q	φ18	φ20	φ22.4	φ28	φ35.5

MODEL ITEM	CHS -FAMT25	CHS -FAMT32	CHS -FAMT40	CHS -FAMT50	CHS -FAMT63
ST:Swing /Clamping	24.5:11.5/13	29.5:14.5/15	29.5:14.5/15	33:16/17	33:16/17
A1 Unclamping	104	118	123	137	142
A2 Unclamping	127	144	150	167	177
B	76	85	90	100	105
C	22	25	25	30	30
D1	16	18	18	20	23
D2	27	31	31	37	48
D3	□19	□22	□22	□25	□32
E1	M10	M10	M10	M12	M16
E2	φ8	φ8	φ10	φ12	φ15
E3	M14×1.5	M16×1.5	M18×1.5	M20×1.5	M24×2
F	10	10	10	12	15
G1	50	55	60	65	75
G2	140	160	160	180	200
H	9	10	10	12	15
Φ1	φ45	φ50	φ58	φ68	φ81
J1	55	57	69	75	90
J2	64	65.5	77	87	104.5
K	42	44	52	58	70
L	φ6.8-φ10.5 ×6.5D	φ6.8-φ10.5 ×6.5D	φ9-φ13.5 ×9D	φ9-φ13.5 ×9D	φ11-φ17 ×11D
M	20	22	26	30	32
N	28	29	34.5	39	46
O-Ring	P6	P6	P6	P9	P9
Q	φ18	φ20	φ22.4	φ28	φ35.5
Z	27.5	28.5	34.5	37.5	45

# CPF

## 平行油压转角缸

### CPF HYDRAULIC SWING CLAMP



#### 产品特性

此系列产品配件采用优化设计,使体积更加紧凑,提高了产品强度。产品采用了专用防尘设计,提高了防尘和密封性,实现了高密封性。  
产品平行转角设计节省了空间,适合夹具要求的紧凑化。

最大操作压力: 45kgf/cm<sup>2</sup>  
最小操作压力: 20kgf/cm<sup>2</sup>  
作动方式: 复动式

#### FEATURES

The accessories of the CPF series are optimally designed to create a more compact-sized product with enhanced strength. With its special dust-proof design, this product has improved its sealing performance and protects against any particles or debris while in use. With its design to swing horizontally, this series is able to achieve space efficiency required when designing fixtures.

Max.operating pressure: 45kgf/cm<sup>2</sup>  
Max.operating pressure: 20kgf/cm<sup>2</sup>  
Double acting

#### 剖面图 Sectional view

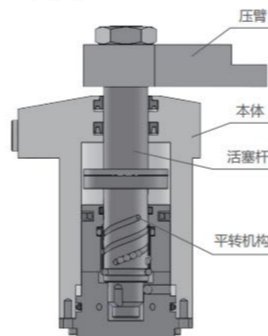

#### 注意事项

夹紧及放松作动速度需适当放缓。  
特殊压臂长度及重量不得超过标准压臂的1.5倍。  
压臂旋转示意图及安装拆卸方式,请参见第4页。

#### NOTE

The action and the speed of clamping / unclamping needs to be slowed down appropriately.  
The length and weight of the customized clamping arm shall not exceed 1.5 times of the standard clamping arm.  
Please refer to page 4 for the rotation diagram, installation instructions and removal methods of the clamping arm.

#### 订购标示法 ORDERING INDICATION

##### 示例: CPF-35DL-90G

CPF	系列 Series	CPF
35	油缸内径 Hydraulic cylinder inside diameter	Φ35, Φ40
D	安装方式 Installation	U:上法兰安装 On flange installation D:下法兰安装 Base flange installation
L	转角方向 Swing direction	右转R或左转L Turn right R or turn left L
90	转角角度 Swing angle	标准角度 Standard angle 90°(±2°) 订做角度 Order angle 0°, 45°(±2°), 60°(±2°)
G	型式 Type	空白: 配管式 Line type G: 油路板型 Manifold type

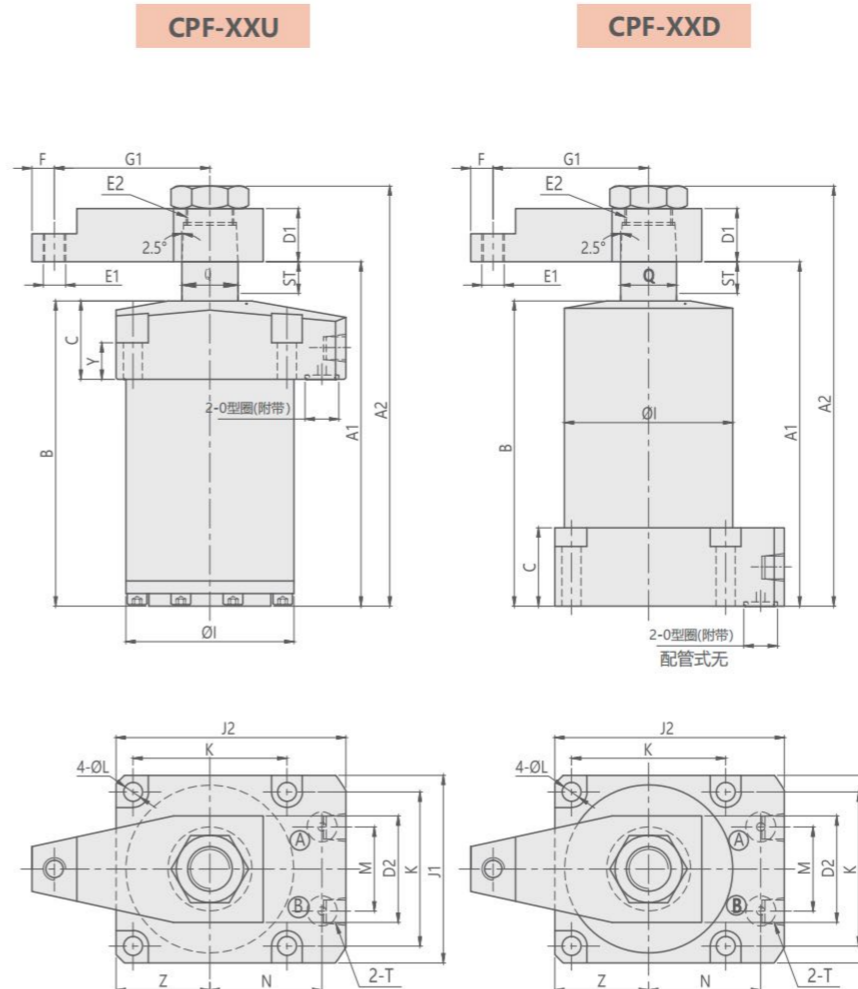
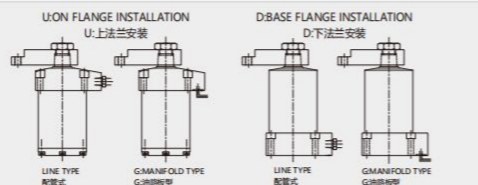

Ⓐ 夹持油孔 Clamping port  
Ⓑ 放松油孔 Unclamping port

Unit:mm

MODEL ITEM	CPF-35U	CPF-40U	CPF-35D	CPF-40D
行程Stroke	10	10	10	10
A1松开状态 Unclamp	114	123	114	123
A2松开状态 Unclamp	141	150	141	150
B	96	109	96	109
C	28	28	28	28
D1	19	19	19	19
D2	38	38	38	38
E1	M6	M8	M6	M8
E2	M16X1.5	M16X1.5	M16X1.5	M16X1.5
F	6	8	6	8
G1	46.5	55.5	46.5	55.5
I	Φ50	Φ60	Φ50	Φ60
J1	59	67	59	67
J2	72	82	72	82
K	47	55	47	55
L	Φ6.8	Φ6.8	Φ6.8	Φ6.8
M	24	30	24	30
N	34	40	34	40
T	PT1/8	PT1/8	PT1/8	PT1/8
Y	16	16	16	16
Z	29.5	33.5	29.5	33.5
Q	Φ20	Φ20	Φ20	Φ20
O型圈(仅G型) O-Ring(G type)	P6	P9	P6	P9

#### 规格参数表 SPECIFICATIONS

型号	理论夹持力 (45 kgf/cm <sup>2</sup> )	夹紧行程	总行程	推出容积	拉入容积	推出受压面积	拉入受压面积	使用温度范围	使用流体
MODEL	CLAMPING FORCE AT 45 kgf/cm <sup>2</sup> (kgf)	CLAMPING STROKE (mm)	TOTAL STROKE(mm)	CYLINDER CAPACITY UNCLAMP(cm <sup>3</sup> )	CYLINDER CAPACITY CLAMP(cm <sup>3</sup> )	EFFPISTON AREA UNCLAMP(cm <sup>2</sup> )	EFFPISTON AREA CLAMP(cm <sup>2</sup> )	RANGE OF TEMPERATURE(°C)	USABLE FLUID
CPF-35	291	10	10	6.47	6.47	6.47	6.47	-10~+70°C	相当于ISO黏度等级的ISO-VG-32一般液压油 Recommended: ISO-VG-32 hydraulic oil equivalent to ISO viscosity grade
CPF-40	424	10	10	9.43	9.43	9.43	9.43	-10~+70°C	

# CTLA

## 高压转角缸

# CTLA HIGH PRESSURE HYDRAULIC SWING CLAMP



### 产品特性

优良的结构设计,大幅扩大了压板长度的使用范围,适合高速动作的耐久性,有优异的防冷却液侵入结构,可以直接安装速度控制阀。

最大操作压力: 350kgf/cm<sup>2</sup>  
最小操作压力: 70kgf/cm<sup>2</sup>

### FEATURES

Excellent structural design, greatly expand the use of the length of the plate, suitable for high-speed action durability, With excellent anti-coolant intrusion structure, speed control valves can be installed directly.

Max.operating pressure:350kgf/cm<sup>2</sup>  
Min.operating pressure:70kgf/cm<sup>2</sup>

### 订购标示法 ORDERING INDICATION

示例: CTLA-0402CR

CTLA	系列 Series	CTLA
0402	主体尺寸 Body size	0402: ØD=28.5mm 1002: ØD=43mm 0602: ØD=33mm 1602: ØD=46mm 0802: ØD=36mm 2502: ØD=63mm 4002: ØD=90mm
C	配管方式 Piping Method	B: 外配管型 (G螺纹,无板式连接口) B: G Thread Piping Option(No Gasket Port) C: 板式连接型(附带G螺纹堵头) C: Gasket Option(With G Thread Plug)
R	夹紧时的旋转方向 Swing direction when Clamping	R:顺时针方向 R:Turn right L:逆时针方向 L:Turn left

注: 速度控制阀(CZT)由用户另行购买 Note: Speed control valve(CZT) is sold separately.

### 规格参数表 SPECIFICATIONS

型号	理论夹持力 (350kgf/cm <sup>2</sup> )	夹紧行程	转角行程	总行程	推出容积	拉入容积	推出受压面积	拉入受压面积	使用温度范围
MODEL	CLAMPING FORCE AT 350kgf/cm <sup>2</sup> (kgf)	CLAMPING STROKE(mm)	EXTRA STROKE(mm)	TOTAL STROKE(mm)	CYLINDER CAPACITY UNCLAMP(cm <sup>3</sup> )	CYLINDER CAPACITY CLAMP(cm <sup>3</sup> )	EFF.PISTON AREA UNCLAMP(cm <sup>2</sup> )	EFF.PISTON AREA CLAMP(cm <sup>2</sup> )	RANGE OF TEMPERATURE(°C)
CTLA-0402	350	8	6	14	3.6	1.4	2.545	1.005	0~+70°C
CTLA-0602	508	8	7	15	5.2	2.2	3.463	1.453	0~+70°C
CTLA-0802	690	10	8	18	8.1	3.6	4.524	1.979	0~+70°C
CTLA-1002	980	10	9.5	19.5	12.9	5.5	6.605	2.804	0~+70°C
CTLA-1602	1459	13	11	24	21.8	10	9.079	4.17	0~+70°C
CTLA-2502	2869	16	16	32	57.9	26.2	18.096	8.198	0~+70°C
CTLA-4002	4329	16	19.5	35.5	100.4	43.9	28.274	12.37	0~+70°C

### 外形尺寸 External Dimensions

C: 板式连接型(附带G螺纹堵头) C: Gasket Option(With G Thread Plug)  
※本图表示CTLA-2CL型的释放状态。  
※The drawing shows the released state of CTLA-2CL.

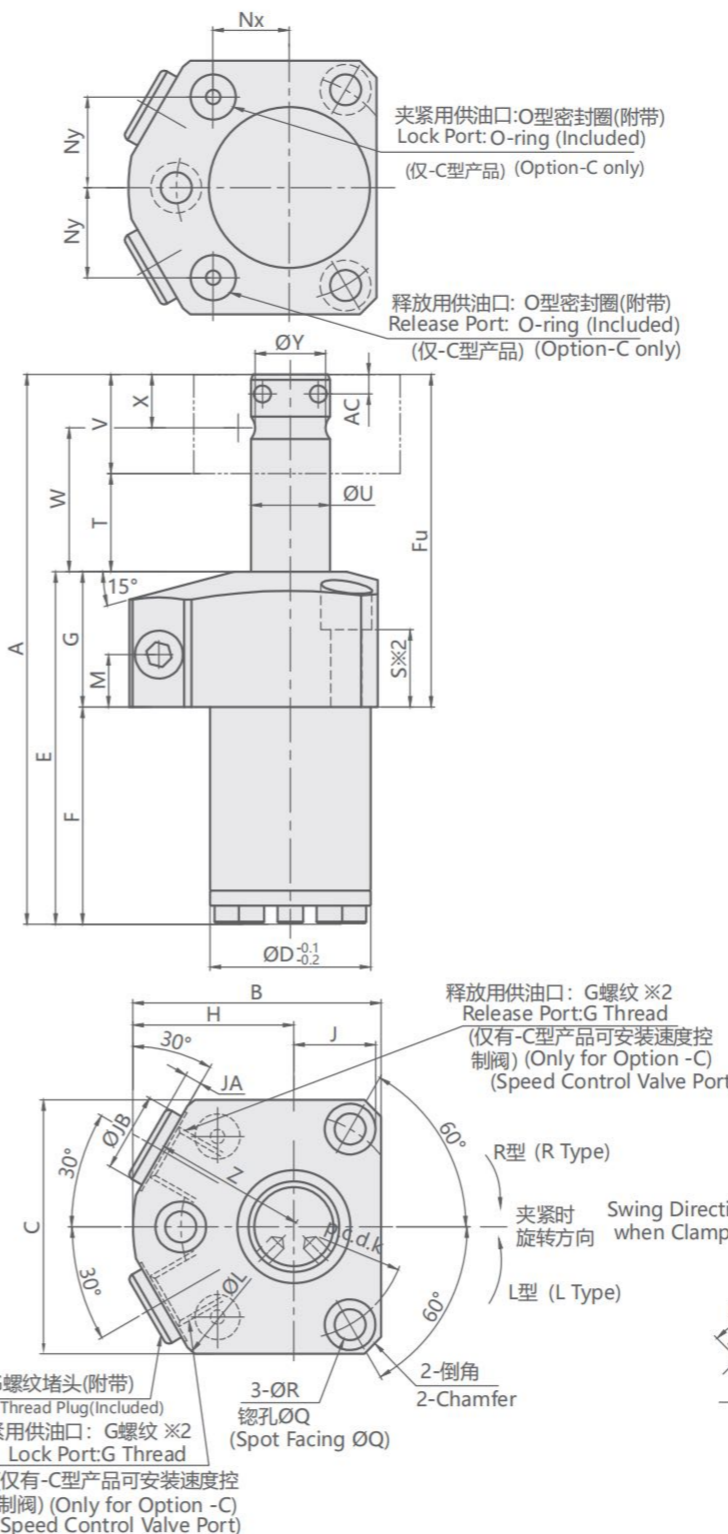

### 注意事项

- ※1本产品未附带安装螺栓,请用户参考S尺寸并根据安装高度自行配备。
- ※2本产品未附带速度控制阀,请用户自行配备。
- ※3请参考S尺寸并根据安装高度决定安装螺栓的CA螺纹深度。
- ※4请参考F尺寸,并根据安装高度决定本体安装孔ØD的深度。
- ※5本加工表示-C: 板式连接型的情况。

### 安装部位加工尺寸 Machining Dimensions of Mounting Area

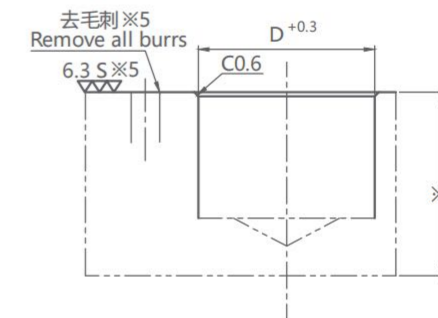
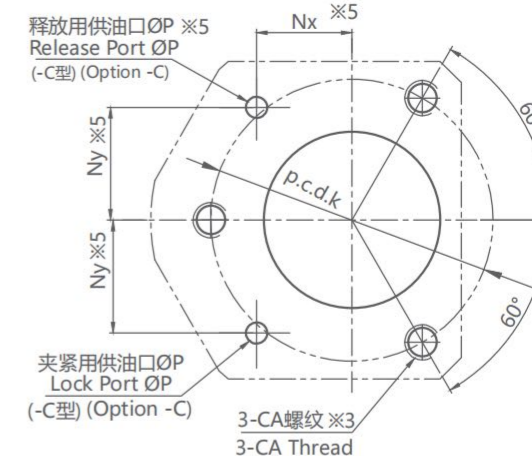

夹紧状态 Lock State

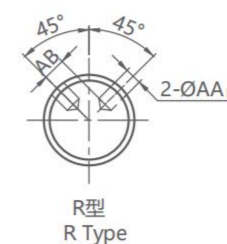
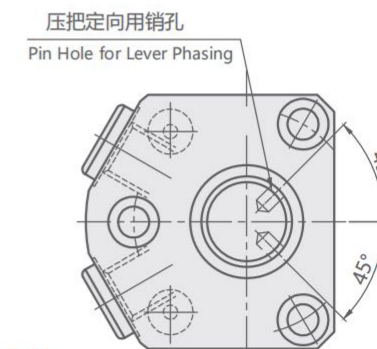

### NOTE

- ※1.Mounting bolts are not provided. Please prepare them according to the mounting height referring to dimension'S'.
- ※2.Speed control valve is sold separately.
- ※3.CA tapping depth of the mounting bolt should be decided according to the mounting height referring to dimension'S'.
- ※4.The depth of the body mounting hole ØD should be decided according to the mounting height referring to dimension'F'.
- ※5.The machining dimension is for -C:Gasket option.

型号 MODEL NO	CTLA-0402□□	CTLA-0602□□	CTLA-0802□□	CTLA-1002□□	CTLA-1602□□
全行程 Full Stroke	14	15	18	19.5	24
转角行程 Swing Stroke	6	7	8	9.5	11
夹紧行程 Lock Stroke	8	8	10	10	13
A	97.5	105	119	134.5	159.5
B	44	48	50.5	59.5	62
C	45	52	54	65	68
D	28.5	33	36	43	46
E	62.5	66	74	83	99.5
F	38.5	41	49	55	69.5
Fu	59	64	70	79.5	90
G	24	25	25	28	30
H	28.5	30	31.5	36.5	38
J	15.5	18	19	23	24
K	40	45	48	57	60
L	57	60	63	73	76
M	10	10	10	10	10
Nx	13.5	15	16	18	20
Ny	16	17.5	18.5	22	22
P	3	3	3	3	3
Q	9	11	11	14	14
R	5.5	6.8	6.8	9	9
S	14.5	14	14	14.5	16
T	16	17	20	21.5	26
U	14	16	18	22	25
V	19	22	25	30	34
W	25.5	28	32.5	36.5	43
X	9.5	11	12.5	15	17
Y	12.5	14	16	19.5	22
Z	27	28.5	30	33	35
AA	3 <sup>+0.014</sup> <sub>0</sub>	4 <sup>+0.018</sup> <sub>0</sub>	4 <sup>+0.018</sup> <sub>0</sub>	4 <sup>+0.018</sup> <sub>0</sub>	4 <sup>+0.018</sup> <sub>0</sub>
AB	4	4	5	7	8.5
AC	3.5	4.5	4.5	4.5	5
CA(Nominal X Pitch)	M5×0.8	M6×1	M6×1	M8×1.25	M8×1.25
JA	3	3	3	3	3
JB	14	14	14	14	14
倒角 Chamfer	3	(Φ60)	(Φ63)	(Φ73)	(Φ76)
G 螺纹 G Thread	G1/8	G1/8	G1/8	G1/8	G1/8
O型密封 (-C型) O-ring(Option-C)	1BP5	1BP5	1BP5	1BP5	1BP5
压板定向销 (附带) (Lever Phasing Pin (Included))	Φ3×6	Φ4×8	Φ4×8	Φ4×8	Φ4×8

## 外形尺寸 External Dimensions

## CTLA-2502/CTLA-4002

C: 板式(附带G螺纹堵头) C: Gasket Option(With G Thread Plug)  
※本图表示CTLA-2CL型的释放状态。

※The drawing shows the released state of CTLA-2CL.

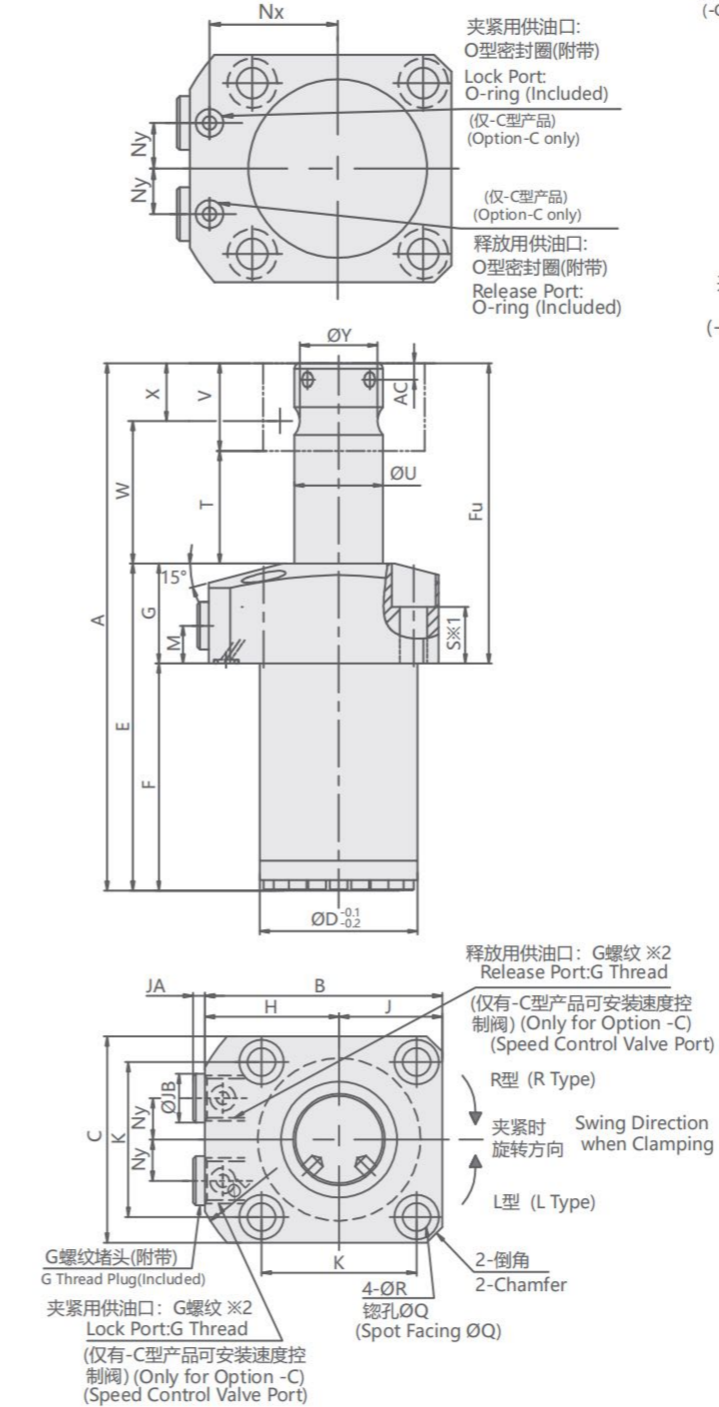
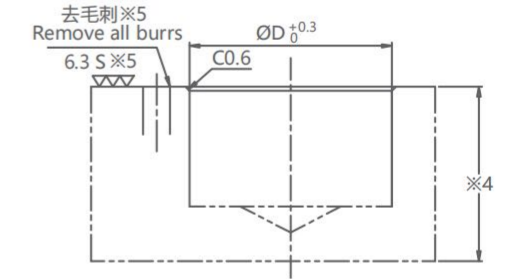
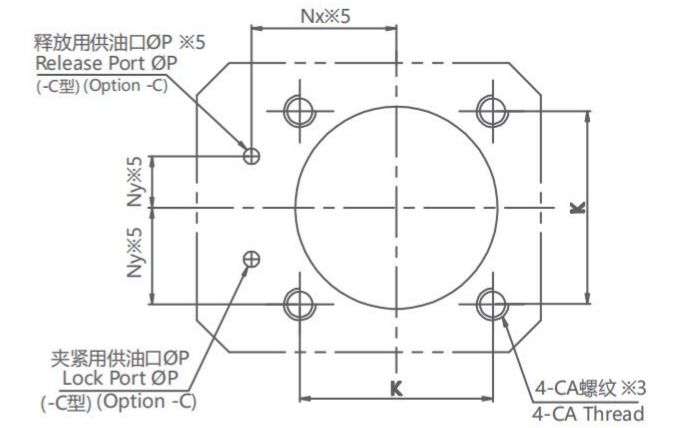
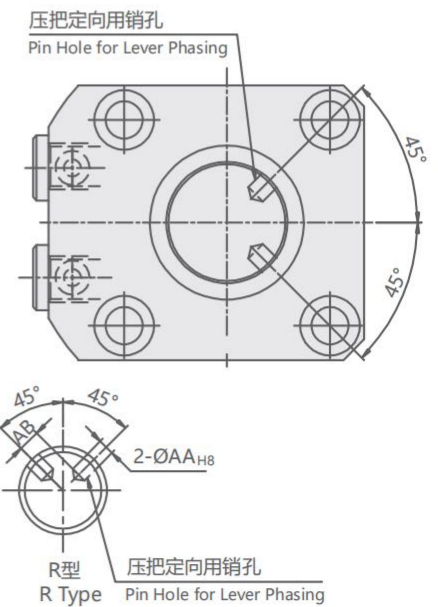
安装部位加工尺寸  
Machining Dimensions of Mounting Area夹紧状态  
Lock State

## 注意事项

- ※1.本产品未附带安装螺栓。请用户参考S尺寸并根据安装高度自行配备。
- ※2.本产品未附带速度控制阀。请用户自行配备。
- ※3.请参考S尺寸并根据安装高度决定安装螺栓的CA螺纹深度。
- ※4.请参考F尺寸,并根据安装高度决定本体安装孔ØD的深度。
- ※5.本加工表示-C: 板式连接型的情况。

## NOTE

- ※1. Mounting bolts are not provided. Please prepare them according to the mounting height referring to dimension "S".
- ※2. Speed control valve is sold separately.
- ※3. CA tapping depth of the mounting bolt should be decided according to the mounting height referring to dimension "S".
- ※4. The depth of the body mounting hole ØD should be decided according to the mounting height referring to dimension "F".
- ※5. The machining dimension is for -C: Gasket option.

Unit:mm

型号 MODEL NO	CTLA-2502□□	CTLA-4002□□
全行程 Full Stroke	32	35.5
转角行程 Swing Stroke	16	19.5
夹紧行程 Lock Stroke	16	16
A	211	241
B	92	114
C	80	102
D	63	90
E	131	148.5
F	91	98.5
Fu	120	142.5
G	40	50
H	52	63
J	40	51
K	60	80
L	118	146
M	15	17
Nx	45	56
Ny	16	21
P	5	5
Q	17.5	20
R	11	14
S	22.5	27.5
T	34	37.5
U	35.5	45
V	46	55
W	57	65
X	23	27.5
Y	31	39.5
AA	$6_0^{+0.018}$	$8_0^{+0.018}$
AB	11.75	14.5
AC	6.5	9
CA	M10	M12
JA	4.5	4.5
JB	19	19
倒角 Chamfer	C6	C6
G 螺纹 G Thread	G1/4	G1/4
O型密封 (-C型) O-ring(Option-C)	1BP7	1BP7
压板定向销 (附带) (Lever Phasing Pin (Included))	Φ6×12	Φ8×16



# CTLA-M

## 复动高压气压检测转角缸

### CTLA-M DOUBLE ACTING WITH HIGH PRESSURE AIR SENSING SWING CLAMP



#### 产品特性

优良的结构设计，大幅扩大了压板长度的使用范围，适合高速动作的耐久性，有优异的防冷却液侵入结构，通过连接空气传感器，检出压差，实现确认动作。可以直接安装速度控制阀。

最大操作压力：350kgf/cm<sup>2</sup>

最小操作压力：70kgf/cm<sup>2</sup>

#### FEATURES

Excellent structural design, greatly expand the use of the length of the plate, suitable for high-speed action durability. With excellent anti-coolant intrusion structure, By connecting an air sensor, the pressure difference is detected to achieve the confirmation action. Speed control valves can be installed directly.

Max.operating pressure:350kgf/cm<sup>2</sup>

Min.operating pressure:70kgf/cm<sup>2</sup>

#### 注意事项

夹紧及放松动作速度需适当放缓，压臂尺寸见后面压臂参数表。为进行确认动作，须设置空气传感器。气口须进行大气开放，务必防止冷却液，切削渣的侵入。使用时请保持向气口常态供气状态。

#### NOTE

The speed of clamping and unclamping action needs to be slowed down appropriately. Please refer to page 132 for the damping arm dimensions. Action confirmation can be conducted by detecting differential pressure with the air sensor. Please keep clearance of the air exhaust hole to prevent the intrusion of coolant and chips. Make sure to supply constant air pressure to the air port when in use.

#### 订购标示法 ORDERING INDICATION

##### 示例: CTLA-1002CRM

CTLA	系列 Series	CTLA
1002	主体尺寸 Body size	1002: ΦD=43mm 1602: ΦD=46mm (ΦD表示本体油缸法兰下部的外径尺寸) (Outer diameter (ΦD) of the cylinder)
C	配管方式 Piping Method	C:板式连接型(附带G螺纹堵头) C:Gasket Option(With G Thread Plug)
R	夹紧时的旋转方向 Swing direction when Clamping	R:顺时针方向 R:Turn right L:逆时针方向 L:Turn left
M	空气检测器板式连接型 Air detector board connection type	

注：速度控制阀(CZT)由用户另行购买 Note:Speed control valve(CZT) is sold separately.

#### 规格参数表 SPECIFICATIONS

型号	理论夹持力 350kgf/cm <sup>2</sup>	转角行程	夹紧行程	总行程	推出容积	拉入容积	推出受压面积	拉入受压面积	使用温度范围
MODEL	CLAMPING FORCE AT 350kgf/cm <sup>2</sup> (kgf)	SWING STROKE (mm)	CLAMPING STROKE (mm)	TOTAL STROKE(mm)	CYLINDER CAPACITY UNCLAMP(cm <sup>3</sup> )	CYLINDER CAPACITY CLAMP(cm <sup>3</sup> )	EFF.PISTON AREA UNCLAMP(cm <sup>2</sup> )	EFF.PISTON AREA CLAMP(cm <sup>2</sup> )	RANGE OF TEMPERATURE(°C)
CTLA-1002C□M	980	9.5	10	19.5	12.9	5.5	6.605	2.804	0~+70°C
CTLA-1602C□M	1459	11	13	24	21.8	10	9.079	4.170	0~+70°C

#### 外形尺寸 External Dimensions

C: 板式(附带G螺纹堵头)  
※本图表示CTLA-2CLM型的释放状态。  
其余尺寸参考CTLA系列参数。

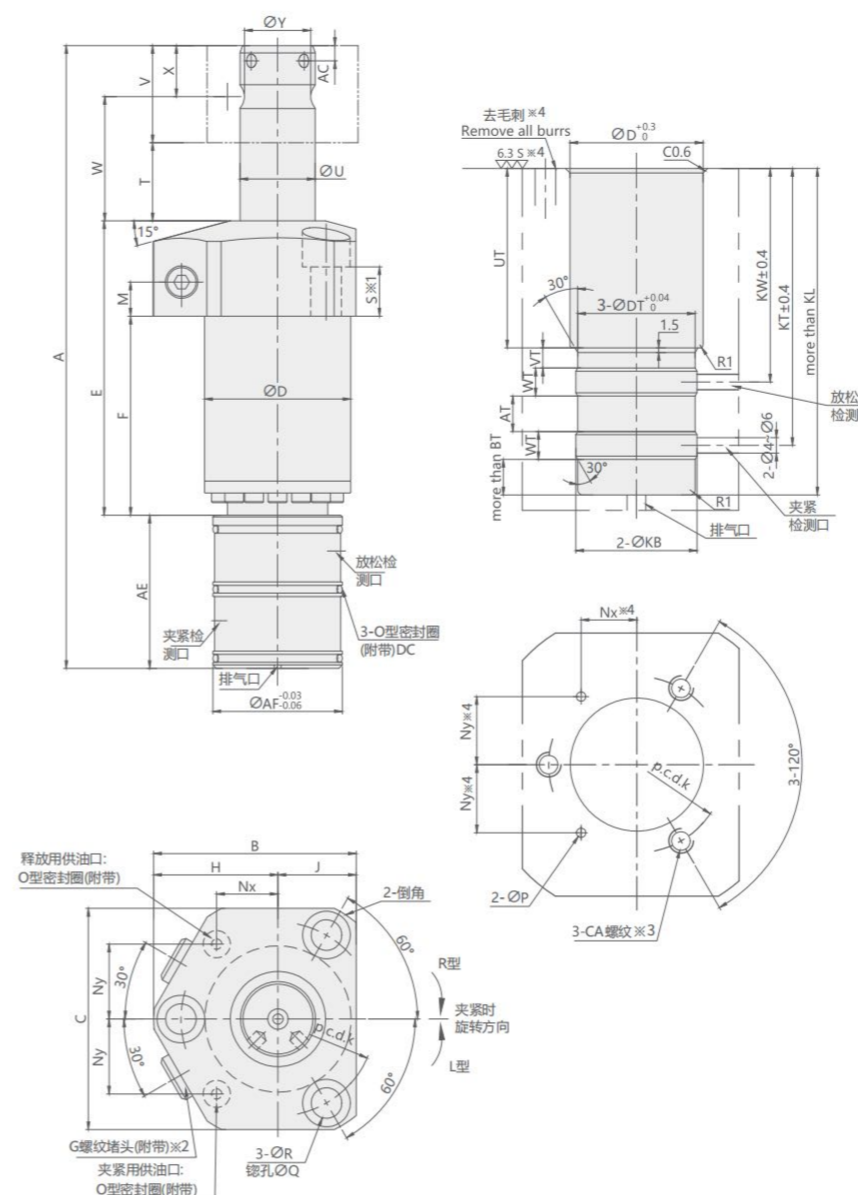

#### 注意事项

- ※1.本产品未附带安装螺栓。请用户参考S尺寸并根据安装高度自行配备。
- ※2.本产品未附带速度控制阀。请用户自行配备。
- ※3.请参考S尺寸并根据安装高度决定安装螺栓的CA纹深度。
- ※4.本加工表示-C:板式连接型的情况。

#### NOTE

- ※1.Mounting bolts are not provided. Please prepare them according to the mounting height referring to dimension'S'.
- ※2.Speed control valve is sold separately.
- ※3.CA tapping depth of the mounting bolt should be decided according to the mounting height referring to dimension'S'.
- ※4.The machining dimension is for -C:Gasket option.

#### 安装部位加工尺寸 Machining Dimensions of Mounting Area

Unit:mm

型号 MODEL	CTLA-1002C□M	CTLA-1602C□M
全行程 Full Stroke	19.5	24
转角行程 Swing Stroke	9.5	11
夹紧行程 Lock Stroke	10	13
A	183	208
B	59.5	62
C	65	68
D	43	46
E	86.5	103
F	58.5	73
H	36.5	38
J	23	24
M	10	10
Nx	18	20
Ny	22	22
P	3	3
Q	14	14
R	9	9
S	14.5	16
T	21.5	26
U	22	25
V	30	34
W	36.5	43
X	15	17
Y	19.5	22
AE	45	45
AC	4.5	5
AF	38	38
K	57	60
CA	M8	M8
UT	58	72
DT	38	38
VT	6.5	7
WT	9	9
BT	11.5	11.5
KW	69	83.5
KT	89.5	104
KL	105.5	120
DC	AS568-028(70°)	
倒角 Chamfer	Φ73	Φ76
G 螺纹 G Thread	G1/8	G1/8
O型密封 (-C型) O-ring (Option-C)	1BP5	1BP5
压板定向销 (附带) (Lever Phasing Pin (Included))	Φ4×8	Φ4×8

# CTLB

## 高压转角缸

# CTLB HIGH PRESSURE HYDRAULIC SWING CLAMP



### 产品特性

优良的结构设计,大幅扩大了压板长度的使用范围,适合高速动作的耐久性,有优异的防冷却液侵入结构,可以直接安装速度控制阀。

最大操作压力: 350kgf/cm<sup>2</sup>  
最小操作压力: 70kgf/cm<sup>2</sup>

### 注意事项

夹紧及放松动作速度需适当放缓,压臂尺寸见后面压臂参数表。

### FEATURES

Excellent structural design, greatly expand the use of the length of the plate, suitable for high-speed action durability, With excellent anti-coolant intrusion structure, speed control valves can be installed directly.

Max.operating pressure:350kgf/cm<sup>2</sup>  
Min.operating pressure:70kgf/cm<sup>2</sup>

### NOTE

The action and the speed of clamping/unclamping needs to be slowed down appropriately.The size of the press arm is shown in the press arm parameters at the back.

### 订购标示法 ORDERING INDICATION

示例: CTLB-0402CR

CTLB	系列 Series	CTLB	
0402	主体尺寸 Body size	0402: ΦD=32mm	1602: ΦD=53mm
		0602: ΦD=36mm	2502: ΦD=71mm
		0802: ΦD=39mm	4002: ΦD=90mm
		1002: ΦD=46.5mm	
		(ΦD表示本体油缸法兰下部的外径尺寸) (Outer diameter (ΦD) of the cylinder)	
C	配管方式 Piping Method	C:板式连接型(附带G螺纹堵头) C:Gasket Option(With G Thread Plug)	
R	夹紧时的旋转方向 Swing direction when Clamping	R:顺时针方向 L:逆时针方向	R:Turn right L:Turn left

注: 速度控制阀(CZT)由用户另行购买 Note:Speed control valve(CZT) is sold separately.

### 规格参数表 SPECIFICATIONS

型号	理论夹持力 (350kgf/cm <sup>2</sup> )	夹紧行程	转角行程	总行程	推出容积	拉入容积	推出受压面积	拉入受压面积	使用温度范围
MODEL	CLAMPING FORCE AT 350kgf/cm <sup>2</sup> (kgf)	CLAMPING STROKE(mm)	EXTRA STROKE(mm)	TOTAL STROKE(mm)	CYLINDER CAPACITY UNCLAMP(cm <sup>3</sup> )	CYLINDER CAPACITY CLAMP(cm <sup>3</sup> )	EFF.PISTON AREA UNCLAMP(cm <sup>2</sup> )	EFF.PISTON AREA CLAMP(cm <sup>2</sup> )	RANGE OF TEMPERATURE(°C)
CTLB-0402	350	8	6	14	3.6	1.4	2.545	1.005	0~+70°C
CTLB-0602	508	8	7	15	5.2	2.2	3.463	1.453	0~+70°C
CTLB-0802	690	10	8	18	8.1	3.6	4.524	1.979	0~+70°C
CTLB-1002	980	10	9.5	19.5	12.9	5.5	6.605	2.804	0~+70°C
CTLB-1602	1459	13	11	24	21.8	10	9.079	4.170	0~+70°C
CTLB-2502	2869	16	16	32	57.9	26.2	18.096	8.198	0~+70°C
CTLB-4002	4329	16	19.5	35.5	100.4	43.9	28.274	12.370	0~+70°C

### 外形尺寸 External Dimensions

C: 板式(附带G螺纹堵头) C: Gasket Option(With G Thread Plug)  
※本图表示CTLB-2CL型的释放状态。  
※The drawing shows the released state of CTLB-2CL.

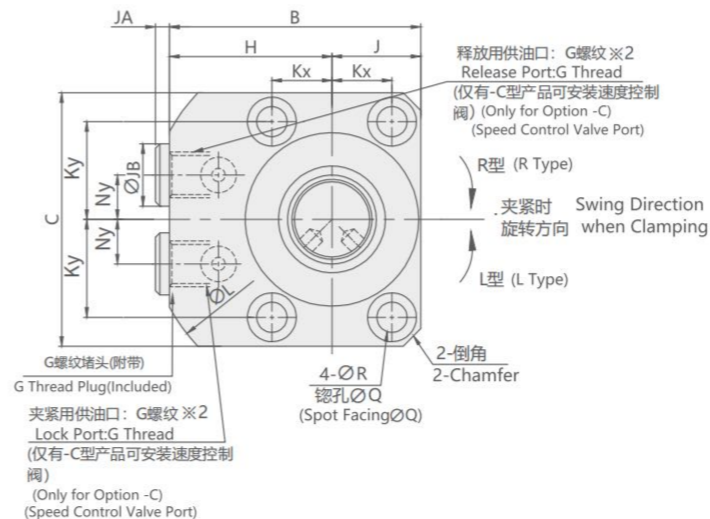
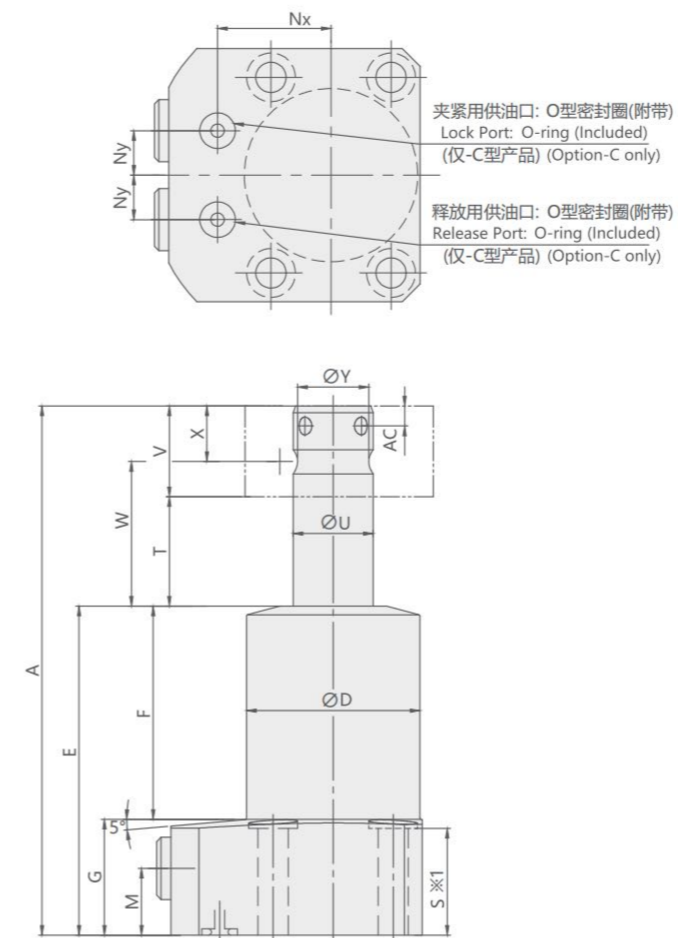

### 安装部位加工尺寸 Machining Dimensions of Mounting Area

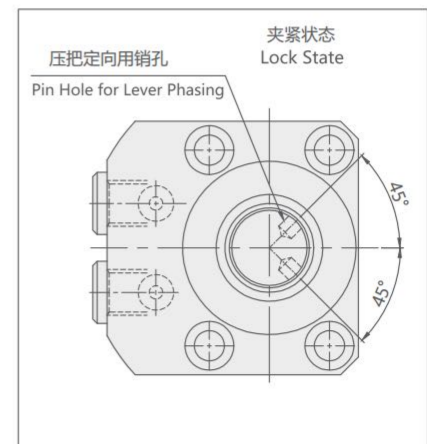
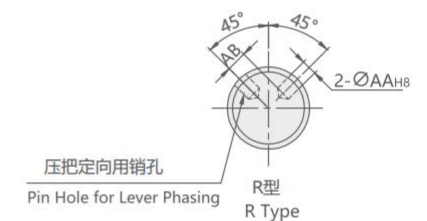
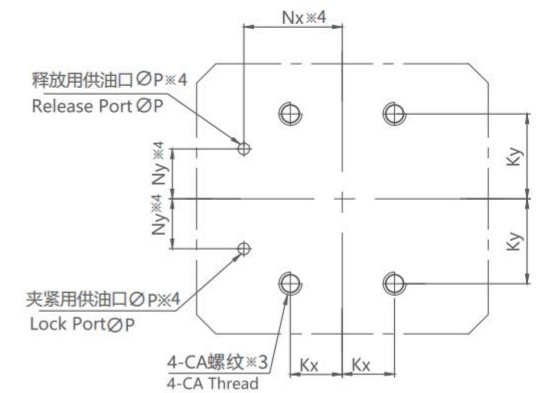

### 注意事项

- ※1本产品未附带安装螺栓。请用户参考S尺寸并根据安装高度自行配备。
- ※2本产品未附带速度控制阀。请用户自行配备。
- ※3.请参考S尺寸并根据安装高度决定安装螺栓的CA螺纹深度。
- ※4.本加工表示-C: 板式连接型的情况。

### NOTE

- ※1.Mounting bolts are not provided . Please prepare them according to the mounting height referring to dimension "S".
- ※2.Speed control valve is sold separately.
- ※3.CA tapping depth of the mounting bolt should be decided according to the mounting height referring to dimension "S".
- ※4.The machining dimension is for -C:Gasket option.

Unit:mm

型号 MODEL NO	CTLB-0402□□	CTLB-0602□□	CTLB-0802□□	CTLB-1002□□	CTLB-1602□□	CTLB-2502□□	CTLB-4002□□
全行程 Full Stroke	14	15	18	19.5	24	32	35.5
转角行程 Swing Stroke	6	7	8	9.5	11	16	19.5
夹紧行程 Lock Stroke	8	8	10	10	13	16	16
A	97.5	105	119	134.5	159.5	211	241
B	49.5	53.5	56.5	64	71.5	99.5	118
C	47	55	57	70	71	84	102
D	32	36	39	46.5	53	71	90
E	62.5	66	74	83	99.5	131	148.5
F	36.5	40	48	57	72.5	101	112.5
G	26	26	26	26	27	30	36
H	33	35	36.5	40	43.5	57.5	67
J	16.5	18.5	20	24	28	42	51
Kx	11	12	13.5	16	20	32	40
Ky	18	21	22	27	27.5	32	40
L	76	78	83	93	98	132	148
M	15	15	15	15	16	16.5	22.5
Nx	22	24	25.5	29	32.5	43.5	53
Ny	9	9	10	12	14	19	20
P	3	3	3	3	3	5	5
Q	9	11	11	14	14	17.5	20
R	5.5	6.8	6.8	9	9	11	14
S	24	24	24	25	28	33	33
T	16	17	20	21.5	26	34	37.5
U	14	16	18	22	25	35.5	45
V	19	22	25	30	34	46	55
W	25.5	28	32.5	36.5	43	57	65
X	9.5	11	12.5	15	17	23	27.5
Y	12.5	14	16	19.5	22	31	39.5
AA	3 <sup>+0.014</sup>	4 <sup>+0.018</sup>	4 <sup>+0.018</sup>	4 <sup>+0.018</sup>	4 <sup>+0.018</sup>	6 <sup>+0.018</sup>	8 <sup>+0.018</sup>
AB	4	4	5	7	8.5	11.75	14.5
AC	3.5	4.5	4.5	4.5	5	6.5	9
CA	M5X0.8	M6	M6	M8	M8	M10	M12
JA	4	4	4	4	4	4.5	4.5
JB	14	14	14	14	14	19	19
倒角 Chamfer	3	4	4	4	4	6	6
G 螺纹 G Thread	G1/8	G1/8	G1/8	G1/8	G1/8	G1/4	G1/4
O型密封 (-C型) O-ring(Option-C)	1BP5	1BP5	1BP5	1BP5	1BP5	1BP7	1BP7
压板定向销 (附带) (Lever Phasing Pin (Included))	Ø3x6	Ø4x8	Ø4x8	Ø4x8	Ø4x8	Ø6x12	Ø8x16

## 能力曲线图

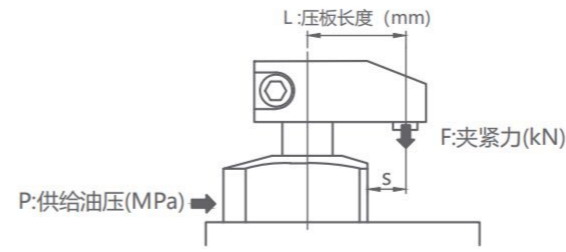

※ CTLA 双压臂型时不符合本图的能力曲线，请通过规格的计算公式另行计。

(例) 使用CTLA-1602□□时  
供给油压为25MPa,压板长度L=50mm时, 夹紧力约为8.9kN。

CTLA-0402□□ CTLB-0402□□		夹紧力计算公式*(kN) F=P/(10.94+0.036×L)								
供给油压 (MPa)	夹紧器输出 (kN)	压板长度L(mm)								最大压板长度 (L) (mm)
		L=35	L=40	L=50	L=60	L=70	L=80	L=90	L=100	
35	3.52	2.9	2.9	2.6						48
32.5	3.27	2.7	2.7	2.6						52
30	3.02	2.5	2.5	2.4						57
27.5	2.77	2.3	2.3	2.2						63
25	2.52	2.1	2.1	2.0	2.0	1.9				71
22.5	2.27	1.9	1.9	1.8	1.8	1.7				81
20	2.01	1.7	1.7	1.6	1.6	1.5	1.5			95
17.5	1.76	1.5	1.5	1.4	1.4	1.4	1.3	1.3	1.2	110
15	1.51	1.3	1.3	1.2	1.2	1.2	1.1	1.1	1.1	130
12.5	1.26	1.1	1.1	1.0	1.0	1.0	1.0	0.9	0.9	140
10	1.01	0.9	0.9	0.8	0.8	0.8	0.8	0.8	0.7	140
7	0.71	0.6	0.6	0.6	0.6	0.6	0.6	0.5	0.5	140
最高使用压力 (MPa)	35	35	33.6	28.8	25.4	22.8	20.8			17.9

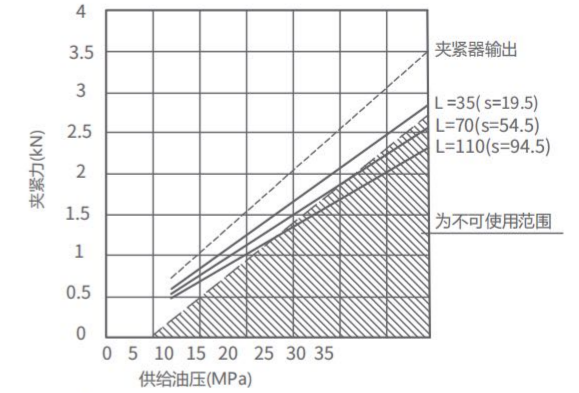

CTLA-0602□□ CTLB-0602□□		夹紧力计算公式*(kN) F=P/(7.57+0.024×L)								
供给油压 (MPa)	夹紧器输出 (kN)	压板长度L(mm)								最大压板长度 (L) (mm)
		L=40	L=50	L=60	L=70	L=80	L=90	L=100	L=120	
35	5.09	4.2	3.8	3.5						49
32.5	4.73	3.9	3.8							54
30	4.36	3.6	3.5							59
27.5	4.00	3.3	3.2	3.1						66
25	3.64	3.0	2.9	2.8	2.8					74
22.5	3.27	2.7	2.6	2.5	2.5	2.4				84
20	2.91	2.4	2.3	2.3	2.2	2.1				98
17.5	2.55	2.1	2.0	2.0	1.9	1.9	1.8			117
15	2.18	1.8	1.8	1.7	1.7	1.6	1.6	1.5		135
12.5	1.82	1.5	1.5	1.4	1.4	1.4	1.3	1.3	1.2	170
10	1.46	1.2	1.2	1.2	1.1	1.1	1.1	1.1	1.0	180
7	1.02	0.9	0.8	0.8	0.8	0.8	0.8	0.8	0.7	180
最高使用压力 (MPa)	35	34.6	29.6	26.0	23.4	21.3	19.6			17.2

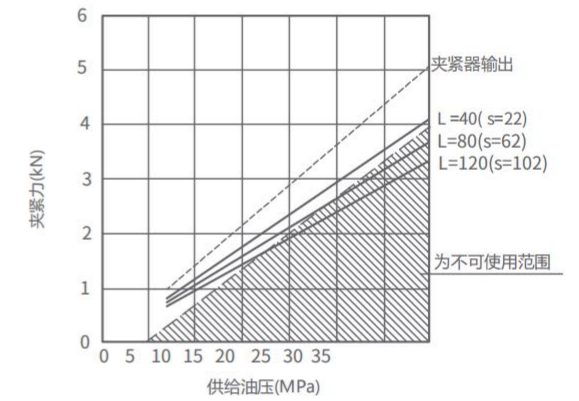

CTLA-0802□□ CTLB-0802□□		夹紧力计算公式*(kN) F=P/(5.53+0.0147×L)								
供给油压 (MPa)	夹紧器输出 (kN)	压板长度L(mm)								最大压板长度 (L) (mm)
		L=40	L=50	L=60	L=70	L=80	L=90	L=100	L=120	
35	6.93	5.8	5.6							50
32.5	6.44	5.4	5.2							55
30	5.94	5.0	4.8	4.7						60
27.5	5.45	4.5	4.4	4.3						66
25	4.95	4.1	4.0	3.9	3.9					74
22.5	4.46	3.7	3.6	3.6	3.5	3.4				84
20	3.96	3.3	3.2	3.2	3.1	3.0	3.0			98
17.5	3.47	2.9	2.8	2.8	2.7	2.7	2.6	2.5		116
15	2.97	2.5	2.4	2.4	2.3	2.3	2.2	2.2	2.1	135
12.5	2.48	2.1	2.0	2.0	2.0	1.9	1.9	1.8	1.8	170
10	1.98	1.7	1.6	1.6	1.6	1.5	1.5	1.5	1.4	210
7	1.39	1.2	1.2	1.2	1.1	1.1	1.1	1.1	1.0	210
最高使用压力 (MPa)	35	35	30.0	26.3	23.5	21.4	19.6			17.1

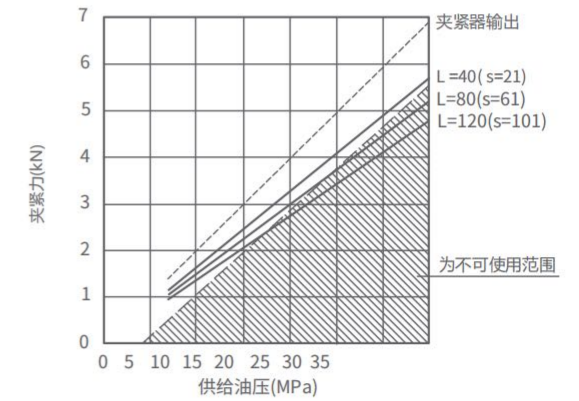

CTLA-1002□□ CTLB-1002□□		夹紧力计算公式*(kN) F=P/(3.91+0.049×L)								
供给油压 (MPa)	夹紧器输出 (kN)	压板长度L(mm)								最大压板长度 (L) (mm)
		L=45	L=50	L=60	L=70	L=90	L=110	L=130	L=150	
35	9.82	8.1	8.0	7.9						66
32.5	9.12	7.6	7.5	7.3	7.2					72
30	8.42	7.0	6.9	6.8	6.6					80
27.5	7.72	6.4	6.3	6.2	6.1					88
25	7.01	5.8	5.8	5.6	5.5	5.3				99
22.5	6.31	5.2	5.2	5.1	5.0	4.8	4.6			113
20	5.61	4.7	4.6	4.5	4.4	4.3	4.1	3.9		132
17.5	4.91	4.1	4.0	4.0	3.9	3.7	3.6	3.5	3.3	145
15	4.21	3.5	3.5	3.4	3.3	3.2	3.1	3.0	2.9	175
12.5	3.51	2.9	2.9	2.8	2.8	2.7	2.6	2.5	2.4	230
10	2.81	2.4	2.3	2.3	2.2	2.2	2.1	2.0	1.9	230
7	1.97	1.7	1.6	1.6	1.6	1.5	1.5	1.4	1.4	230
最高使用压力 (MPa)	35	35	35	33.4	27.1	23.0	20.2			18.2

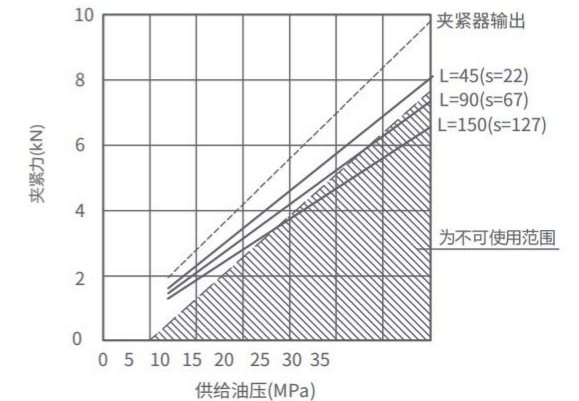

### 注意事项

1. 本表表示夹紧力(kN)与供给油压(MPa)之间的关系。
2. 夹紧器推力(L=0时)不能根据各规格栏的计算公式求取。
3. 有时会因供给油压以及压板的安装姿势等因素, 导致惯性矩较大的压板无法实施旋转动作。
4. 夹紧力表示压板在水平位置夹紧时的夹紧能力。
5. 夹紧力随压板长度变化而变化。请在适合压板长度的供给油压条件下使用。
6. 若在上表所规定的不可使用范围内使用, 就会导致变形、卡滞、漏油等事故。
7. 本图表中的数据是参考值, 详细数据请根据各夹紧力计算公式求取。

※在夹紧力计算公式中, F: 夹紧力 (kN)、P: 供给油压(MPa)、L: 压板长度 (mm)。

CTLA-1602□□ CTLB-1602□□		夹紧力计算公式※(kN) $F=P/(2.59+0.0046 \times L)$								最大压板长度 (L) (mm)
供给油压 (MPa)	夹紧器输出 (kN)	压板长度L(mm)								
		L=50	L=60	L=70	L=80	L=90	L=100	L=120	L=150	
35	14.60	12.5	12.3							62
32.5	13.56	11.6	11.4							67
30	12.51	10.7	10.5	10.4						73
27.5	11.47	9.8	9.6	9.5	9.3					81
25	10.43	8.9	8.8	8.6	8.5	8.4				90
22.5	9.39	8.0	7.9	7.8	7.7	7.5	7.4			102
20	8.34	7.1	7.0	6.9	6.8	6.7	6.6			118
17.5	7.30	6.3	6.2	6.1	6.0	5.9	5.8	5.6		139
15	6.26	5.4	5.3	5.2	5.1	5.0	5.0	4.8	4.6	150
12.5	5.22	4.5	4.4	4.3	4.3	4.2	4.1	4.0	3.9	195
10	4.17	3.6	3.5	3.5	3.4	3.4	3.3	3.2	3.1	230
7	2.92	2.5	2.5	2.5	2.4	2.4	2.3	2.3	2.2	230
最高使用压力 (MPa)		35	35	31.3	27.8	25.1	22.9	19.7	16.4	

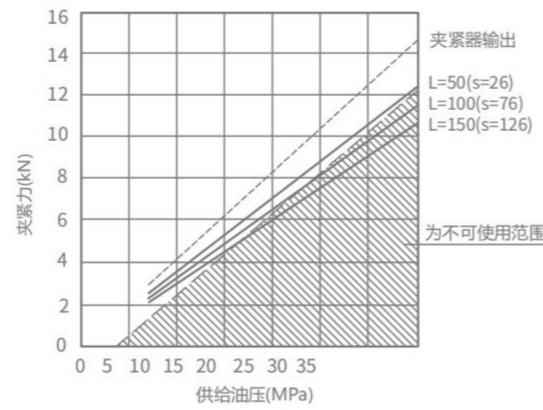

CTLA-2502□□ CTLB-2502□□		夹紧力计算公式※(kN) $F=P/(1.32+0.0018 \times L)$								最大压板长度 (L) (mm)
供给油压 (MPa)	夹紧器输出 (kN)	压板长度L(mm)								
		L=70	L=80	L=90	L=100	L=120	L=140	L=160	L=200	
35	28.70	24.3	24.0	23.7						91
32.5	26.65	22.5	22.2	22.0						99
30	24.60	20.8	20.5	20.3	20.0					109
27.5	22.55	19.1	18.8	18.6	18.4	18.0				120
25	20.50	17.3	17.1	16.9	16.7	16.3				134
22.5	18.45	15.6	15.4	15.2	15.0	14.7	14.4			153
20	16.40	13.9	13.7	13.5	13.4	13.1	12.8	12.5		176
17.5	14.35	12.2	12.0	11.9	11.7	11.4	11.2	10.9	10.5	208
15	12.30	10.4	10.3	10.2	10.0	9.8	9.6	9.4	9.0	240
12.5	10.25	8.7	8.6	8.5	8.4	8.2	8.0	7.8	7.5	280
10	8.20	7.0	6.9	6.8	6.7	6.6	6.4	6.3	6.0	280
7	5.74	4.9	4.8	4.8	4.7	4.6	4.5	4.4	4.2	280
最高使用压力 (MPa)		35	35	35	32.3	27.5	24.2	21.6	18.1	

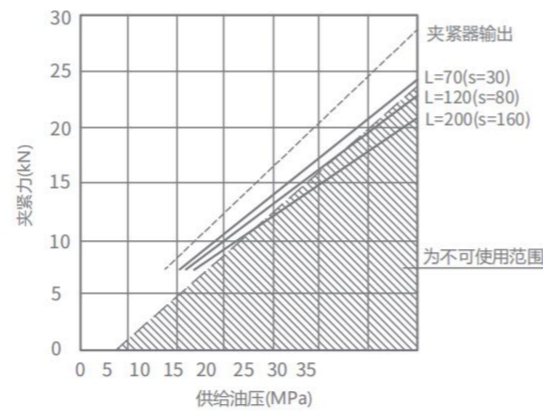

CTLA-4002□□ CTLB-4002□□		夹紧力计算公式※(kN) $F=P/(0.87+0.0011 \times L)$								最大压板长度 (L) (mm)
供给油压 (MPa)	夹紧器输出 (kN)	压板长度L(mm)								
		L=85	L=100	L=125	L=150	L=175	L=200	L=225	L=250	
35	43.30	36.4	35.8	34.8						126
32.5	40.21	33.8	33.2	32.3						138
30	37.11	31.2	30.7	29.8	29.0					151
27.5	34.02	28.6	28.1	27.3	26.6					168
25	30.93	26.0	25.6	24.9	24.2	23.6				189
22.5	27.84	23.4	23.0	22.4	21.8	21.2	20.7			216
20	24.74	20.8	20.5	19.9	19.4	18.9	18.4	17.9	17.5	251
17.5	21.65	18.2	17.9	17.4	17.0	16.5	16.1	15.7	15.3	290
15	18.56	15.6	15.4	14.9	14.5	14.2	13.8	13.5	13.2	330
12.5	15.47	13.0	12.8	12.5	12.1	11.8	11.5	11.2	11.0	330
10	12.37	10.4	10.3	10.0	9.7	9.5	9.2	9.0	8.8	330
7	8.66	7.3	7.2	7.0	6.8	6.6	6.5	6.3	6.2	330
最高使用压力 (MPa)		35	35	35	30.2	26.6	23.9	21.8	20.1	

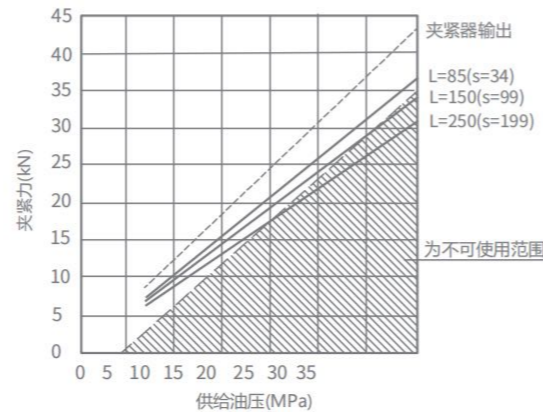

### 附件: 毛坯旋转压板

※设计加工压板时安装部位尺寸切勿超出下表所规定的范围。如果制作压板时超出下表所规定的尺寸范围, 会导致夹紧力达不到规定值, 以及变形、卡滞、动作不良等故障。

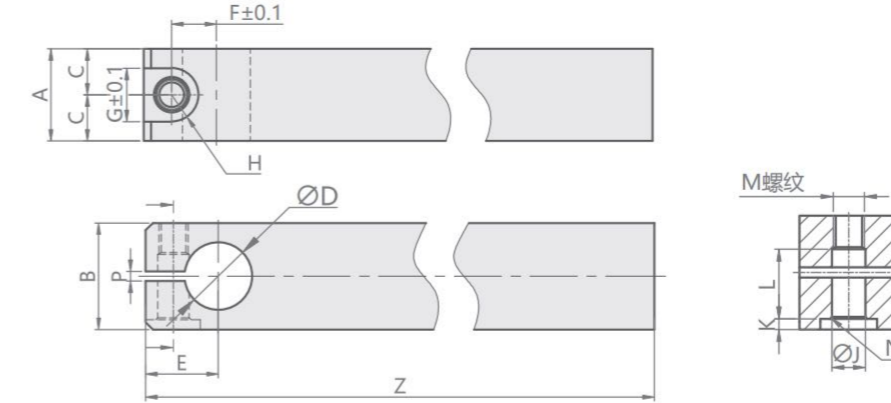

Unit:mm

型号	CTLA-0402□□	CTLA-0602□□	CTLA-0802□□	CTLA-1002□□	CTLA-1602□□	CTLA-2502□□	CTLA-4002□□
	CTLB-0402□□	CTLB-0602□□	CTLB-0802□□	CTLB-1002□□	CTLB-1602□□	CTLB-2502□□	CTLB-4002□□
A	19	22	25	30	34	46	55
B	22	25	26	32	36	53	70
C	9.5	11	12.5	15	17	23	27.5
D	14 <sup>+0.016</sup>	16 <sup>+0.016</sup>	18 <sup>+0.016</sup>	22 <sup>+0.02</sup>	25 <sup>+0.02</sup>	35.5 <sup>+0.025</sup>	45 <sup>+0.025</sup>
E	15	18	19	23	26.5	36.5	46
F	9.25	11	12	14.75	17	23.5	29.75
G	11	14	14	17.5	20	26	32
H	5.5	7	7	8.75	10	13	16
J	6.5	8.5	8.5	10.5	12.5	16.5	21
K	2	3	3	4	4	7	9
L	13.5	15.5	16	18	22	31	42
M	M6	M8x1	M8x1	M10x1.25	M12x1.5	M16x1.5	M20x2
N	C0.4	C0.6	C0.6	C0.6	C1	C1	C1
P	2	2	2	2	2	2	2
Z	105	120	145	160	170	185	220

### 注意事项

1. 需要进行压板的相位调整时, 请参考(相位确定用销孔补充加工尺寸)进行补充加工,
2. 压板连接螺栓由用户另行购买。

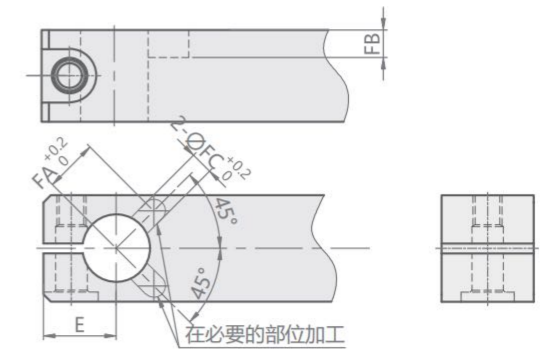

Unit:mm

### 压板定位专用销孔 补充加工尺寸(参考)

型号	CTLA-0402□□	CTLA-0602□□	CTLA-0802□□	CTLA-1002□□	CTLA-1602□□	CTLA-2502□□	CTLA-4002□□
	CTLB-0402□□	CTLB-0602□□	CTLB-0802□□	CTLB-1002□□	CTLB-1602□□	CTLB-2502□□	CTLB-4002□□
E	15	18	19	23	26.5	36.5	46
FA	10.5	12.5	13.5	15.5	17	24.2	31
FB	5.5	7	7	7	7.5	10	13.5
FC	3	4	4	4	4	6	8

### 注意事项

1. 加工相位确定用销孔时, 请参考本图并根据其用途在必要的部位进行加工。

# NFS

## 高压转角缸

### NFS HIGH PRESSURE HYDRAULIC SWING CLAMP



#### 产品特性

向左或向右旋转后垂直下压达到夹持目的。标准角度90度,可订做角度30度45度、60度。缸体为高级碳钢材表面硬化处理。入油口请加装流量控制阀,控制转角速度,避免惯性冲击。

下压夹持时,应于垂直行程内夹紧工件。每次上下工作时,务必以气枪清洁活塞杆处油封上的铁屑异物,避免下次使用异物嵌入工件。

最大操作压力: 210 kgf/cm<sup>2</sup>

最小操作压力: 70 kgf/cm<sup>2</sup>

作动方式: 单动和复动式

#### FEATURES

A hydraulic swing clamp is a clamping device that converts hydraulic pressure into a clamping force to secure the pieces. When the NFS hydraulic swing-clamp is in action, it clamps down vertically after rotating to the left or right.

The cylinder's body is manufactured with high grade carbon steel and processed with hardened-surface treatment.

The standard angle is 90 degrees, options to customize the angle at 30 degrees, 45 degrees, or 60 degrees are available. Installation of a flow control valve at the oil inlet is highly recommended to control the swinging speed and avoid inertial impact. When the hydraulic cylinder is clamping and pressing downward, the workpiece should be clamped within the lock stroke range.

During the workpiece's loading & unloading period, please be sure to clean the oil seal from the piston rod with an air gun to avoid embedding any particles and chips.

Max.operating pressure:210 kgf/cm<sup>2</sup>

Min.operating pressure:70 kgf/cm<sup>2</sup>

Single acting and double acting

#### 剖面图 Sectional view(复动式)

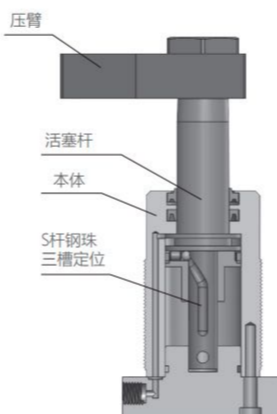

#### 注意事项

夹紧及放松作动速度需适当放缓。特殊压臂其长度和重量不得超过标准压臂的1.5倍。

压臂旋转示意图及安装拆卸方式, 请参见第4页。可接受订制, 欢迎与本公司洽询。

#### NOTE

The action and the speed of clamping / unclamping needs to be slowed down appropriately.

The length and weight of the customized clamping arm shall not exceed 1.5 times of the standard clamping arm.

Please refer to page 4 for the rotation diagram, installation instructions and removal methods of the clamping arm.

Customization is available upon request, please contact us for more info.

#### 订购标示法 ORDERING INDICATION

示例: NFSL-25A-90F

<b>NFS</b>	系列 Series	NFS/NDS/NFT/NDT
<b>L</b>	转角方向 Swing direction	右转R或左转L Turn right R or turn left L
<b>25</b>	油缸内径 Hydraulic cylinder inside diameter	Φ25, Φ32, Φ40
<b>A</b>	作动方式 Acting type	<div style="display: flex; justify-content: space-around;"> <div style="text-align: center;"> <p>A:单动式 Single acting</p> <p>LINE TYPE 配管式 F:MANIFOLD TYPE F:油路板型 TB:THREADED BODY TB:外螺牙配管型</p> </div> <div style="text-align: center;"> <p>B:复动式 Double acting</p> <p>LINE TYPE 配管式 F:MANIFOLD TYPE F:油路板型 TB:THREADED BODY TB:外螺牙配管型</p> </div> </div>
<b>90</b>	转角角度 Swing angle	标准角度 Standard angle 90°(±2°) 订做角度 Order angle 30°±2°, 45°±2°, 60°±2°
<b>F</b>	安装型式 Mounting type	空白: 配管型 Line type F: 油路板型 Manifold type (外螺牙无油路板型)

#### 规格参数表 SPECIFICATIONS

型号	理论夹持力 (210 kgf/cm <sup>2</sup> )	转角行程	夹紧行程	总行程	拉入容积	推出容积	拉入受压面积	推出受压面积	使用温度范围
MODEL	CLAMPING FORCE AT 210kgf/cm <sup>2</sup> (kgf)	SWING STROKE (mm)	CLAMPING STROKE (mm)	TOTAL STROKE(mm)	CYLINDER CAPACITY CLAMP(cm <sup>3</sup> )	CYLINDER CAPACITY UNCLAMP(cm <sup>3</sup> )	EFF.PISTON AREA CLAMP(cm <sup>2</sup> )	EFF.PISTON AREA UNCLAMP(cm <sup>2</sup> )	RANGE OF TEMPERATURE(°C)
NFS-25A NDS-25A NFT-25A NDT-25A	420	12	11	23	5.45	-	2.37	-	-10~+70°C
NFS-32A NDS-32A NFT-32A NDT-32A	760	12	11	23	9.75	-	4.24	-	-10~+70°C
NFS-40A NDS-40A NFT-40A NDT-40A	1450	12	11	23	17.60	-	7.65	-	-10~+70°C
NFS-25B NDS-25B NFT-25B NDT-25B	495	15	18	33	7.82	16.20	2.37	4.91	-10~+70°C
NFS-32B NDS-32B NFT-32B NDT-32B	890	15	18	33	13.99	26.53	4.24	8.04	-10~+70°C
NFS-40B NDS-40B NFT-40B NDT-40B	1600	15	18	33	25.25	41.25	7.65	12.5	-10~+70°C

**NFS**

Single side swing clamp

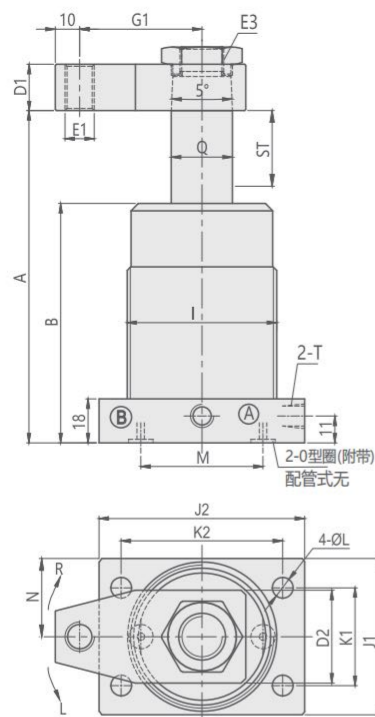

Ⓐ 夹持油孔 Clamping port    Ⓑ 放松油孔 Unclamping port(单动型为排气孔)

**NDS**

Double side swing clamp

注:下图为转角90°松开状态

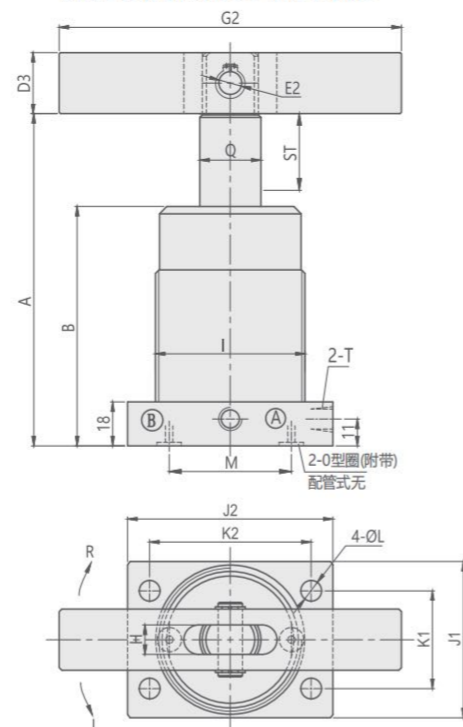
**NFT**

Single side swing clamp

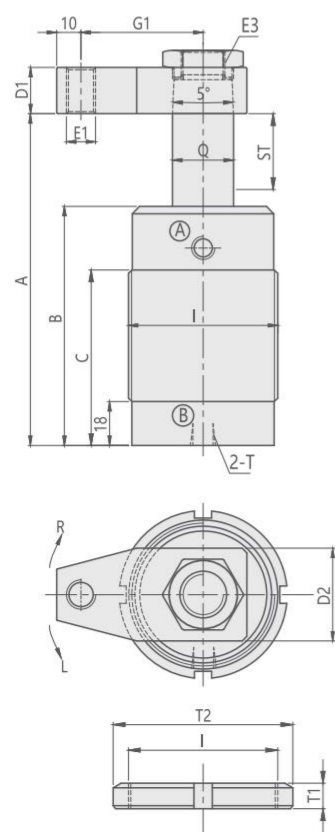
**NDT**

Double side swing clamp

注:下图为转角90°松开状态

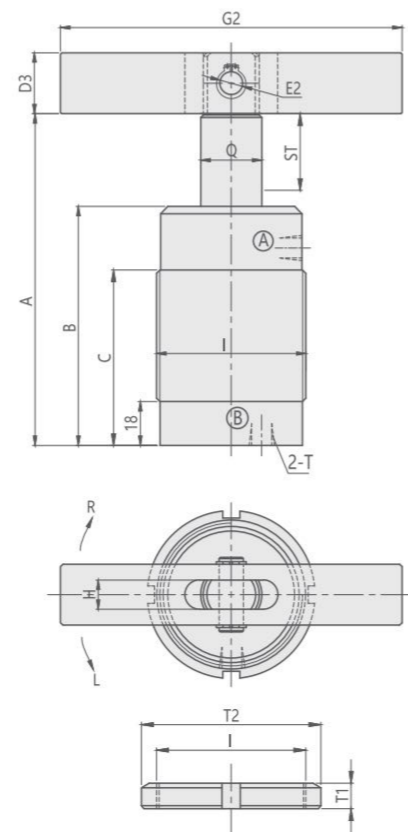

四方底座型 Flange type	NFS-25A NDS-25A	NFS-32A NDS-32A	NFS-40A NDS-40A	NFS-25B NDS-25B	NFS-32B NDS-32B	NFS-40B NDS-40B
外螺外牙型 Threaded type	NFT-25A NDT-25A	NFT-32A NDT-32A	NFT-40A NDT-40A	NFT-25B NDT-25B	NFT-32B NDT-32B	NFT-40B NDT-40B
ST:Swing/ Clamping	23:12/11	23:12/11	23:12/11	33:15/18	33:15/18	33:15/18
A松开状态 Unclamping	131	127	127	136	136	136
B	102	97	98	102	97	98
C	66	70	72	66	70	72
D1	19	19	19	19	19	19
D2	38	38	38	38	38	38
D3	□19	□22	□25	□19	□22	□25
E1	M12	M12	M12	M12	M12	M12
E2	Φ8	Φ8	Φ10	Φ8	Φ8	Φ10
E3	M14x1	M18x1.5	M18x1.5	M14x1	M18x1.5	M18x1.5
G1	45	50	50	45	50	50
G2	100	120	140	100	120	140
H	9	10	12	9	10	12
I	M45x1.5	M50x1.5	M60x1.5	M45x1.5	M50x1.5	M60x1.5
J1	46	54	64	46	54	64
J2	64	68	84	64	68	84
K1	30	34	40	30	34	40
K2	50	54	66	50	54	66
L	Φ6.5	Φ8.5	Φ8.5	Φ6.5	Φ8.5	Φ8.5
M	35	40	50	35	40	50
N	23	27	32	23	27	32
T	PT1/8	PT1/8	PT1/8	PT1/8	PT1/8	PT1/8
T1(2pcs)	10	11	11	10	11	11
T2	Φ65	Φ70	Φ80	Φ65	Φ70	Φ80
Q	Φ18	Φ22	Φ25	Φ18	Φ22	Φ25
O型圈(仅F型) O-Ring(F type)	P7	P7	P7	P7	P7	P7

# 030

## 底部法兰油压转角缸

### 030 HYDRAULIC SWING CLAMP



#### 产品特性

无需预留孔:直接用螺栓将转角缸固定到工作台面,缸体的主结构在工作台面上,可夹紧较厚的工件,允许超大件的夹持。  
 复动式特点:夹紧与松卸全靠油路来控制,按照换向阀的方向交替来控制转角缸的夹紧和松卸行程,压臂形状与单动缸相同。  
 单动式特点:内部系统化比较简单,没有卸载系统,卸载时靠弹簧回力完成松卸行程,外部管路的阀门及附件较少,使配套系统比较简单。创新的压臂设计能满足多种场合。  
 缸体材质合用碳钢,经渗碳氮化处理,表面硬度高,缸体内面硬度高耐磨损。

最大操作压力: 250 kgf/cm<sup>2</sup>  
 最小操作压力: 70 kgf/cm<sup>2</sup>  
 作动方式: 单动和复动式

#### FEATURES

It is not necessary to manufacture a hole for the installing and you just need to use bolt to fix the swing clamp on the fixture plate. It is helpful for you to clamp thick workpiece because the main structure of the cylinder body is on the fixture plate.  
 Feature of the doubling acting type: Oil circuits control clamping and unclamping, you can control the clamping and unclamping by changing the direction valve.  
 Feature of the single acting type: The design of the interior system is simple. It is not necessary to design for unclamping. It can return back to the original position by spring and the system design is simple because of few accessories.  
 The material of the cylinder body is carbon steel and treated by nitriding. The hardness of the outside and inside surface of the cylinder is high and the cylinder is anti-abrasive.

Max. operating pressure: 250 kgf/cm<sup>2</sup>  
 Min. operating pressure: 70 kgf/cm<sup>2</sup>  
 Single acting and double acting

剖面图 Sectional view (单动式)

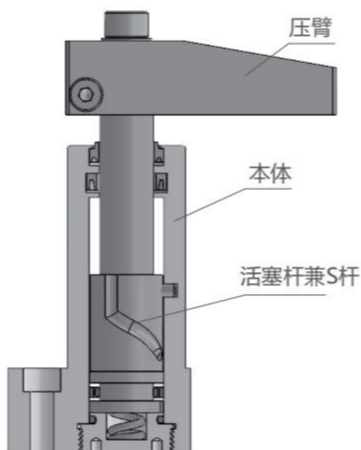

#### 注意事项

夹紧及放松作动速度需适当放缓。  
 特殊压臂长度及重量不得超过标准压臂的1.5倍。  
 压臂旋转示意图及安装拆卸方式,请参见第4页。

#### NOTE

The action and the speed of clamping / unclamping needs to be slowed down appropriately.  
 The length and weight of the customized clamping arm shall not exceed times of the standard clamping arm.  
 Please refer to page 4 for the rotation diagram, installation instructions and removal methods of the clamping arm.

#### 订购标示法 ORDERING INDICATION

示例: 030-LD92-90

<b>030</b>	系列 Series	030	
<b>L</b>	转角方向 Swing direction	右转R或左转L	Turn right R or turn left L
<b>D</b>	作动方式 Acting type	S:单动式 D:复动式	S:Single acting D:Double acting
<b>92</b>	型号 Type	22, 52, 92, 121, 202	
<b>90</b>	转角角度 Swing angle	标准角度 订做角度	Standard angle 90°(±2°) Order angle 30°(±2°), 45°(±2°), 60°(±2°)

030-22/52/121

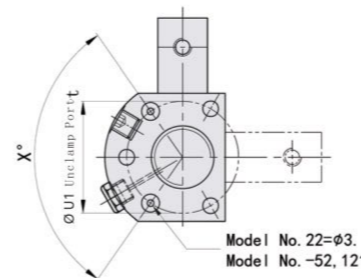

030-92/202

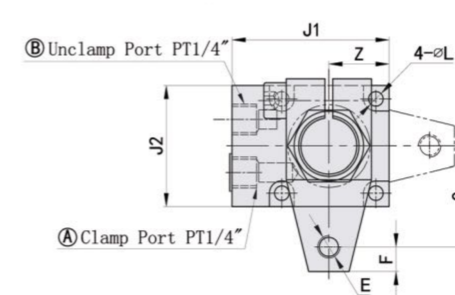
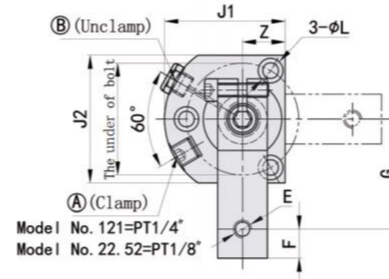
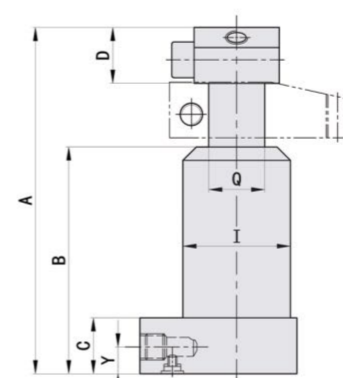
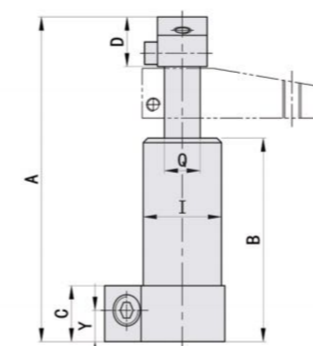
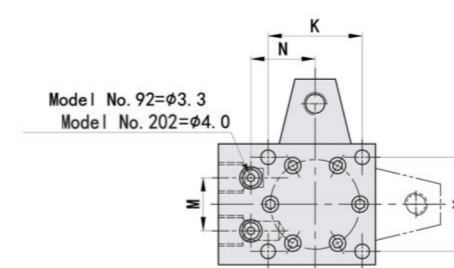

MODEL ITEM	030-22	030-52	030-92	030-121	030-202
ST:Swing /Clamp	16.5:8.5 /8	22.6:12.6 /10	22.1:10.1 /12	28.4:15.4 /13	27.9:13.9 /14
A松开状态 Unclamping	118	145.2	155	171	175
B	78	91	101.5	110.9	110
C	25	25	25	25	25
D	16	22	25	30	32
E	M6	M8	M10	M10	M12
F	6	13	11	12	15
G	40	49	45	51	55
I	Φ28	Φ35	Φ48	Φ48	Φ63
J1	47.2	54.1	70.1	66.8	85.1
J2	45	57	54	73	70
K	-	-	42	-	55
L	Φ5.5-Φ9 x6.5D	Φ7-Φ11 x7D	Φ6.8-Φ11 x7D	Φ8.5-Φ14 x9D	Φ8.5-Φ14 x9D
M	-	-	23.6	32	29
N	-	-	28.7	-	35.1
Z	15.5	19.1	26.9	25.4	35.1
U1	Φ40	Φ50	-	Φ64	-
X	60°	110°	-	110°	-
Y	14	14	12	16	12
Q	Φ10	Φ16	Φ25	Φ22	Φ32

#### 规格参数表 SPECIFICATIONS

型号	理论夹持力(250 kgf/cm <sup>2</sup> ) CLAMPING FORCE AT 250kgf/cm <sup>2</sup> (kgf)		转角行程	夹紧行程	总行程	拉入容积	推出容积	拉入受压面积	推出受压面积	使用温度范围
MODEL	单动系列 Single acting	复动系列 Double acting	SWING STROKE (mm)	CLAMPING STROKE (mm)	TOTAL STROKE(mm)	CYLINDER CAPACITY CLAMP(cm <sup>3</sup> )	CYLINDER CAPACITY UNCLAMP(cm <sup>3</sup> )	EFFPISTON AREA CLAMP(cm <sup>2</sup> )	EFFPISTON AREA UNCLAMP(cm <sup>2</sup> )	RANGE OF TEMPERATURE(°C)
030-22	173	180	8.5	8	16.5	1.24	2.52	0.75	1.53	-10~+70°C
030-52	380	445	12.6	10	22.6	4.05	8.57	1.79	3.79	-10~+70°C
030-92	710	780	10.1	12	22.1	6.92	17.75	3.13	8.03	-10~+70°C
030-121	970	1060	15.4	13	28.4	12.04	22.81	4.24	8.03	-10~+70°C
030-202	1830	1960	13.9	14	27.9	21.93	44.33	7.86	15.89	-10~+70°C

# 050

## 顶部法兰油压转角缸

## 050 HYDRAULIC SWING CLAMP



### 产品特性

当空间非常小时, 050系列具备最小的安装高度;但需预留孔放置转角缸;缸体的主结构可隐藏在工作台面;安装简单, 只用三四个螺栓就能固定;对称法兰设计使转角缸采用三点或四点螺栓对称固定。

050分为单动式和复动式两种。

复动式特点:夹紧与松卸完全靠油路控制, 按照换向阀的方向交替来控制转角缸的夹紧与松卸过程。

单动式特点:内部系统化比较简单, 没有卸载系统, 卸载时靠弹簧回力完成松卸行程外部管路的阀门及附件较少,使配套系统比较简单。单动式可以空载回程。缸体材质合用碳钢, 经渗碳氮化处理, 表面硬度高缸体内面硬度高而耐磨。

最大操作压力: 250kgf/cm<sup>2</sup>

最小操作压力: 70kgf/cm<sup>2</sup>

作动方式: 单动和复动式

### FEATURES

050 series owns the smallest height for mounting when space is limited, but it is necessary to manufacture a hole for installing swing clamp on fixture plate and the cylinder body can be inserted into the fixture plate. Installing is very simple. You just need 3 or 4 PCS of bolts to fix your swing clamp cylinder. It has the single acting and double acting type. Feature of the doubling acting type: Oil circuits control clamping and unclamping, you can control the clamping and unclamping by changing the direction of the valve. Feature of the single acting type: The design of the interior system is simple. It is not necessary to design for unclamping. It can return back to original position by spring and the system design is simple because of few accessories. It can return back to position under free load. The material of the cylinder body is carbon steel and treated by nitriding. The hardness of the outside and inside surface of the cylinder is high and the cylinder is anti-abrasive.

Max. operating pressure: 250kgf/cm<sup>2</sup>

Min. operating pressure: 70kgf/cm<sup>2</sup>

Single acting and double acting

### 剖面图Sectional view (复动型)

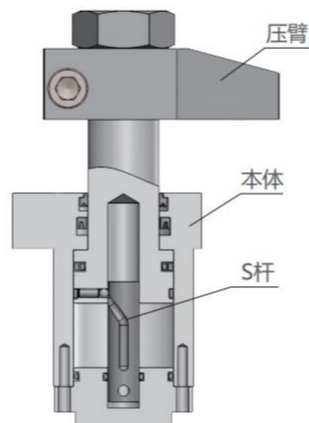

050-22/52/121

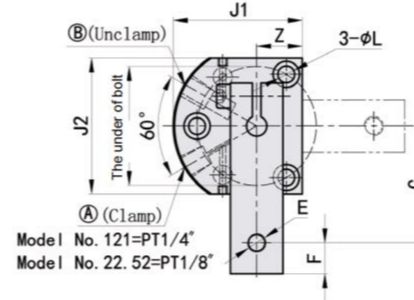
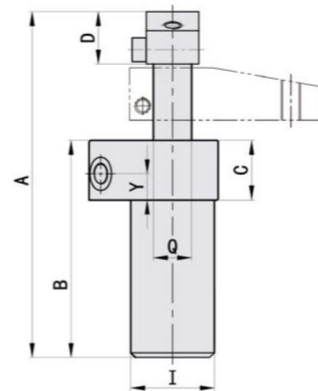
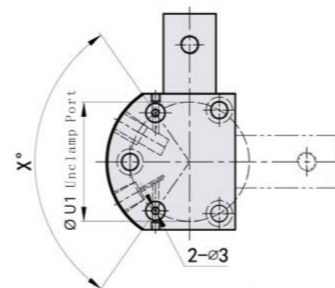

050-92/202

Model No. 92=Ø3.3  
Model No. 202=Ø4.0

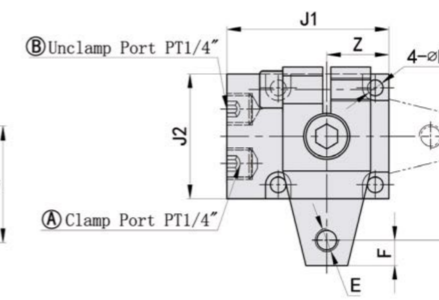
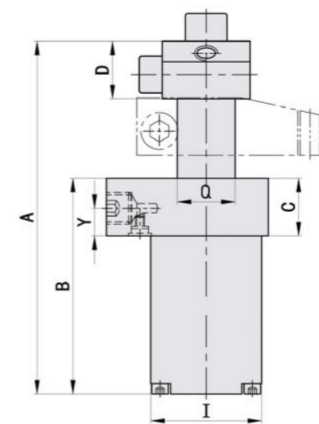
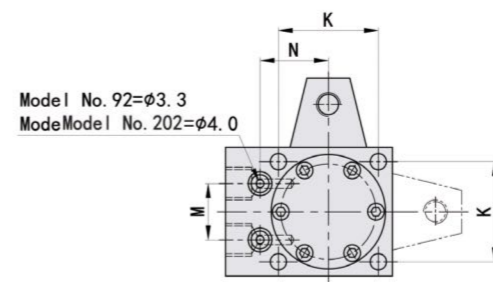

MODEL ITEM	050-22	050-52	050-92	050-121	050-202
ST:Swing /Clamp	165:8.5 /8	226:12.6 /10	221:10.1 /12	284:15.4 /13	279:13.9 /14
A:松开状态 Undamping	118	145	153	171.5	169
B	78	91	93.5	110.9	104
C	25	25	25	25	25
D	16	22	25	30	32
E	M6	M8	M10	M10	M12
F	6	13	11	12	15
G	40	49	45	51	55
I	Ø28	Ø35	Ø48	Ø48	Ø63
J1	47.2	54.1	70.1	66.8	85.1
J2	45	57	54	73	70
K	-	-	42	-	55
L	Ø5.5-Ø9 x6.5D	Ø7-Ø11 x7D	Ø6.8-Ø11 x7D	Ø8.5-Ø14 x9D	Ø8.5-Ø14 x9D
M	-	-	23.6	32	29.2
N	-	-	28.7	-	35.6
Z	15.5	19.1	26.9	25.4	35.1
U1	Ø40	Ø50	-	Ø64	-
X	60°	110°	-	110°	-
Y	11	11	12	12	13
Q	Ø10	Ø16	Ø25	Ø22	Ø32

### 注意事项

夹紧及放松作动速度需适当放缓。特殊压臂长度及重量不得超过标准压臂的1.5倍。压臂旋转示意图及安装拆卸方式, 请参见第4页。

### NOTE

The action and the speed of clamping / unclamping needs to be slowed down appropriately. The length and weight of the customized clamping arm shall not exceed 1.5 times of the standard clamping arm. Please refer to page 4 for the rotation diagram, installation instructions and removal methods of the clamping arm.

### 订购标示法 ORDERING INDICATION

示例: 050-LD92-90

050	系列 Series	050
L	转角方向 Swing direction	右转R或左转L Turn right R or turn left L
D	作动方式 Acting type	S:单动式 S:Single acting D:复动式 D:Double acting
92	型号 Type	22, 52, 92, 121, 202
90	转角角度 Swing angle	标准角度 Standard angle 90°(±2°) 订做角度 Order angle 30°(±2°), 45°(±2°), 60°(±2°)

### 规格参数表 SPECIFICATIONS

型号	理论夹持力(250 kgf/cm <sup>2</sup> ) CLAMPING FORCE AT 250 kgf/cm <sup>2</sup> (kgf)	转角行程	夹紧行程	总行程	拉入容积	推出容积	拉入受压面积	推出受压面积	使用温度范围	
MODEL	单动系列 Single acting	复动系列 Double acting	SWING STROKE (mm)	CLAMPING STROKE (mm)	TOTAL STROKE(mm)	CYLINDER CAPACITY CLAMP(cm <sup>3</sup> )	CYLINDER CAPACITY UNCLAMP(cm <sup>3</sup> )	EFF:PISTON AREA CLAMP(cm <sup>2</sup> )	EFF:PISTON AREA UNCLAMP(cm <sup>2</sup> )	RANGE OF TEMPERATURE(°C)
050-22	173	180	8.5	8	16.5	1.24	2.52	0.75	1.53	-10~+70°C
050-52	380	445	14.6	8	22.6	4.05	8.57	1.79	3.79	-10~+70°C
050-92	710	780	14.1	8	22.1	6.92	17.75	3.13	8.03	-10~+70°C
050-121	970	1060	18.4	10	28.4	12.04	22.81	4.24	8.03	-10~+70°C
050-202	1830	1960	17.9	10	27.9	21.93	44.33	7.86	15.89	-10~+70°C

# HPS

## 高压转角缸

# HPS HIGH PRESSURE HYDRAULIC SWING CLAMP

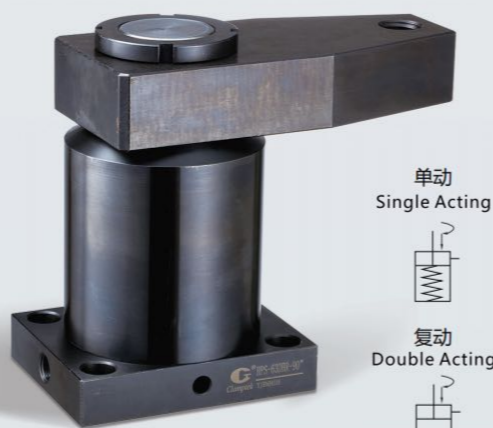

### 产品特性

此型式油压缸适用于夹持工件取放空间保持净空,方便工件取放高压夹持。油压缸夹持动作作为下压式,含有旋转行程(请勿夹持工件)以及垂直下压行程。本产品使用德制油封及进口零件,缸体内壁经特殊加工处理表面光滑确保使用性能及寿命。最大充油速度请参考特性资料,请勿使用过大充油速度,以免回转过快,如有回转过快,请安装流量控制阀,降低充油速度。

最大操作压力: 250 kgf/cm<sup>2</sup>  
 最小操作压力: 70 kgf/cm<sup>2</sup>  
 作动方式: 单动和复动式

### FEATURES

The clamping mechanism of the HPS series includes a swing stroke and a vertical stroke. For operational instructions, do not clamp the workpiece during the rotation. The cylinder uses high-quality oil seals and components imported directly from Germany. The smooth interior wall is processed specifically to enhance product performance and increase product lifespan. Please refer to the specification chart for the maximum fluid supply. Installation of a flow control valve is highly recommended for better control.

Max. operating pressure: 250 kgf/cm<sup>2</sup>  
 Min. operating pressure: 70 kgf/cm<sup>2</sup>  
 Single acting and double acting

### 剖面图 Sectional view

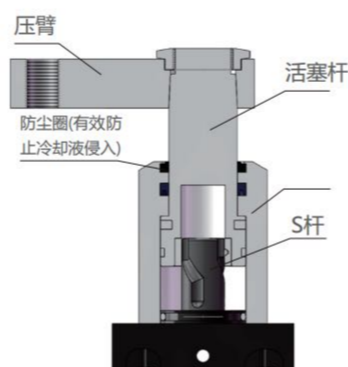

### 注意事项

夹紧及放松作动速度需适当放缓。特殊压臂长度及重量不得超过标准压臂的1.5倍。压臂旋转示意图及安装拆卸方式,请参见第4页。

### NOTE

The action and the speed of clamping / unclamping needs to be slowed down appropriately. The length and weight of the customized clamping arm shall not exceed 1.5 times of the standard clamping arm. Please refer to page 4 for the rotation diagram, installation instructions and removal methods of the clamping arm.

### 订购标示法 ORDERING INDICATION

示例: HPS-25SAR-90

<b>HPS</b>	系列 Series	HPS
<b>25</b>	油缸内径 Hydraulic cylinder inside diameter	Φ25, Φ32, Φ40, Φ50, Φ63
<b>S</b>	作动方式 Acting type	S:单动式 Single acting D:复动式 Double acting
<b>A</b>	安装型式 Installation	A: 全牙型 Threaded type B: 配管型 Line type C: 油路板型 Manifold type
<b>R</b>	转角方向 Swing direction	R: 右转下压型 R: Turn right L: 左转下压型 L: Turn left
<b>90</b>	转角角度 Swing angle	标准角度 Standard angle 90°(±2°) 订做角度 Order angle 30°(±2°), 45°(±2°), 60°(±2°)

### 单动式 Single-Acting

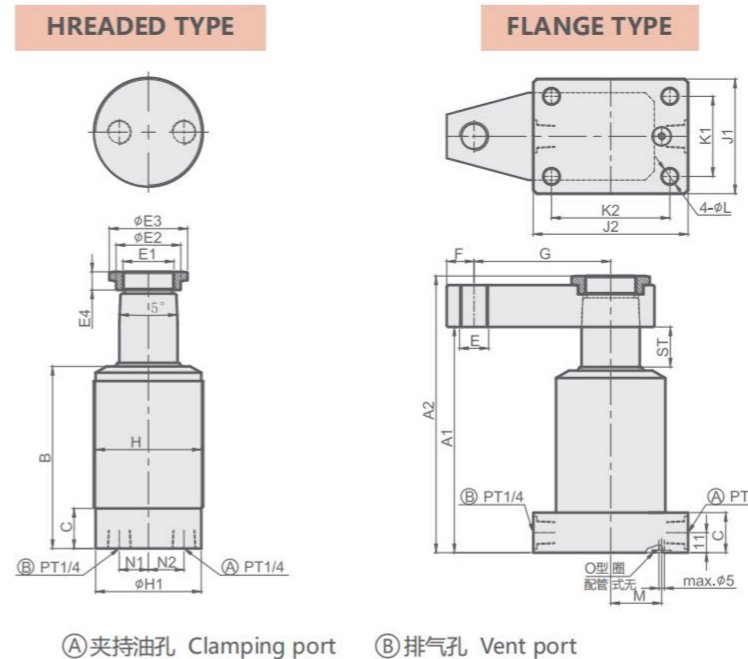

### 复动式 Double-Acting

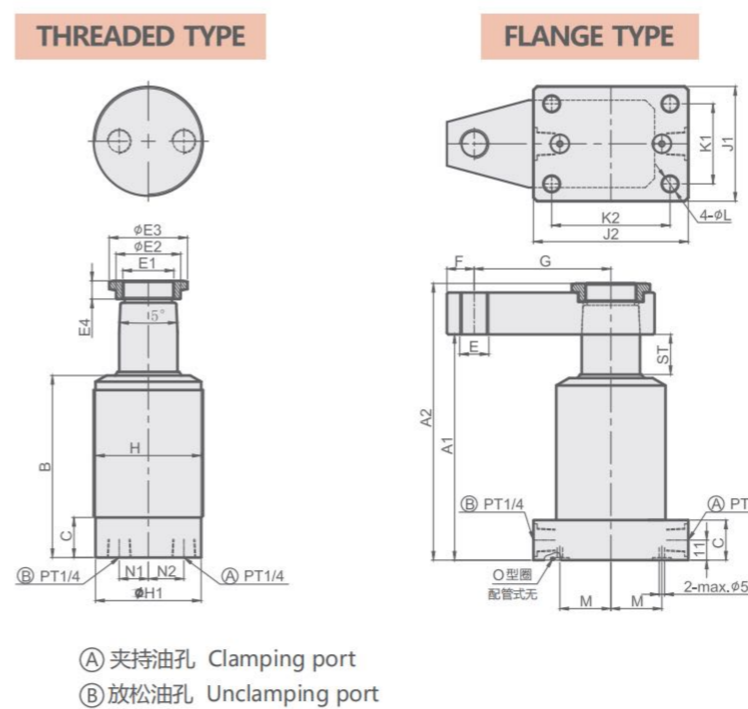

Unit:mm

型号	HPS-25	HPS-32	HPS-40	HPS-50	HPS-63
<b>A1</b> 松开状态	109	120.5	124	142	148
<b>A2</b> 松开状态	129	146.5	152	176	190
<b>B</b>	87	97	100	113	119.5
<b>C</b>	22	22	22	22	22
<b>E</b>	M10×1.5	M12×1.75	M16×2	M16×2	M20×2.5
<b>E1</b>	M18×1.5	M22×1.5	M28×1.5	M35×1.5	M43×1.5
<b>ΦE2</b>	23.5	28.5	35.5	45.5	54.5
<b>ΦE3</b>	27.7	33.5	43	53.1	63.5
<b>E4</b>	9	10	10	12	14
<b>F</b>	10	12	15	15	18
<b>G</b>	50	65	75	95	120
<b>H</b>	M45×1.5	M52×1.5	M60×1.5	M80×2.0	M90×2.0
<b>ΦH1</b>	43	50	58	78	88
<b>J1</b>	45	53	63	80	90
<b>J2</b>	65	73	85	100	115
<b>K1</b>	30	37	44	60	68
<b>K2</b>	50	57	65	80	90
<b>ΦL</b>	6.5	9	9	13	15
<b>M</b>	15	20	28	31	37.5
<b>N1</b>	13	14.5	16	19	25.5
<b>N2</b>	13	16	19.5	26.5	34
<b>O型圈(O-Ring(C type))</b>	P7	P7	P7	P7	P9

### 规格参数表 SPECIFICATIONS

型号	理论夹持力 (250 kgf/cm <sup>2</sup> ) CLAMPING FORCE AT 250 kgf/cm <sup>2</sup> (kgf)	转角行程	夹紧行程	总行程	拉入容积	推出容积	拉入受压面积	推出受压面积	使用温度范围	
MODEL	单动系列 Single acting	复动系列 Double acting	SWING STROKE (mm)	CLAMPING STROKE (mm)	TOTAL STROKE(mm)	CYLINDER CAPACITY CLAMP(cm <sup>3</sup> )	CYLINDER CAPACITY UNCLAMP(cm <sup>3</sup> )	EFFPISTON AREA CLAMP(cm <sup>2</sup> )	EFFPISTON AREA UNCLAMP(cm <sup>2</sup> )	RANGE OF TEMPERATURE(°C)
HPS-25	380	440	15	5	20	3.54	9.80	1.77	4.9	-10~+70°C
HPS-32	650	780	18	5	23	7.20	18.49	3.13	8.04	-10~+70°C
HPS-40	1140	1300	17.5	4.5	22	9.94	27.63	4.52	12.56	-10~+70°C
HPS-50	1580	1760	18.5	8.5	27	19.09	53.00	7.07	19.63	-10~+70°C
HPS-63	2560	2880	18	9	27	31.16	84.13	11.54	31.16	-10~+70°C

# SGYT-30

三杆一体旋转油压缸

## SGYT-30 THREE-ROD ROTARY HYDRAULIC SWING CLAMP



# S106-0P20

转向节专用油压转角缸

## S106-0P20 SPECIAL HYDRAULIC SWING CLAMP FOR STEERING KNUCKLE



### 产品特性

此旋转油缸具有三点下压夹紧功能，同时配件采用优化设计，使体积更加紧凑，提高了产品的强度。产品采用了专用防尘设计，提高了防尘和密封性，实现高密封性。

### FEATURES

The rotary hydraulic cylinder has a three-point downward clamping function, and the accessories are optimized to make the volume more compact and improve the strength of the product. The product adopts special dustproof design, improves dustproof and sealing, and achieves high sealing.

### 订购标示法 ORDERING INDICATION

示例: **SGYT-30R-90**

<b>SGYT-30</b>	系列 Series	SGYT-30
<b>R</b>	转角方向 Swing direction	L: 左旋 L: Left R: 右旋 R: Right
<b>90</b>	转角角度 Swing angle	90°

### 外形尺寸图

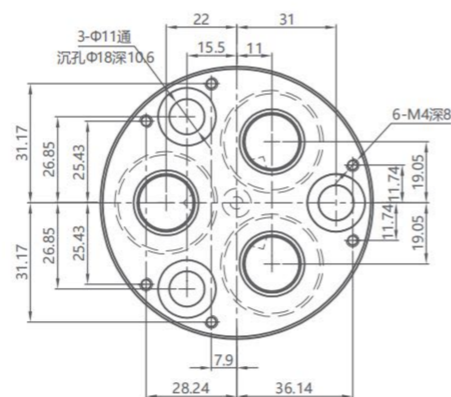
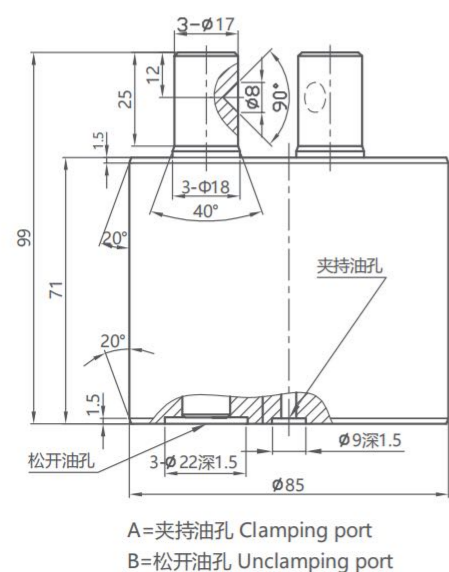

安装底座尺寸图

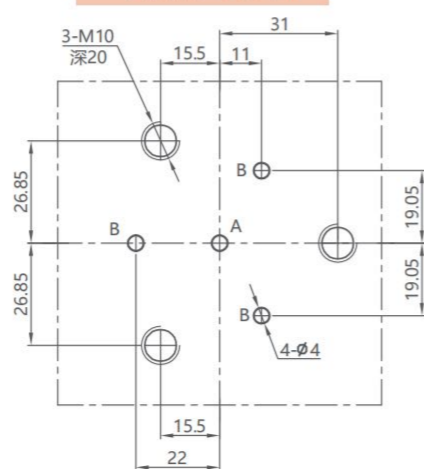

活塞杆径 PISTON ROD DIAMETER(mm)	油缸内径 HYDRAULIC CYLINDER INSIDE DIAMETER(mm)	转角行程 SWING STROKE (mm)	夹紧行程 CLAMPING STROKE (mm)	总行程 TOTAL STROKE (mm)	单个油缸压紧侧面积 AREA OF CLAMPING SIDE OF SINGLE CYLINDER(cm <sup>2</sup> )	使用压力范围 RANGE OF TEMPERATURE(MPa)
18mm	30mm	8	10	18	4.52	1.5-25

### 订购标示法 ORDERING INDICATION

示例: **S106-0P20**

### 规格参数表 SPECIFICATIONS

型号 MODEL	理论夹持力 (70kgf/cm <sup>2</sup> ) CLAMPING FORCE(70 kgf/cm <sup>2</sup> )	转角行程 SWING STROKE(mm)	夹紧行程 CLAMPING STROKE(mm)	拉入容积 CYLINDER CAPACITY CLAMP(cm <sup>3</sup> )	推出容积 CYLINDER CAPACITY UNCLAMP(cm <sup>3</sup> )	拉入受压面积 EFF.PISTON AREA CLAMP(cm <sup>2</sup> )	推出受压面积 EFF.PISTON AREA UNCLAMP(cm <sup>2</sup> )	使用压力范围 RANGE OF PRESSURE(MPa)	使用温度范围 RANGE OF TEMPERATURE(°C)
S106-0P20	3-343	15	25	3-19.6	3-32.16	3-4.9	3-8.04	3~7MPa	-10~+70°C
使用流体相当于ISO粘度等级的ISO-VG-32一般液压油 Recommended: ISO-VG-32 hydraulic oil equivalent to ISO viscosity grade									

松开状态

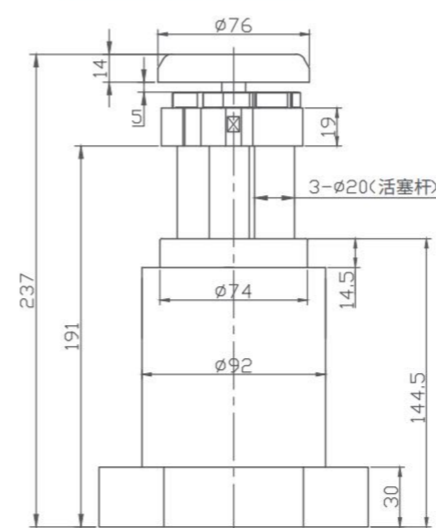

右转90°夹紧状态

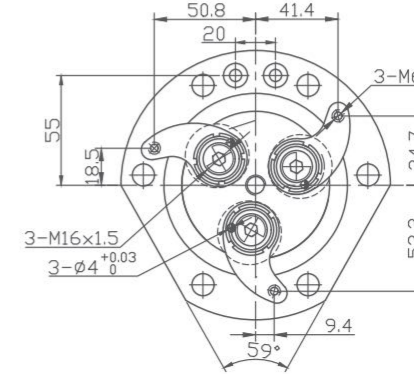
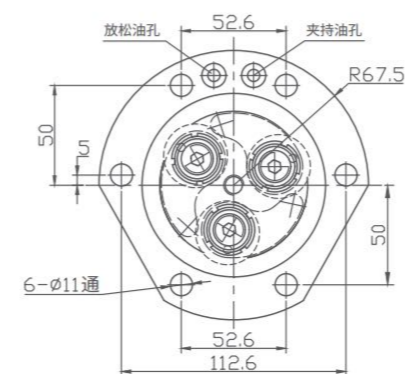
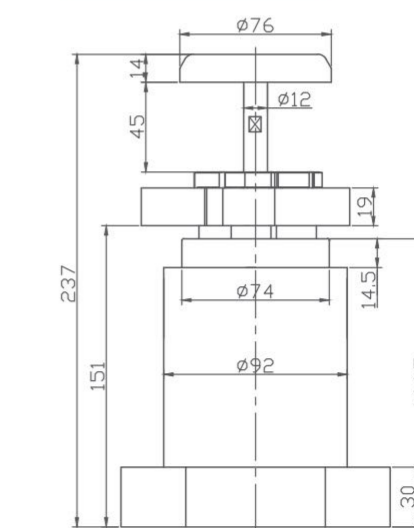

# CYZT

## 中心涨套油缸

### CYZT CENTRAL EXPANSION SLEEVE CYLINDER



#### 产品特性

通过液压力传递实现涨紧控制，结构简单，安全性高采用三活塞杆设计，通过同步运动确保涨紧力均匀。

最大操作压力: 70 kgf/cm<sup>2</sup>  
最小操作压力: 30 kgf/cm<sup>2</sup>

#### FEATURES

Tension control is achieved through hydraulic pressure transmission, featuring a simple structure and high safety. It adopts a three-piston rod design and ensures uniform tension force through synchronous operation.

Max.operating pressure:70 kgf/cm<sup>2</sup>  
Min.operating pressure:30 kgf/cm<sup>2</sup>

#### 注意事项

不可超出油缸的涨紧范围。

#### NOTE

Do not exceed the tensioning range of the cylinder.

#### 规格参数表 SPECIFICATIONS

型号	涨套涨紧范围	涨套行程	活塞杆径	油缸缸径	直线行程	转角行程(90°)	底部油口 附带O型圈	夹具供油口
CYZT-63-64	Ø63~Ø64	2	14	25	7	6.5	P6	≤Ø6

#### 外形尺寸 External Dimensions

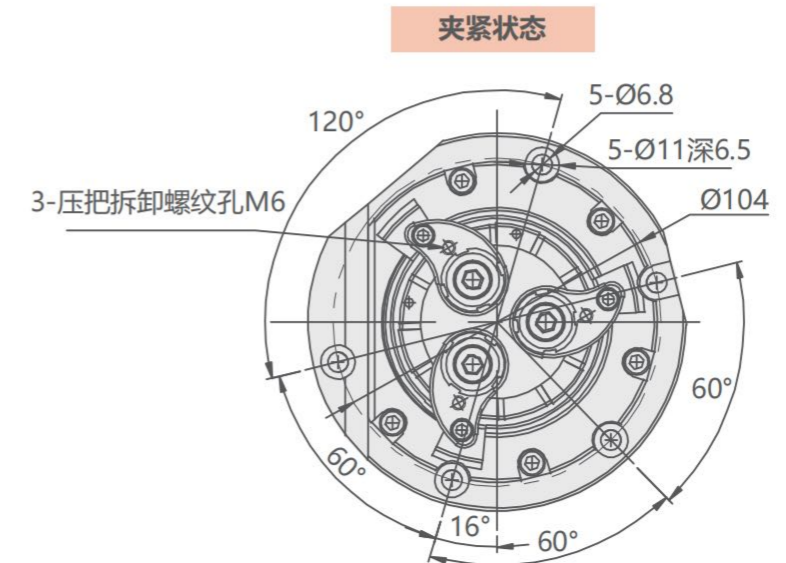
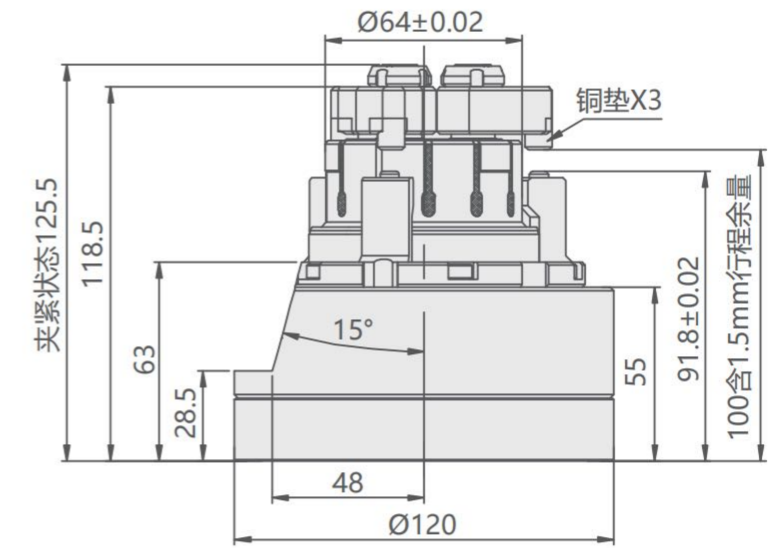
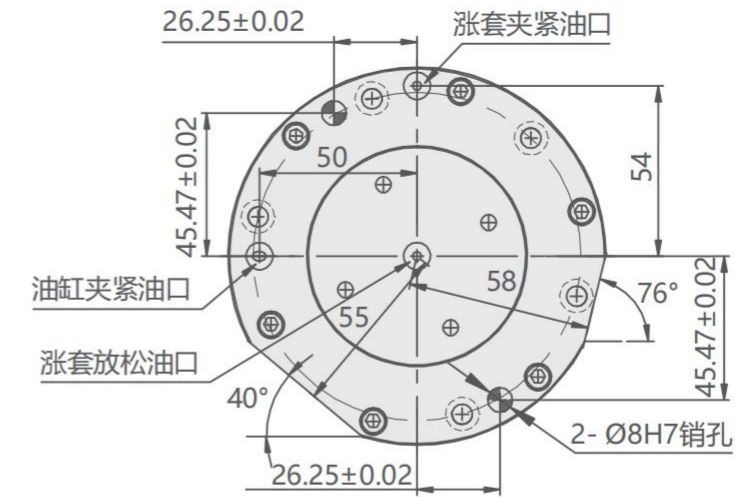

# CSP

## 油压支撑缸

### CSP HYDRAULIC SUPPORT CLAMP



CSP-30BLP

CSP-30BLK

CSP-30BLQ

#### 产品特性

- ★高支撑力:提高了活塞杆与夹套间的夹紧力,从而产生更高的工件支撑力。
- ★切削液清洁对策:为防止高压冷却液及切屑粉尘侵入内部结构而引发的动作不良,更换工件时可在排气孔进行空气清洁。空气清洁需要专用的气压回路。(建议清洁气压0.3~0.5MPa)
- ★通用的配管底座:可安装目前市售相同的日系缸规格,拥有互换性。

#### 液压上升型:

活塞杆初始状态为下降,供给油压使活塞杆上升并接触工件任意位置后停止,在停止的同时油压作用于夹套的夹紧力施加于活塞杆,使活塞杆得以稳固的支撑工件。

#### 弹簧上升型

活塞杆初始状态为上升,将工件放置于活塞杆上因工件的重量而下降到特定距离,此时供给油压作用于夹套的夹紧力施加于活塞杆,使活塞杆得以稳固的支撑工件。

#### 接触力与流量及压力关系

规格	油压(MPa)					
	流量(L/min)	3	4	5	6	7
CSP-26	5	0.2	0.2	0.2	0.2	0.2
	7	0.4	0.6	0.6	0.6	0.6
	10	1	1.2	1.2	1.2	1.2
CSP-30	5	0.4	0.4	0.4	0.4	0.4
	7	1.6	1.8	1.6	1.6	1.6
	10	3.4	3.4	3.4	3.6	3.6
CSP-36	5	0.2	0.2	0.2	0.2	0.2
	7	2	2	2.2	2	2
	10	2.4	2.4	2.4	2.4	2.4
CSP-45	5	0.6	0.4	0.4	0.4	0.4
	7	3.4	3.2	3.4	3.4	3.2
	10	4	4.2	4.4	4.2	4.2

测试条件为距离油缸4mm~5mm之最大接触力

#### FEATURES

**High Supporting Force:** The gap between the plunger and the collet is expanded to improve its overall performance, resulting in a higher supporting force.

**Cutting Fluid Cleaning Countermeasures:** To prevent improper operation caused by high-pressure coolant and chip dust from entering the internal structure, air cleaning can be performed in the exhaust hole when replacing the workpiece. Air cleaning requires a specific air pressure circuit (recommended cleaning air pressure at 0.3~0.5MPa).

**Universal piping base:** The CSP series is compatible and interchangeable with Japanese branded cylinders that are currently on the market.

#### Hydraulic Pressure Rising Type:

The initial state of the piston rod is down. When the oil pressure is supplied, the piston rod rises and stops once contact is made with the workpiece at any position. During this period, the hydraulic pressure on the collet can grip the plunger with stronger power to generate the supporting force.

#### Spring Rising Type:

The initial state of the piston rod is up, and the workpiece is placed on the piston rod and dropped to a certain distance due to the weight of the workpiece. During this period, the hydraulic pressure on the collet can grip the plunger with stronger power to generate the supporting force.

#### 油压与工件支撑力的关系

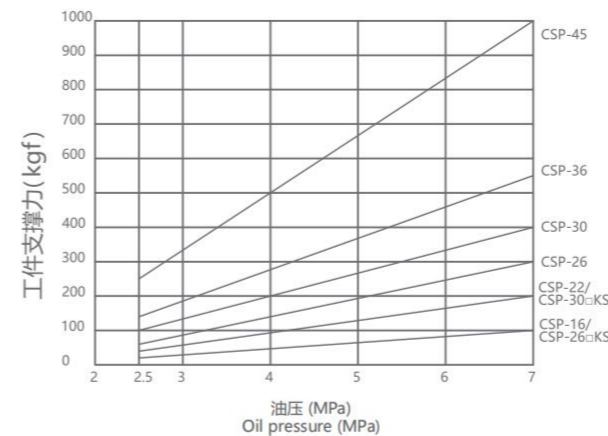

※本图表示静态负荷条件下的支持力。

#### 负荷与变位量的关系

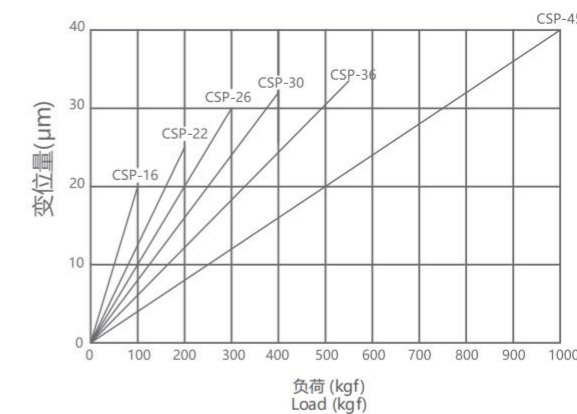

※本图表示供给油压7MPa条件下静态负荷下的变化

#### 订购标示法 ORDERING INDICATION

##### 示例: CSP-30BLK(MH)

CSP	系列 Series	CSP	
30	油缸外径 Oil cylinder external diameter	M16x1.5 M26x1.5 M30x1.5	M22x1.5 M36x1.5 M45x1.5
B	型式 Type	A:弹簧上升型 B:液压上升型(标准)	A: Spring rising type B: Hydraulic rising type (standard)
L	压强 Pressure	低压 7MPa	Low pressure 7MPa
K	版式 Format	K: K 标准版 P: P Type	KS: 短行程版 Q: 长行程版
M	气检式 Air sensing type	无记号:标准型 M:带气检	Unmarked: Standard type M: Air sensing type
H	活塞弹簧力 Piston spring force	无记号:标准型 H:强弹簧	Unmarked: Standard type H: Strong spring

#### 规格参数表 SPECIFICATIONS

型号	支撑力 (油压为7MPa时)	油缸容量	上升弹簧力	支撑杆行程	使用压力范围	帽盖最大允许质量	使用温度	质量	
MODEL	WORKPIECE SUPPORT FORCE (WHEN OIL PRESSURE IS 7MPa) (kgf)	OIL CYLINDER FLOW (cm <sup>3</sup> )	RISING SPRING FORCE (N)	PISTON ROD STROKE (mm)	RANGE OF PRESSURE (MPa)	MAX.ALLOWABLE MASS OF CAP(Kg)	OPERATING TEMPERATURE (°C)	Quality (kg)	
CSP-26	P/K	300	0.5	2~4	6.5	2.5~7	0.05	0~70	0.2
	KS	100	0.3	2~4	5	2.5~7	0.05	0~70	0.1
	Q	300	0.5	2~4	13	2.5~7	0.05	0~70	0.25
CSP-30	P/K	400	0.7	4~6	8	2.5~7	0.05	0~70	0.3
	KS	200	0.5	4~6	6	2.5~7	0.05	0~70	0.2
CSP-36	Q	400	0.7	4~6	16	2.5~7	0.05	0~70	0.35
	P/K	550	0.8	3~5	8	2.5~7	0.05	0~70	0.4
CSP-45	Q	550	0.8	3~5	16	2.5~7	0.05	0~70	0.5
	P/K	1000	2.3	3~6	10	2.5~7	0.05	0~70	0.7
Q	1000	2.3	3~6	20	2.5~7	0.05	0~70	0.9	

使用流体: 普通矿物油基液压油(相当于ISO-VG-32)

※1: 将支撑缸与夹套缸对置使用时为了使支撑力足够所使用的支撑缸支撑力应该为夹套缸与切削负荷的1.5倍以上请选择型号匹配的支撑缸与夹套缸

※2: 活塞杆上升弹簧力的数值表示弹簧设计值。该值会因活塞杆的滑动阻力、弹簧特性等而产生一定的偏差,所以上升弹簧力为参考值。

Recommended: ISO-VG-32 hydraulic oil equivalent to ISO viscosity grade

※1: When the support clamp and cylinder clamp are used opposite from each other, the supporting force must be 1.5 times the amount of the clamping force and cutting load in order for the support clamp to work sufficiently. Please check the compatibility of the support clamp and cylinder clamp when selecting parts.

※2: The plunger spring force indicates the spring design value. It may vary depending on sliding resistance of the plunger and characteristic of the spring, etc. Please use the rising spring force as a reference value.

CSP-ALK油压支撑缸外型尺寸图

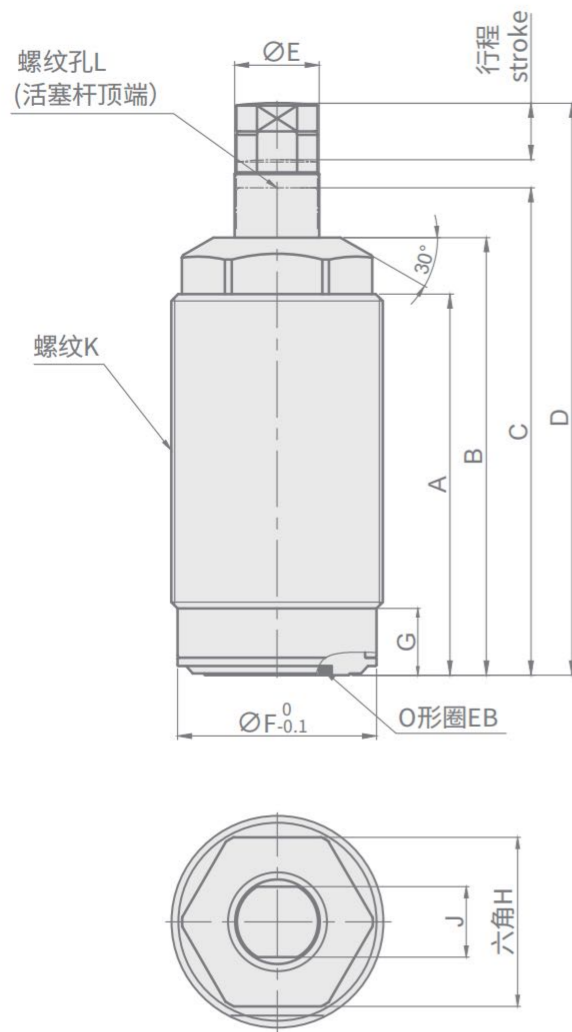

帽盖详图

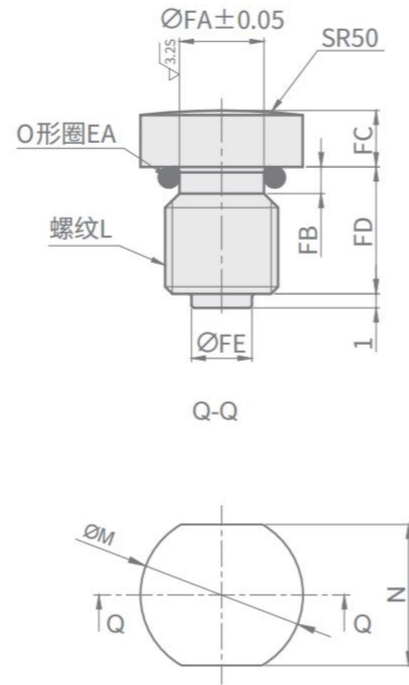

安装孔加工图

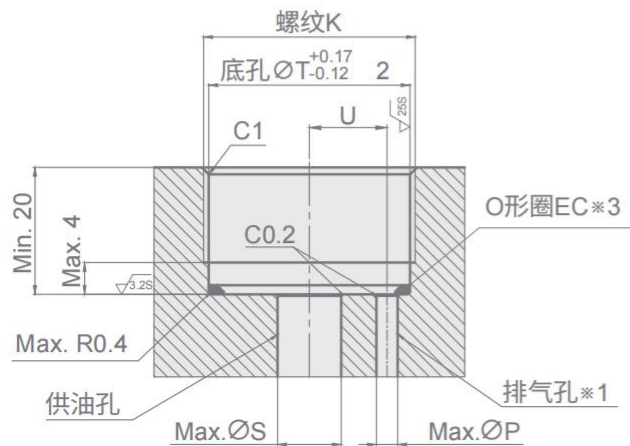

注意事项:

- ※1:排气孔必须向大气开放,且应注意防止冷却液切屑粉尘等侵入缸体内部。
- ※2:安装孔底面最大表面粗糙度应加工在3.2S以下。
- ※3:附带的O型圈EC要安装到安装孔内。

NOTE:

- ※: Vent hole must be open to the atmosphere, and attention should be paid to prevent coolant, chip dust and other intrusions into the cylinder body interior.
- ※2: The maximum surface roughness of the bottom of the installation hole shall be processed below 3.2S.
- ※3: The attached O-ring EC should be installed in the installation hole.

CSP-ALK油压支撑缸外型尺寸及安装部位加工尺寸表

Unit:mm

型号 Model No	CSP-16ALK	CSP-22ALK	CSP-26ALK	CSP-26ALKS	CSP-30ALK	CSP-30ALKS	CSP-36ALK	CSP-45ALK
A	29.1	45.6	48.6	32.1	51.4	31.9	47.4	57.4
B	39	51.3	55.8	38.3	60.1	39.1	56.1	69.1
C	48.5	63.5	63	50.5	77	54	73	88
D	50.5	66	72.5	53.5	81	58	77	92
ØE	5	7	10	10	12	12	15	16
ØF	14.7	20.2	24.3	24.3	28.2	28.2	34.2	43.2
G	5	7	9	9	10	10	10	10
H	13	18	22	22	24	24	30	36
J (活塞杆对边宽)	4.5	5.5	8	8	10	10	13	13
K (公称直径X螺距)	M16×1.0	M22×1.5	M26×1.5	M26×1.5	M30×1.5	M30×1.5	M36×1.5	M45×1.5
L (公称直径X螺距)	M3×0.5	M4×0.7	M6×1	M6×1	M8×1.25	M8×1.25	M10×1.5	M10×1.5
ØM	5	6.5	9.5	9.5	11.5	11.5	12.5	12.5
N (对边宽)	4.5	5.5	8	8	10	10	11	11
ØP	2	2.5	2.6	2.6	3	3	3	3
ØS	3	3.5	7.5	7.5	9	9	9	9
ØT	15	20.5	24.5	24.5	28.5	28.5	34.5	43.5
U	6	9	9	9	11	11	13	16
ØFA	2.2	3	4.5	4.5	6	6	7.8	7.8
FB	1	1	1.5	1.5	1.9	1.9	1.9	1.9
FC	2	2.5	3	3	4	4	4	4
FD	4	5.5	7.5	7.5	9	9	9	9
ØFE	1.5	2	3.5	3.5	4.3	4.3	5	5
O形圈EA (氟橡胶 硬度Hs70)	SS2.5	SS3	S5	S5	S6	S6	S8	S8
O形圈EB (氟橡胶 硬度Hs90)	S6	AS568-011	AS568-013	AS568-013	AS568-014	AS568-014	AS568-014	AS568-015
O形圈EC (氟橡胶 硬度Hs90)	S12	AS568-017	AS568-020	AS568-020	AS568-022	AS568-022	AS568-026	AS568-030

注意事项

- 1、请务必安装帽盖,否则工件接触弹簧将无法支撑工件,用户自制帽盖时,请参照帽盖详图,设置O型圈槽,另外,自制帽盖的质量请勿超过型录规定,请务必使用附带的O型圈,否则冷却液等异物会入侵缸体内部,导致动作异常等故障。
- 2、用户自制升起弹簧时,本公司不保证活塞杆正确动作。
- 3、如果O型圈破损或丢失,请务必参照型录上的O型圈规格,不可任意更换其他O型圈尺寸,若有需要请向本公司业务联系。
- 4、轻量工件及薄型工件的情况下,请根据需求临时固定工件,否则会有工件被顶起的现象。
- 5、空气清洁回路使用后,务必卸载气压,否则可能造成无法复位。
- 6、如果活塞杆上升速度过快,会造成活塞杆接触工件时出现反弹的现象,并在反弹位置处夹紧,使活塞杆与工件之间产生间隙或形成冲击,导致内部零件损坏。请通过单向流量控制阀来调整活塞杆的上升动作速度,使其上升动作时间在0.5~1秒以上,并确认活塞杆与工件之间没有间隙与冲击情况后再投入使用。
- 7、请使用开启压力为0.1MPa以下的带单向阀的流量调整阀。如果阀的开启压力过高,释放时活塞杆就无法复位。

NOTE

- 1、Be sure to install the cap. Otherwise, the workpiece will not be able to support the workpiece in contact with the spring. When the user makes the cap, please refer to the cap detailed drawing and set O-ring groove. In addition, the quality of the self-made caps should not exceed the requirements stipulated in the catalog. Please be sure to use the attached O-ring, otherwise, foreign bodies such as coolant will intrude into the cylinder body and cause abnormal operation and other faults.
- 2、The company does not guarantee the correct action of the piston rod when the user makes the rising spring by himself.
- 3、If the O-ring is damaged or lost, please refer to the specifications of O-ring in the catalogue, and do not change other O-ring sizes arbitrarily. If necessary, please contact our company.
- 4、In the case of light and thin workpiece, please fix the workpiece temporarily according to the demand, otherwise the workpiece will be damaged.
- 5、The return of cleaning air pressure will cause the piston rod to be unable to reset if air is supplied all the time.
- 6、If the piston rod rising speed is too fast, it will cause the phenomenon of rebound when the piston rod contacts the workpiece, and clamp at the rebound position, which will cause the gap or impact between the piston rod and the workpiece, leading to the damage of the internal parts. Please adjust the rising speed of the piston rod through one-way flow control valve so that the rising action time is more than 0.5-1 second, and confirm that there is no gap and impact between the piston rod and workpiece before putting into use.
- 7、Please use a flow control valve with a one-way valve under the opening pressure below 0.1MPa. If the opening pressure of the valve is too high, the piston rod cannot be reset when released.

CSP-BLK油压支撑缸外型尺寸图

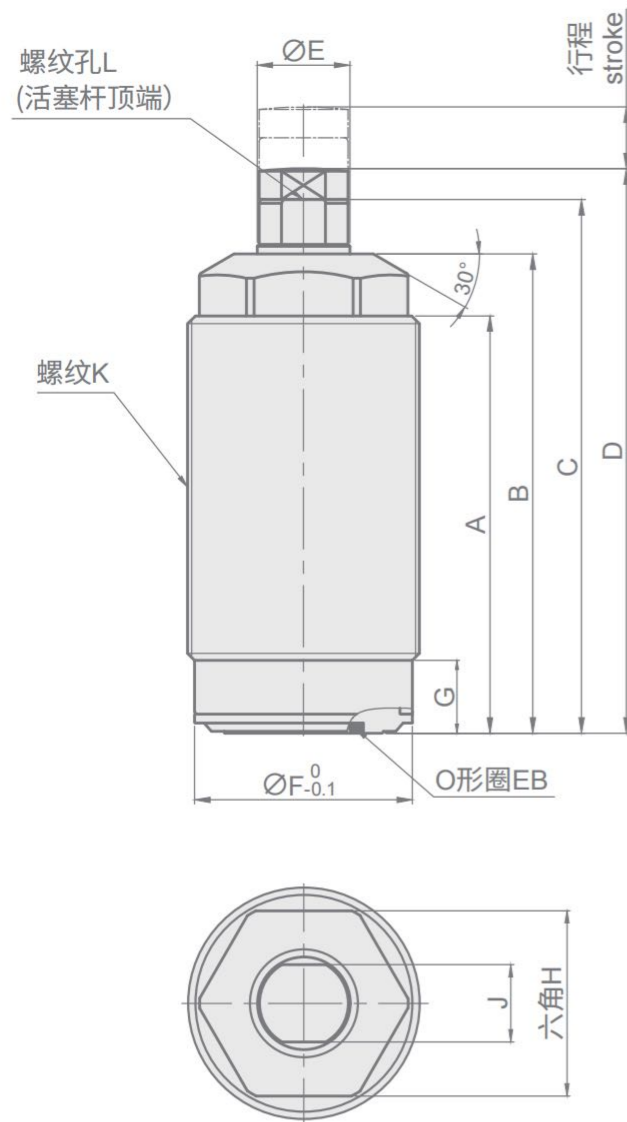

帽盖详图

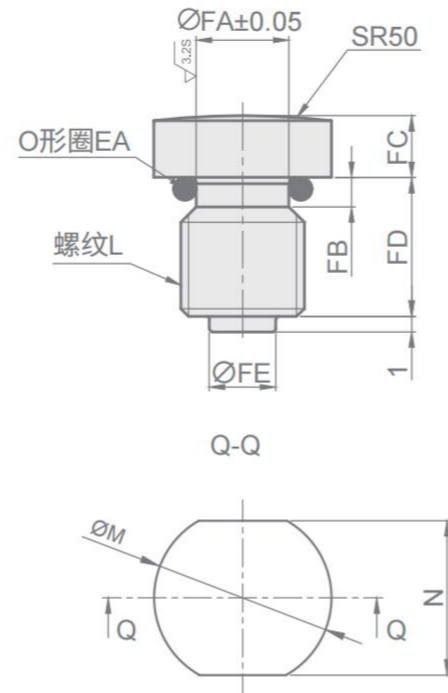

安装孔加工图

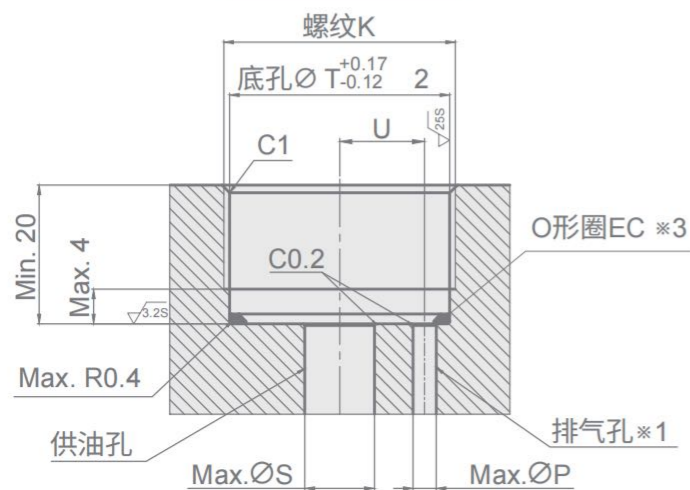

注意事项:

- ※1: 排气孔必须向大气开放, 且应注意防止冷却液切屑粉尘等侵入缸体内部。
- ※2: 安装孔底面最大表面粗糙度应加工在3.2S以下。
- ※3: 附带的O型圈EC要安装到安装孔内。

NOTE:

- ※1: Vent hole must be open to the atmosphere, and attention should be paid to prevent coolant, chip dust and other intrusions into the cylinder body interior.
- ※2: The maximum surface roughness of the bottom of the installation hole shall be processed below 3.2S.
- ※3: The attached O-ring EC should be installed in the installation hole.

CSP-BLK油压支撑缸外型尺寸及安装部位加工尺寸表

Unit:mm

型号 Model No	CSP-16BLK	CSP-22BLK	CSP-26BLK	CSP-26BLKS	CSP-30BLK	CSP-30BLKS	CSP-36BLK	CSP-45BLK
A	29.1	45.6	48.6	32.1	51.4	31.9	47.4	57.4
B	39	51.3	55.8	38.3	60.1	39.1	56.1	69.1
C	43.5	57	63	45.5	69	48	65	78
D	45.5	59.5	66	48.5	73	52	69	82
ØE	5	7	10	10	12	12	15	16
ØF	14.7	20.2	24.3	24.3	28.2	28.2	34.2	43.2
G	5	7	9	9	10	10	10	10
H	13	18	22	22	24	24	30	36
J (活塞杆对边宽)	4.5	5.5	8	8	10	10	13	13
K (公称直径X螺距)	M16×1.0	M22×1.5	M26×1.5	M26×1.5	M30×1.5	M30×1.5	M36×1.5	M45×1.5
L (公称直径X螺距)	M3×0.5	M4×0.7	M6×1	M6×1	M8×1.25	M8×1.25	M10×1.5	M10×1.5
ØM	5	6.5	9.5	9.5	11.5	11.5	12.5	12.5
N (对边宽)	4.5	5.5	8	8	10	10	11	11
ØP	2	2.5	2.6	2.6	3	3	3	3
ØS	3	3.5	7.5	7.5	9	9	9	9
ØT	15	20.5	24.5	24.5	28.5	28.5	34.5	43.5
U	6	9	9	9	11	11	13	16
ØFA	2.2	3	4.5	4.5	6	6	7.8	7.8
FB	1	1	1.5	1.5	1.9	1.9	1.9	1.9
FC	2	2.5	3	3	4	4	4	4
FD	4	5.5	7.5	7.5	9	9	9	9
ØFE	1.5	2	3.5	3.5	4.3	4.3	5	5
O形圈EA (氟橡胶 硬度Hs70)	SS2.5	SS3	S5	S5	S6	S6	S8	S8
O形圈EB (氟橡胶 硬度Hs90)	S6	AS568-011	AS568-013	AS568-013	AS568-014	AS568-014	AS568-014	AS568-015
O形圈EC (氟橡胶 硬度Hs90)	S12	AS568-017	AS568-020	AS568-020	AS568-022	AS568-022	AS568-026	AS568-030

注意事项

- 请务必安装帽盖, 否则工件接触弹簧将无法支撑工件, 用户自制帽盖时, 请参照帽盖详图, 设置O型圈槽, 另外, 自制帽盖的质量请勿超过型录规定, 请务必使用附带的O型圈, 否则冷却液等异物会入侵缸体内部, 导致动作异常等故障。
- 用户自制升起弹簧时, 本公司不保证活塞杆正确动作。
- 如果O型圈破损或丢失, 请务必参照型录上的O型圈规格, 不可任意更改其他O型圈尺寸, 若有需要请向本公司业务联系。
- 轻量工件及薄型工件的情况下, 请根据需求临时固定工件, 否则会有工件被顶起的现象。
- 空气清洁回路使用后, 务必卸载气压, 否则可能造成无法复位。
- 如果活塞杆上升速度过快, 会造成活塞杆接触工件时出现反弹的现象, 并在回弹位置处夹紧, 使活塞杆与工件之间产生间隙或形成冲击, 导致内部零件损坏。请通过单向流量控制阀来调整活塞杆的上升动作速度, 使其上升动作时间在0.5~1秒以上, 并确认活塞杆与工件之间没有间隙与冲击情况后再投入使用。
- 请使用开启压力为0.1MPa以下的带单向阀的流量调整阀。如果阀的开启压力过高, 释放时活塞杆就无法复位。

NOTE

- Be sure to install the cap. Otherwise, the workpiece will not be able to support the workpiece in contact with the spring. When the user makes the cap, please refer to the cap detailed drawing and set O-ring groove. In addition, the quality of the self-made caps should not exceed the requirements stipulated in the catalog. Please be sure to use the attached O-ring, otherwise, foreign bodies such as coolant will intrude into the cylinder body and cause abnormal operation and other faults.
- The company does not guarantee the correct action of the piston rod when the user makes the rising spring by himself.
- If the O-ring is damaged or lost, please refer to the specifications of O-ring in the catalogue, and do not change other O-ring sizes arbitrarily. If necessary, please contact our company.
- In the case of light and thin workpiece, please fix the workpiece temporarily according to the demand, otherwise the workpiece will be damaged.
- The return of cleaning air pressure will cause the piston rod to be unable to reset if air is supplied all the time.
- If the piston rod rising speed is too fast, it will cause the phenomenon of rebound when the piston rod contacts the workpiece, and clamp at the rebound position, which will cause the gap or impact between the piston rod and the workpiece, leading to the damage of the internal parts. Please adjust the rising speed of the piston rod through one-way flow control valve so that the rising action time is more than 0.5-1 second, and confirm that there is no gap and impact between the piston rod and workpiece before putting into use.
- Please use a flow control valve with a one-way valve under the opening pressure below 0.1MPa. If the opening pressure of the valve is too high, the piston rod cannot be reset when released.

CSP-ALP油压支撑缸外型尺寸图

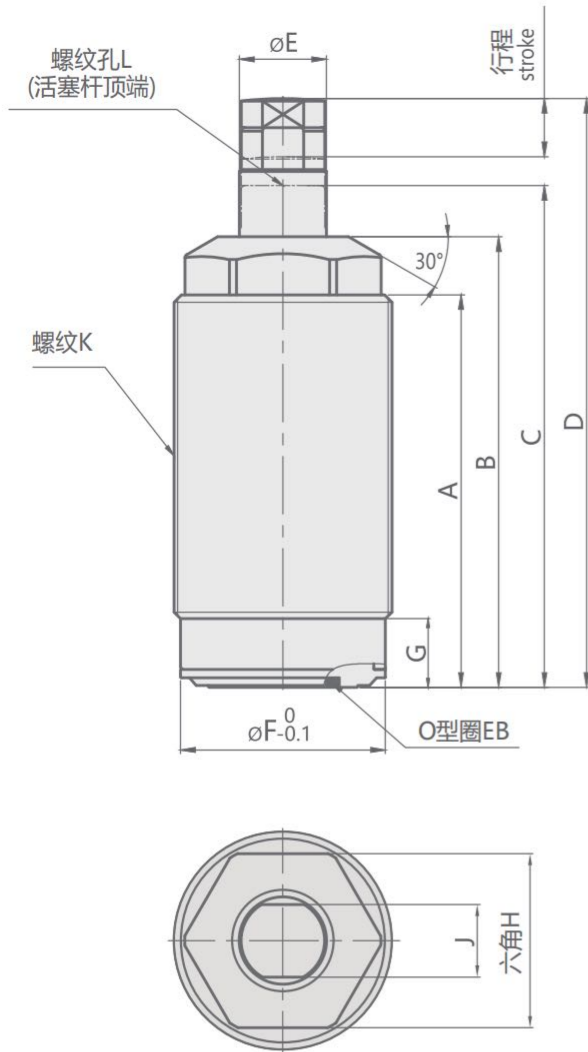

帽盖详图

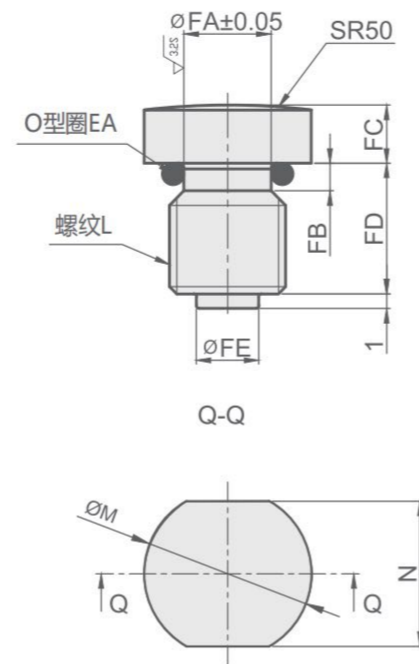

安装孔加工图

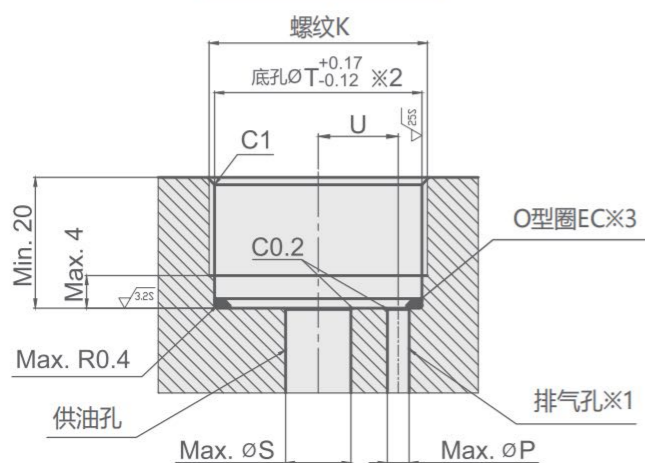

**注意事项:**

- ※1: 排气孔必须向大气开放, 且应注意防止冷却液切屑粉尘等侵入缸体内部。
- ※2: 安装孔底面最大表面粗糙度应加工在3.2S以下。
- ※3: 附带的O型圈EC要安装到安装孔内。

**NOTE:**

- ※1: Vent hole must be open to the atmosphere, and attention should be paid to prevent coolant, chip dust and other intrusions into the cylinder body interior
- ※2: The maximum surface roughness of the bottom of the installation hole shall be processed below 3.2S.
- ※3: The attached O-ring EC should be installed in the installation hole.

**注意事项**

- 1、请务必安装帽盖, 否则工件接触弹簧将无法支撑工件, 用户自制帽盖时, 请参照帽盖详图, 设置O型圈槽, 另外, 自制帽盖的质量请勿超过型录规定, 请务必使用附带的O型圈, 否则冷却液等异物会入侵缸体内部, 导致动作异常等故障。
- 2、用户自制升起弹簧时, 本公司不保证活塞杆正确动作。
- 3、如果O型圈破损或丢失, 请务必参照型录上的O型圈规格, 不可任意更换其他O型圈尺寸, 若有需要请向本公司业务联系。
- 4、轻量工件及薄型工件的情况下, 请根据需求临时固定工件, 否则会有工件被顶起的现象。
- 5、空气清洁回路使用后, 务必卸载气压, 否则可能造成无法复位。
- 6、如果活塞杆上升速度过快, 会造成活塞杆接触工件时出现反弹的现象, 并在反弹位置处夹紧, 使活塞杆与工件之间产生间隙或形成冲击, 导致内部零件损坏。请通过单向流量控制阀来调整活塞杆的上升动作速度, 使其上升动作时间在0.5~1秒以上, 并确认活塞杆与工件之间没有间隙与冲击情况后投入。
- 7、请使用开启压力为0.1MPa以下的带单向阀的流量调整阀。如果阀的开启压力过高, 释放时活塞杆就无法复位。

**NOTE**

- 1、Be sure to install the cap. Otherwise, the workpiece will not be able to support the workpiece in contact with the spring. When the user makes the cap, please refer to the cap detailed drawing and set O-ring groove. In addition, the quality of the self-made caps should not exceed the requirements stipulated in the catalog. Please be sure to use the attached O-ring, otherwise, foreign bodies such as coolant will intrude into the cylinder body and cause abnormal operation and other faults.
- 2、The company does not guarantee the correct action of the piston rod when the user makes the rising spring by himself.
- 3、If the O-ring is damaged or lost, please refer to the specifications of O-ring in the catalogue, and do not change other O-ring sizes arbitrarily. If necessary, please contact our company.
- 4、In the case of light and thin workpiece, please fix the workpiece temporarily according to the demand, otherwise the workpiece will be damaged.
- 5、The return of cleaning air pressure will cause the piston rod to be unable to reset if air is supplied all the time.
- 6、If the piston rod rising speed is too fast, it will cause the phenomenon of rebound when the piston rod contacts the workpiece, and clamp at the rebound position, which will cause the gap or impact between the piston rod and the workpiece, leading to the damage of the internal parts. Please adjust the rising speed of the piston rod through one-way flow control valve so that the rising action time is more than 0.5-1 second, and confirm that there is no gap and impact between the piston rod and workpiece before putting into use.
- 7、Please use a flow control valve with a one-way valve under the opening pressure below 0.1MPa. If the opening pressure of the valve is too high, the piston rod cannot be reset when released.

型号 Model No	CSP-16ALP	CSP-22ALP	CSP-26ALP	CSP-30ALP	CSP-36ALP	CSP-45ALP
A	29.1	45.6	49	54	48	60
B	39	51.3	57	62	58	71
C	48.5	63.5	69.5	77	73	88
D	50.5	66	72.5	81	77	92
ØE	5	7	10	12	15	16
ØF	14.7	20.2	24.3	28.2	34.2	43.2
G	5	7	9	10	10	10
H	13	18	22	24	30	36
J(活塞杆对边宽)	4.5	5.5	8	10	13	13
K(公称直径X螺距)	M16×1.0	M22×1.5	M26×1.5	M30×1.5	M36×1.5	M45×1.5
L(公称直径X螺距)	M3×0.5	M4×0.7	M6×1	M8×1.25	M10×1.5	M10×1.5
ØM	5	6.5	9.5	11.5	12.5	12.5
N(对边宽)	4.5	5.5	8	10	11	11
ØP	2	2.5	2.6	3	3	3
ØS	3	3.5	7.5	9	9	9
ØT	15	20.5	24.5	28.5	34.5	43.5
U	6	9	9	11	13	16
ØFA	2.2	3	4.5	6	7.8	7.8
FB	1	1	1.5	1.9	1.9	1.9
FC	2	2.5	3	4	4	4
FD	4	5.5	7.5	9	9	9
ØFE	1.5	2	3.5	4.3	5	5
O型圈EA (氟橡胶 硬度Hs70)	SS2.5	SS3	S5	S6	S8	S8
O型圈EB (氟橡胶 硬度Hs90)	S6	AS568-011	AS568-013	AS568-014	AS568-014	AS568-015
O型圈EC (氟橡胶硬度Hs90)	S12	AS568-017	AS568-020	AS568-022	AS568-026	AS568-030

CSP-BLP油压支撑缸外型尺寸图

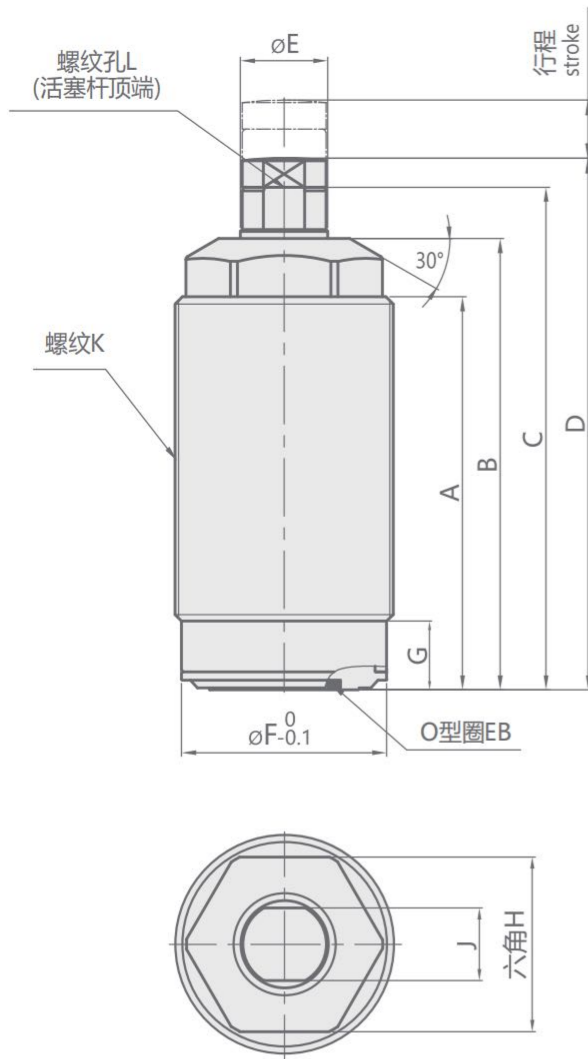

帽盖详图

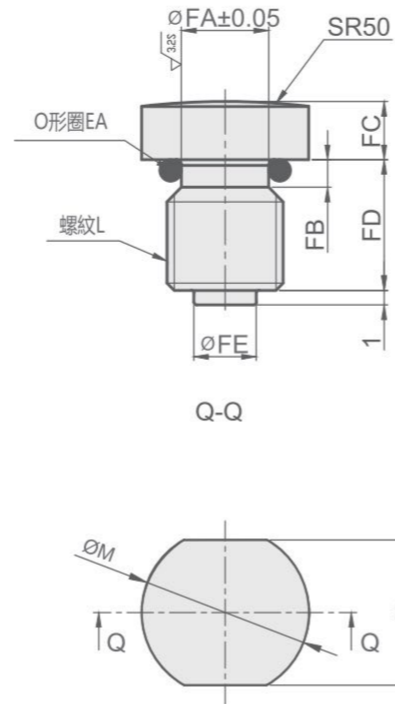

安装孔加工图

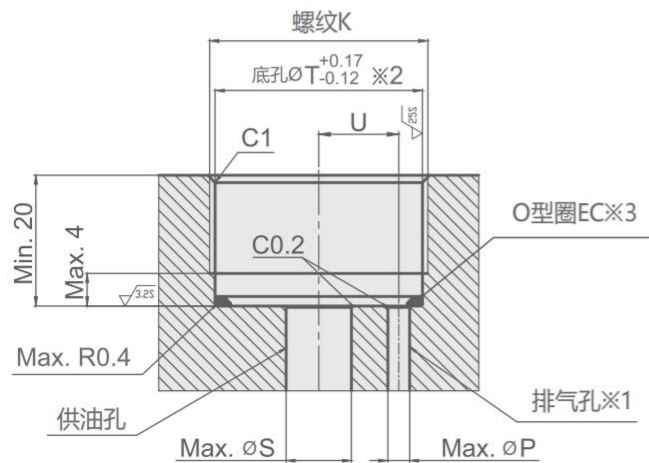

**注意事项:**

- ※1: 排气孔必须向大气开放, 且应注意防止冷却液切屑粉尘等侵入缸体内部。
- ※2: 安装孔底面最大表面粗糙度应加工在3.2S以下。
- ※3: 附带的O型圈EC要安装到安装孔内。

**NOTE:**

- ※1: Vent hole must be open to the atmosphere, and attention should be paid to prevent coolant, chip dust and other intrusions into the cylinder body interior.
- ※2: The maximum surface roughness of the bottom of the installation hole shall be processed below 3.2S.
- ※3: The attached O-ring EC should be installed in the installation hole.

CSP-BLP油压支撑缸外型尺寸及安装部位加工尺寸表

Unit:mm

型号 Model No	CSP-16BLP	CSP-22BLP	CSP-26BLP	CSP-30BLP	CSP-36BLP	CSP-45BLP
A	29.1	45.6	49	54	48	60
B	39	51.3	57	62	58	71
C	43.5	57	63	69	65	78
D	45.5	59.5	66	73	69	82
ØE	5	7	10	12	15	16
ØF	14.7	20.2	24.3	28.2	34.2	43.2
G	5	7	9	10	10	10
H	13	18	22	24	30	36
J(活塞杆对边宽)	4.5	5.5	8	10	13	13
K(公称直径X螺距)	M16×1.0	M22×1.5	M26×1.5	M30×1.5	M36×1.5	M45×1.5
L(公称直径X螺距)	M3×0.5	M4×0.7	M6×1	M8×1.25	M10×1.5	M10×1.5
ØM	5	6.5	9.5	11.5	12.5	12.5
N(对边宽)	4.5	5.5	8	10	11	11
ØP	2	2.5	2.6	3	3	3
ØS	3	3.5	7.5	9	9	9
ØT	15	20.5	24.5	28.5	34.5	43.5
U	6	9	9	11	13	16
ØFA	22	3	4.5	6	7.8	7.8
FB	1	1	1.5	1.9	1.9	1.9
FC	2	2.5	3	4	4	4
FD	4	5.5	7.5	9	9	9
ØFE	1.5	2	3.5	4.3	5	5
O型圈EA (氟橡胶 硬度Hs70)	SS2.5	SS3	S5	S6	S8	S8
O型圈EB (氟橡胶 硬度Hs90)	S6	AS568-011	AS568-013	AS568-014	AS568-014	AS568-015
O型圈EC (氟橡胶硬度Hs90)	S12	AS568-017	AS568-020	AS568-022	AS568-026	AS568-030

**注意事项**

1. 请务必安装帽盖, 否则工件接触弹簧将无法支撑工件, 用户自制帽盖时, 请参照帽盖详图, 设置O型圈槽, 另外, 自制帽盖的质量请勿超过型录规定, 请务必使用附带的O型圈, 否则冷却液等异物会侵入缸体内部, 导致动作异常等故障。
2. 用户自制升起弹簧时, 本公司不保证活塞杆正确动作。
3. 如果O型圈破损或丢失, 请务必参照型录上的O型圈规格, 不可任意更换其他O型圈尺寸, 若有需要请向本公司业务联系。
4. 轻量工件及薄型工件的情况下, 请根据需求临时固定工件, 否则会有工件被顶起的现象。
5. 空气清洁回路使用后, 务必卸载气压, 否则可能造成无法复位。
6. 如果活塞杆上升速度过快, 会造成活塞杆接触工件时出现反弹的现象, 并在反弹位置处夹紧, 使活塞杆与工件之间产生间隙或形成冲击, 导致内部零件损坏。请通过单向流量控制阀来调整活塞杆的上升动作速度, 使其上升动作时间在0.5~1秒以上, 并确认活塞杆与工件之间没有间隙与冲击情况后再次投入使用。
7. 请使用开启压力为0.1MPa以下的带单向阀的流量调整阀。如果阀的开启压力过高, 释放时活塞杆就无法复位。

**NOTE**

1. Be sure to install the cap. Otherwise, the workpiece will not be able to support the workpiece in contact with the spring. When the user makes the cap, please refer to the cap detailed drawing and set O-ring groove. In addition, the quality of the self-made caps should not exceed the requirements stipulated in the catalog. Please be sure to use the attached O-ring, otherwise, foreign bodies such as coolant will intrude into the cylinder body and cause abnormal operation and other faults.
2. The company does not guarantee the correct action of the piston rod when the user makes the rising spring by himself.
3. If the O-ring is damaged or lost, please refer to the specifications of O-ring in the catalogue, and do not change other O-ring sizes arbitrarily. If necessary, please contact our company.
4. In the case of light and thin workpiece, please fix the workpiece temporarily according to the demand, otherwise the workpiece will be damaged.
5. The return of cleaning air pressure will cause the piston rod to be unable to reset if air is supplied all the time.
6. If the piston rod rising speed is too fast, it will cause the phenomenon of rebound when the piston rod contacts the workpiece, and clamp at the rebound position, which will cause the gap or impact between the piston rod and the workpiece, leading to the damage of the internal parts. Please adjust the rising speed of the piston rod through one-way flow control valve so that the rising action time is more than 0.5-1 second, and confirm that there is no gap and impact between the piston rod and workpiece before putting into use.
7. Please use a flow control valve with a one-way valve under the opening pressure below 0.1MPa. If the opening pressure of the valve is too high, the piston rod cannot be reset when released.

### CSP-ALQ外形尺寸

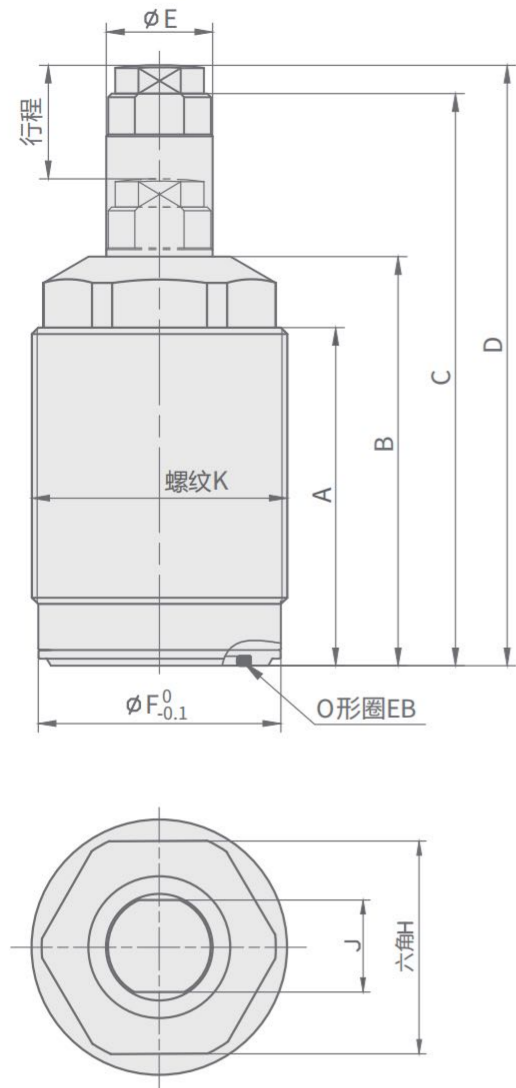

### 帽盖详图

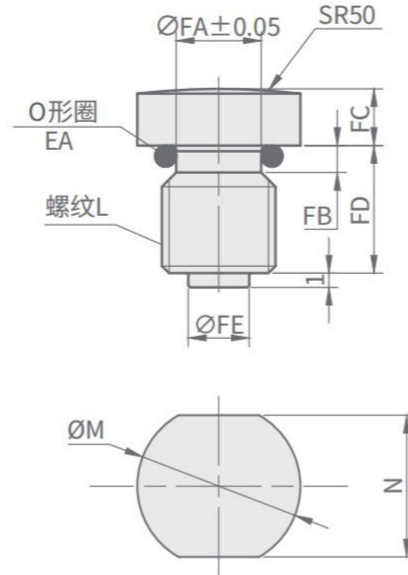

### 安装孔加工图

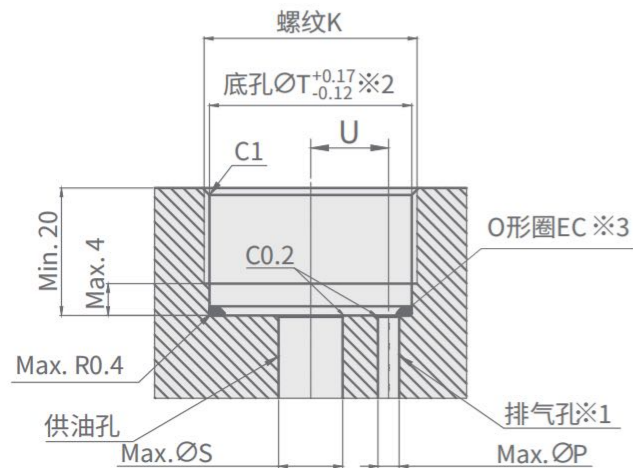

#### 注意事项:

- ※1:排气孔必须向大气开放,且应注意防止冷却液切屑粉尘等侵入缸体内部。
- ※2:安装孔底面最大表面粗糙度应加工在3.2S以下。
- ※3:附带的O型圈EC要安装到安装孔内。

#### NOTE:

- ※: Vent hole must be open to the atmosphere, and attention should be paid to prevent coolant, chip dust and other intrusions into the cylinder body interior.
- ※2: The maximum surface roughness of the bottom of the installation hole shall be processed below 3.2S.
- ※3: The attached O-ring EC should be installed in the installation hole.

### CSP-ALQ油压支撑缸外型尺寸及安装部位加工尺寸表

Unit:mm

型号 Model No	CSP-26ALQ	CSP-30ALQ	CSP-36ALQ	CSP-45ALQ
A	49	54	48	60
B	57	62	58	71
C	76	85	81	98
D	79	89	85	102
ØE	10	12	15	16
ØF	24.3	28.2	34.2	43.2
G	9	10	10	10
H	22	24	30	36
J(活塞杆对边宽)	8	10	13	13
K(公称直径X螺距)	M26X1.5	M30X1.5	M36X1.5	M45X1.5
L(公称直径X螺距)	M6X1	M8X1.25	M10X1.5	M10X1.5
ØM	9.5	11.5	12.5	12.5
N(对边宽)	8	10	11	11
ØP	2.6	3	3	3
ØS	7.5	9	9	9
ØT	24.5	28.5	34.5	43.5
U	9	11	13	16
ØFA	4.5	6	7.8	7.8
FB	1.5	1.9	1.9	1.9
FC	3	4	4	4
FD	7.5	9	9	9
ØFE	3.5	4.3	5	5
O型圈EA (氟橡胶 硬度Hs70)	S5	S6	S8	S8
O型圈EB (氟橡胶 硬度Hs90)	AS568-013	AS568-014	AS568-014	AS568-015
O型圈EC (氟橡胶硬度Hs90)	AS568-020	AS568-022	AS568-026	AS568-030

#### 注意事项

- 1、请务必安装帽盖,否则工件接触弹簧将无法支撑工件,用户自制帽盖时,请参照帽盖详图,设置O型圈槽,另外,自制帽盖的质量请勿超过型录规定,请务必使用附带的O型圈,否则冷却液等异物会侵入缸体内部,导致动作异常等故障。
- 2、用户自制升起弹簧时,本公司不保证活塞杆正确动作。
- 3、如果O型圈破损或丢失,请务必参照型录上的O型圈规格,不可任意更换其他O型圈尺寸,若有需要请向本公司业务联系。
- 4、轻量工件及薄型工件的情况下,请根据需求临时固定工件,否则会有工件被顶起的现象。
- 5、空气清洁回路使用后,务必卸载气压,否则可能造成无法复位。
- 6、如果活塞杆上升速度过快,会造成活塞杆接触工件时出现反弹的现象,并在回弹位置处夹紧,使活塞杆与工件之间产生间隙或形成冲击,导致内部零件损坏。请通过单向流量控制阀来调整活塞杆的上升动作速度,使其上升动作时间在0.5~1秒以上,并确认活塞杆与工件之间没有间隙与冲击情况后再次投入使用。
- 7、请使用开启压力为0.1MPa以下的带单向阀的流量调整阀。如果阀的开启压力过高,释放时活塞杆就无法复位。

#### NOTE

- 1、Be sure to install the cap. Otherwise, the workpiece will not be able to support the workpiece in contact with the spring. When the user makes the cap, please refer to the cap detailed drawing and set O-ring groove. In addition, the quality of the self-made caps should not exceed the requirements stipulated in the catalog. Please be sure to use the attached O-ring, otherwise, foreign bodies such as coolant will intrude into the cylinder body and cause abnormal operation and other faults.
- 2、The company does not guarantee the correct action of the piston rod when the user makes the rising spring by himself.
- 3、If the O-ring is damaged or lost, please refer to the specifications of O-ring in the catalogue, and do not change other O-ring sizes arbitrarily. If necessary, please contact our company.
- 4、In the case of light and thin workpiece, please fix the workpiece temporarily according to the demand, otherwise the workpiece will be damaged.
- 5、The return of cleaning air pressure will cause the piston rod to be unable to reset if air is supplied all the time.
- 6、If the piston rod rising speed is too fast, it will cause the phenomenon of rebound when the piston rod contacts the workpiece, and clamp at the rebound position, which will cause the gap or impact between the piston rod and the workpiece, leading to the damage of the internal parts. Please adjust the rising speed of the piston rod through one-way flow control valve so that the rising action time is more than 0.5-1 second, and confirm that there is no gap and impact between the piston rod and workpiece before putting into use.
- 7、Please use a flow control valve with a one-way valve under the opening pressure below 0.1MPa. If the opening pressure of the valve is too high, the piston rod cannot be reset when released.

### CSP-BLQ外形尺寸

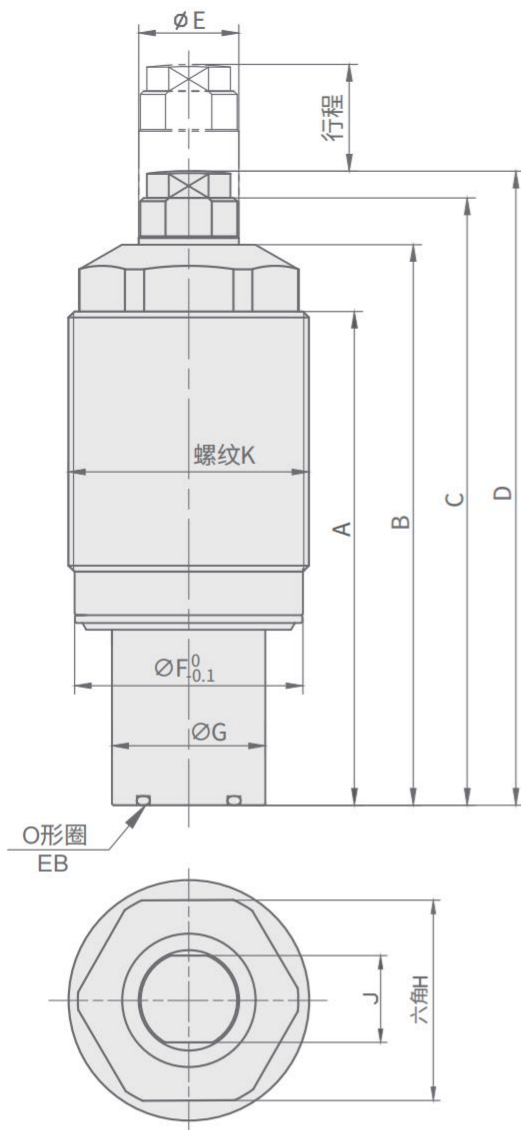

### 帽盖详图

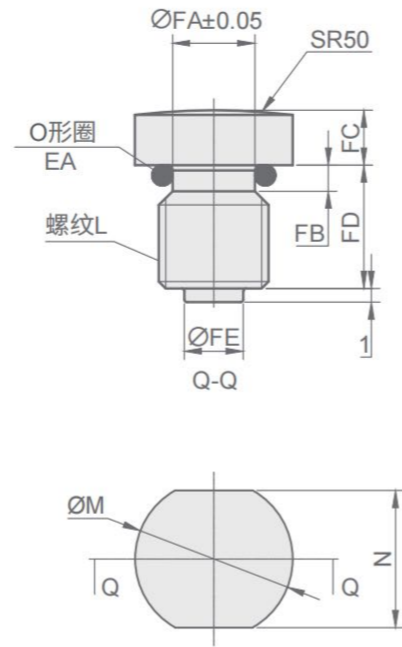

### 安装孔加工图

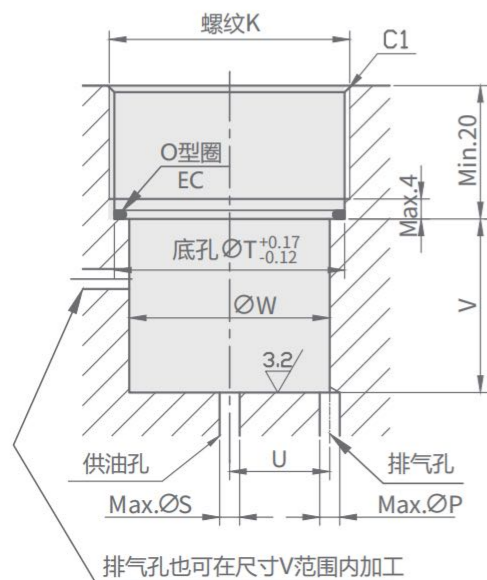

### 注意事项:

- ※1:排气孔必须向大气开放,且应注意防止冷却液切屑粉尘等侵入缸体内部。
- ※2:安装孔底面最大表面粗糙度应加工在3.2S以下。
- ※3:附带的O型圈EC要安装到安装孔内。

### NOTE:

- ※: Vent hole must be open to the atmosphere, and attention should be paid to prevent coolant, chip dust and other intrusions into the cylinder body interior.
- ※2: The maximum surface roughness of the bottom of the installation hole shall be processed below 3.2S.
- ※3: The attached O-ring EC should be installed in the installation hole.

### CSP-BLQ油压支撑缸外型尺寸及安装部位加工尺寸表

Unit:mm

型号 Model No	CSP-26BLQ	CSP-30BLQ	CSP-36BLQ	CSP-45BLQ
A	66	73.5	74	90
B	74	81.5	84	101
C	80	88.5	91	108
D	83	92.5	95	112
ØE	10	12	15	16
ØF	24.3	28.2	34.2	43.2
G	18.5	21	23	25
H	22	24	30	36
J(活塞杆对边宽)	8	10	13	13
K(公称直径X螺距)	M26X1.5	M30X1.5	M36X1.5	M45X1.5
L(公称直径X螺距)	M6X1	M8X1.25	M10X1.5	M10X1.5
ØM	9.5	11.5	12.5	12.5
N(对边宽)	8	10	11	11
ØP	2.6	3	3	3
ØS	7.5	9	9	9
ØT	24.5	28.5	34.5	43.5
U	10	11	13	16
V	17	19.5	26	30
W	20	24	30	39
ØFA	4.5	6	7.8	7.8
FB	1.5	1.9	1.9	1.9
FC	3	4	4	4
FD	7.5	9	9	9
ØFE	3.5	4.3	5	5
O型圈EA (氟橡胶 硬度Hs70)	S5	S6	S8	S8
O型圈EB (氟橡胶 硬度Hs90)	AS568-014	AS568-014	AS568-016	AS568-015
O型圈EC (氟橡胶硬度Hs90)	AS568-020	AS568-022	AS568-026	AS568-030

### 注意事项

- 1、请务必安装帽盖,否则工件接触弹簧将无法支撑工件,用户自制帽盖时,请参照帽盖详图,设置O型圈槽,另外,自制帽盖的质量请勿超过型录规定,请务必使用附带的O型圈,否则冷却液等异物会侵入缸体内部,导致动作异常等故障。
- 2、用户自制升起弹簧时,本公司不保证活塞杆正确动作。
- 3、如果O型圈破损或丢失,请务必参照型录上的O型圈规格,不可任意更换其他O型圈尺寸,若有需要请向本公司业务联系。
- 4、轻量工件及薄型工件的情况下,请根据需求临时固定工件,否则会有工件被顶起的现象。
- 5、空气清洁回路使用后,务必卸载气压,否则可能造成无法复位。
- 6、如果活塞杆上升速度过快,会造成活塞杆接触工件时出现反弹的现象,并在反弹位置处夹紧,使活塞杆与工件之间产生间隙或形成冲击,导致内部零件损坏。请通过单向流量控制阀来调整活塞杆的上升动作速度,使其上升动作时间在0.5~1秒以上,并确认活塞杆与工件之间没有间隙与冲击情况后投入使用。
- 7、请使用启开压力为0.1MPa以下的带单向阀的流量调整阀。如果阀的启开压力过高,释放时活塞杆就无法复位。

### NOTE

- 1、Be sure to install the cap. Otherwise, the workpiece will not be able to support the workpiece in contact with the spring. When the user makes the cap, please refer to the cap detailed drawing and set O-ring groove. In addition, the quality of the self-made caps should not exceed the requirements stipulated in the catalog. Please be sure to use the attached O-ring, otherwise, foreign bodies such as coolant will intrude into the cylinder body and cause abnormal operation and other faults.
- 2、The company does not guarantee the correct action of the piston rod when the user makes the rising spring by himself.
- 3、If the O-ring is damaged or lost, please refer to the specifications of O-ring in the catalogue, and do not change other O-ring sizes arbitrarily. If necessary, please contact our company.
- 4、In the case of light and thin workpiece, please fix the workpiece temporarily according to the demand, otherwise the workpiece will be damaged.
- 5、The return of cleaning air pressure will cause the piston rod to be unable to reset if air is supplied all the time.
- 6、If the piston rod rising speed is too fast, it will cause the phenomenon of rebound when the piston rod contacts the workpiece, and clamp at the rebound position, which will cause the gap or impact between the piston rod and the workpiece, leading to the damage of the internal parts. Please adjust the rising speed of the piston rod through one-way flow control valve so that the rising action time is more than 0.5-1 second, and confirm that there is no gap and impact between the piston rod and workpiece before putting into use.
- 7、Please use a flow control valve with a one-way valve under the opening pressure below 0.1MPa. If the opening pressure of the valve is too high, the piston rod cannot be reset when released.

CSP-□M油压上顶型  
气检支撑缸外形尺寸图

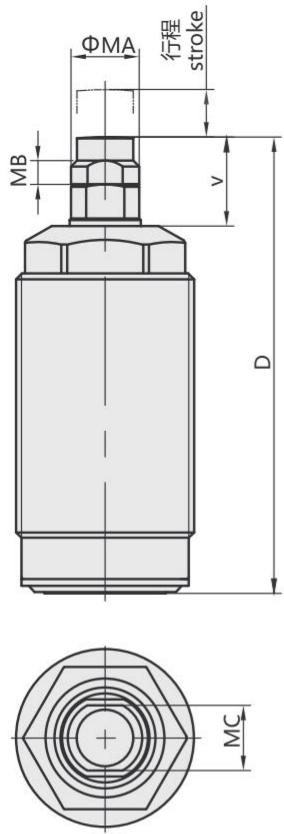

CSP-□M弹簧上顶型  
气检支撑缸外形尺寸图

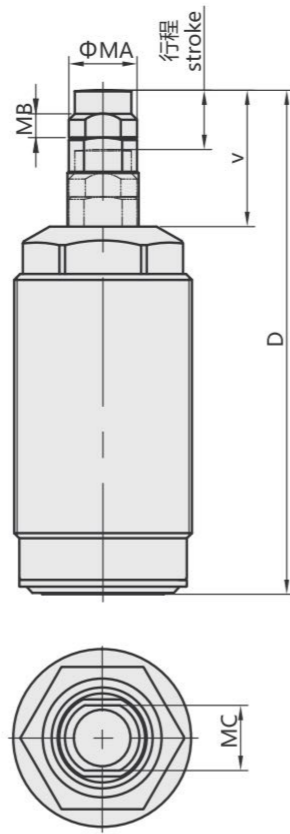

注:其他外形尺寸与非气检支撑缸一致

气检帽盖详图

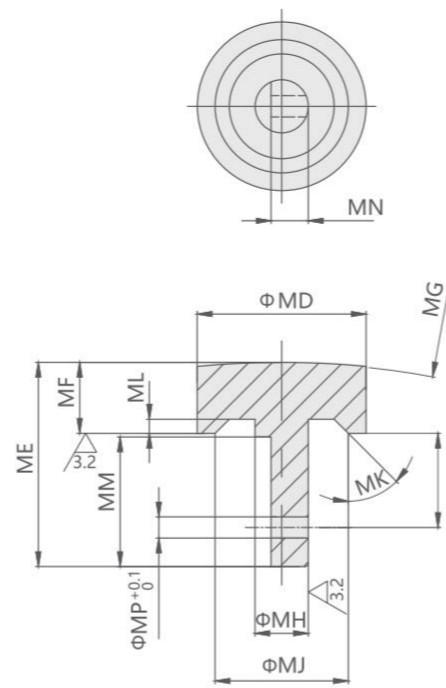

CSP-DF配管底座

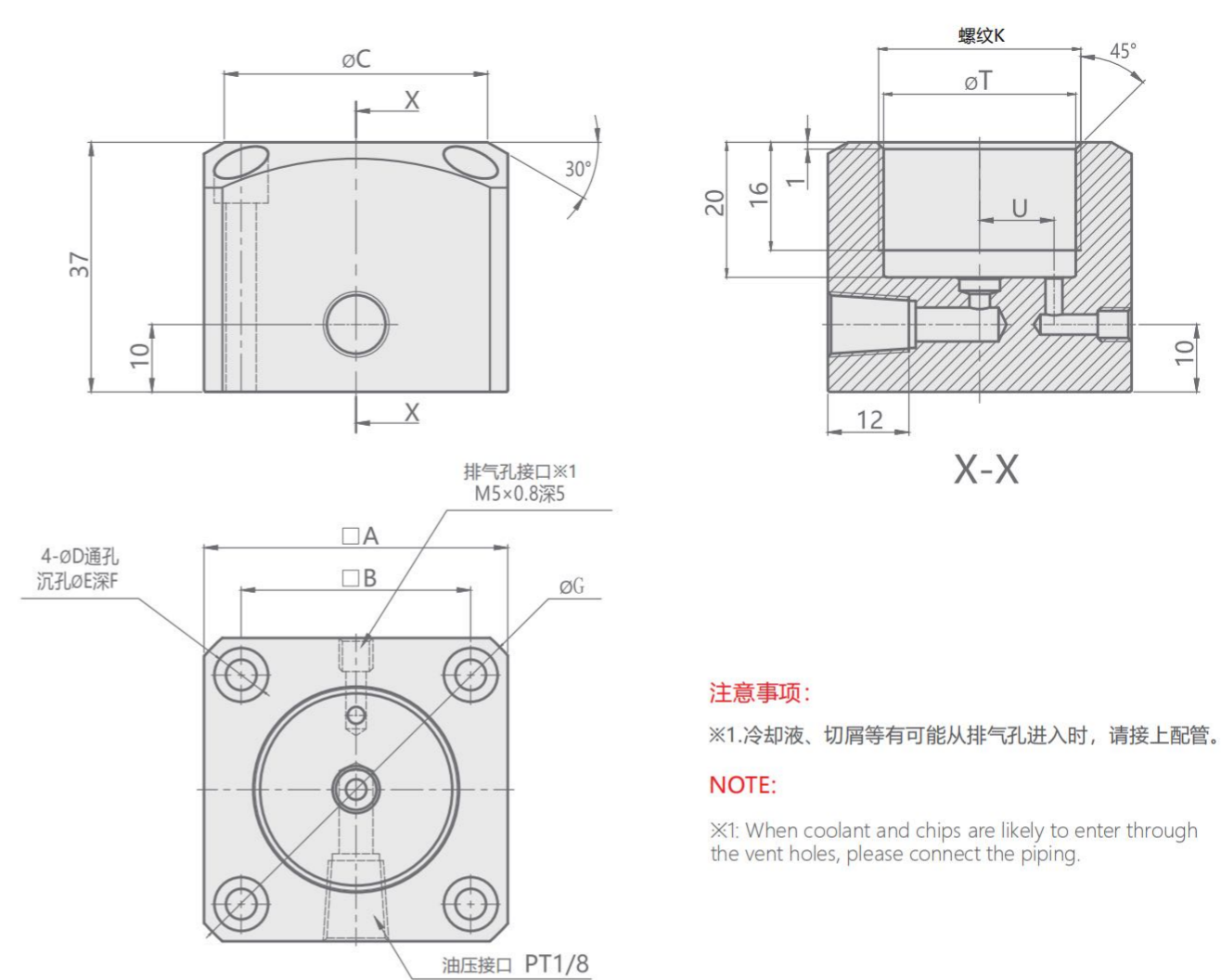

**注意事项:**

※1.冷却液、切屑等有可能从排气孔进入时,请接上配管。

**NOTE:**

※1: When coolant and chips are likely to enter through the vent holes, please connect the piping.

CSP-□M油压气检支撑缸外形尺寸及气检帽盖尺寸

Unit:mm

型号 Model No	CSP-26□M	CSP-30□M	CSP-36□M	CSP-45□M
行程stroke	6.5	8	8	10
D	CSP-□A□M	75.5	85	81
	CSP-□B□M	69	77	73
V	CSP-□A□M	18.5	23	23
	CSP-□B□M	12	15	15
MA	9	11.5	12.5	12.5
MB	3	4	4	4
MC	8	10	11	11
MD	8	9.5	10.5	10.5
ME	12.5	11.5	11.5	11.5
MF	3	4	4	4
MG	SR30	SR30	SR50	SR50
MH	2.5g7	3g7	4g7	5g7
MJ	6	7.5	8.5	8.5
MK	20°	45°	45°	45°
ML	0.8	0.8	0.8	0.8
MM	9.3	7.3	7.3	7.3
MN	1.7	2.1	3.2	3.2
MP	1.4	1.2	1.2	1.2
MQ	7.5	5.3	5.3	5.3

**注意事项:** 1.气检回路推荐气压0.03~0.15MPa, 推荐使用SMC的ISA2-G、ISA3-G空气传感器;  
2.因气检气压或拆卸工件等原因导致支撑杆退回动作迟缓时,可以在支撑杆退回动作中暂时切断气路供给。

CSP-DF油压支撑缸配管式安装座尺寸表

Unit:mm

型号 Model No	CSP-26DF	CSP-30DF	CSP-36DF	CSP-45DF
A	40	45	51	60
B	29	34	38	47
ØC	34	39	45	54
ØD	4.5	4.5	5.5	5.5
ØE	8	8	9	9
F	9	9	12	12
ØG	54	60	68	80
K(公称直径X螺距)	M26X1.5	M30X1.5	M36X1.5	M45X1.5
ØT	24.5	28.5	34.5	43.5
U	9	11	13	16

# YX

## 支撑缸伸缩底座

## YX SUPPORT CYLINDERS TELESCOPIC BASE



### 产品特性

此型式油缸结构紧凑，设计合理，当支撑缸对不同厚薄工件支撑工作时，可采用伸缩底座，避免出现干涉。

### FEATURES

This series product has a compact structure and a reasonable design. When the support cylinder processes workpieces of different thicknesses, an extendable base can be used to avoid interference.

### 规格参数表 SPECIFICATIONS

类型 Type	YX-26	YX-30	YX-36	YX-45
使用力范围 Range of pressure (kgf/cm <sup>2</sup> )	5~140kg/cm <sup>2</sup>			
使用流量 Fluid	已滤清之标准液压油 Filtered oil			
作动方式 Acting type	复动式 Double acting			
标准行程 Standard stroke	请参考尺寸表 Refer to the dimension table			

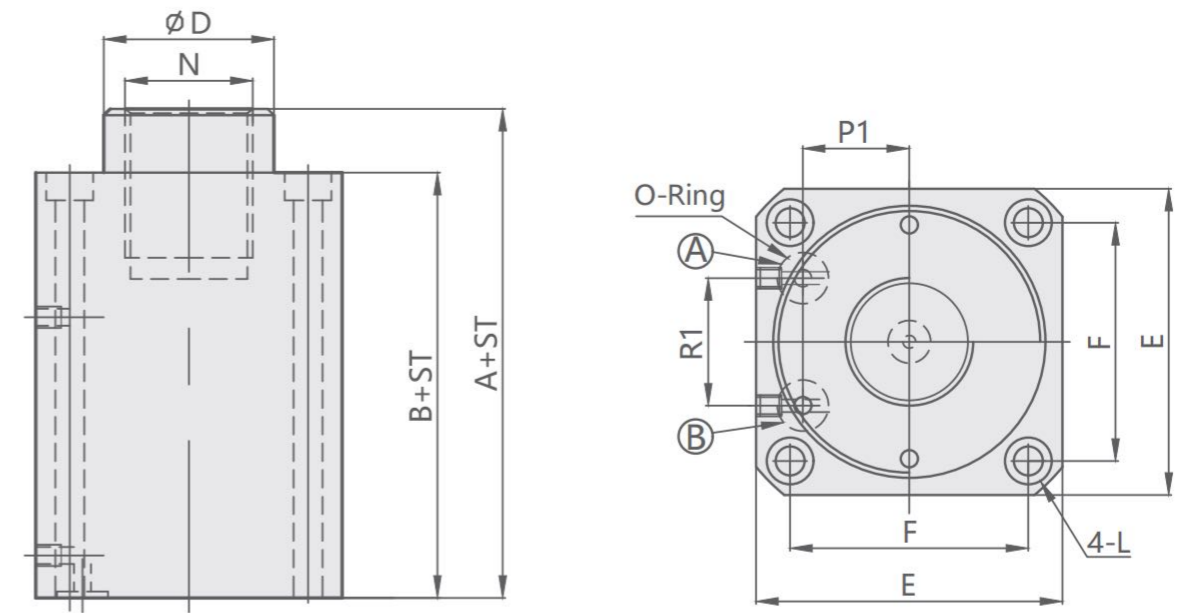

Ⓐ 夹持油孔 Clamping port	Ⓑ 放松油孔 Unclamping port
-------------------------	---------------------------

### 外形尺寸表 DIMENSION TABLE

型号 MODEL	YX-26	YX-30	YX-36	YX-45
A	70	60	60	65
B	55	45	45	50
ØD	40	42	42	53
E	□72	□72	□72	□85
F	□56	□56	□56	□69
L	Ø6.8-Ø11x7D	Ø6.8-Ø11x7D	Ø6.8-Ø11x7D	Ø6.8-Ø11x7D
P1	25	25	25	32
R1	30	30	30	35
N	M26x1.5x30D	M30x1.5x37D	M36x1.5x37D	M45x1.5x38D
O-Ring	P9	P9	P9	P9

CSF

上法兰油压支撑缸

CSF HYDRAULIC  
SUPPORT CLAMP

## 产品特性

- ★高支撑力:提高了活塞杆与夹套间的夹紧力,从而产生更高的工件支撑力。
- ★切削液清洁对策:为防止高压冷却液及切屑粉尘侵入内部结构而引发的作动不良,更换工件时可在排气孔进行空气清洁。空气清洁需要专用的气压回路。(建议清洁气压0.3~0.5MPa)

## 液压上升型:

活塞杆初始状态为下降,供给油压使活塞杆上升并接触工件任意位置后停止,在停止的同时油压作用于夹套的夹紧力施加于活塞杆,使活塞杆得以稳固的支撑工件。

## 弹簧上升型:

活塞杆初始状态为上升,将工件放置于活塞杆上因工件的重量而下降到特定距离,此时供给油压作用于夹套的夹紧力施加于活塞杆,使活塞杆得以稳固的支撑工件。

## 订购标示法 ORDERING INDICATION

## 示例: CSF-040BLGQ

CSF	系列 Series	CSF		
040	主体尺寸 Body diameter	040=∅40mm 048=∅48mm	055=∅55mm 065=∅65mm	075=∅75mm 090=∅90mm
B	型式 Type	A:弹簧上升型 B:液压上升型(标准) D:中空型	A:Spring rising type B:Hydraulic rising type (standard) D:Hollow type	 液压上升型  弹簧上升型
L	压强 Pressure	低压7MPa	Low pressure 7MPa	
G	配管方式 Type	G:油路板式(配有G螺纹堵头) S:配管式(PT螺纹)	G: Manifold type ( with G thread plug) S: Line type ( PT thread)	
Q	行程 Stroke	空白: 标准行程 Q: 加长行程	Blank: Standard stroke Q: Extended stroke	

## FEATURES

**High Supporting Force:** The gap between the plunger and the collet is expanded to improve its overall performance, resulting in a higher supporting force. To prevent improper operation caused by high-pressure coolant and chip dust from entering the internal structure, air cleaning can be performed in the exhaust hole when replacing the workpiece. Air cleaning requires a specific air pressure circuit (recommended cleaning air pressure at 0.3~0.5MPa).

## Hydraulic Pressure Rising Type:

The initial state of the piston rod is down. When the oil pressure is supplied, the piston rod rises and stops once contact is made with the workpiece at any position. During this period, the hydraulic pressure on the collet can grip the plunger with stronger power to generate the supporting force.

## Spring Rising Type:

The initial state of the piston rod is up, and the workpiece is placed on the piston rod and dropped to a certain distance due to the weight of the workpiece. During this period, the hydraulic pressure on the collet can grip the plunger with stronger power to generate the supporting force.

## 支撑力曲线图

\*本图表示静态负荷条件下的支撑力。

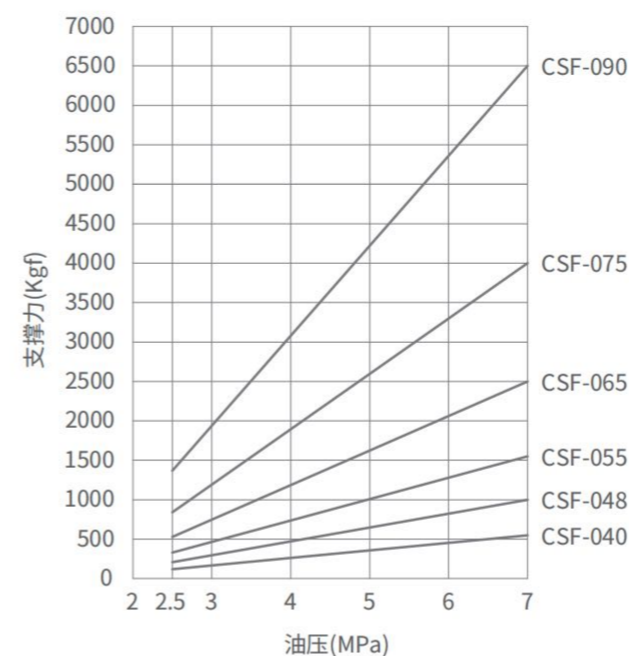

## 负荷/变位量曲线图

\*本图表示供给油压在7Mpa条件下的静态负荷下的变化

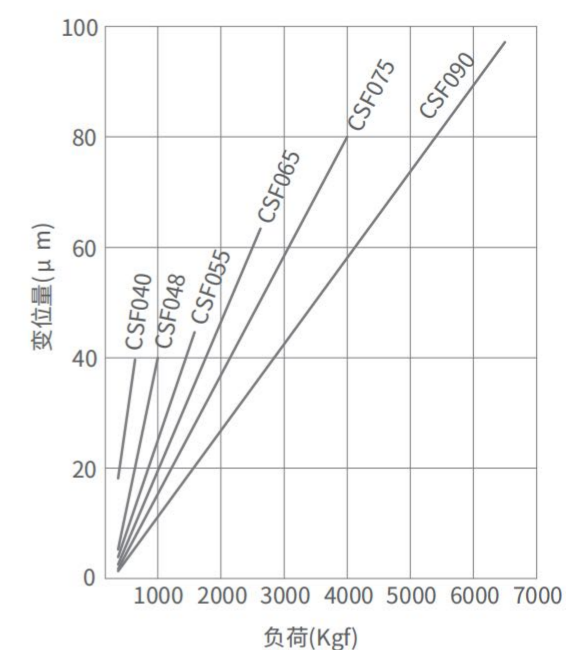

## 规格参数表 SPECIFICATIONS

型号	工作支撑力 (油压7MPa时)	油缸容量	上升弹簧力	活塞杆行程	最高使用压力	最低使用压力	保证耐压	使用温度	质量
MODEL	WORKPIECE SUPPORT FORCE (WHEN OIL PRESSURE IS 7MPa) (kgf)	OIL CYLINDER CAPACITY (cm <sup>3</sup> )	RISING SPRING FORCE (kgf)	PISTON ROD STROKE (mm)	MAXIMUM WORKING PRESSURE (MPa)	MINIMUM WORKING PRESSURE (MPa)	ENSURE OVERPRESSURE -RESISTANT (MPa)	OPERATING TEMPERATURE (°C)	Quality (kg)
CSF-040	550	1.2	0.5~0.8	8	7	2.5	10.5	0~70	0.6
CSF-048	1000	2.0	0.5~1.4	10	7	2.5	10.5	0~70	0.9
CSF-055	1550	3.3	1.2~1.8	12	7	2.5	10.5	0~70	1.4
CSF-065	2500	4.8	1.4~2.5	14	7	2.5	10.5	0~70	2.2
CSF-075	4000	8.9	2.3~3.3	16	7	2.5	10.5	0~70	3.6
CSF-090	6500	13.1	2.5~4.0	20	7	2.5	10.5	0~70	6

使用流体:普通矿物油基液压油(相当于ISO-VG32)

※1:将支撑缸与夹套缸对置使用时,为了使支撑力足够所使用的支撑缸支撑力应该为夹套缸与切削负荷的1.5倍以上请选择型号匹配的支撑缸与夹套缸。

※2:活塞杆上升弹簧力的数值表示弹簧设计值。该值会因活塞杆的滑动阻力、弹簧特性等而产生一定的偏差,所以上升弹簧力为参考值。

Recommended: ISO-VG-32 hydraulic oil equivalent to ISO viscosity grade

※1: When the support clamp and cylinder damp are used opposite from each other, the supporting force must be 1.5 times the amount of the damping force and cutting load in order for the support clamp to work sufficiently. Please check the compatibility of the support clamp and cylinder damp when selecting parts.

※2: The plunger spring force indicates the spring design value. It may vary depending on sliding resistance of the plunger and characteristic of the spring, etc. Please use the rising spring force as a reference value.

### 外形尺寸

※本图表示为CSF-G型初始状态

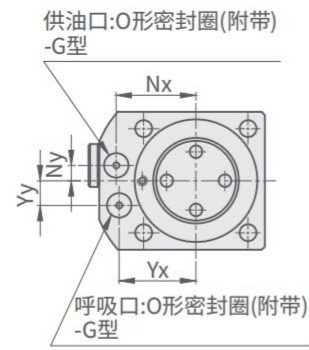

### 接触螺栓设计尺寸

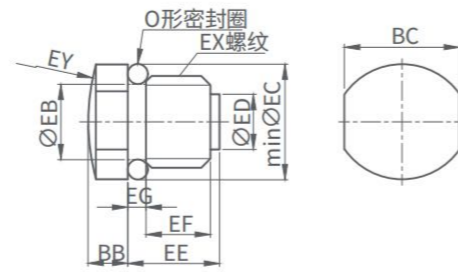

### CSF-A型 弹簧上升型

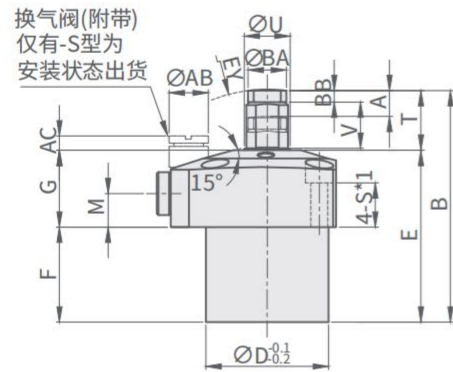

### CSF-B型 液压上升型

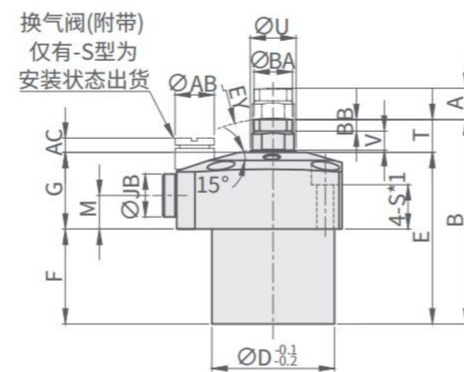

### 安装部位加工尺寸

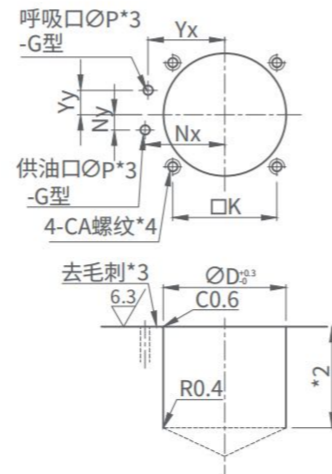
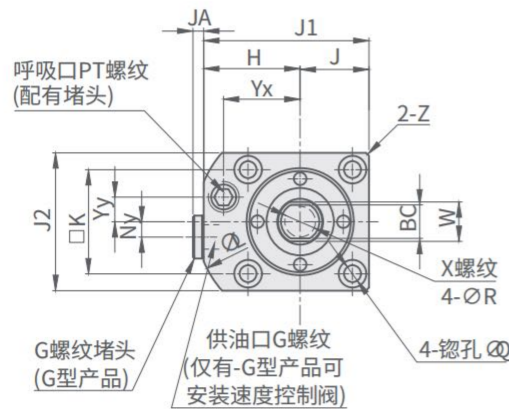

### 注意事项

- ※1.本产品未附带安装螺栓，请客户根据安装高度并参照S尺寸自行配置使用。
- ※2.请参考F尺寸，并根据安装高度决定本体安装孔ØD的深度。
- ※3.本加工表示-G板式连接型的情况。
- ※4.请参考S尺寸，并根据安装高度决定安装螺栓的CA螺纹深度。

### NOTE

- ※1.This product does not come with mounting bolts, please configure according to the installation height and refer to the S-size.
- ※2.Refer to the F dimension and determine the depth of DD of the mounting hole based on the mounting height.
- ※3.This processing represents the case of -G plate connection type.
- ※4.Please refer to the S-dimension and determine the CA thread depth of the mounting bolt according to the mounting height.

### 外形尺寸及安装部位加工尺寸表

Unit:mm

型号Model	CSF-040	CSF-048	CSF-055	CSF-065	CSF-075	CSF-090
A 行程	8	10	12	14	16	20
B	A型: 弹簧上升型	75	85	97	115	169
	B型: 液压上升型	67	75	85	101	149
J1	54	61	69	81	92	107
J2	45	51	60	70	80	95
D	40	48	55	65	75	90
E	56	64	70	85	107	128
F	31	39	45	56	72	88
G	25	25	25	29	35	40
H	31.5	35.5	39	46	52	59.5
J	22.5	25.5	30	35	40	47.5
K	34	40	47	55	63	75
L	68	73	80	94	106	126
M	11	11	11	11	13	13
Nx	26	30	33.5	39.5	45	52.5
Ny	5	0	0	0	0	0
P	3	3	3	5	5	5
Q	9.5	9.5	11	11	14	17.5
R	5.5	5.5	6.8	6.8	9	11
S	14.5	13.5	11.5	14.5	17	18
T	A型: 弹簧上升型	19	21	27	30	41
	B型: 液压上升型	11	11	15	16	19
U	15	16	20	22	25	30
V	6	6	8	9	9	10.5
W	13	13	17	19	22	24
X(标称X深度)	M10X11	M10X11	M12X13	M12X13	M16X20	M16X20
Yx	25	28	31	37	42.5	50
Yy	8	11	13	14	15	15
Z(倒角)	C1	C3	R40	R47	R53	R63
AB	12	12	12	12	12	12
AC	5	4	3.5	2	1.5	0
BA	12.5	12.5	16.5	16.5	21.5	21.5
BB	4	4	6	6	9	9
BC	11	11	14	14	19	19
CA	M5	M5	M6	M6	M8	M10
EY	SR50	SR50	SR80	SR80	SR125	SR125
JA	3.5	3.5	3.5	3.5	4.5	4.5
JB	14	14	14	14	19	19
供油口	-G型	G1/8	G1/8	G1/8	G1/8	G1/4
	-S型	RC1/8	RC1/8	RC1/8	RC1/8	RC1/4
G螺纹堵头 -G型	G1/8	G1/8	G1/8	G1/8	G1/4	G1/4
O型密封圈(G型)	1BP5	1BP5	1BP5	1BP7	1BP7	1BP7
呼吸口PT螺纹	PT1/8	PT1/8	PT1/8	PT1/8	PT1/8	PT1/8

### 接触螺栓设计制作尺寸表

※客户自行设计制作非出厂自带的接触螺栓(配件)时，请参考接触螺栓设计制作尺寸表。

型号	CSF-040	CSF-048	CSF-055	CSF-065	CSF-075	CSF-090
EB	8.2	8.2	10	10	13.5	13.5
EC	12.5	12.5	16.5	16.5	21.5	21.5
ED	6	6	7.5	7.5	10.5	10.5
EE	10	10	12	12	16	16
EF	7	7	8	8	11	11
EG	2	2	3	3	4	4
EX	M10	M10	M12	M12	M16	M16
O型密封圈	S8(NOK制品)	S8(NOK制品)	S10(NOK制品)	S10(NOK制品)	AS568-014(70°)	AS568-014(70°)

### 外形尺寸

\*本图表示为CSF-D中空板式连接型初始状态

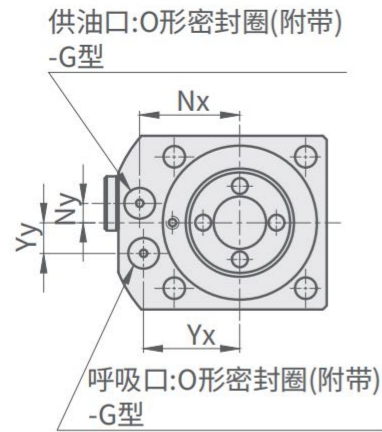

### CSF-D型 中空型

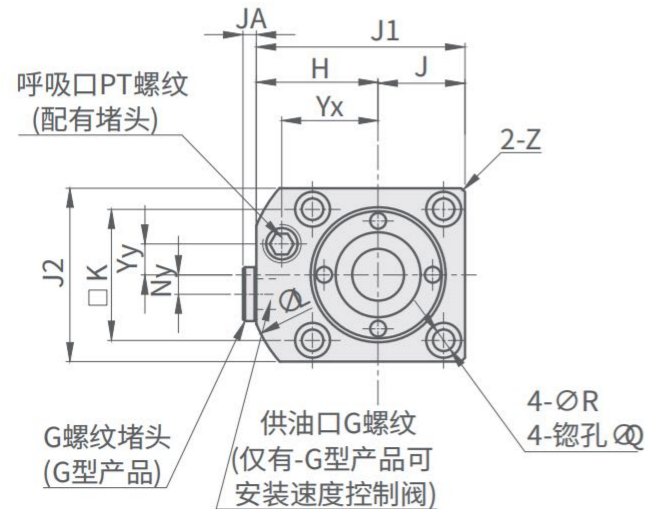
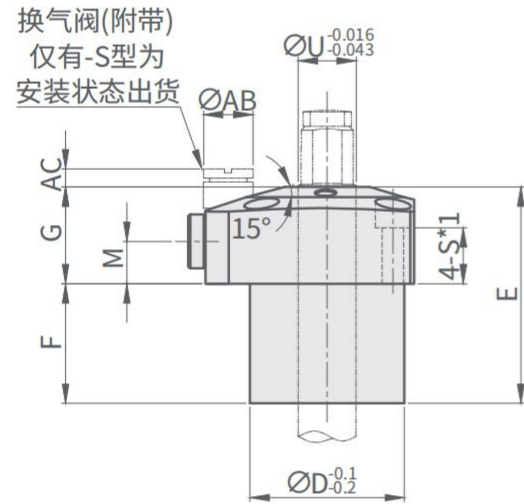

### 安装部位加工尺寸

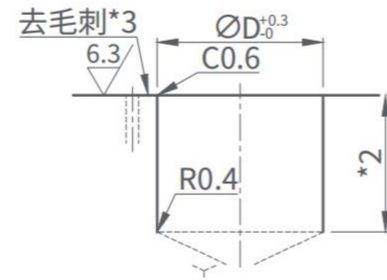
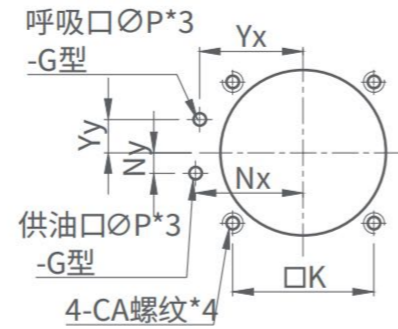

### 注意事项

- ※1.本产品未附带安装螺栓，请客户根据安装高度并参照S尺寸自行配置使用。
- ※2.请参考F尺寸，并根据安装高度决定本体安装孔ΦD的深度。
- ※3.本加工表示-G板式型的情况。
- ※4.请参考S尺寸，并根据安装高度决定安装螺栓的CA螺纹深度。

### NOTE

- ※1.This product does not come with mounting bolts, please configure according to the installation height and refer to the S-size.
- ※2.Refer to the F dimension and determine the depth of DD of the mounting hole based on the mounting height.
- ※3.This processing presents the case of -G plate connection type.
- ※4.Please refer to the S-dimension and determine the CA thread depth of the mounting bolt according to the mounting height.

### 外形尺寸及安装部位加工尺寸表

Unit:mm

型号Model	CSF-040-D	CSF-048-D	CSF-055-D	CSF-065-D	CSF-075-D	CSF-090-D
J1	54	61	69	81	92	107
J2	45	51	60	70	80	95
D	40	48	55	65	75	90
E	56	64	70	85	107	128
F	31	39	45	56	72	88
G	25	25	25	29	35	40
H	31.5	35.5	39	46	52	59.5
J	22.5	25.5	30	35	40	47.5
K	34	40	47	55	63	75
L	68	73	80	94	106	126
M	11	11	11	11	13	13
Nx	26	30	33.5	39.5	45	52.5
Ny	5	0	0	0	0	0
P	3	3	3	5	5	5
Q	9.5	9.5	11	11	14	17.5
R	5.5	5.5	6.8	6.8	9	11
S	14.5	13.5	11.5	14.5	17	18
U	15	16	20	22	25	30
Yx	25	28	31	37	42.5	50
Yy	8	11	13	14	15	15
Z(倒角)	C1	C3	R40	R47	R53	R63
AB	12	12	12	12	12	12
AC	5	4	3.5	2	1.5	0
CA	M5	M5	M6	M6	M8	M10
JA	3.5	3.5	3.5	3.5	4.5	4.5
JB	14	14	14	14	19	19
供油口	-G型 G1/8	G1/8	G1/8	G1/8	G1/4	G1/4
	-S型 RC1/8	RC1/8	RC1/8	RC1/8	RC1/4	RC1/4
G螺纹堵头	-G型 G1/8	G1/8	G1/8	G1/8	G1/4	G1/4
O型密封圈(G型)	1BP5	1BP5	1BP5	1BP7	1BP7	1BP7
呼吸口PT螺纹	PT1/8	PT1/8	PT1/8	PT1/8	PT1/8	PT1/8

## 外形尺寸

\*本图表示为CSF-Q加长型板式连接型初始状态

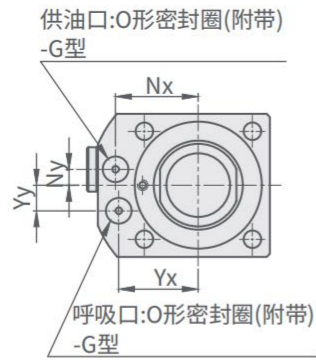

CSF-Q A型 弹簧上升型

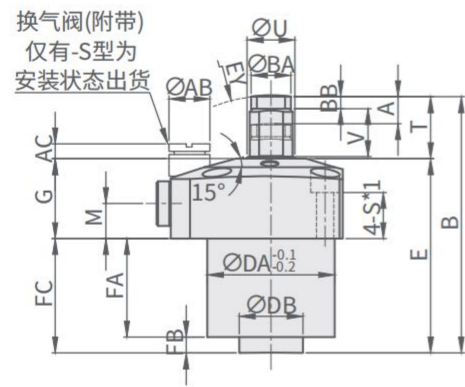

CSF-Q B型 液压上升型

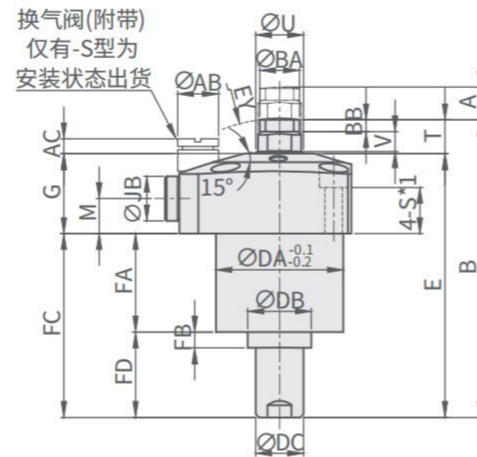

安装部位加工尺寸

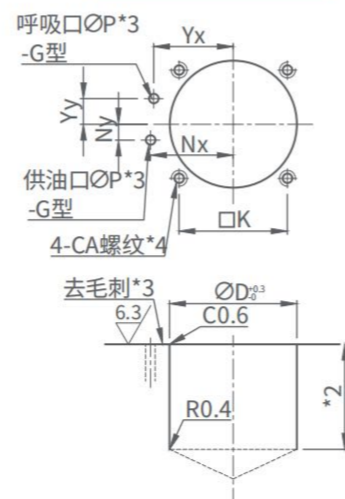
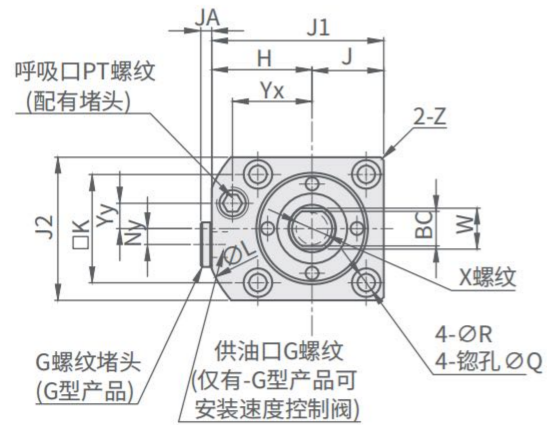

### 注意事项

- ※1.本产品未附带安装螺栓，请客户根据安装高度并参照S尺寸自行配置使用。
- ※2.请参考F尺寸，并根据安装高度决定本体安装孔ΦD的深度。
- ※3.本加工表示-G板式连接型的情况。
- ※4.请参考S尺寸，并根据安装高度决定安装螺栓的CA螺纹深度。

### NOTE

- ※1.This product does not come with mounting bolts, please configure according to the installation height and refer to the S-size.
- ※2.Refer to the F dimension and determine the depth of ΦD of the mounting hole based on the mounting height.
- ※3.This processing represents the case of -G plate connection type.
- ※4.Please refer to the S-dimension and determine the CA thread depth of the mounting bolt according to the mounting height.

## 外形尺寸及安装部位加工尺寸表

Unit:mm

型号Model		CSF-040-Q	CSF-048-Q	CSF-055-Q	CSF-065-Q	CSF-075-Q	CSF-090-Q
A	行程	16	20	24	28	32	40
B	A型: 弹簧上升型	83	98.5	114.5	138.5	170	203.5
	B型: 液压上升型	95	112	131.5	149.5	177.5	212
J1		54	61	69	81	92	107
J2		45	51	60	70	80	95
DA		40	48	55	65	75	90
DB		0	0	33	36	42	52
DC		19	19	23	23	30	30
E		84	101	116.5	133.5	158.5	191
FA		31	39	45	56	72	88
FB		0	0	3	5	10	14
FC		59	76	91.5	104.5	123.5	151
FD		28	37	46.5	48.5	51.5	63
G		25	25	25	29	35	40
H		31.5	35.5	39	46	52	59.5
J		22.5	25.5	30	35	40	47.5
K		34	40	47	55	63	75
L		68	73	80	94	106	126
M		11	11	11	11	13	13
Nx		26	30	33.5	39.5	45	52.5
Ny		5	0	0	0	0	0
P		3	3	3	5	5	5
Q		9.5	9.5	11	11	14	17.5
R		5.5	5.5	6.8	6.8	9	11
S		14.5	13.5	11.5	14.5	17	18
T	A型: 弹簧上升型	27	31	39	44	51	61
	B型: 液压上升型	11	11	15	16	19	21
U		15	16	20	22	25	30
V		6	6	8	9	9	10.5
W		13	13	17	19	22	24
X(标称X深度)		M10X11	M10X11	M12X13	M12X13	M16X20	M16X20
Yx		25	28	31	37	42.5	50
Yy		8	11	13	14	15	15
Z(倒角)		C1	C3	R40	R47	R53	R63
AB		12	12	12	12	12	12
AC		5	4	3.5	2	1.5	0
BA		12.5	12.5	16.5	16.5	21.5	21.5
BB		4	4	6	6	9	9
BC		11	11	14	14	19	19
CA		M5	M5	M6	M6	M8	M10
EY		SR50	SR50	SR80	SR80	SR125	SR125
JA		3.5	3.5	3.5	3.5	4.5	4.5
JB		14	14	14	14	19	19
供油口	-G型	G1/8	G1/8	G1/8	G1/8	G1/4	G1/4
	-S型	RC1/8	RC1/8	RC1/8	RC1/8	RC1/4	RC1/4
G螺纹堵头	-G型	G1/8	G1/8	G1/8	G1/8	G1/4	G1/4
O型密封圈(G型)		1BP5	1BP5	1BP5	1BP7	1BP7	1BP7
呼吸口PT螺纹		PT1/8	PT1/8	PT1/8	PT1/8	PT1/8	PT1/8

# CSF-P

## 上法兰油压支撑缸

## CSF-P HYDRAULIC SUPPORT CLAMP



### 产品特性

- ★高支撑力:提高了活塞杆与夹套间的夹紧力,从而产生更高的工件支撑力。
- ★切削液清洁对策:为防止高压冷却液及切屑粉尘侵入内部结构而引发的作动不良,更换工件时可在排气孔进行空气清洁。空气清洁需要专用的气压回路。(建议清洁气压0.3~0.5MPa)

### 液压上升型:

活塞杆初始状态为下降,供给油压使活塞杆上升并接触工件任意位置后停止,在停止的同时油压作用于夹套的夹紧力施加于活塞杆,使活塞杆得以稳固的支撑工件。

### 弹簧上升型:

活塞杆初始状态为上升,将工件放置于活塞杆上因工件的重量而下降到特定距离,此时供给油压作用于夹套的夹紧力施加于活塞杆,使活塞杆得以稳固的支撑工件。

### 订购标示法 ORDERING INDICATION

#### 示例: CSF-052BLP

CSF	系列 Series	CSF		
052	主体尺寸 Body diameter	040=∅40mm 060=∅60mm	047=∅47mm 072=∅72mm	052=∅52mm
B	型式 Type	A:弹簧上升型 B:液压上升型(标准)	A:弹簧上升型 B:液压上升型	A:Spring rising type B:Hydraulic rising type
L	压强 Pressure	低压7MPa	Low pressure 7MPa	
P	版本 Version	P		

### FEATURES

**High Supporting Force:** The gap between the plunger and the collet is expanded to improve its overall performance, resulting in a higher supporting force. To prevent improper operation caused by high-pressure coolant and chip dust from entering the internal structure, air cleaning can be performed in the exhaust hole when replacing the workpiece. Air cleaning requires a specific air pressure circuit (recommended cleaning air pressure at 0.3~0.5MPa).

### Hydraulic Pressure Rising Type:

The initial state of the piston rod is down. When the oil pressure is supplied, the piston rod rises and stops once contact is made with the workpiece at any position. During this period, the hydraulic pressure on the collet can grip the plunger with stronger power to generate the supporting force.

### Spring Rising Type:

The initial state of the piston rod is up, and the workpiece is placed on the piston rod and dropped to a certain distance due to the weight of the workpiece. During this period, the hydraulic pressure on the collet can grip the plunger with stronger power to generate the supporting force.

### 支撑力曲线图

\*本图表示静态负荷条件下的支撑力。

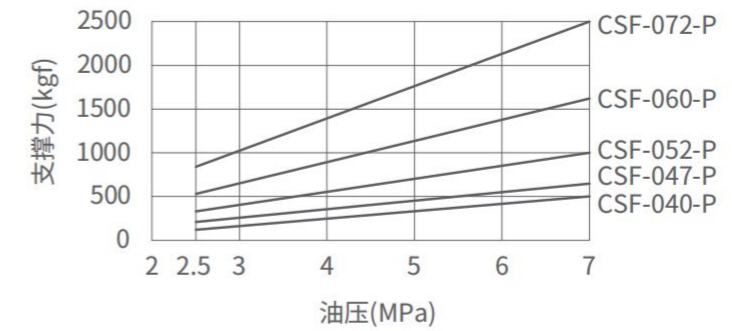

### 负荷/变位量曲线图

\*本图表示供给油压在7Mpa条件下的静态负荷下的变化

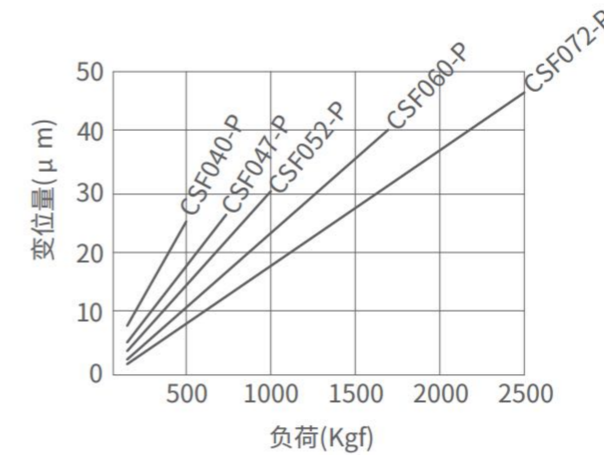

### 规格参数表 SPECIFICATIONS

型号	工作支撑力 (油压7MPa时)	油缸容量	上升弹簧力	活塞杆行程	最高使用压力	最低使用压力	保证耐压	使用温度	质量
MODEL	WORKPIECE SUPPORT FORCE (WHEN OIL PRESSURE IS 7MPa) (kgf)	OIL CYLINDER CAPACITY (cm <sup>3</sup> )	RISING SPRING FORCE (kgf)	PISTON ROD STROKE (mm)	MAXIMUM WORKING PRESSURE (MPa)	MINIMUM WORKING PRESSURE (MPa)	ENSURE OVERPRESSURE -RESISTANT (MPa)	OPERATING TEMPERATURE (°C)	Quality (kg)
CSF-040-P	500	0.7	3.0~4.1	8	7	2.5	10.5	0~70	0.6
CSF-047-P	700	0.9	4.3~8.1	12	7	2.5	10.5	0~70	1.0
CSF-052-P	1000	1.2	5.3~10.8	12	7	2.5	10.5	0~70	1.2
CSF-060-P	1600	2.1	5.5~10.8	16	7	2.5	10.5	0~70	2.0
CSF-072-P	2500	3.3	6.9~13.2	16	7	2.5	10.5	0~70	3.3

## 外形尺寸

※本图表示为CSF-P式油路板型初始状态

### CSF-P A型 弹簧上升型

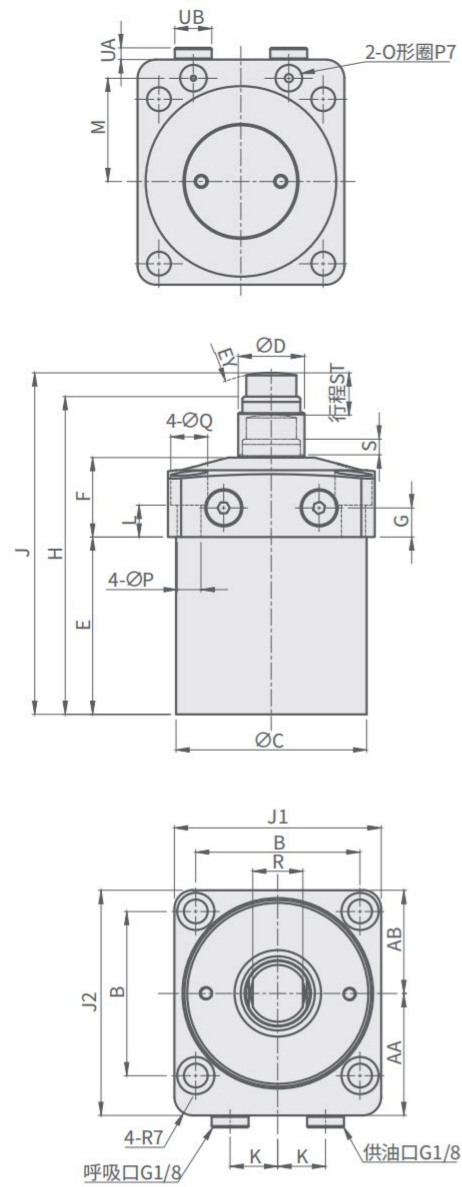

### CSF-P B型 液压上升型

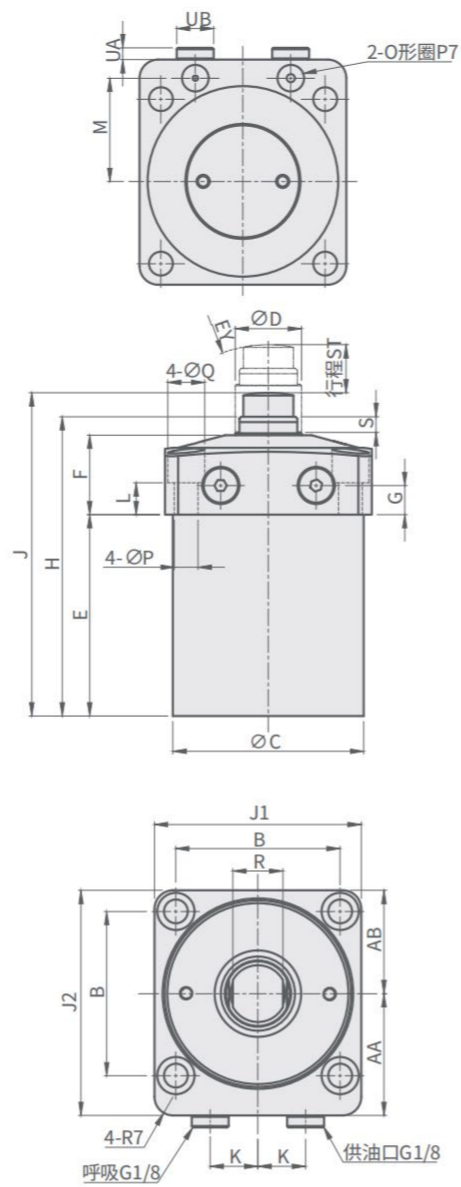

### 接触螺栓设计尺寸

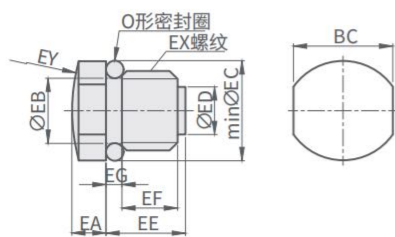

### 安装部位加工尺寸

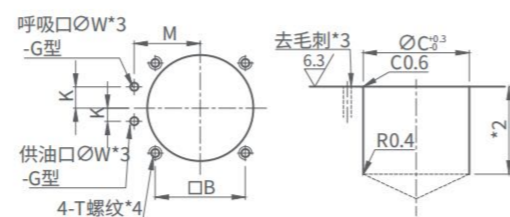

### 注意事项

- ※1.本产品未附带安装螺栓，请客户根据安装高度并参照L尺寸自行配置使用。
- ※2.请参考F尺寸，并根据安装高度决定本体安装孔ΦD的深度。
- ※3.本加工表示-G板式连接型的情况。
- ※4.请参考S尺寸，并根据安装高度决定安装螺栓的CA螺纹深度。

### NOTE

- ※1.This product does not come with mounting bolts, please configure according to the installation height and refer to the L-size.
- ※2.Refer to the F dimension and determine the depth of ΦD of the mounting hole based on the mounting height.
- ※3.This processing represents the case of -G plate connection type.
- ※4.Please refer to the S-dimension and determine the CA thread depth of the mounting bolt according to the mounting height.

## 外形尺寸及安装部位加工尺寸表

Unit:mm

型号Model	CSF-040-P	CSF-047-P	CSF-052-P	CSF-060-P	CSF-072-P	
ST	8	12	12	16	16	
J1	45	52	56	65	78	
J2	55	61	65	73	85	
AA	32.5	35	37	40.5	46	
AB	22.5	26	28	32.5	39	
B	34	40	44	52	62	
C	40	47	52	60	72	
D	15	16	20	22	25	
E	A型: 弹簧上升型	21	32	33	47	67
	B型: 液压上升型	30	41	42	57	76
F	26	26	28	30	30	
G	A型: 弹簧上升型	11	11	11	11	11
	B型: 液压上升型	60	75	78	99	120
H	A型: 弹簧上升型	61	72	75	93	113
	B型: 液压上升型	67	82	85	108	129
J	A型: 弹簧上升型	68	79	82	102	122
	B型: 液压上升型	10	12	13	15	18
K	10	12	13	15	18	
L	15	15	16.5	15.9	12	
M	25.5	28	30	33.5	39	
P	5.5	5.5	5.5	6.8	9	
Q	9.5	9.5	9.5	11	14	
R	13	13	17	19	22	
S	4	4	4.5	5	6	
T	M5	M5	M6	M6	M8	
EY	SR50	SR50	SR80	SR80	SR125	
UA	3.5	3.5	3.5	3.5	4.5	
UB	14	14	14	14	19	
W	3	3	3	3	3	
供油口	-G型 油路板型	G1/8	G1/8	G1/8	G1/8	G1/8
G螺纹堵头	-G型	G1/8	G1/8	G1/8	G1/8	G1/8
O形密封圈(G型)	1BP7	1BP7	1BP7	1BP7	1BP7	
呼吸口 G螺纹	G1/8	G1/8	G1/8	G1/8	G1/8	

### 接触螺栓设计制作尺寸表

※客户自行设计制作非出厂自带的接触螺栓(配件)时，请参考接触螺栓设计制作尺寸表。

型号	CSF-040-P	CSF-047-P	CSF-052-P	CSF-060-P	CSF-072-P
EA	4	4	6	6	9
EB	8.2	8.2	10	10	13.5
EC	12.5	12.5	16.5	16.5	21.5
ED	6	6	7.5	7.5	10.5
EE	10	10	12	12	16
EF	7	7	8	8	11
EG	2	2	3	3	4
EX	M10	M10	M12	M12	M16
O型密封圈	S8(NOK制品)	S8(NOK制品)	S10(NOK制品)	S10(NOK制品)	AS568-014(70°)

# CTNC

## 高压支撑缸

### CTNC HIGH PRESSURE HYDRAULIC SUPPORT CLAMP



#### 产品特性

- ★高支撑力：改进夹套与支撑杆的结构，产生更高的工件支撑力。
- ★高耐压：使用压力范围为7~35MPa。
- ★通用的安装底座：与目前市售的日系缸拥有相同规格，具有互换性。

#### 液压上升型：

支撑杆初始位置为下降，供给油压使支撑杆上升并接触工件后停止，同时供给油压作用于夹套的加紧力施加于支撑杆，使支撑杆稳固的支撑工件

#### 弹簧上升型：

支撑杆初始位置为上升，放上工件，支撑杆就会因工件重量而下降到设定位置，然后在供给油压作用夹套的加紧力施加于支撑杆，使支撑杆稳固的支撑工件

#### FEATURES

- ★High Supporting Force: The gap between the plunger and the collet is expanded to improve its overall performance, resulting in a higher supporting force.
- ★High pressure: The range of working pressure is 7 ~ 35MPa.
- ★Universal mounting base: The CTNC series is compatible and interchangeable with Japanese branded cylinders that are currently on the market.

#### Hydraulic Pressure Rising Type:

The initial state of the piston rod is down. When the oil pressure is supplied, the piston rod rises and stops once contact is made with the workpiece at any position. During this period, the hydraulic pressure on the collet can grip the plunger with stronger power to generate the supporting force.

#### Spring Rising Type:

The initial state of the piston rod is up, and the workpiece is placed on the piston rod and dropped to a certain distance due to the weight of the workpiece. During this period, the hydraulic pressure on the collet can grip the plunger with stronger power to generate the supporting force.

#### 订购标示法 ORDERING INDICATION

##### 示例：CTNC-30B

CTNC	系列 Series	CTNC
30	油缸外径 Hydraulic cylinder outside diameter	M26*1.5 ,M30*1.5,M36*1.5,M45*1.5
B	型式 Type	A: 弹簧上升型 A:Spring rising type B: 液压上升型 B:Hydraulic rising type

#### 油压与支撑力的关系

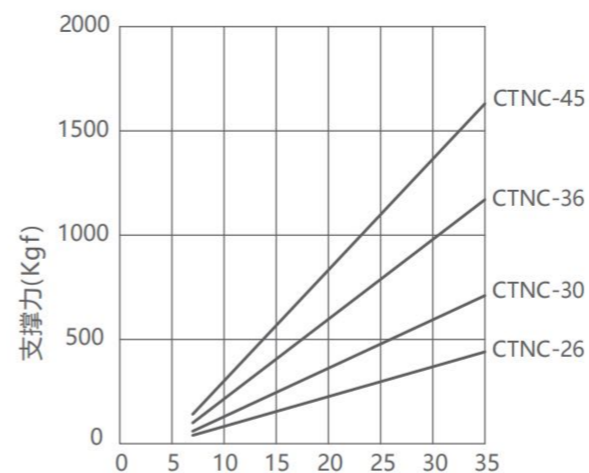

#### 供给油压(MPa)

本图表示静态负荷条件下的支撑力

#### 负荷与变位量的关系

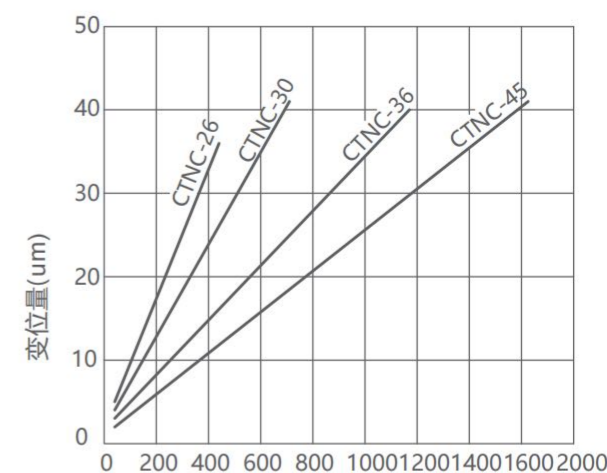

#### 负荷(Kgf)

本图表示供给油压35MPa条件下静态负荷变位量

#### 规格参数表 SPECIFICATIONS

型号	支撑力 (油压35MPa时)	油缸容量	上升弹簧力	支撑杆行程	最高使用压力	最低使用压力	使用温度	质量
MODEL	WORKPIECE SUPPORT FORCE WHEN OIL PRESSURE IS 35MPa(kgf)	OIL CYLINDER CAPACITY(cm <sup>3</sup> )	RISING SPRING FORCE(N)	STROKE FOR SUPPORT ROD(mm)	MAX. WORKING PRESSURE(MPa)	MIN. WORKING PRESSURE(MPa)	OPERATING TEMPERATURE(°C)	QUALITY(Kg)
CTNC-26	440	0.3	4~8	6.5	35	7	0~70°C	0.15
CTNC-30	710	0.6	5~11	8	35	7	0~70°C	0.2
CTNC-36	1170	1.1	6~14	10	35	7	0~70°C	0.3
CTNC-45	1630	1.8	8~22	12	35	7	0~70°C	0.75

#### 注意事项

- 1.当支撑缸与夹紧缸对置使用时，选型时一定要注意，所选支撑缸支撑力应大于夹紧缸夹紧力的1.5倍以上。
- 2.自制帽盖时请参照帽盖详图尺寸，且需考虑帽盖的重量及弹簧力，否则会出现支撑缸动作不良的现象。
- 3.保持通过排气口供气，可有效的防止切削液、切削粉尘等侵入支撑缸内部。
- 4.如果支撑杆上升速度过快，在支撑杆接触工件时会产生反弹并在弹回位置被夹紧，造成支撑杆与工件之间出现间隙。防止出现这种情况请使用进油节流的流量阀进行调节，使支撑杆上升动作时间在0.5~1秒左右，确认支撑缸与工件没有间隙后再投入使用。

#### NOTE

- 1.When the support clamp and cylinder clamp are used opposite from each other, pay attention to the selection, the supporting force should be more than 1.5 times of the cylinder clamping force.
- 2.Please refer to the cap detailed drawing when the user makes the cap, and consider the weight of the cap and the spring force, otherwise there will be poor operation of the support cylinder.
- 3.Keep the vent hole open to the atmosphere, which can effectively prevent cutting fluid and cutting dust from invading the inside of the support cylinder.
- 4.If the piston rod rising speed is too fast, it will cause the phenomenon of rebound when the piston rod contacts the workpiece, and clamp at the rebound position, which will cause the gap or impact between the piston rod and the workpiece, leading to the damage of the internal parts. Please adjust the rising speed of the piston rod through one-way flow control valve so that the rising action time is more than 0.5-1 second, and confirm that there is no gap and impact between the piston rod and workpiece before putting into use.

## 外形尺寸

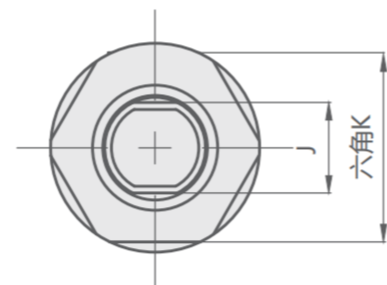
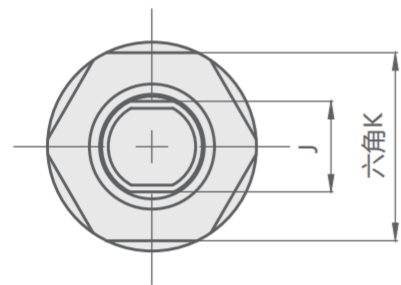
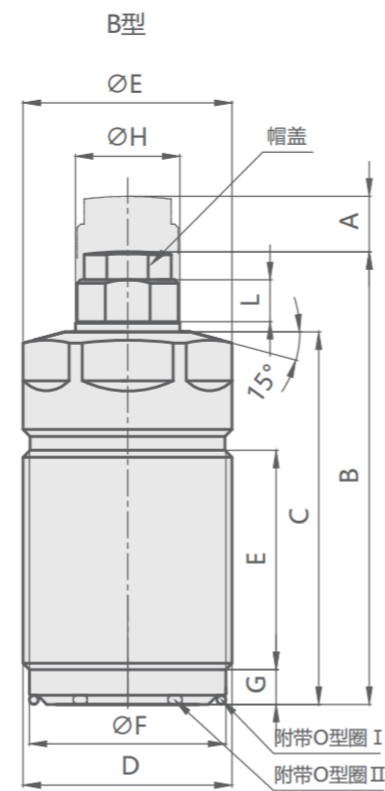
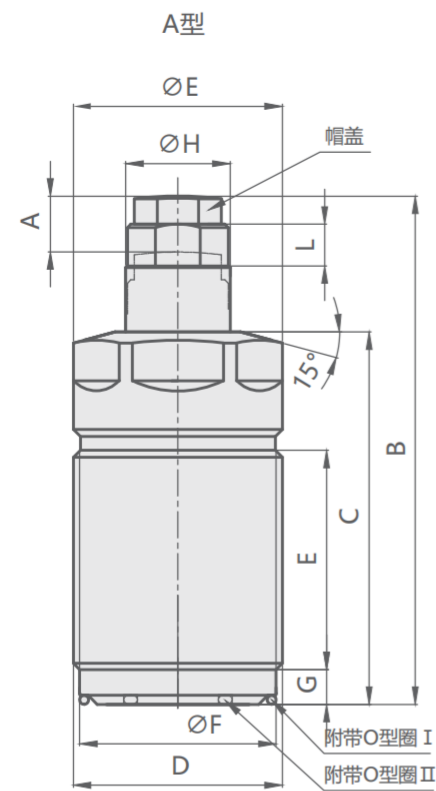

### 帽盖详图

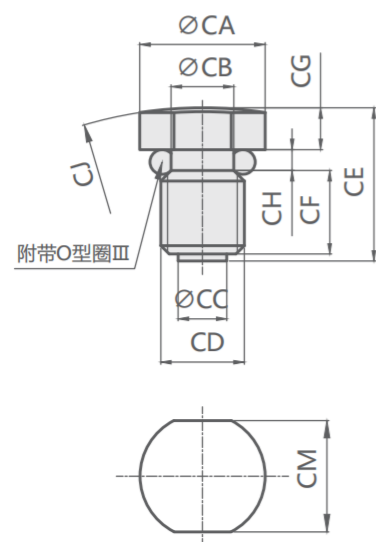

### 安装部位加工尺寸

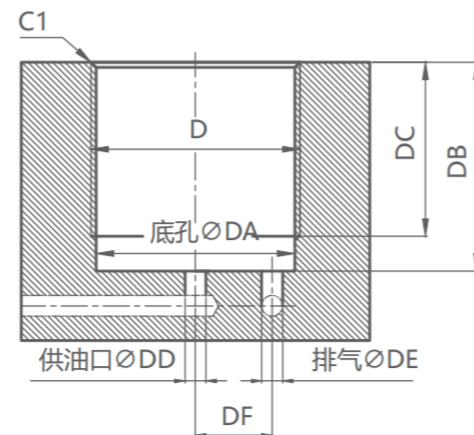

## 外形尺寸表

Unit:mm

型号 Model		CTNC-26	CTNC-30	CTNC-36	CTNC-45
A	行程	6.5	8	10	12
B	A型	66.5	73	86.5	100
	B型	60	65	76.5	88
C		48.5	53.5	64.5	71.5
D		M26×1.5	M30×1.5	M36×1.5	M45×1.5
E		27.5	31.5	51.2	55.2
F		24.2	28.2	34.2	43.2
G		5	5	5	6
H		12	15	18	22
J		10	13	14	19
K		24	27	32	41
L		6	6	6.5	9
CA		11.5	12.5	12.5	16.5
CB		6	7.8	7.8	9.7
CC		5	6	6	7.4
CD		M8	M10	M10	M12
CF		7.1	7.1	7.1	8
CE		14	14	14	18
CG		4	4	4	6
CH		1.9	1.9	1.9	3
CJ		SR30	SR50	SR50	SR80
CM		10	11	11	14
DA		24.5	28.5	34.5	43.5
DB		13~32	13~36	15~55	18~60
DC		DB-4	DB-4	DB-4	DB-5
DD		2~6	2~6	2~6	2~8
DE		2	22	3	3
DF		9.5	11	13	15
O型圈O-ring I		AS568-020(90°)	AS568-022(90°)	AS568-026(90°)	AS568-030(90°)
O型圈O-ring II		AS568-013(90°)	AS568-014(90°)	AS568-015(90°)	AS568-017(90°)
O型圈O-ring III		S6	S8	S8	S10

# CHP

## 高压支撑缸

# CHP HIGH PREESURE HYDRAULIC SUPPORT CLAMP



### 产品特性

- ★高耐压：使用压力范围为7~35MPa。
- ★通用的安装底座：与目前市售的日系缸拥有相同规格，具有互换性。

#### 液压上升型：

支撑杆初始位置为下降，供给油压使支撑杆上升并接触工件后停止，同时供给油压作用于夹套的加紧力施加于支撑杆，使支撑杆稳固的支撑工件

#### 弹簧上升型：

支撑杆初始位置为上升，放上工件，支撑杆就会因工件重量而下降到设定位置，然后在供给油压作用夹套的加紧力施加于支撑杆，使支撑杆稳固的支撑工件

### FEATURES

- ★High pressure: The range of working pressure is 7 ~ 35MPa.
- ★Universal mounting base: The CHP series is compatible and interchangeable with Japanese branded cylinders that are currently on the market.

#### Hydraulic Pressure Rising Type:

The initial state of the piston rod is down. When the oil pressure is supplied, the piston rod rises and stops once contact is made with the workpiece at any position. During this period, the hydraulic pressure on the collet can grip the plunger with stronger power to generate the supporting force.

#### Spring Rising Type:

The initial state of the piston rod is up, and the workpiece is placed on the piston rod and dropped to a certain distance due to the weight of the workpiece. During this period, the hydraulic pressure on the collet can grip the plunger with stronger power to generate the supporting force.

### 订购标示法 ORDERING INDICATION

#### 示例：CHP-30A

CHP	系列 Series	CHP
30	油缸外径 Hydraulic cylinder outside diameter	M30X1.5, M35X1.5, M50X1.5, M65X1.5
A	型式 Type	A:弹簧上升型 A:Spring rising type      B:液压上升型 B:Hydraulic pressure rising type

### 油压与支撑力的关系

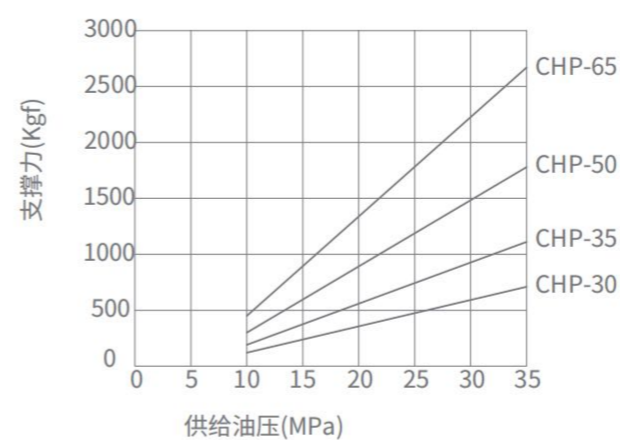

本图表示静态负荷条件下的支撑力

### 负荷与变位量的关系

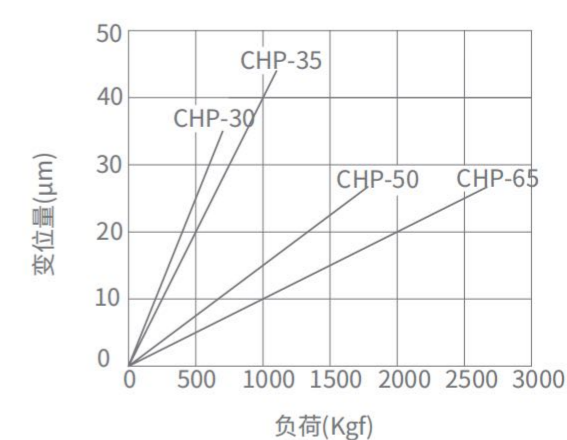

本图表示供给油压35MPa条件下静态负荷变位量

### 规格参数表 SPECIFICATIONS

型号	支撑力 (油压35MPa时)	油缸容量	上升弹簧力	支撑杆行程	最高使用压力	最低使用压力	使用温度	质量
MODEL	WORKPIECE SUPPORT FORCE WHEN OIL PRESSURE IS 35MPa(kgf)	OIL CYLINDER CAPACITY(cm <sup>3</sup> )	RISING SPRING FORCE(N)	STROKE FOR SUPPORT ROD(mm)	MAX. WORKING PRESSURE(MPa)	MIN. WORKING PRESSURE(MPa)	OPERATING TEMPERATURE(°C)	QUALITY(Kg)
CHP-30	710	1.5	6~11	8	35	10	0~70°C	0.29
CHP-35	1100	2.9	10~16	10	35	10	0~70°C	0.43
CHP-50	1780	5.5	16~29	10	35	10	0~70°C	1.03
CHP-65	2670	5.7	25~45	13	35	10	0~70°C	1.89

### 注意事项

- 1.当支撑缸与夹紧缸对置使用时，选型时一定注意，所选支撑缸支撑力应大于夹紧缸夹紧力的1.5倍以上。
- 2.自制接触螺栓时请参照帽盖详图尺寸，且需考虑接触螺栓的重量及弹簧力，否则会出现支撑缸动作不良的现象。
- 3.保持通过排气口供气，可有效的防止切削液、切削粉尘等侵入支撑缸内部。
- 4.请避免以下的使用方法，否则会导致支撑缸动作不良及支撑力下降。  
A: 向支撑杆上施加偏心负荷  
B: 施加超过额定支撑力的负荷  
C: 支撑工作时转动支撑杆

### NOTE

- 1.When the support clamp and cylinder clamp are used opposite from each other, pay attention to the selection, the supporting force should be more than 1.5 times of the cylinder clamping force.
- 2.Please refer to the cap detailed drawing when the user makes the cap, and consider the weight of the cap and the spring force, otherwise there will be poor operation of the support cylinder.
- 3.Keep the vent hole open to the atmosphere, which can effectively prevent cutting fluid and cutting dust from invading the inside of the support cylinder.
- 4.Please avoid the following usage methods, otherwise it will cause poor operation of the support cylinder and a decrease in supporting force.  
A: Apply an eccentric load to the support rod  
B: Apply a load exceeding the rated supporting force  
C: Rotate the support rod when supporting work

## 外形尺寸

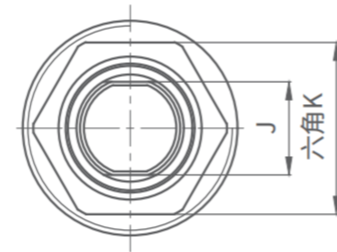
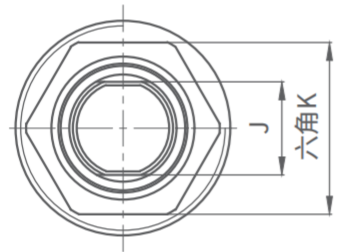
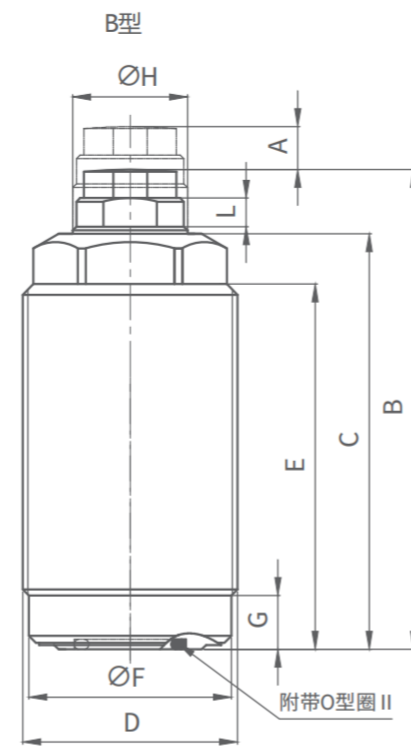
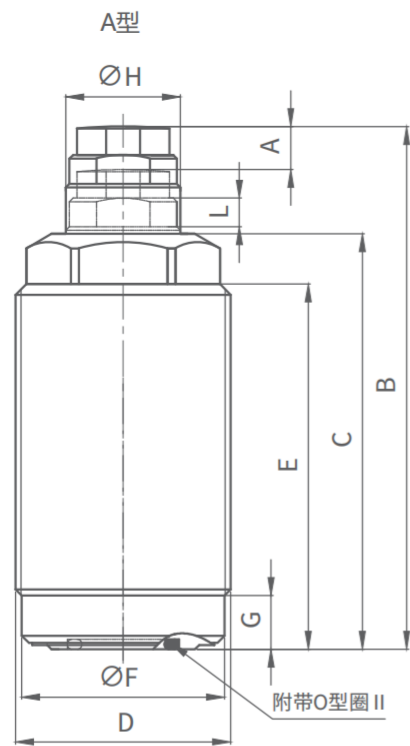

## 帽盖详图

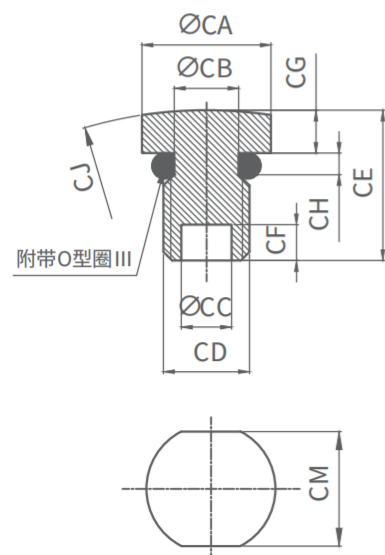

## 安装部位加工尺寸

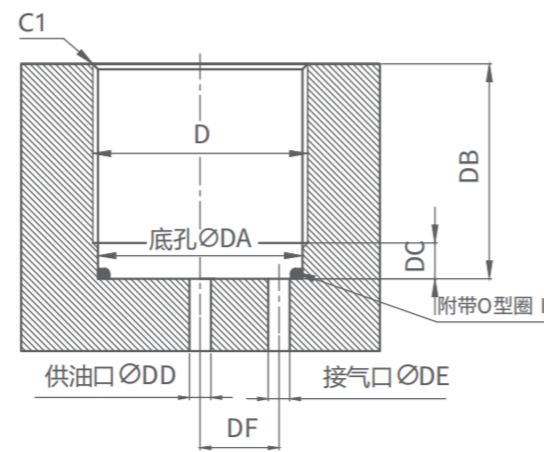

## 外形尺寸表

Unit:mm

型号 Model		CHP-30	CHP-35	CHP-50	CHP-65
A	行程	8	10	10	13
B	A型	75	87	94	109
	B型	67	77	84	96
C		58	67	71.8	82
D		M30×1.5	M35×1.5	M50×1.5	M65×1.5
E		51	58	59.5	68.5
F		28.3	33.2	48.2	63.2
G		7.5	7.5	7.5	8
H		16	20	30	40
J		13	17	24	32
K		12	14	19	24
L		4	5	5	5.7
CA		>12.9	>16.9	>23	>30
CB		7.8	8.9	13.3	13.3
CC		7.4	7.6	9.2	11.2
CD		M10	M12	M16	M16
CF		1.5	3.5	1.5	1.5
CE		13	15	18	18
CG		4	4	6	7
CH		1.9	3	2.4	2.4
CJ		SR70	SR90	SR110	SR140
CM		12	14	19	24
DA		28.5	33.5	48.5	63.5
DB		20~51	20~25	20~59.5	20~68.5
DC		<6.5	<6.5	<6.5	<7
DD		2~8	2~8	2~8	2~8
DE		2	2	3	3
DF		11	12	18	23.5
O型圈O-ring I		AS568-022(90°)	AS568-025(90°)	S45(90°)	AS568-036(90°)
O型圈O-ring II		AS568-014(90°)	AS568-015(90°)	AS568-019(90°)	AS568-022(90°)
O型圈O-ring III		S8	P9	AS568-014(70°)	AS568-014(70°)

# CSP

## 油压支撑缸 (高压)

### CSP HYDRAULIC SUPPORT CLAMP (HIGH PRESSURE)

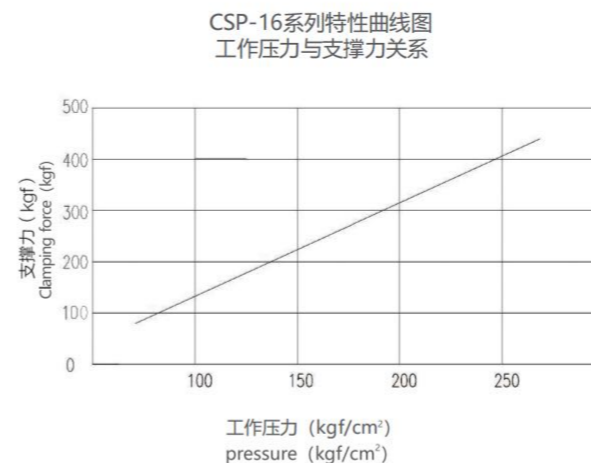
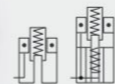

※本图表示静态负荷条件下的支撑力

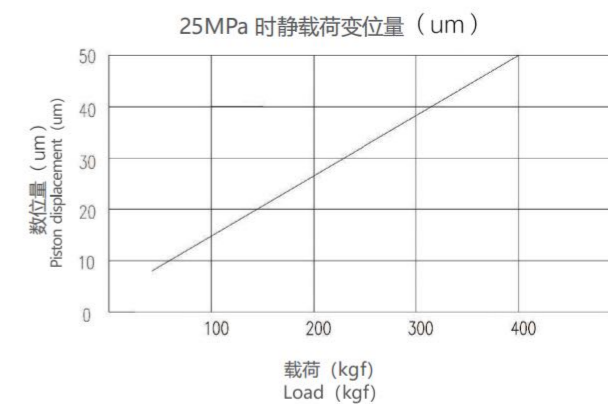

#### 产品特性

A型: 夹缩支撑在初始位置时,支撑头在内部弹簧的作用下处于最上端,工作时依靠工件在下放时的重力下压支撑头使之同步向下,在工件稳妥的放在治具上时就停止下行,支撑头也停止下行,加油压后支撑缸锁死给工件提供支撑并停止运行。

B型: 上行支撑,在初始位置时,支撑头位于最下端,工件放好后给支撑缸加油压使支撑头上行,至碰到工件时支撑头立刻停止上行并继续加压至锁死,这样支撑头就在当前位置给工件提供支撑并且停止。

最大操作压力:250 kgf/cm<sup>2</sup>  
最小操作压力:100 kgf/cm<sup>2</sup>  
作动方式:单动式

#### 注意事项

支持力与转角缸的支持力要相匹配  
支持力至少为单个转角缸支持力的150%  
不能超过最大流速,避免过早锁死  
基本上在中间位置放置支撑缸  
安装时盖可能垂直于工作面,倾斜勿超过10°  
如操作压力大于250kgf/cm<sup>2</sup>,请来电洽询

#### FEATURES

TypeA:The initial state of the piston rod is down. When the oil pressure is supplied, the piston rod rises and stops once contact is made with the workpiece. During this period, the hydraulic pressure on the collet can grip the plunger with stronger power to generate the supporting force.

TypeB:The initial state of the piston rod is up, and the workpiece is placed on the piston rod and dropped to a certain distance due to the weight of the workpiece. During this period, the hydraulic pressure on the collet can grip the plunger with stronger power to generate the supporting force.

Max.operating pressure:250 kgf/cm<sup>2</sup>  
Min.operating pressure :100 kgf/cm<sup>2</sup>  
Single acting

#### NOTE

The supporting force must match the clamp force of the swing clamp.  
The supporting force at least is equal to 150% of the clamp force of a swing clamp.  
Do not exceed the maximum velocity of flow and avoid clamping it too early.  
Install the supporting cylinder in the middle place best.  
The angle degree between the supporting cylinder and working force could not be larger than 10% while installing.  
Please contact us when the operating pressure exceed 250kgf/cm<sup>2</sup>.

#### CSP-16A

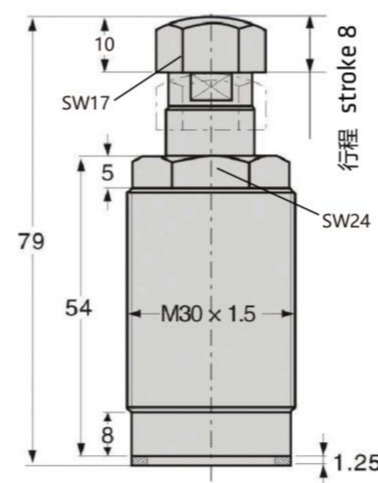

#### CSP-16B

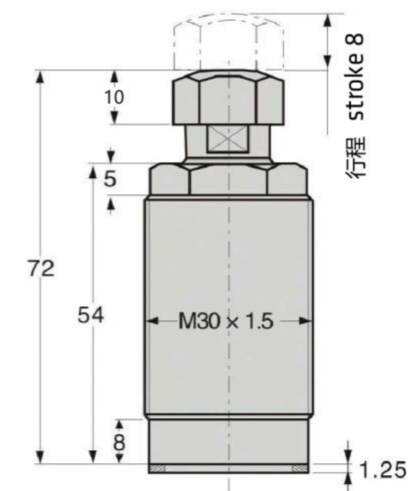

#### 安装尺寸

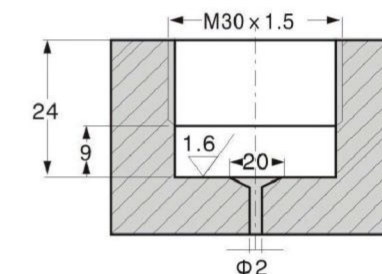

#### 订购标示法 ORDERING INDICATION

##### 示例: CSP-16A

CSP	系列 Series	CSP
16	油塞杆径 Piston rod diameter	Φ16
A	型式 Type	A:Type A    B:Type B

#### 规格参数表 SPECIFICATIONS

型号	理论支撑力(250 kgf/cm <sup>2</sup> )	理论支撑力(100 kgf/cm <sup>2</sup> )	总行程	油压容积	活塞杆面积	使用流体
MODEL	CLAMPING FORCE AT 250 kgf/cm <sup>2</sup> (kgf)	CLAMPING FORCE AT 100 kgf/cm <sup>2</sup> (kgf)	TOTAL STROKE(mm)	OIL CAPACITY CLAMP(cm <sup>3</sup> )	OIL CAPACITY UNCLAMP(cm <sup>3</sup> )	USABLE FLUID
CSP-16A	410	140	8	0.60	2.01	相当于ISO黏度等级的 ISO-VG-32 一般液压油 Recommended: ISO-VG-32 hydraulic oil equivalent to ISO viscosity grade
CSP-16B	410	140	8	0.60	2.01	

# HSP

## 油压支撑缸 (高压)

### HSP HYDRAULIC SUPPORT CLAMP (HIGH PRESSURE)

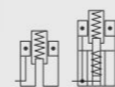

HSP-16系列特性曲线图  
工作压力与支撑力关系

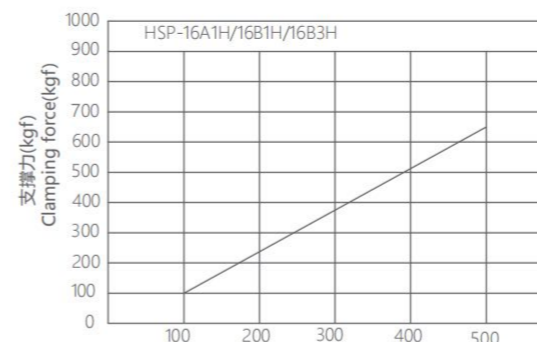

工作压力(kgf/cm²)  
pressure(kgf/cm²)  
※本图表示静态负荷条件下的支撑力

HSP-16系列特性曲线图  
工作压力与支撑力关系

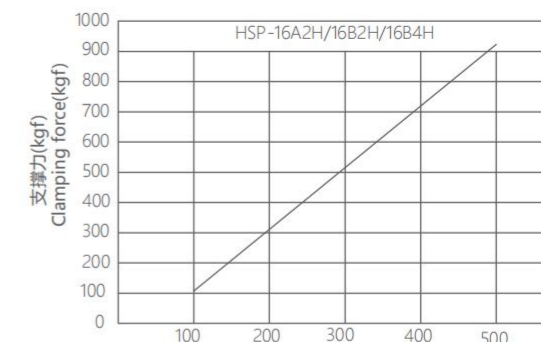

工作压力(kgf/cm²)  
pressure(kgf/cm²)  
※本图表示静态负荷条件下的支撑力

#### 产品特性

A型: 夹缩支撑在初始位置时,支撑头在内部弹簧的作用下处于最上端,工作时依靠工件在下放时的重力下压支撑头使之同步向下,在工件稳妥的放在治具上时就停止下行,支撑头也停止下行,加油压后支撑缸锁死给工件提供支撑并停止运行。  
B型: 上行支撑,在初始位置时,支撑头位于最下端,工件放好后给支撑缸加油压使支撑头上行,至碰到工件时支撑头立刻停止上行并继续加压至锁死,这样支撑头就在当前位置给工件提供支撑并且停止。

最大操作压力: 500 kgf/cm²  
最小操作压力: 100kgf/cm²  
作动方式: 单动式

#### 注意事项

支持力与转角缸的支持力要相匹配  
支持力至少为单个转角缸夹持力的150%  
不能超过最大流速, 避免过早锁死  
基本上在中间位置放置支撑缸  
安装时盖可能垂直于工作面, 倾斜勿超过10°

#### FEATURES

TypeA: The initial state of the piston rod is down. When the oil pressure is supplied, the piston rod rises and stops once contact is made with the workpiece at any position. During this period, the hydraulic pressure on the collet can grip the plunger with stronger power to generate the supporting force.  
TypeB: The initial state of the piston rod is up, and the workpiece is placed on the piston rod and dropped to a certain distance due to the weight of the workpiece. During this period, the hydraulic pressure on the collet can grip the plunger with stronger power to generate the supporting force.

Max. operating pressure : 500 kgf/cm²  
Min. operating pressure : 100 kgf/cm²  
Single acting

#### NOTE

The supporting force must match the clamp force of the swing clamp.  
The supporting force at least is equal to 150% of the clamp force of a swing clamp.  
Do not exceed the maximum velocity of flow and avoid clamping it too early.  
Install the supporting cylinder in the middle place best.  
The angle degree between the supporting cylinder and working force could not be larger than 10% while installing.

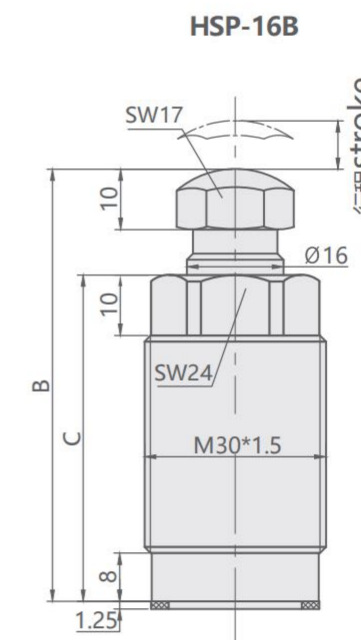
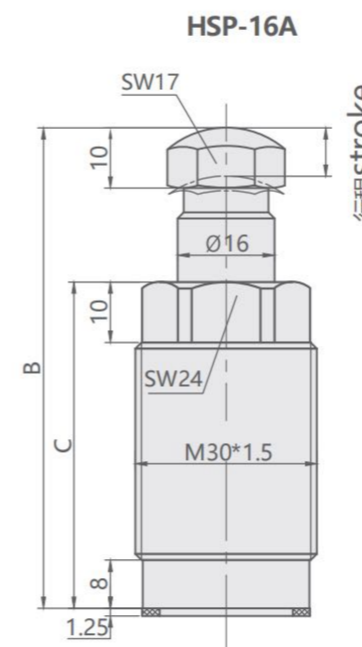

#### 订购标示法 ORDERING INDICATION

示例: HSP-16B1H

HSP	系列 Series	HSP
16	油塞杆径 Piston rod diameter	Φ16
B	型式 Type	A:Type A    B:Type B
1H	行程 Stroke	详见HSP规格参数表 Please refer to the detailed with specifications

型号	支撑力(500 kgf/cm²)	活塞杆行程	油缸容积	B	C	使用温度范围	使用流体
MODEL	CLAMPING FORCE AT 500 kgf/cm² (kgf)	TOTAL STROKE(mm)	OIL CAPACITY CLAMP(cm³)			RANGE OF TEMPERATURE(°C)	USABLE FLUID
HSP-16A1H	650	8	1.49	79	54	0~+70°C	相当于ISO 粘度等级的 ISO-VG-32 一般液压油 General Hydraulic Oil Equivalent to ISO-VG-32
HSP-16A2H	950	8	2.11	89	64	0~+70°C	
HSP-16B1H	650	8	2.12	71	54	0~+70°C	
HSP-16B2H	950	8	2.74	81	64	0~+70°C	
HSP-16B3H	650	15	2.67	78	61	0~+70°C	
HSP-16B4H	950	15	3.28	88	71	0~+70°C	

# SP-AH

气油压两用型支撑缸

SP-AH PNEUMATIC/  
HYDRAULIC  
SUPPORT CLAMP



油压 Hydraulic

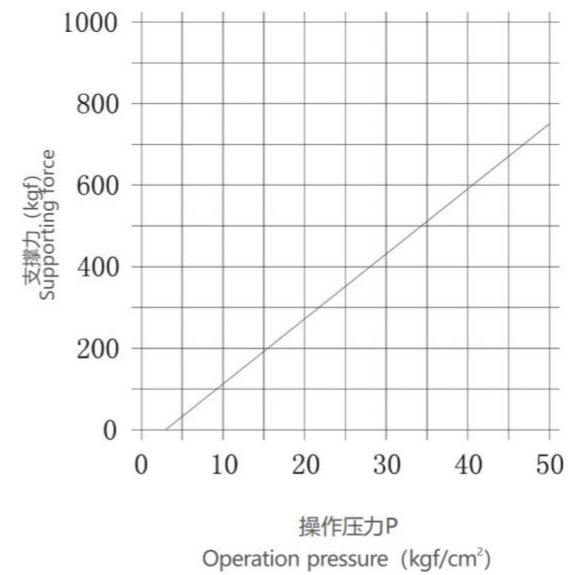

气压 Pneumatic

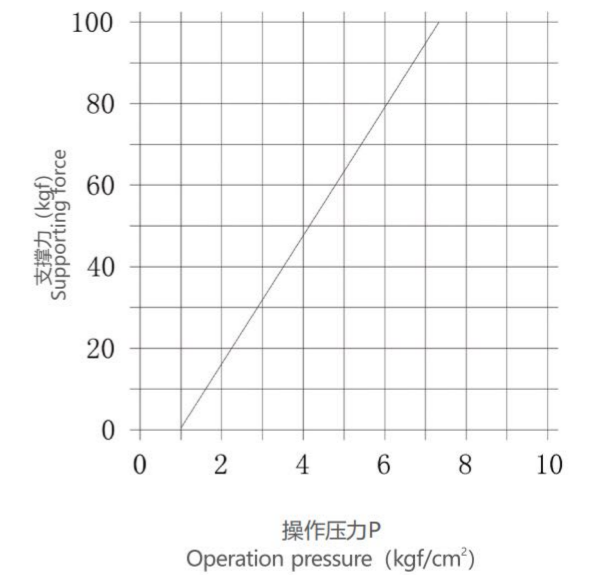

订购标示法 ORDERING INDICATION

示例: SP-AH18RA

SP	系列 Series	SP
AH	气油压两用型	Pneumatic/hydraulic type
18	顶杆轴径	Diameter of the extended piston rod
R	R: 右向 L: 左向	R: Turn right L: Turn left
A	A: 弹簧顶出型 B: 油压顶出型	A: Spring extended piston B: Hydraulic extended piston

A: 弹簧顶出型, 往内调整  
B: 油压顶出型, 往外调整  
附AB型式调整螺丝

A: Spring extended piston rod-adjust inward.  
B: Hydraulic extended piston rod-adjust outward.  
With A and B type adjusting screw.

使用流体: 相当于黏度等级的ISO-VG-32一般液压油或过滤之干燥压缩空气  
Recommended: ISO-VG-32 hydraulic oil equivalent to ISO viscosity grade or oiled dry clean compressed air.

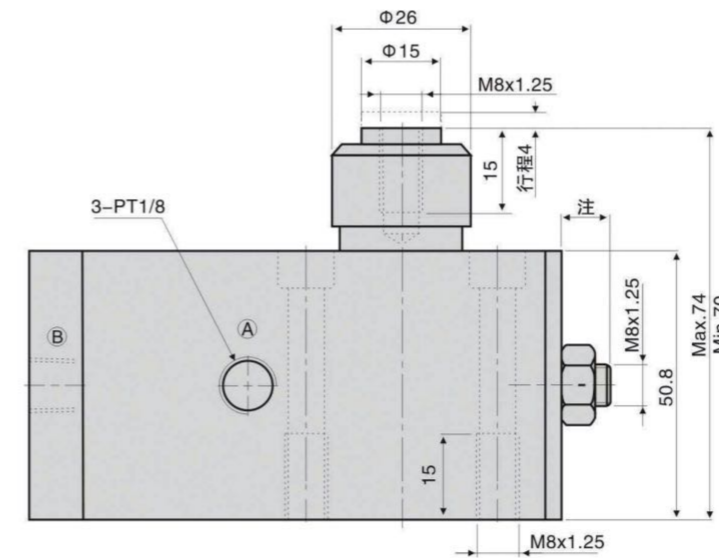

Ⓐ 顶出油孔 Extending port  
Ⓑ 退回油孔 Retracting port

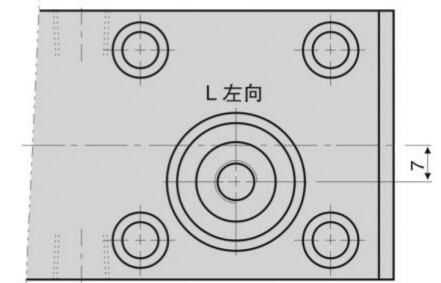
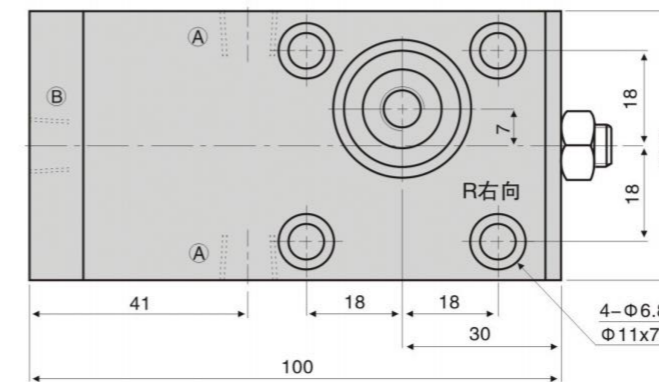

# CLLW

## 内置气检式油压直线缸

## CLLW AIR SENSOR BUILT-IN LINEAR CYLINDER



### 产品特性

该系列产品是在CLL系列产品的基础上进行优化设计，通过连接空气传感器，检出压差，实现确认动作，通过伸出/拉回动作确认，能实现安全可靠地将工件搬入搬出。

最大操作压力：70kgf/cm<sup>2</sup>  
最小操作压力：5kgf/cm<sup>2</sup>

### FEATURES

This series of products is an optimized design based on the CLL series products. By connecting an air sensor, it detects the pressure difference and realizes the confirmation action. Through the extension/retraction confirmation, it can safely and reliably move the workpiece in and out.

Max. operating pressure: 70kgf/cm<sup>2</sup>  
Min. operating pressure: 5kgf/cm<sup>2</sup>

### 订购标示法 ORDERING INDICATION

示例: CLLW-036CAE-050

CLLW	系列 Series	CLLW
036	本体尺寸 Body size	036: ØD36mm 040: ØD40mm 048: ØD48mm ØD表示本体油缸外径尺寸 Outer diameter ØD of the cylinder
C	板式连接型 (附带G螺纹堵头) Gasket option(with G thread plug)	可安装速度控制阀 (CZL) (用户另行购买) A speed control valve can be installed, recommended CZL, please order separately.
A	活塞杆前端形状 Shape of Piston Tip	A: 内螺纹型 Female Threaded B: 内螺纹型 (附带旋转防止销孔) Female Threaded(With anti-rotation pin-hole) T: 外螺纹型 Male Threaded P: 销孔连接型 Pin-Hole Option
E	传感阀符号 Sensor valve symbol	E: 推出、拉回动作确认型 Push pull confirmation (both) H: 推出动作确认型 Push confirmation only J: 拉回动作确认型 Pull confirmation only
050	行程 Stroke	

### 规格参数表 SPECIFICATIONS

型号 MODEL	总行程 (以5mm为单位) Full Stroke Y (mm)	油缸面积 Cylinder Area(cm <sup>2</sup> )		油缸输出力 (计算公式) Cylinder force (Calculation Formula) KN		油缸容量(计算公式) Cylinder Capacity (Calculation Formula) cm <sup>3</sup>		油缸内径 Cylinder inside diameter (mm)	活塞杆径 Rod Diameter(mm)
		推侧 Push Side	拉侧 Pull Side	推侧 Push Side	拉侧 Pull Side	推侧 Push Side	拉侧 Pull Side		
CLLW-036	10~50	4.5	2.5	Px0.45	Px0.25	Yx0.45	Yx0.25	Ø24	Ø16
CLLW-040	10~50	5.3	2.8	Px0.53	Px0.28	Yx0.53	Yx0.28	Ø26	Ø18
CLLW-048	10~75	8.0	4.9	Px0.80	Px0.49	Yx0.80	Yx0.49	Ø32	Ø20

型号 MODEL	最高使用压力 Max. Operating Pressure(Mpa)	最低动作压力 Min. Operating Pressure(MPa)	耐压 Withstanding Pressure(MPa)	使用温度 Operating Temperature(°C)	推荐使用空气压力 Recommend using air pressure(MPa)	重量 Weight (kg)
CLLW-036	7.0	0.5	10.5	0~70	0.1~0.2	0.6~0.8
CLLW-040	7.0	0.5	10.5	0~70	0.1~0.2	0.7~0.9
CLLW-048	7.0	0.5	10.5	0~70	0.1~0.2	1.0~1.6

注意事项:P表示供给油压(MPa)、Y表示全行程 使用流体相当于ISO黏度等级的ISO-VG-32一般液压油

### 能力计算表 ABILITY CALCULATION TABLE

型号	油缸推侧输出力							油缸拉侧输出力						
	1MPa	2MPa	3MPa	4MPa	5MPa	6MPa	7MPa	1MPa	2MPa	3MPa	4MPa	5MPa	6MPa	7MPa
CLLW-036	0.4	0.9	1.3	1.8	2.2	2.7	3.1	0.2	0.5	0.7	1.0	1.2	1.5	1.7
CLLW-040	0.5	1.0	1.5	2.1	2.6	3.1	3.7	0.2	0.5	0.8	1.1	1.4	1.6	1.9
CLLW-048	0.8	1.6	2.4	3.2	4.0	4.8	5.6	0.4	0.9	1.4	1.9	2.4	2.9	3.4

### 注意事项:

- 1.本图表示油缸输出力与供给油压之间的关系。
- 2.油缸输出力F(KN)为理论输出值。实际输出力会受油缸活塞滑动部分的阻力及油压设备、配管的压力损失等压力的影响，可能会减少一部分。

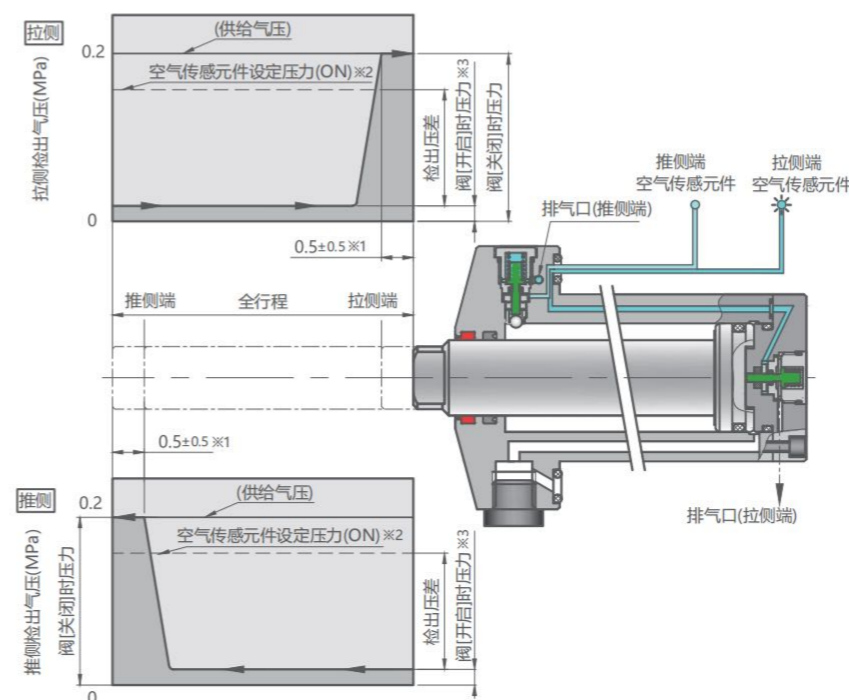

空气传感流程图  
连接1台直线夹器时

### 注意事项

- 1.本空气传感流程图表示行程检出回路压力的关系曲线。
- 2.有时会因空气回路的构成特性会有变化。推荐连接用气管的长度请尽量缩短。(基准为5m以内)
- 3.传感器符号为  $\square$  时, 仅检测推侧端, 传感器符号为  $\square$  时, 仅检测拉侧端。  
\* 1.传感阀 [关闭] 状态的压力位置由于夹器构造存在容许差。(请参考空气传感流程图)  
\* 2.空气传感器输出ON信号的位置会随传感器的设定而发生变化。  
\* 3.传感器 [开启] 时传感压力根据所使用的空气传感器会有不同。空气消费量多的空气传感器在传感阀 [开启] 时的传感压力会高些, 使得检出压差变小。

## 外形尺寸

※本图为CLLW-CAE/CLLW-CBE

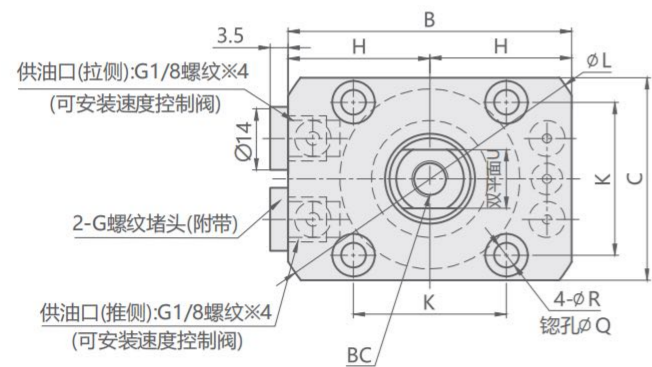
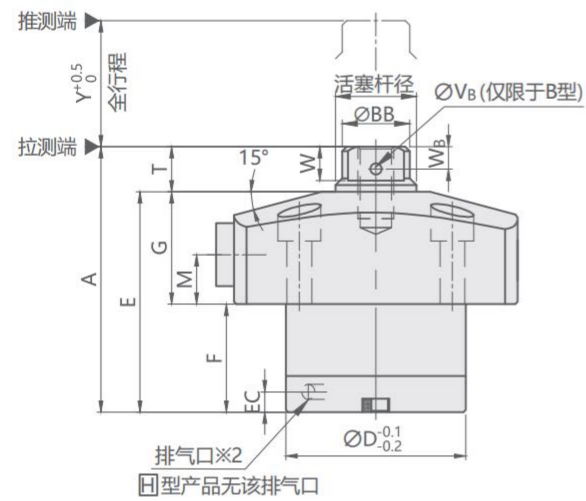
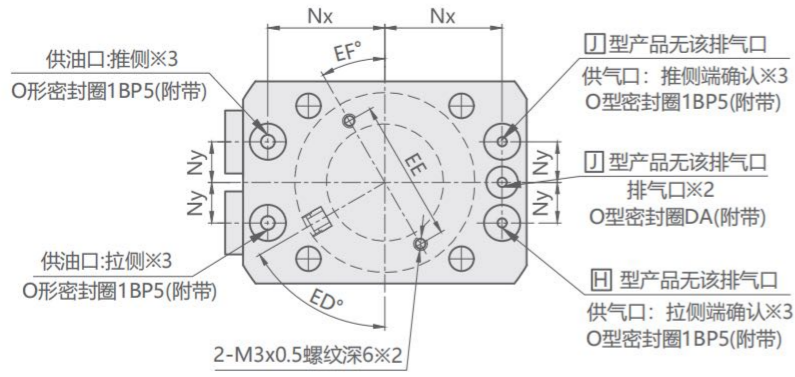

### 注意事项

- ※1. 本产品未附带安装螺栓。请用户参照S尺寸并根据安装高度自行配备。
- ※2. 排气孔必须进行大气开放，且务必防止冷却液，切削液的侵入。冷却液会直接飞溅到时，请在M3螺纹上设置垫块，有效防止冷却液的侵入，且务必保证排气孔不被堵塞。
- ※3. 本产品未附带速度控制阀。请用户另行购买。

### NOTE

- ※1. This product does not come with installation bolts. Please refer to the S size and configure it by yourself according to the installation height.
- ※2. The exhaust holes must be open to the atmosphere and it is essential to prevent the intrusion of coolant and cutting fluid. The coolant may splash directly. Please set a pad on the M3 thread to effectively prevent the coolant from entering and make sure that the vent hole is not blocked.
- ※3. This product does not come with a speed control valve. Please purchase separately.

## 柱塞前端形状

P: 销孔连接型

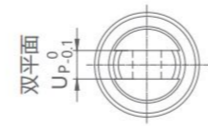
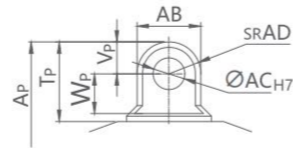

T: 内螺纹型(附带防止旋转销孔)

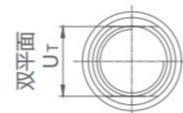
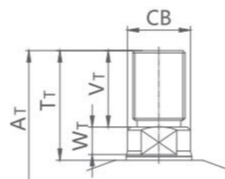

## 安装部位加工尺寸

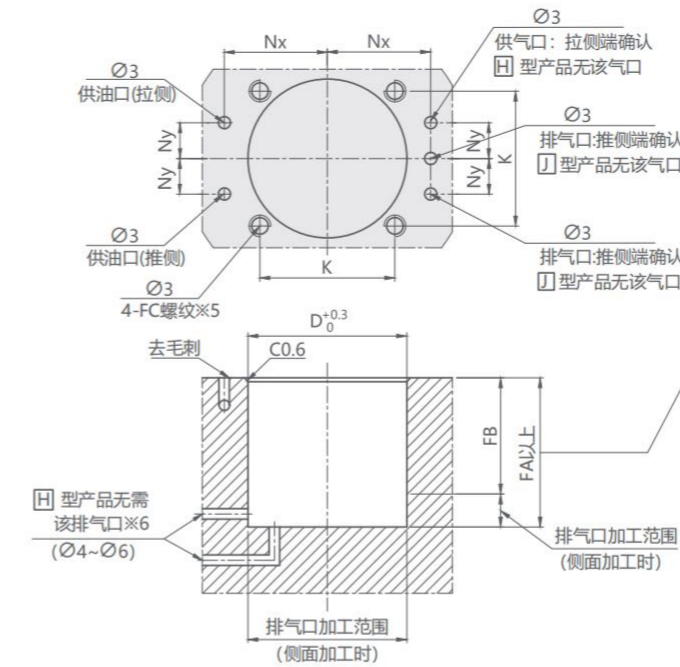

安装孔为下图所示的贯通孔时，无需遵守FA尺寸，可任意决定板厚

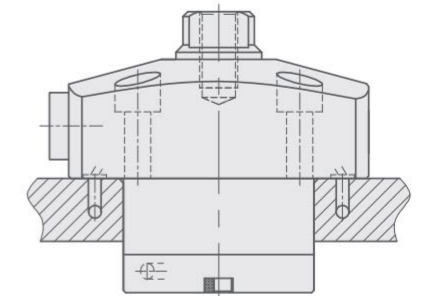

### 注意事项

- ※5. 请参考S尺寸，并根据安装高度决定安装螺栓的FC螺纹深度。
- ※6. 安装孔为贯通孔时，无需排气口

## 外形尺寸表及安装部位加工尺寸表

A: 内螺纹型 B: 内螺纹型(附带旋转防止销孔)

(mm)

(例) CLLW-036CA □-010时 {Y=10, A=58, E=49, F=24}  
CLLW-036CA □-030时 {Y=30, A=73, E=64, F=39}

型号	CLLW-036CA	CLLW-040CA	CLLW-048CA
全行程Y	10, 15	20~50 (以5mm为单位)	10, 15
A	58	Y+43	59
B	58	63	71
C	40	45	51
D	36	40	48
E	49	Y+34	49
F	24	Y+9	24
G	25	25	28
H	29	31.5	35.5
K	31.4	34	40
L	66	73	83
M	11	11	12
Nx	23.5	26	30
Ny	8	9	11
Q	7.5	9.5	9.5
R	4.5	5.5	5.5
S	16	14	15.5
T	9	10	11
U	12	13	14
W	7.5	7.5	8.5
BB	14	15	17
BC(名称+深度)	M6x12	M6x12	M6x12
V <sub>B</sub> (仅限于B型)	2	2.5	2.5
W <sub>B</sub> (仅限于B型)	5.5	5	6
EC	4.5	4.5	4.5
ED	45°	60°	60°
EE	30	31.6	39
EF	30°	0	0
FA	24.5	Y+9.5	24.5
FB	15.5	Y+0.5	15.5
FC	M4x7	M5x0.8	M5x0.8
O型密封圈	DA AS568-006(90°)	AS568-007(90°)	1BP5

P: 销孔连接型

型号	CLLW-036CP	CLLW-040CP	CLLW-048CP
全行程Y	10, 15	20~50 (以5mm为单位)	10, 15
A <sub>P</sub>	64	Y+49	68
AB	12	15	17
AC	6 <sup>+0.012</sup> <sub>0</sub>	8 <sup>+0.015</sup> <sub>0</sub>	8 <sup>+0.015</sup> <sub>0</sub>
AD	6	8	9
T <sub>P</sub>	15	19	21
U <sub>P</sub>	6	8	10
V <sub>P</sub>	6	8	9
W <sub>P</sub>	7.5	9.5	10.5

T: 外牙螺纹型

型号	CLLW-036CT	CLLW-040CT	CLLW-048CT
全行程Y	10, 15	20~50 (以5mm为单位)	10, 15
A <sub>T</sub>	74	Y+59	79
T <sub>T</sub>	25	30	35
U <sub>T</sub>	12	14	17
V <sub>T</sub>	16	20	24
W <sub>T</sub>	7.5	7.5	8.5
CB	14	17	19
CC(名称×螺纹)	M10x1.25	M12x1.25	M14x1.5

# CLL

## 油压紧凑型直线缸

### CLL HYDRAULIC COMPACT LINEAR CYLINDER



#### 产品特性

以最小空间实现大的行程,CLL/CLLR/CLLU 可以1mm为单位指定行程又可以在丰富组合中进行选择。

#### FEATURES





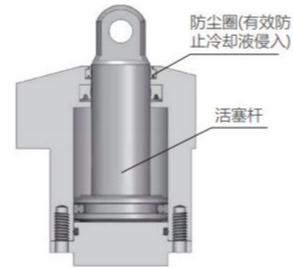

Maximum stroke is available with minimum space. CLL/CLLR/CLLU with 1 mm stroke increments and a variety of styles.

#### 剖面图 Sectional view

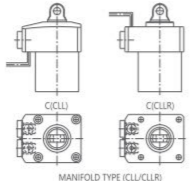
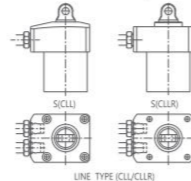
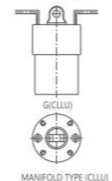

#### 订购标示法 ORDERING INDICATION

##### 示例: CLL-048CA-050

CLL	系列 Series	CLL		
	安装方式 Mounting Methods	 CLL:法兰下部安装型 Top Flange	 CLLR:法兰上部安装型 Bottom Flange	 CLLU:法兰上部安装型(节省空间型) Bottom Flange (Compact)
048	本体尺寸 Body Size	036:ΦD=36 065:ΦD=65	040:ΦD=40 075:ΦD=75	048:ΦD=48 090:ΦD=90 055:ΦD=55 105:ΦD=105
	配管方式 Piping Method	C:板式连接型(附带G螺纹堵头, 对应CLL/CLLR型) S:配管型(Rc螺纹, 对应CLL/CLLR型) G:板式连接型(只有板式供油口, 对应CLLU型)		C: Gasket Option (With G Thread Plug, Apply to CLL/CLLR) S: Piping Option (Rc Thread Port, Apply to CLL/CLLR) G: Gasket Option (Gasket Port only, Apply to CLLU)
C		 MANIFOLD TYPE (CLL/CLLR) 油接板型(CLL/CLLR)	 LINE TYPE (CLL/CLLR) 配管式(CLL/CLLR)	 MANIFOLD TYPE (CLLU) 油接板型(CLLU)
A	活塞前端形状 Shape of Piston Tip	A: 内螺纹型 B:内螺纹型(附带旋转防止销孔) T: 外螺纹型 P:销孔连接型 A: Female Threaded B: Female Threaded (With Anti-Rotation Pin-hole) T: Male Threaded P: Pin-Hole Option		   
050	行程 Stroke			



C:板式连接型(配有G螺纹堵头) C: Gasket Option(with G Thread Plug)  
 P:销孔连接型 本图表示 CLL-CP型 P: Pin-Hole Option \*This drawing indicates CLL-CP

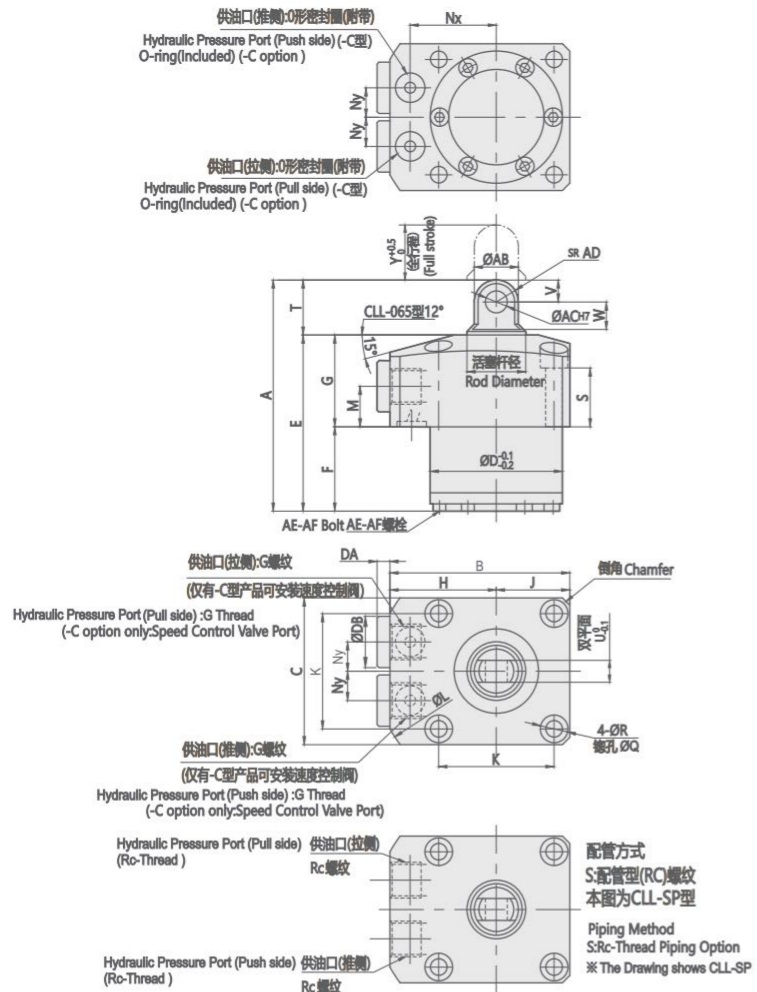

Tip Shape Refer P Pinhole dimension for not mentioned size below  
 柱端形状 无记载的尺寸请参考销孔连接型

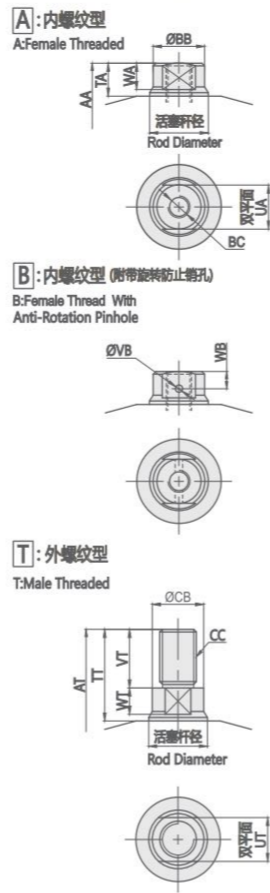

## 规格参数表 SPECIFICATIONS

型号 MODEL	总行程 Full Stroke Y (mm)	油缸面积 Cylinder Area (cm²)		油缸输出力 Cylinder force (计算公式) (Calculation Formula) KN		油缸容量(计算公式) Cylinder Capacity (Calculation Formula) cm³		油缸内径 Cylinder inside diameter (mm)	活塞杆径 Rod Diameter(mm)	最高使用压力 Max. Operating Pressure(Mpa)	最低动作压力 Min. Operating Pressure(Mpa)	耐压 Withstanding Pressure(Mpa)	使用温度 Temperature (°C)	重量 Weight (kg)
		推侧 Push Side	拉侧 Pull Side	推侧 Push Side	拉侧 Pull Side	推侧 Push Side	拉侧 Pull Side							
CLL-036	1~50	4.5	2.5	P×0.45	P×0.25	Y×0.45	Y×0.25	Φ24	Φ16	7.0	0.5	10.5	0~70	0.6~0.8
CLL-040	1~50	5.3	2.8	P×0.53	P×0.28	Y×0.53	Y×0.28	Φ26	Φ18	7.0	0.5	10.5	0~70	0.7~0.9
CLL-048	1~75	8.0	4.9	P×0.80	P×0.49	Y×0.80	Y×0.49	Φ32	Φ20	7.0	0.5	10.5	0~70	1.0~1.6
CLL-055	1~75	9.6	5.8	P×0.96	P×0.58	Y×0.96	Y×0.58	Φ35	Φ22	7.0	0.5	10.5	0~70	1.3~2.1
CLL-065	1~75	15.9	11.0	P×1.59	P×1.10	Y×1.59	Y×1.10	Φ45	Φ25	7.0	0.5	10.5	0~70	1.9~3.1
CLL-075	1~75	23.8	16.7	P×2.38	P×1.67	Y×2.38	Y×1.67	Φ55	Φ30	7.0	0.5	10.5	0~70	2.8~4.1
CLL-090	1~75	36.3	26.4	P×3.63	P×2.64	Y×3.63	Y×2.64	Φ68	Φ35.5	7.0	0.5	10.5	0~70	4.3~6.1
CLL-105	1~75	50.3	34.4	P×5.03	P×3.44	Y×5.03	Y×3.44	Φ80	Φ45	7.0	0.5	10.5	0~70	5.9~8.0

使用流体: 相当于ISO黏度等级的ISO-VG-32一般液压油 Usable fluid: General Hydraulic Oil Equivalent to ISO-VG-32

### A:内螺纹型 Female Threaded

Unit:mm

型号 Model	CLL-036	CLL-040	CLL-048	CLL-055	CLL-065	CLL-075	CLL-090	CLL-105
AA	57 Y+42	61 Y+46	64 Y+49	68 Y+53	75 Y+60	83 Y+68	93 Y+78	99 Y+84
TA	9	10	11	12	13	15	16	18
UA	12	13	14	17	19	24	30	36
WA	7.5	7.5	8.5	9	10	12	13	15
BB	14	15	17	19	22	27	33	42
BC (名称x深度) (Nominal x Depth)	M6×12	M8×16	M8×16	M10×20	M12×24	M16×32	M20×40	M24×48

无记载的尺寸请参考P: 销孔连接型。  
 Refer P pinhole option dimension for not mentioned size below.

全行程Y=1~14mm时, 外形尺寸与行程15mm时的油缸是一样的(例)  
 CLL-036□P-010 [Y=10, A=63, E=48, F=23] CLL-036□P-030  
 [Y=30, A=78, E=63, F=38]

※ Calculation formula is different between full stroke: Y=1-14 mm and  
 Y= more than 15 mm.Ex.) CLL-036□P-010 [ Y=10, A=63, E=48, F=23  
 ]CLL-036□P-030 [ Y=30, A=78, E=63, F=38 ]

### P:销孔连接型 Pin-Hole Option

Unit:mm

型号 Model	CLL-036	CLL-040	CLL-048	CLL-055	CLL-065	CLL-075	CLL-090	CLL-105
全行程 Full Stroke Y	1~14 15~50	1~14 15~50	1~14 15~75	1~14 15~75	1~14 15~75	1~14 15~75	1~14 15~75	1~14 15~75
A	63 Y+48	70 Y+55	74 Y+59	80 Y+65	90 Y+75	101 Y+86	114 Y+99	127 Y+112
B	49	54	61	69	81	92	107	122
C	40	45	51	60	70	80	95	110
D	36	40	48	55	65	75	90	105
E	48 Y+33	51 Y+36	53 Y+38	56 Y+41	62 Y+47	68 Y+53	77 Y+62	81 Y+66
F	23 Y+8	26 Y+11	25 Y+10	28 Y+13	32 Y+17	31 Y+16	37 Y+22	36 Y+21
G	25	25	28	28	30	37	40	45
H	29	31.5	35.5	39	46	52	59.5	67
J	20	22.5	25.5	30	35	40	47.5	55
K	31.4	34	40	47	55	63	75	88
L	66	73	83	88	106	116	136	152
M	11	11	12	12	13	16	16	17
Nx	23.5	26	30	33.5	39.5	45	52.5	60
Ny	8	9	11	12	15	16	18.5	22.5
Q	7.5	9.5	9.5	11	11	14	17.5	20
R	4.5	5.5	5.5	6.8	6.8	9	11	14
S	16	14	15.5	13	15.5	17.5	16.5	17.5
T	15	19	21	24	28	33	37	46
U	6	8	10	11	13	16	19	22
V	6	8	9	10	12	14	16	21
W	7.5	9.5	10.5	12	14	17	19	23
倒角 Chamfer	C2	C3	C3	C3	C4	C5	C6	C6
AB	12	15	17	19	22	27	32	42
AC	6 <sup>+0.012</sup> <sub>0</sub>	8 <sup>+0.015</sup> <sub>0</sub>	8 <sup>+0.015</sup> <sub>0</sub>	10 <sup>+0.015</sup> <sub>0</sub>	12 <sup>+0.018</sup> <sub>0</sub>	14 <sup>+0.018</sup> <sub>0</sub>	16 <sup>+0.018</sup> <sub>0</sub>	20 <sup>+0.021</sup> <sub>0</sub>
AD	6	8	9	10	12	14	16	21
AE	-	-	6	4	6	6	8	10
AF	-	-	M4×0.7	M5×0.8	M5×0.8	M6	M6	M6
DA	3.5	3.5	3.5	3.5	4.5	4.5	4.5	4.5
DB	14	14	14	14	19	19	22	22
排气口 Air Bleed Port	-C型	G1/8	G1/8	G1/8	G1/8	G1/4	G1/4	G3/8
供油口 Hydraulic Port	-S型	RC1/8	RC1/8	RC1/8	RC1/8	RC1/4	RC1/4	RC3/8
O型密封圈 O-ring	1BP5	1BP5	1BP5	1BP5	1BP7	1BP7	1BP7	1BP7

### B:内螺纹型(附带旋转防止销孔)

Female Threaded with Anti-Rotation Pin Hole

Unit:mm

型号 Model	CLL-036	CLL-040	CLL-048	CLL-055	CLL-065	CLL-075	CLL-090	CLL-105
VB	2	2.5	2.5	2.5	3	4	5	6
WB	5.5	5	6	6.5	7	8.5	9	10.5

无记载的尺寸请参考P: 销孔连接型 A: 内螺纹型  
 Refer P pinhole option / A female thread option, dimensions not mentioned size in the chart below

### T:外螺纹型 Male Threaded

Unit:mm

型号 Model	CLL-036	CLL-040	CLL-048	CLL-055	CLL-065	CLL-075	CLL-090	CLL-105
AT	73 Y+58	81 Y+66	88 Y+73	96 Y+81	107 Y+92	118 Y+103	139 Y+124	153 Y+138
TT	25	30	35	40	45	50	62	72
UT	12	14	17	17	19	24	30	36
VT	16	20	24	28	32	35	46	54
WT	7.5	7.5	8.5	9	10	12	13	15
CB	14	17	19	21	24	29	34.5	42
CC (名称x螺距) (Nominal x Pitch)	M10×1.25	M12×1.25	M14×1.5	M16×1.5	M20×1.5	M24×1.5	M30×1.5	M36×1.5

无记载的尺寸请参考P: 销孔连接型  
 Refer P pinhole option dimension for not mentioned size below.

C板式连接型(配有G螺纹堵头) C. Gasket Option(with G Thread Plug)  
P:销孔连接型 CLL-CP型P: Pin-Hole Option ※ This drawing indicates CLL-CP

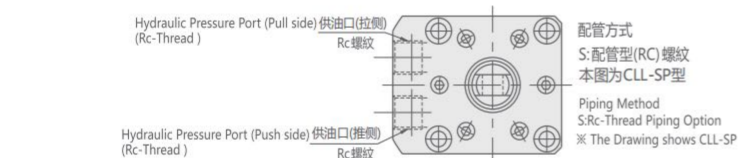
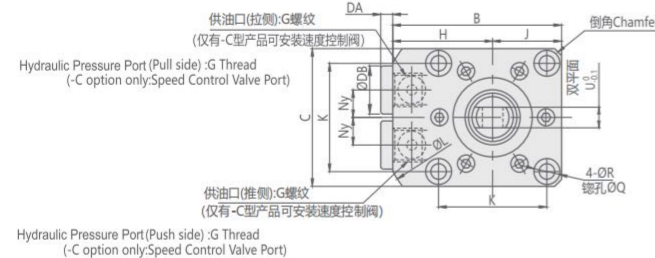
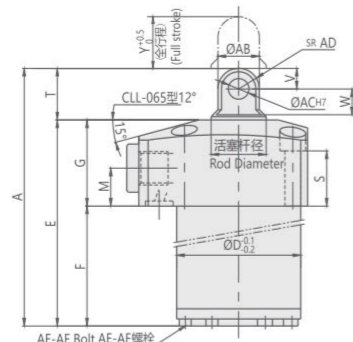
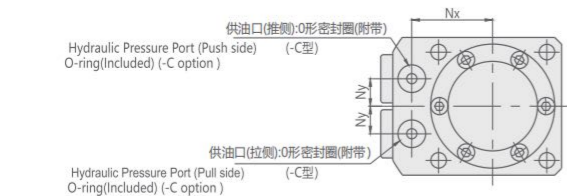

Tip Shape Refer P Pinhole dimension for not mentioned size below  
柱塞前端形状 无记载的尺寸请参考销孔连接型

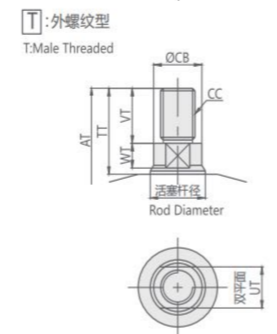
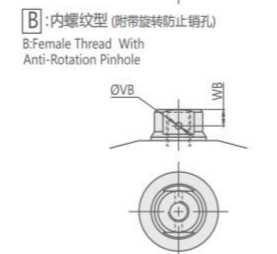
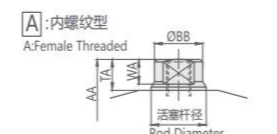

## 规格参数表 SPECIFICATIONS

型号	总行程	油缸面积		油缸出力		油缸容量(计算公式)		油缸内径	活塞杆径	最高使用压力	最低动作压力	耐压	使用温度	重量
MODEL	Full Stroke Y (mm)	推侧	拉侧	推侧	拉侧	推侧	拉侧	Cylinder inside diameter (mm)	Rod Diameter(mm)	Operating Pressure(Mpa) Max.	Operating Pressure(Mpa) Min.	Withstanding Pressure(Mpa)	Operating Temperature (°C)	Weight (kg)
CLL-036	51~100	4.5	2.5	P×0.45	P×0.25	Y×0.45	Y×0.25	Φ24	Φ16	7.0	0.5	10.5	0~70	0.9~1.2
CLL-040	51~100	5.3	2.8	P×0.53	P×0.28	Y×0.53	Y×0.28	Φ26	Φ18	7.0	0.5	10.5	0~70	1.0~1.4
CLL-048	76~200	8.0	4.9	P×0.80	P×0.49	Y×0.80	Y×0.49	Φ32	Φ20	7.0	0.5	10.5	0~70	1.7~3.0
CLL-055	76~200	9.6	5.8	P×0.96	P×0.58	Y×0.96	Y×0.58	Φ35	Φ22	7.0	0.5	10.5	0~70	2.3~4.1
CLL-065	76~200	15.9	11.0	P×1.59	P×1.10	Y×1.59	Y×1.10	Φ45	Φ25	7.0	0.5	10.5	0~70	3.2~5.4
CLL-075	76~200	23.8	16.7	P×2.38	P×1.67	Y×2.38	Y×1.67	Φ55	Φ30	7.0	0.5	10.5	0~70	4.4~7.1
CLL-090	76~200	36.3	26.4	P×3.63	P×2.64	Y×3.63	Y×2.64	Φ68	Φ35.5	7.0	0.5	10.5	0~70	6.5~10.1
CLL-105	76~200	50.3	34.4	P×5.03	P×3.44	Y×5.03	Y×3.44	Φ80	Φ45	7.0	0.5	10.5	0~70	9.0~13.0

### A:内螺纹型 Female Threaded

Unit:mm

型号 Model	CLL-036	CLL-040	CLL-048	CLL-055	CLL-065	CLL-075	CLL-090	CLL-105
AA	Y+57	Y+61	Y+66	Y+69	Y+76	Y+89	Y+100	Y+110
TA	9	10	11	12	13	15	16	18
UA	12	13	14	17	19	24	30	36
WA	7.5	7.5	8.5	9	10	12	13	15
BB	14	15	17	19	22	27	33	42
BC (名称×深度) (Nominal×Depth)	M6×12	M8×16	M8×16	M10×20	M12×24	M16×32	M20×40	M24×48

无记载的尺寸请参考P:销孔连接型  
Refer P pinhole option dimension for not mentioned size below.

### P:销孔连接型 Pin-Hole Option

Unit:mm

型号 Model	CLL-036	CLL-040	CLL-048	CLL-055	CLL-065	CLL-075	CLL-090	CLL-105
全行程 Full Stroke Y	51~100	51~100	76~200	76~200	76~200	76~200	76~200	76~200
A	Y+63	Y+70	Y+76	Y+81	Y+91	Y+107	Y+121	Y+138
B	49	54	61	69	81	92	107	122
C	40	45	51	60	70	80	95	110
D	36	40	48	55	65	75	90	105
E	Y+48	Y+51	Y+55	Y+57	Y+63	Y+74	Y+84	Y+92
F	Y+23	Y+26	Y+27	Y+29	Y+33	Y+37	Y+44	Y+47
G	25	25	28	28	30	37	40	45
H	29	31.5	35.5	39	46	52	59.5	67
J	20	22.5	25.5	30	35	40	47.5	55
K	31.4	34	40	47	55	63	75	88
L	66	73	83	88	106	116	136	152
M	11	11	12	12	13	16	16	17
Nx	23.5	26	30	33.5	39.5	45	52.5	60
Ny	8	9	11	12	15	16	18.5	22.5
Q	7.5	9.5	9.5	11	11	14	17.5	20
R	4.5	5.5	5.5	6.8	6.8	9	11	14
S	16	14	15.5	13	15.5	17.5	16.5	17.5
T	15	19	21	24	28	33	37	46
U	6	8	10	11	13	16	19	22
V	6	8	9	10	12	14	16	21
W	7.5	9.5	10.5	12	14	17	19	23
倒角 Chamfer	C2	C3	C3	C3	C4	C5	C6	C6
AB	12	15	17	19	22	32	42	42
AC	6 <sup>+0.012</sup> <sub>0</sub>	8 <sup>+0.015</sup> <sub>0</sub>	8 <sup>+0.015</sup> <sub>0</sub>	10 <sup>+0.015</sup> <sub>0</sub>	12 <sup>+0.018</sup> <sub>0</sub>	14 <sup>+0.018</sup> <sub>0</sub>	16 <sup>+0.018</sup> <sub>0</sub>	20 <sup>+0.021</sup> <sub>0</sub>
AD	6	8	9	10	12	14	16	21
AE	-	-	6	4	6	6	8	10
AF	-	-	M4×0.7	M5×0.8	M5×0.8	M6	M6	M6
DA	3.5	3.5	3.5	3.5	4.5	4.5	4.5	4.5
DB	14	14	14	14	19	19	22	22
排气口 Air Bleed Port	-C型	G1/8	G1/8	G1/8	G1/8	G1/4	G1/4	G3/8
供油口 Hydraulic Port	-S型	RC1/8	RC1/8	RC1/8	RC1/8	RC1/4	RC1/4	RC3/8
O型密封圈 O-ring	1BP5	1BP5	1BP5	1BP5	1BP7	1BP7	1BP7	1BP7

### B:内螺纹型 (附带旋转防止销孔)

型号 Model	CLL-036	CLL-040	CLL-048	CLL-055	CLL-065	CLL-075	CLL-090	CLL-105
VB	2	2.5	2.5	2.5	3	4	5	6
WB	5.5	5	6	6.5	7	8.5	9	10.5

无记载的尺寸请参考P:销孔连接型 A:内螺纹型  
Refer P pinhole option / A female thread option, dimensions not mentioned size in the chart below

### T:外螺纹型 Male Threaded

Unit:mm

型号 Model	CLL-036	CLL-040	CLL-048	CLL-055	CLL-065	CLL-075	CLL-090	CLL-105
AT	Y+73	Y+81	Y+90	Y+97	Y+108	Y+124	Y+146	Y+164
TT	25	30	35	40	45	50	62	72
UT	12	14	17	17	19	24	30	36
VT	16	20	24	28	32	35	46	54
WT	7.5	7.5	8.5	9	10	12	13	15
CB	14	17	19	21	24	29	34.5	42
CC (名称×螺距) (Nominal×Pitch)	M10×1.25	M12×1.25	M14×1.5	M16×1.5	M20×1.5	M24×1.5	M30×1.5	M36×1.5

无记载的尺寸请参考P:销孔连接型  
Refer P pinhole option dimension for not mentioned size below.

C:板式连接型(配有G螺纹堵头) C: Gasket Option(with G Thread Plug)  
P:销孔连接型 本图表示 CLLR-CP 型: Pin-Hole Option※ This drawing indicates CLLR-CP

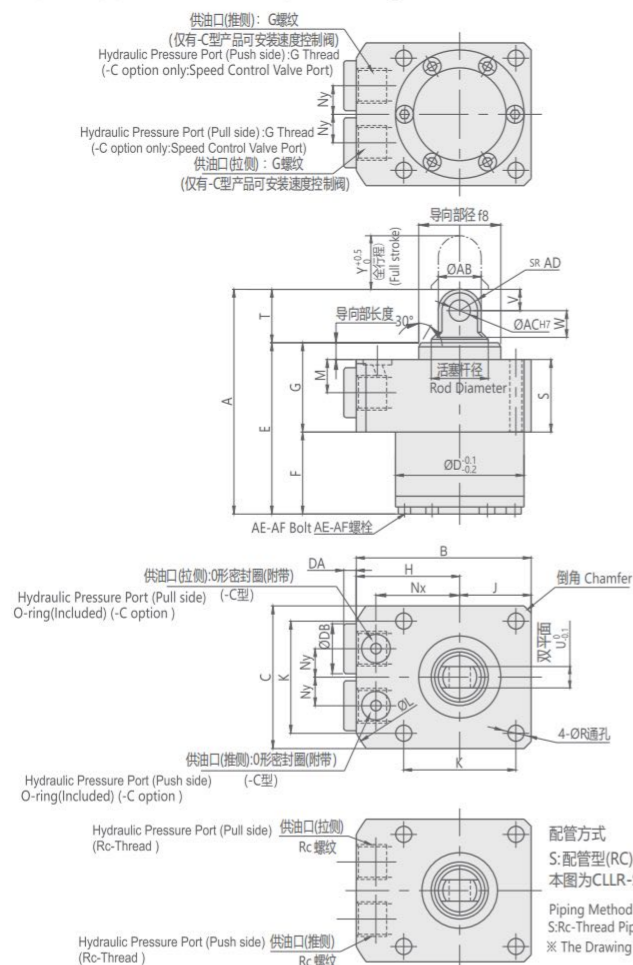

Tip Shape Refer P Pinhole dimension for not mentioned size below  
柱塞前端形状 无记载的尺寸请参照销孔连接型

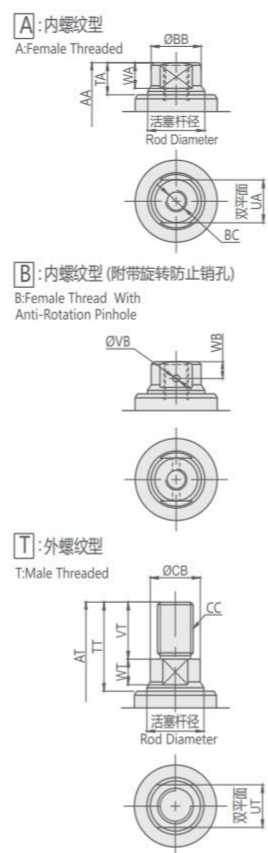

**规格参数表 SPECIFICATIONS**

型号	总行程	油缸面积		油缸输出力		油缸容量 (计算公式)		油缸内径	活塞杆径	最高使用压力	最低动作压力	耐压	使用温度	重量
MODEL	Full Stroke Y (mm)	推侧	拉侧	推侧	拉侧	推侧	拉侧	Cylinder inside diameter (mm)	Rod Diameter(mm)	Operating Pressure(Mpa)	Operating Pressure(Mpa)	Withstanding Pressure(Mpa)	Operating Temperature (°C)	Weight (kg)
CLLR-036	1~50	4.5	2.5	P×0.45	P×0.25	Y×0.45	Y×0.25	Φ24	Φ16	7.0	0.5	10.5	0~70	0.6~0.8
CLLR-040	1~50	5.3	2.8	P×0.53	P×0.28	Y×0.53	Y×0.28	Φ26	Φ18	7.0	0.5	10.5	0~70	0.7~0.9
CLLR-048	1~75	8.0	4.9	P×0.80	P×0.49	Y×0.80	Y×0.49	Φ32	Φ20	7.0	0.5	10.5	0~70	1.0~1.6
CLLR-055	1~75	9.6	5.8	P×0.96	P×0.58	Y×0.96	Y×0.58	Φ35	Φ22	7.0	0.5	10.5	0~70	1.3~2.1
CLLR-065	1~75	15.9	11.0	P×1.59	P×1.10	Y×1.59	Y×1.10	Φ45	Φ25	7.0	0.5	10.5	0~70	1.9~3.1
CLLR-075	1~75	23.8	16.7	P×2.38	P×1.67	Y×2.38	Y×1.67	Φ55	Φ30	7.0	0.5	10.5	0~70	2.8~4.1
CLLR-090	1~75	36.3	26.4	P×3.63	P×2.64	Y×3.63	Y×2.64	Φ68	Φ35.5	7.0	0.5	10.5	0~70	4.3~6.1
CLLR-105	1~75	50.3	34.4	P×5.03	P×3.44	Y×5.03	Y×3.44	Φ80	Φ45	7.0	0.5	10.5	0~70	5.9~8.0

**A:内螺纹型 Female Threaded**

Unit:mm

型号 Model	CLLR-036	CLLR-040	CLLR-048	CLLR-055	CLLR-065	CLLR-075	CLLR-090	CLLR-105
AA	57 Y+42	61 Y+46	64 Y+49	68 Y+53	75 Y+60	83 Y+68	93 Y+78	99 Y+84
TA	9	10	11	12	13	15	16	18
UA	12	13	14	17	19	24	30	36
WA	7.5	7.5	8.5	9	10	12	13	15
BB	14	15	17	19	22	27	33	42
BC (名称×深度) (Nominal×Depth)	M6×12	M8×16	M8×16	M10×20	M12×24	M16×32	M20×40	M24×48

无记载的尺寸请参照P:销孔连接型

Refer P pinhole option dimension for not mentioned size below.

全行程Y=1~14mm时,外形尺寸与行程15mm时的油缸是一样的(例)  
CLLR-036□P-010 [Y=10, A=63, E=48, F=23] CLLR-036□P-030 [Y=30, A=78, E=63, F=38]

※ Calculation formula is different between full stroke: Y=1-14 mm and Y= more than 15 mm.Ex) CLLR-036□P-010 [Y=10, A=63, E=48, F=23] CLLR-036□P-030 [Y=30, A=78, E=63, F=38]

**P:销孔连接型 Pin-Hole Option**

Unit:mm

型号 Model	CLLR-036	CLLR-040	CLLR-048	CLLR-055	CLLR-065	CLLR-075	CLLR-090	CLLR-105
全行程 Full Stroke Y	1~14 15~50	1~14 15~50	1~14 15~75	1~14 15~75	1~14 15~75	1~14 15~75	1~14 15~75	1~14 15~75
A	63 Y+48	70 Y+55	74 Y+59	80 Y+65	90 Y+75	101 Y+86	114 Y+99	127 Y+112
B	49	55	62	69	81	93	108	122
C	40	47	53	60	70	82	97	110
D	36	40	48	55	65	75	90	105
E	48 Y+33	51 Y+36	53 Y+38	56 Y+41	62 Y+47	68 Y+53	77 Y+62	81 Y+66
F	23 Y+8	26 Y+11	25 Y+10	28 Y+13	32 Y+17	31 Y+16	37 Y+22	36 Y+21
G	25	25	28	28	30	37	40	45
H	29	31.5	35.5	39	46	52	59.5	67
J	20	23.5	26.5	30	35	41	48.5	55
K	31.4	36	41	47	55	64	76	88
L	66	73	83	88	106	116	136	152
M	11	11	12	12	13	16	16	17
Nx	23.5	26	30	33.5	39.5	45	52.5	60
Ny	8	9	11	12	15	16	18.5	22.5
R	4.5	5.5	5.5	6.8	6.8	9	11	14
S	21	21	24	24	26	32	35	39
导向径 The Diameter of Mating Fit	23 <sup>-0.02</sup> <sub>-0.05</sub>	25 <sup>-0.02</sup> <sub>-0.05</sub>	28 <sup>-0.02</sup> <sub>-0.05</sub>	32 <sup>-0.025</sup> <sub>-0.064</sub>	38 <sup>-0.025</sup> <sub>-0.064</sub>	44 <sup>-0.025</sup> <sub>-0.064</sub>	50 <sup>-0.025</sup> <sub>-0.064</sub>	60 <sup>-0.030</sup> <sub>-0.076</sub>
导向长度 The Length Of Mating Fit	4	4	4	4	4	5	5	6
T	15	19	21	24	28	33	37	46
U	6	8	10	11	13	16	19	22
V	6	8	9	10	12	14	16	21
W	7.5	9.5	10.5	12	14	17	19	23
倒角 Chamfer	C2	C2	C3	C3	C4	C5	C6	C6
AB	12	15	17	19	22	27	32	42
AC	6 <sup>+0.012</sup> <sub>0</sub>	8 <sup>+0.015</sup> <sub>0</sub>	8 <sup>+0.015</sup> <sub>0</sub>	10 <sup>+0.015</sup> <sub>0</sub>	12 <sup>+0.018</sup> <sub>0</sub>	14 <sup>+0.018</sup> <sub>0</sub>	16 <sup>+0.018</sup> <sub>0</sub>	20 <sup>+0.021</sup> <sub>0</sub>
AD	6	8	9	10	12	14	16	21
AE	-	-	6	4	6	6	8	10
AF	-	-	M4×0.7	M5×0.8	M5×0.8	M6	M6	M6
DA	3.5	3.5	3.5	3.5	4.5	4.5	4.5	4.5
DB	14	14	14	14	19	19	22	22
排气口 Air Bleed Port	-C型	G1/8	G1/8	G1/8	G1/4	G1/4	G3/8	G3/8
供油口 Hydraulic Port	-S型	RC1/8	RC1/8	RC1/8	RC1/4	RC1/4	RC3/8	RC3/8
O型密封圈 O-ring	1BP5	1BP5	1BP5	1BP5	1BP7	1BP7	1BP7	1BP7

**B:内螺纹型(附带旋转防止销孔) Female Threaded with Anti-Rotation Pin Hole**

Unit:mm

型号 Model	CLLR-036	CLLR-040	CLLR-048	CLLR-055	CLLR-065	CLLR-075	CLLR-090	CLLR-105
VB	2	2.5	2.5	2.5	3	4	5	6
WB	5.5	5	6	6.5	7	8.5	9	10.5

无记载的尺寸请参照P:销孔连接型 A:内螺纹型

Refer P pinhole option / A female thread option, dimensions not mentioned size in the chart below

**T:外螺纹型 Male Threaded**

Unit:mm

型号 Model	CLLR-036	CLLR-040	CLLR-048	CLLR-055	CLLR-065	CLLR-075	CLLR-090	CLLR-105
AT	73 Y+58	81 Y+66	88 Y+73	96 Y+81	107 Y+92	118 Y+103	139 Y+124	153 Y+138
TT	25	30	35	40	45	50	62	72
UT	12	14	17	17	19	24	30	36
VT	16	20	24	28	32	35	46	54
WT	7.5	7.5	8.5	9	10	12	13	15
CB	14	17	19	21	24	29	34.5	42
CC (名称×螺距) (Nominal×Pitch)	M10×1.25	M12×1.25	M14×1.5	M16×1.5	M20×1.5	M24×1.5	M30×1.5	M36×1.5

无记载的尺寸请参照P:销孔连接型

Refer P pinhole option dimension for not mentioned size below.

C:板式连接型(配有G螺纹堵头) C: Gasket Option(with G Thread Plug)  
 P:销孔连接型 本图表示 CLLR-CP 型P: Pin-Hole Option ※ This drawing indicates CLLR-CP

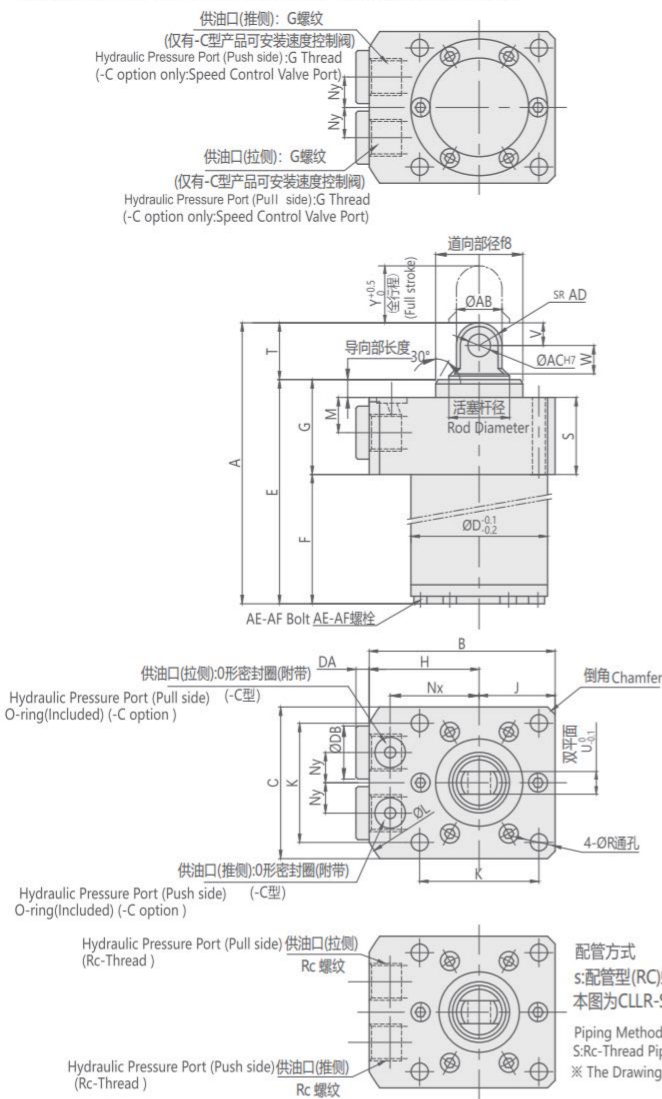

Tip Shape Refer P Pinhole dimension for not mentioned size below  
 柱塞前端形状 无记载的尺寸参照销孔连接型

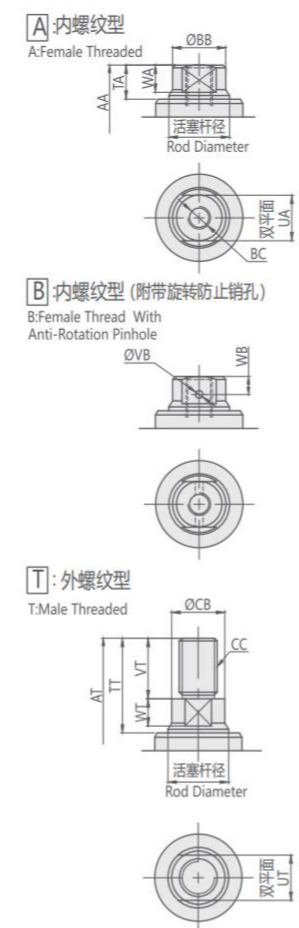

### 规格参数表 SPECIFICATIONS

型号	总行程	油缸面积		油缸出力		油缸容量 (计算公司)		油缸内径	活塞杆径	最高使用压力	最低动作压力	耐压	使用温度	重量
MODEL	Full Stroke Y (mm)	推侧 Push Side	拉侧 Pull Side	推侧 Push Side	拉侧 Pull Side	推侧 Push Side	拉侧 Pull Side	Cylinder inside diameter (mm)	Rod Diameter(mm)	Operating Pressure(Mpa)	Operating Pressure(Mpa)	Withstanding Pressure(Mpa)	Operating Temperature (°C)	Weight (kg)
CLLR-048	Y: 76~150	8.0	4.9	P×0.80	P×0.49	Y×0.80	Y×0.49	Φ32	Φ20	7.0	0.5	10.5	0~70	1.7~2.3
CLLR-055	Y: 76~150	9.6	5.8	P×0.96	P×0.58	Y×0.96	Y×0.58	Φ35	Φ22	7.0	0.5	10.5	0~70	2.3~3.1
CLLR-065	Y: 76~150	15.9	11.0	P×1.59	P×1.10	Y×1.59	Y×1.10	Φ45	Φ25	7.0	0.5	10.5	0~70	3.2~4.1
CLLR-075	Y: 76~150	23.8	16.7	P×2.38	P×1.67	Y×2.38	Y×1.67	Φ55	Φ30	7.0	0.5	10.5	0~70	4.4~5.3
CLLR-090	Y: 76~150	36.3	26.4	P×3.63	P×2.64	Y×3.63	Y×2.64	Φ68	Φ35.5	7.0	0.5	10.5	0~70	6.5~7.6
CLLR-105	Y: 76~150	50.3	34.4	P×5.03	P×3.44	Y×5.03	Y×3.44	Φ80	Φ45	7.0	0.5	10.5	0~70	9.0~9.8

### A:内螺纹型 Female Threaded

Unit:mm

型号 Model	CLLR-048	CLLR-055	CLLR-065	CLLR-075	CLLR-090	CLLR-105
AA	Y+66	Y+69	Y+76	Y+89	Y+100	Y+110
TA	11	12	13	15	16	18
UA	14	17	19	24	30	36
WA	8.5	9	10	12	13	15
BB	17	19	22	27	33	42
BC (名称×深度) (Nominal×Depth)	M8×16	M10×20	M12×24	M16×32	M20×40	M24×48

无记载的尺寸请参照P: 销孔连接型  
 Refer P pinhole option dimension for not mentioned size below.

### P:销孔连接型 Pin-Hole Option

Unit:mm

型号 Model	CLLR-048	CLLR-055	CLLR-065	CLLR-075	CLLR-090	CLLR-105
全行程 Full Stroke Y	76~150	76~150	76~150	76~150	76~150	76~150
A	Y+76	Y+81	Y+91	Y+107	Y+121	Y+138
B	62	69	81	93	108	122
C	53	60	70	82	97	110
D	48	55	65	75	90	105
E	Y+55	Y+57	Y+63	Y+74	Y+84	Y+92
F	Y+27	Y+29	Y+33	Y+37	Y+44	Y+47
G	28	28	30	37	40	45
H	35.5	39	46	52	59.5	67
J	26.5	30	35	41	48.5	55
K	41	47	55	64	76	88
L	83	88	106	116	136	152
M	12	12	13	16	16	17
Nx	30	33.5	39.5	45	52.5	60
Ny	11	12	15	16	18.5	22.5
R	5.5	6.8	6.8	9	11	14
S	24	24	26	32	35	39
导向孔径 The Diameter of Mating Fit	28 <sup>-0.020</sup> <sub>-0.053</sub>	32 <sup>-0.025</sup> <sub>-0.064</sub>	38 <sup>-0.025</sup> <sub>-0.064</sub>	44 <sup>-0.025</sup> <sub>-0.064</sub>	50 <sup>-0.025</sup> <sub>-0.064</sub>	60 <sup>-0.030</sup> <sub>-0.076</sub>
导向长度 The Length Of Mating Fit	4	4	4	5	5	6
T	21	24	28	33	37	46
U	10	11	13	16	19	22
V	9	10	12	14	16	21
W	10.5	12	14	17	19	23
倒角 Chamfer	C3	C3	C4	C5	C6	C6
AB	17	19	22	27	32	42
AC	8 <sup>+0.015</sup> <sub>0</sub>	10 <sup>+0.018</sup> <sub>0</sub>	12 <sup>+0.018</sup> <sub>0</sub>	14 <sup>+0.018</sup> <sub>0</sub>	16 <sup>+0.018</sup> <sub>0</sub>	20 <sup>+0.021</sup> <sub>0</sub>
AD	9	10	12	14	16	21
AE	6	4	6	6	8	10
AF	M4×0.7	M5×0.8	M5×0.8	M6	M6	M6
DA	3.5	3.5	4.5	4.5	4.5	4.5
DB	14	14	19	19	22	22
排气口 Air Bleed Port	-C型 G1/8	G1/8	G1/4	G1/4	G3/8	G3/8
供油口 Hydraulic Port	-S型 RC1/8	RC1/8	RC1/4	RC1/4	RC3/8	RC3/8
O型密封圈 O-ring	1BP5	1BP5	1BP7	1BP7	1BP7	1BP7

### B:内螺纹型 (附带旋转防止销孔) Female Threaded with Anti-Rotation Pin Hole

Unit:mm

型号 Model	CLLR-048	CLLR-055	CLLR-065	CLLR-075	CLLR-090	CLLR-105
VB	2.5	2.5	3	4	5	6
WB	6	6.5	7	8.5	9	10.5

无记载的尺寸请参照P: 销孔连接型 A:内螺纹型  
 Refer P pinhole option / A female thread option, dimensions not mentioned size in the chart below

### T:外螺纹型 Male Threaded

Unit:mm

型号 Model	CLLR-048	CLLR-055	CLLR-065	CLLR-075	CLLR-090	CLLR-105
AT	Y+90	Y+97	Y+108	Y+124	Y+146	Y+164
TT	35	40	45	50	62	72
UT	17	17	19	24	30	36
VT	24	28	32	35	46	54
WT	8.5	9	10	12	13	15
CB	19	21	24	29	34.5	42
CC (名称×螺距) (Nominal×Pitch)	M14×1.5	M16×1.5	M20×1.5	M24×1.5	M30×1.5	M36×1.5

无记载的尺寸请参照P: 销孔连接型  
 Refer P pinhole option dimension for not mentioned size below.

C:板式连接型 P:销孔连接型 G: Gasket Option P:Pin-Hole Option  
 ※本图表示CLLU-GP型 ※ This drawing indicates CLLU-GP

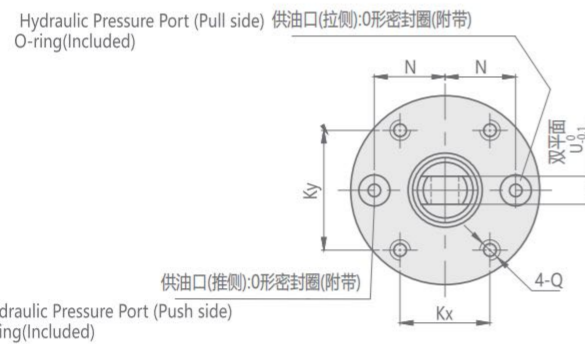
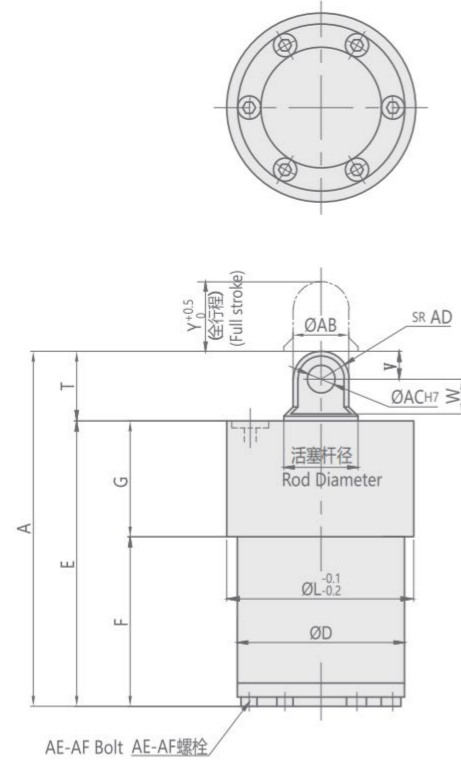

Tip Shape Refer P Pinhole dimension for not mentioned size below  
 柱塞前端形状 无记载的尺寸请参照销孔连接型

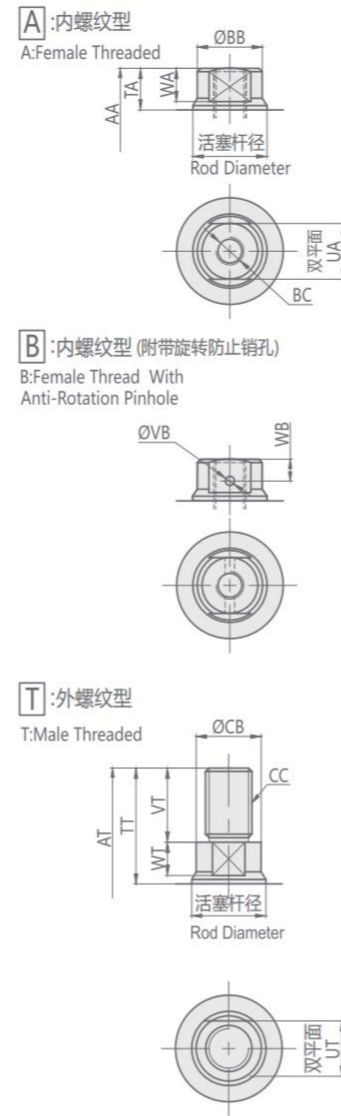

规格参数表 SPECIFICATIONS

型号	总行程	油缸面积		油缸输出力		油缸容量 (计算公式)		油缸内径	活塞杆径	最高使用压力	最低动作压力	耐压	使用温度	重量
MODEL	Full Stroke Y (mm)	推侧	拉侧	推侧	拉侧	推侧	拉侧	Cylinder inside diameter (mm)	Rod Diameter(mm)	Operating Pressure(Mpa)	Operating Pressure(Mpa)	Withstanding Pressure(Mpa)	Operating Temperature (°C)	Weight (kg)
CLLU-036	1~50	4.5	2.5	P×0.45	P×0.25	Y×0.45	Y×0.25	Φ24	Φ16	7.0	0.5	10.5	0~70	0.6~0.8
CLLU-040	1~50	5.3	2.8	P×0.53	P×0.28	Y×0.53	Y×0.28	Φ26	Φ18	7.0	0.5	10.5	0~70	0.7~0.9
CLLU-048	1~75	8.0	4.9	P×0.80	P×0.49	Y×0.80	Y×0.49	Φ32	Φ20	7.0	0.5	10.5	0~70	1.0~1.6
CLLU-055	1~75	9.6	5.8	P×0.96	P×0.58	Y×0.96	Y×0.58	Φ35	Φ22	7.0	0.5	10.5	0~70	1.3~2.1
CLLU-065	1~75	15.9	11.0	P×1.59	P×1.10	Y×1.59	Y×1.10	Φ45	Φ25	7.0	0.5	10.5	0~70	1.9~3.1
CLLU-075	1~75	23.8	16.7	P×2.38	P×1.67	Y×2.38	Y×1.67	Φ55	Φ30	7.0	0.5	10.5	0~70	2.8~4.1
CLLU-090	1~75	36.3	26.4	P×3.63	P×2.64	Y×3.63	Y×2.64	Φ68	Φ35.5	7.0	0.5	10.5	0~70	4.3~6.1
CLLU-105	1~75	50.3	34.4	P×5.03	P×3.44	Y×5.03	Y×3.44	Φ80	Φ45	7.0	0.5	10.5	0~70	5.9~8.0

全行程Y=1~14mm时, 外形尺寸与行程15mm时的油缸是一样的(例)  
 CLLU-036GP-010 [Y=10, A=63, E=48, F=23] CLLU-036GP-030 [Y=30, A=78, E=63, F=38]

※ Calculation formula is different between full stroke: Y=1-14 mm and Y= more than 15 mm.Ex) CLLU-036GP-010 [ Y=10, A=63, E=48, F=23 ] CLLU-036GP-030 [ Y=30, A=78, E=63, F=38 ]

P:销孔连接型 Pin-Hole Option

Unit:mm

型号 Model	CLLU-036	CLLU-040	CLLU-048	CLLU-055	CLLU-065	CLLU-075	CLLU-090	CLLU-105
全行程 Full Stroke Y	1~14 15~50	1~14 15~50	1~14 15~75	1~14 15~75	1~14 15~75	1~14 15~75	1~14 15~75	1~14 15~75
A	63 Y+48	70 Y+55	74 Y+59	80 Y+65	90 Y+75	101 Y+86	114 Y+99	127 Y+112
D	36	40	48	55	65	75	90	105
E	48 Y+33	51 Y+36	53 Y+38	56 Y+41	62 Y+47	68 Y+53	77 Y+62	81 Y+66
F	23 Y+8	26 Y+11	25 Y+10	28 Y+13	32 Y+17	31 Y+16	37 Y+22	36 Y+21
G	25	25	28	28	30	37	40	45
Kx	23	24	27	30	36	42	54	65
Ky	30	32	36	40	48	56	64	65
L	45	48	53	60	70	83	100	116
N	17	18	20	22.5	27.5	32.5	39.5	46
Q (名称×深度) (Nominal×Depth)	M4×0.7×8	M5×0.8×10	M5×0.8×10	M6×12	M6×12	M8×16	M10×20	M12×24
T	15	19	21	24	28	33	37	46
U	6	8	10	11	13	16	19	22
V	6	8	9	10	12	14	16	21
W	7.5	9.5	10.5	12	14	17	19	23
AB	12	15	17	19	22	27	32	42
AC	6 <sup>+0.012</sup> <sub>0</sub>	8 <sup>+0.015</sup> <sub>0</sub>	8 <sup>+0.015</sup> <sub>0</sub>	10 <sup>+0.015</sup> <sub>0</sub>	12 <sup>+0.018</sup> <sub>0</sub>	14 <sup>+0.018</sup> <sub>0</sub>	16 <sup>+0.018</sup> <sub>0</sub>	20 <sup>+0.021</sup> <sub>0</sub>
AD	6	8	9	10	12	14	16	21
AE	-	-	6	4	6	6	8	10
AF	-	-	M4×0.7	M5×0.8	M5×0.8	M6	M6	M6
O型密封圈 O-ring	1BP5	1BP5	1BP5	1BP5	1BP7	1BP7	1BP7	1BP7

A:内螺纹型 Female Threaded

Unit:mm

型号 Model	CLLU-036	CLLU-040	CLLU-048	CLLU-055	CLLU-065	CLLU-075	CLLU-090	CLLU-105
AA	57 Y+42	61 Y+46	64 Y+49	68 Y+53	75 Y+60	83 Y+68	93 Y+78	99 Y+84
TA	9	10	11	12	13	15	16	18
UA	12	13	14	17	19	24	30	36
WA	7.5	7.5	8.5	9	10	12	13	15
BB	14	15	17	19	22	27	33	42
BC (名称×深度) (Nominal×Depth)	M6×12	M8×16	M8×16	M10×20	M12×24	M16×32	M20×40	M24×48

无记载的尺寸请参照P: 销孔连接型  
 Refer P pinhole option dimension for not mentioned size below.

B:内螺纹型 (附带旋转防止销孔) Female Threaded with Anti-Rotation Pin Hole

Unit:mm

型号 Model	CLLU-036	CLLU-040	CLLU-048	CLLU-055	CLLU-065	CLLU-075	CLLU-090	CLLU-105
VB	2	2.5	2.5	2.5	3	4	5	6
WB	5.5	5	6	6.5	7	8.5	9	10.5

无记载的尺寸请参照P: 销孔连接型 A:内螺纹型  
 Refer P pinhole option / A female thread option, dimensions not mentioned size in the chart below

T:外螺纹型 Male Threaded

Unit:mm

型号 Model	CLLU-036	CLLU-040	CLLU-048	CLLU-055	CLLU-065	CLLU-075	CLLU-090	CLLU-105
AT	73 Y+58	81 Y+66	88 Y+73	96 Y+81	107 Y+92	118 Y+103	139 Y+124	153 Y+138
TT	25	30	35	40	45	50	62	72
UT	12	14	17	17	19	24	30	36
VT	16	20	24	28	32	35	46	54
WT	7.5	7.5	8.5	9	10	12	13	15
CB	14	17	19	21	24	29	34.5	42
CC (名称×螺距) (Nominal×Pitch)	M10×1.25	M12×1.25	M14×1.5	M16×1.5	M20×1.5	M24×1.5	M30×1.5	M36×1.5

无记载的尺寸请参照P: 销孔连接型  
 Refer P pinhole option dimension for not mentioned size below.

C:板式连接型 P:销孔连接型 G: Gasket Option P:Pin-Hole Option  
 ※本图表示CLLU-GP型※ This drawing indicates CLLU-GP

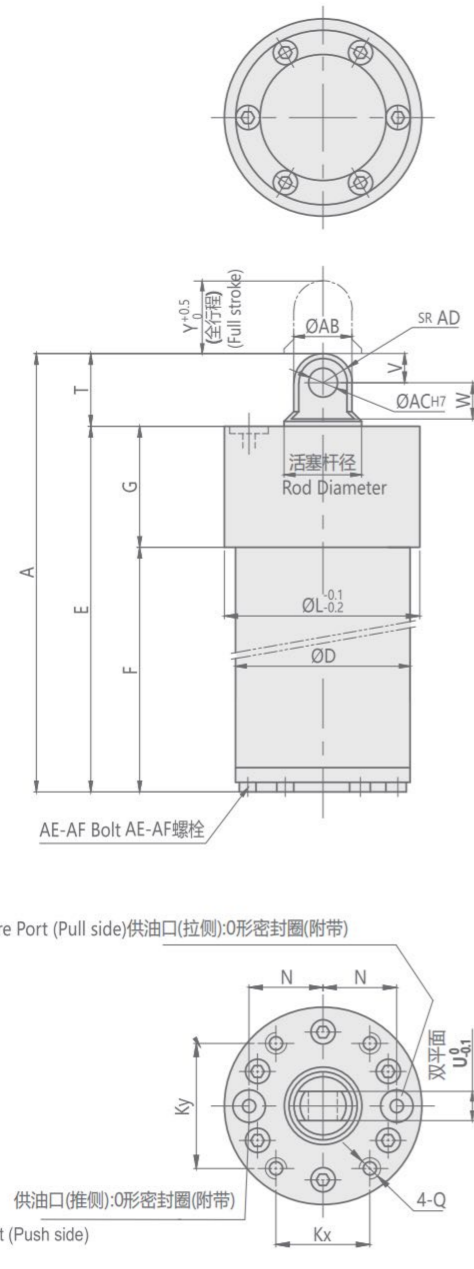

Tip Shape Refer P Pinhole dimension for not mentioned size below  
 柱塞前端形状 无记载的尺寸请参照销孔连接型

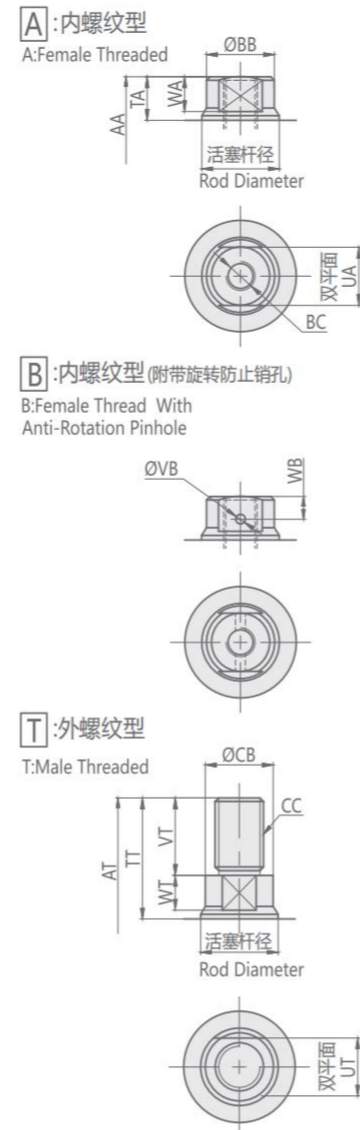

规格参数表 SPECIFICATIONS

型号 MODEL	总行程 Full Stroke Y (mm)	油缸面积 Cylinder Area(cm <sup>2</sup> )		油缸出力 Cylinder force (计算公式) (Calculation Formula) KN		油缸容量 (计算公式) Cylinder Capacity (Calculation Formula) cm <sup>3</sup>		油缸内径 Cylinder inside diameter (mm)	活塞杆径 Rod Diameter(mm)	最高使用压力 Max. Operating Pressure(Mpa)	最低动作压力 Min. Operating Pressure(Mpa)	耐压 Withstanding Pressure(Mpa)	使用温度 Operating Temperature (°C)	重量 Weight (kg)
		推侧 Push Side	拉侧 Pull Side	推侧 Push Side	拉侧 Pull Side	推侧 Push Side	拉侧 Pull Side							
CLLU-048	76~150	8.0	4.9	P×0.80	P×0.49	Y×0.80	Y×0.49	Φ32	Φ20	7.0	0.5	10.5	0~70	1.7~2.3
CLLU-055	76~150	9.6	5.8	P×0.96	P×0.58	Y×0.96	Y×0.58	Φ35	Φ22	7.0	0.5	10.5	0~70	2.3~3.1
CLLU-065	76~150	15.9	11.0	P×1.59	P×1.10	Y×1.59	Y×1.10	Φ45	Φ25	7.0	0.5	10.5	0~70	3.2~4.1
CLLU-075	76~150	23.8	16.7	P×2.38	P×1.67	Y×2.38	Y×1.67	Φ55	Φ30	7.0	0.5	10.5	0~70	4.4~5.3
CLLU-090	76~150	36.3	26.4	P×3.63	P×2.64	Y×3.63	Y×2.64	Φ68	Φ35.5	7.0	0.5	10.5	0~70	6.5~7.6
CLLU-105	76~150	50.3	34.4	P×5.03	P×3.44	Y×5.03	Y×3.44	Φ80	Φ45	7.0	0.5	10.5	0~70	9.0~9.8

P:销孔连接型 Pin-Hole Option

Unit:mm

型号 Model	CLLU-048	CLLU-055	CLLU-065	CLLU-075	CLLU-090	CLLU-105
全行程 Full Stroke Y	76~150	76~150	76~150	76~150	76~150	76~150
A	Y+76	Y+81	Y+91	Y+107	Y+121	Y+138
D	48	55	65	75	90	105
E	Y+55	Y+57	Y+63	Y+74	Y+84	Y+92
F	Y+27	Y+29	Y+33	Y+37	Y+44	Y+47
G	28	28	30	37	40	45
KX	27	30	36	42	54	65
KY	36	40	48	56	64	65
L	53	60	70	83	100	116
N	20	22.5	27.5	32.5	39.5	46
Q (名称×深度) (Nominal×Depth)	M5×0.8×10	M6×12	M6×12	M8×16	M10×20	M12×24
T	21	24	28	33	37	46
U	10	11	13	16	19	22
V	9	10	12	14	16	21
W	10.5	12	14	17	19	23
AB	17	19	22	27	32	42
AC	8 <sub>0</sub> <sup>+0.015</sup>	10 <sub>0</sub> <sup>+0.015</sup>	12 <sub>0</sub> <sup>+0.018</sup>	14 <sub>0</sub> <sup>+0.018</sup>	16 <sub>0</sub> <sup>+0.018</sup>	20 <sub>0</sub> <sup>+0.021</sup>
AD	9	10	12	14	16	21
AE	6	4	6	6	8	10
AF	M4×0.7	M5×0.8	M5×0.8	M6	M6	M6
O型密封圈 O-ring	1BP5	1BP5	1BP7	1BP7	1BP7	1BP7

A:内螺纹型 Female Threaded

Unit:mm

型号 Model	CLLU-048	CLLU-055	CLLU-065	CLLU-075	CLLU-090	CLLU-105
AA	Y+66	Y+69	Y+76	Y+89	Y+100	Y+110
TA	11	12	13	15	16	18
UA	14	17	19	24	30	36
WA	8.5	9	10	12	13	15
BB	17	19	22	27	33	42
BC (名称×深度) (Nominal×Depth)	M8×16	M10×20	M12×24	M16×32	M20×40	M24×48

无记载的尺寸请参照P: 销孔连接型  
 Refer P pinhole option dimension for not mentioned size below.

B:内螺纹型 (附带旋转防止销孔) Female Threaded with Anti-Rotation Pin Hole

Unit:mm

型号 Model	CLLU-048	CLLU-055	CLLU-065	CLLU-075	CLLU-090	CLLU-105
VB	2.5	2.5	3	4	5	6
WB	6	6.5	7	8.5	9	10.5

无记载的尺寸请参照P: 销孔连接型 A:内螺纹型  
 Refer P pinhole option / A female thread option, dimensions not mentioned size in the chart below

T:外螺纹型 Male Threaded

Unit:mm

型号 Model	CLLU-048	CLLU-055	CLLU-065	CLLU-075	CLLU-090	CLLU-105
AT	Y+90	Y+97	Y+108	Y+124	Y+146	Y+164
TT	35	40	45	50	62	72
UT	17	17	19	24	30	36
VT	24	28	32	35	46	54
WT	8.5	9	10	12	13	15
CB	19	21	24	29	34.5	42
CC (名称×螺距) (Nominal×Pitch)	M14×1.5	M16×1.5	M20×1.5	M24×1.5	M30×1.5	M36×1.5

无记载的尺寸请参照P: 销孔连接型  
 Refer P pinhole option dimension for not mentioned size below.

# CCNA

## 油压紧凑型直线缸

## CCNA HYDRAULIC COMPACT LINEAR CYLINDER



T:内螺纹型 Female Threaded

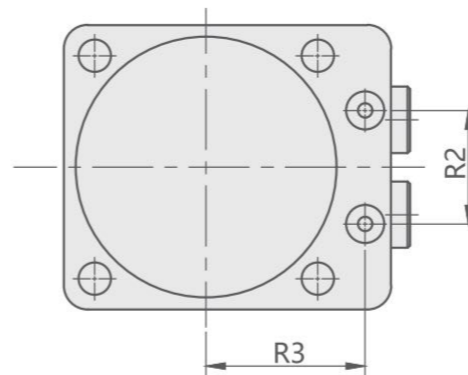

T:内螺纹型 Female Threaded

Unit:mm

型号 Model	CCNA02 -□T	CCNA04 -□T	CCNA06 -□T	CCNA10 -□T	CCNA16 -□T	CCNA25 -□T
B	45	50	57	70	86	108
C	55	60	66	82	96	120
D	32.5	35	37.5	47	53	66
E	22.5	25	28.5	35	43	54
F	35	40	46	56	68	88
ΦG	39	47	53	63	78	100
ΦH	16 <sup>-0.016</sup> <sub>-0.034</sub>	18 <sup>-0.016</sup> <sub>-0.034</sub>	22.4 <sup>-0.020</sup> <sub>-0.041</sub>	25 <sup>-0.020</sup> <sub>-0.041</sub>	30 <sup>-0.020</sup> <sub>-0.041</sub>	35.5 <sup>-0.025</sup> <sub>-0.050</sub>
J	38	39.5	42.5	51	57	65.5
L	27.5	28	30	37.5	41.5	48.5
M	10.5	11.5	12.5	13.5	15.5	17
N	M8×1.25	M8×1.25	M10×1.5	M12×1.75	M16×2.0	M20×2.5
P	14	14	18	21	27	33
R1	12.5	12.5	12.5	14	14	21
R2	22	24	28	36	45	50
R3	25	28	30.5	36	42	57
R4	20	22	26	30	38	50
S	7	8	9	10	12	14
ΦT	14±0.2	16±0.2	20±0.2	23±0.2	28±0.2	33.5±0.2
U	12	14	17	19	24	30
V	18	17	17	20	20	20
ΦW	5.5	5.5	6.8	9	11	14
ΦX	9.5	9.5	11	14	17.5	20
Y1	G1/8	G1/8	G1/8	G1/4	G1/4	G3/8
Z	R3	R5	R5	R6	R7	R10
O形圈	P7	P7	P7	P8	P8	P10
At 行程	10	66	70.5	74	88.5	96
	15	66	70.5	74	-	-
	20	81	85.5	89	88.5	96
	30	81	85.5	89	108.5	116
	40	101	105.5	109	108.5	116
	50	101	105.5	109	128.5	136
	60	121	125.5	129	128.5	136
	70	121	125.5	129	148.5	156
	80	-	-	149	148.5	156
	90	-	-	149	168.5	176
100	-	-	-	168.5	176	
110	-	-	-	-	195.5	
K 行程	10	28	31	31.5	37.5	39
	15	28	31	31.5	-	-
	20	43	46	46.5	37.5	39
	30	43	46	46.5	57.5	59
	40	63	66	66.5	57.5	59
	50	63	66	66.5	77.5	79
	60	83	86	86.5	77.5	79
	70	83	86	86.5	97.5	99
	80	-	-	106.5	97.5	99
	90	-	-	106.5	117.5	119
100	-	-	-	117.5	119	
110	-	-	-	-	130	

产品特性

以最小空间实现大的行程。

最大操作压力: 70 kgf/cm<sup>2</sup>  
 最小操作压力: 10 kgf/cm<sup>2</sup>  
 耐压: 105 kgf/cm<sup>2</sup>

FEATURES

Maximum stroke is available with minimum space

Max.operating pressure: 70kgf/cm<sup>2</sup>  
 Min.operating pressure: 10kgf/cm<sup>2</sup>  
 Withstanding pressure: 105kgf/cm<sup>2</sup>

订购标示法 ORDERING INDICATION

示例: CCNA02-10T

CCNA	系列 Series	CCNA
02	02/04/06/10/16/25	
10	行程 Stroke	CCNA02: 10/15/20/30/40/50/60/70 CCNA04: 10/15/20/30/40/50/60/70 CCNA06: 10/15/20/30/40/50/60/70/80/90 CCNA10: 10/20/30/40/50/60/70/80/90/100 CCNA16: 10/20/30/40/50/60/70/80/90/100 CCNA25: 20/30/40/50/60/70/80/90/100/110

T	活塞杆前端型式 Shape of Piston Tip	T:内螺纹型 Female Threaded P:销孔连接型 Pin-Hole Option M:外螺纹型 Male Threaded

规格参数表 SPECIFICATIONS

型号 MODEL	油缸面积 Cylinder Area(cm <sup>2</sup> )		油缸输出力 Cylinder force (Calculation Formula) KN		油缸容量 Cylinder Capacity (Calculation Formula) cm <sup>3</sup>		油缸内径 Cylinder inside diameter (mm)	活塞杆径 Rod Diameter(mm)	使用温度范围 Operating Temperature (°C)	使用流体 Usable Fluid
	推侧 Push Side	拉侧 Pull Side	推侧 Push Side	拉侧 Pull Side	推侧 Push Side	拉侧 Pull Side				
CCNA02	4.9	2.9	0.49xP	0.29xP	0.49xS	0.29xS	Φ25	Φ16	0~+70°C	相当于ISO黏度等级的ISO-VG-32一般液压油 Recommended: ISO-VG-32 hydraulic oil equivalent to ISO viscosity grade
CCNA04	7.1	4.5	0.71xP	0.45xP	0.71xS	0.45xS	Φ30	Φ16	0~+70°C	
CCNA06	9.6	5.7	0.96xP	0.57xP	0.96xS	0.57xS	Φ35	Φ22.4	0~+70°C	
CCNA10	15.2	10.3	1.52xP	1.03xP	1.52xS	1.03xS	Φ44	Φ25	0~+70°C	
CCNA16	24.6	17.6	2.46xP	1.76xP	2.46xS	1.76xS	Φ56	Φ30	0~+70°C	
CCNA25	38.5	28.6	3.85xP	2.86xP	3.85xS	2.86xS	Φ70	Φ35.5	0~+70°C	

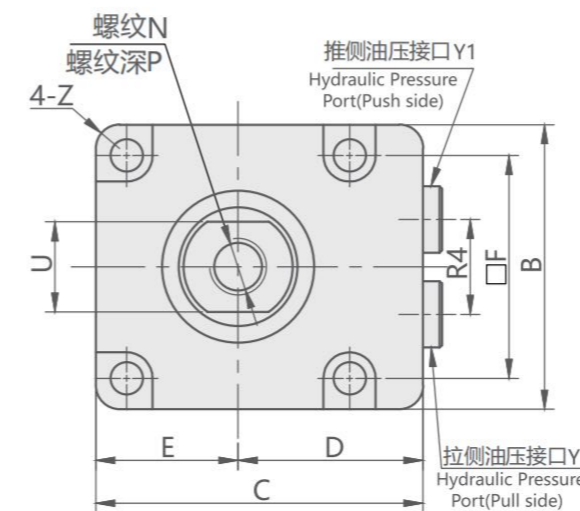
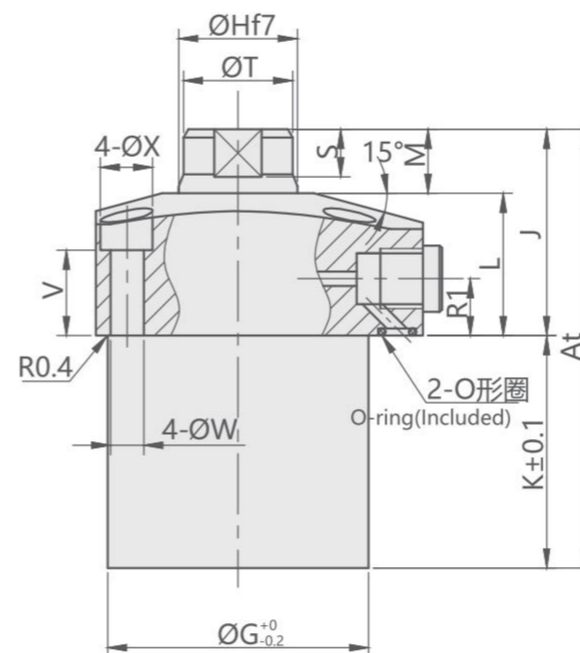

注:可选装CVCF调速阀

P:销孔连接型 Pin-Hole Option

P:销孔连接型 Pin-Hole Option

Unit:mm

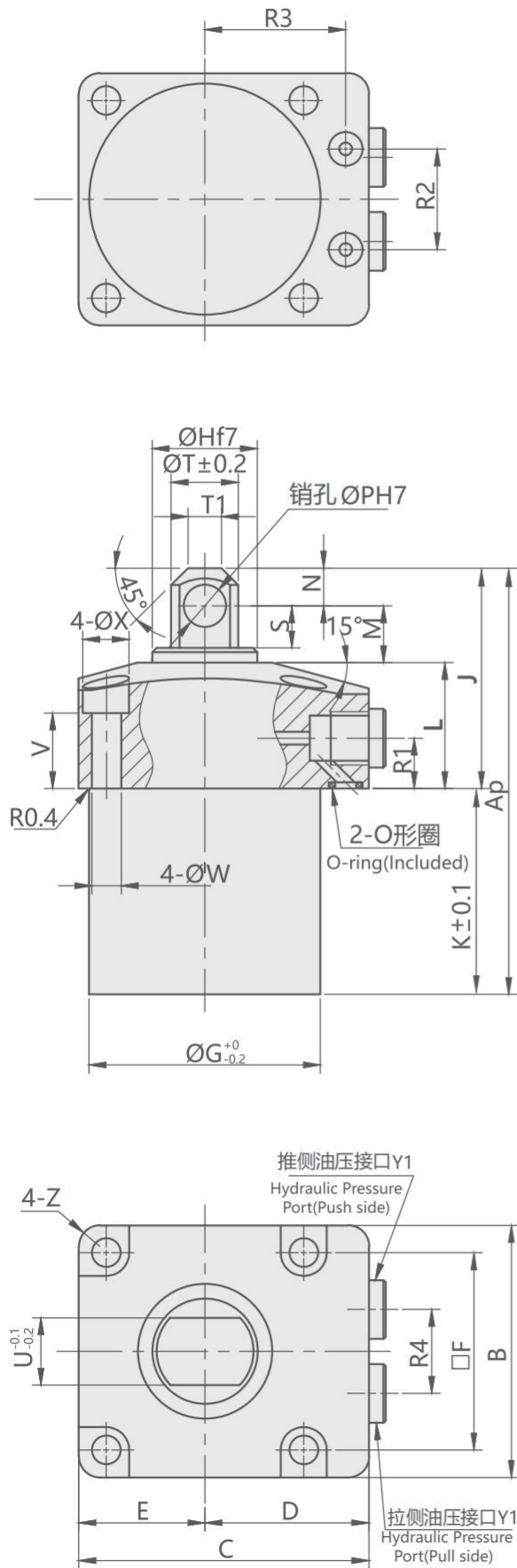

型号 Model	CCNA02 -□P	CCNA04 -□P	CCNA06 -□P	CCNA10 -□P	CCNA16 -□P	CCNA25 -□P
B	45	50	57	70	86	108
C	55	60	66	82	96	120
D	32.5	35	37.5	47	53	66
E	22.5	25	28.5	35	43	54
F	35	40	46	56	68	88
ΦG	39	47	53	63	78	100
ΦH	16 <sup>-0.016/-0.034</sup>	18 <sup>-0.016/-0.034</sup>	22.4 <sup>-0.020/-0.041</sup>	25 <sup>-0.020/-0.041</sup>	30 <sup>-0.020/-0.041</sup>	35.5 <sup>-0.025/-0.050</sup>
J	42.5	44.5	50.5	60	67	79.5
L	27.5	28	30	37.5	41.5	48.5
M	10	10.5	12.5	13.5	14.5	18
N	5	6	8	9	11	13
ΦP	6 <sup>-0.012/-0</sup>	6 <sup>-0.012/-0</sup>	8 <sup>-0.015/-0</sup>	10 <sup>-0.015/-0</sup>	12 <sup>-0.018/-0</sup>	14 <sup>-0.018/-0</sup>
R1	12.5	12.5	12.5	14	14	21
R2	22	24	28	36	45	50
R3	25	28	30.5	36	42	57
R4	20	22	26	30	38	50
S	6.5	7	9	10	10.8	14.5
ΦT	10	12	14	16	20	26
ΦT1	5	5	6	8	10	14
U	6	6	8	11	14	16
V	18	17	17	20	20	20
ΦW	5.5	5.5	6.8	9	11	14
ΦX	9.5	9.5	11	14	17.5	20
Y1	G1/8	G1/8	G1/8	G1/4	G1/4	G3/8
Z	R3	R5	R5	R6	R7	R10
O形圈	P7	P7	P7	P8	P8	P10
Ap 行程	10	70.5	75.5	82	97.5	106
	15	70.5	75.5	82	-	-
	20	85.5	90.5	97	97.5	106
	30	85.5	90.5	97	117.5	126
	40	105.5	110.5	117	117.5	126
	50	105.5	110.5	117	137.5	146
	60	125.5	130.5	137	137.5	146
	70	125.5	130.5	137	157.5	166
	80	-	-	157	157.5	166
	90	-	-	157	177.5	186
100	-	-	-	177.5	186	
110	-	-	-	-	209.5	
K 行程	10	28	31	31.5	37.5	39
	15	28	31	31.5	-	-
	20	43	46	46.5	37.5	39
	30	43	46	46.5	57.5	59
	40	63	66	66.5	57.5	59
	50	63	66	66.5	77.5	79
	60	83	86	86.5	77.5	79
	70	83	86	86.5	97.5	99
	80	-	-	106.5	97.5	99
	90	-	-	106.5	117.5	119
100	-	-	-	117.5	119	
110	-	-	-	-	130	

注:可选装CVCF调速阀

M:外螺纹型 Male Threaded

M:外螺纹型 Male Threaded

Unit:mm

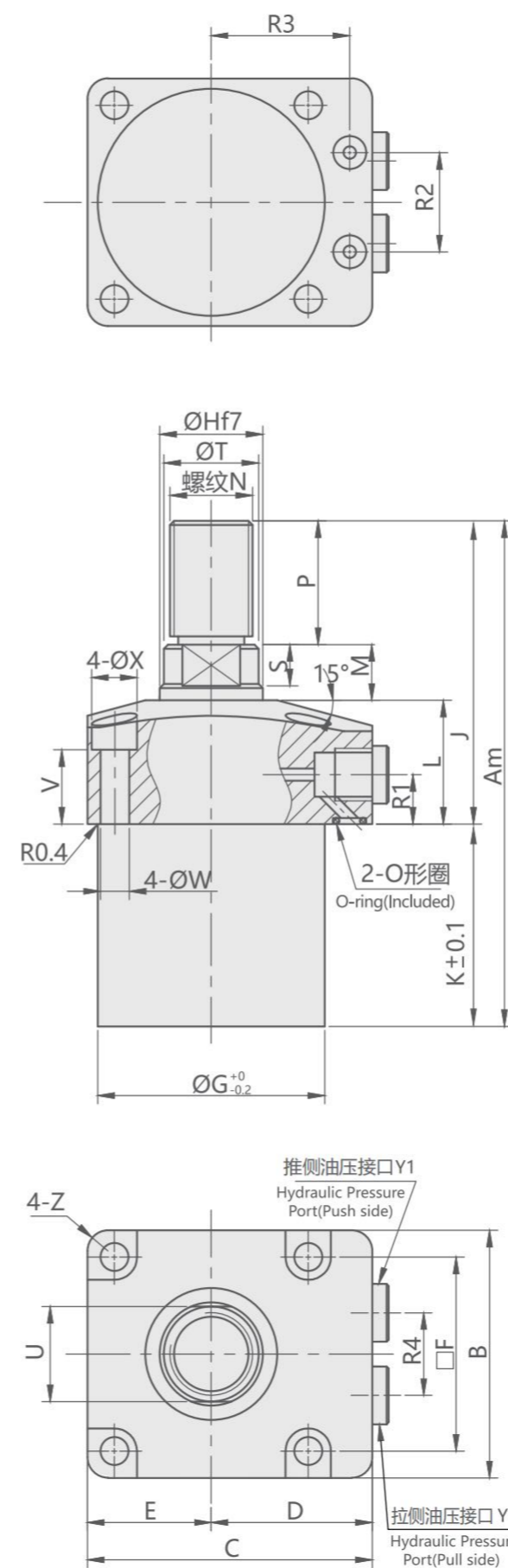

型号 Model	CCNA02 -□M	CCNA04 -□M	CCNA06 -□M	CCNA10 -□M	CCNA16 -□M	CCNA25 -□M
B	45	50	57	70	86	108
C	55	60	66	82	96	120
D	32.5	35	37.5	47	53	66
E	22.5	25	28.5	35	43	54
F	35	40	46	56	68	88
ΦG	39	47	53	63	78	100
ΦH	16 <sup>-0.016/-0.034</sup>	18 <sup>-0.016/-0.034</sup>	22.4 <sup>-0.020/-0.041</sup>	25 <sup>-0.020/-0.041</sup>	30 <sup>-0.020/-0.041</sup>	35.5 <sup>-0.025/-0.050</sup>
J	58	64.5	70	81	92	110.5
L	27.5	28	30	37.5	41.5	48.5
M	10.5	11.5	12.5	13.5	15.5	17
N	M12x1.25	M14x1.5	M16x1.5	M20x1.5	M24x1.5	M30x1.5
P	20	25	27.5	30	35	45
R1	12.5	12.5	12.5	14	14	21
R2	22	24	28	36	45	50
R3	25	28	30.5	36	42	57
R4	20	22	26	30	38	50
S	7	8	9	10	12	14
ΦT	14±0.2	16±0.2	20±0.2	23±0.2	28±0.2	33.5±0.2
U	12	14	17	19	24	30
V	18	17	17	20	20	20
ΦW	5.5	5.5	6.8	9	11	14
ΦX	9.5	9.5	11	14	17.5	20
Y1	G1/8	G1/8	G1/8	G1/4	G1/4	G3/8
Z	R3	R5	R5	R6	R7	R10
O形圈	P7	P7	P7	P8	P8	P10
Am 行程	10	86	95.5	101.5	118.5	-
	15	86	95.5	101.5	-	-
	20	101	110.5	116.5	118.5	131
	30	101	110.5	116.5	138.5	151
	40	121	130.5	136.5	138.5	151
	50	121	130.5	136.5	158.5	171
	60	141	150.5	156.5	158.5	171
	70	141	150.5	156.5	178.5	191
	80	-	-	176.5	178.5	191
	90	-	-	176.5	198.5	211
100	-	-	-	198.5	211	
110	-	-	-	-	240.5	
K 行程	10	28	31	31.5	37.5	39
	15	28	31	31.5	-	-
	20	43	46	46.5	37.5	39
	30	43	46	46.5	57.5	59
	40	63	66	66.5	57.5	59
	50	63	66	66.5	77.5	79
	60	83	86	86.5	77.5	79
	70	83	86	86.5	97.5	99
	80	-	-	106.5	97.5	99
	90	-	-	106.5	117.5	119
100	-	-	-	117.5	119	
110	-	-	-	-	130	

注:可选装CVCF调速阀

# DBA&DBC

紧凑型直线油压缸

## DBA&DBC HYDRAULIC BLOCK CYLINDER



### 产品特性

此系列产品结构紧凑，安装方便

最大操作压力：350 kgf/cm<sup>2</sup>  
最小操作压力：10 kgf/cm<sup>2</sup>

### FEATURES

This series of products have compact structure and convenient installation.

Max.operating pressure: 350 kgf/cm<sup>2</sup>  
Min.operating pressure: 10 kgf/cm<sup>2</sup>

### 注意事项

使用CZL(速度控制阀)时请使用7MPa以下

### NOTE

If used with CZL, the operating pressure should be below 7MPa.

### 订购标示法 ORDERING INDICATION

示例: DBA-032CS

<b>DBA</b>	系列 Series	DBA&DBC	
<b>032</b>	油缸内径 Hydraulic cylinder inside diameter	032 (025/032/040/050)	
<b>C</b>	配管方式 Piping Method	B: 外配管型(G螺纹) C: 板式连接型(附带G螺纹堵头)	B: Pipe type (G thread) C: Gasket type (with G thread plug)
<b>S</b>	行程代码 Stroke	S:全行程25 M:全行程50	S: Total stroke 25mm M: Total stroke 50mm

### 规格参数表 SPECIFICATIONS

型号	总行程	推出容积	拉入容积	推出受压面积	拉入受压面积	使用温度范围	使用流体
MODEL	CLAMPING STROKE(mm)	CYLINDER CAPACITY CLAMP(cm <sup>3</sup> )	CYLINDER CAPACITY UNCLAMP(cm <sup>3</sup> )	EFF.PISTON AREA CLAMP(cm <sup>2</sup> )	EFF.PISTON AREA UNCLAMP(cm <sup>2</sup> )	RANGE OF TEMPERATURE(°C)	USABLE FLUID
DBA/DBC-025	S:25/M:50	12.3/24.5	7.3/14.5	4.9	2.9	0~+70°C	相当于ISO黏度等级的ISO-VG-32一般液压油 Recommended: ISO-VG-32 hydraulic oil equivalent to ISO viscosity grade
DBA/DBC-032	S:25/M:50	20.1/40.2	12.3/24.5	8.0	4.9	0~+70°C	
DBA/DBC-040	S:25/M:50	31.4/62.8	19.1/38.3	12.6	7.7	0~+70°C	
DBA/DBC-050	S:25/M:50	49.1/98.2	29/58	19.6	11.6	0~+70°C	

### DBA-B 配管型

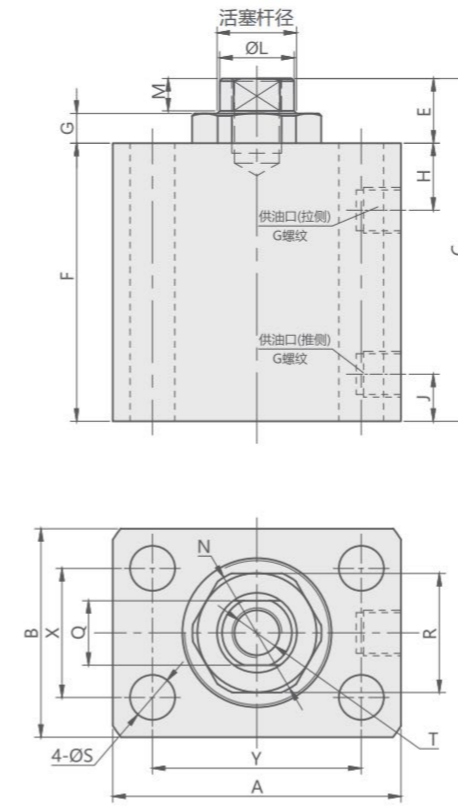

### DBA-C 板式连接型

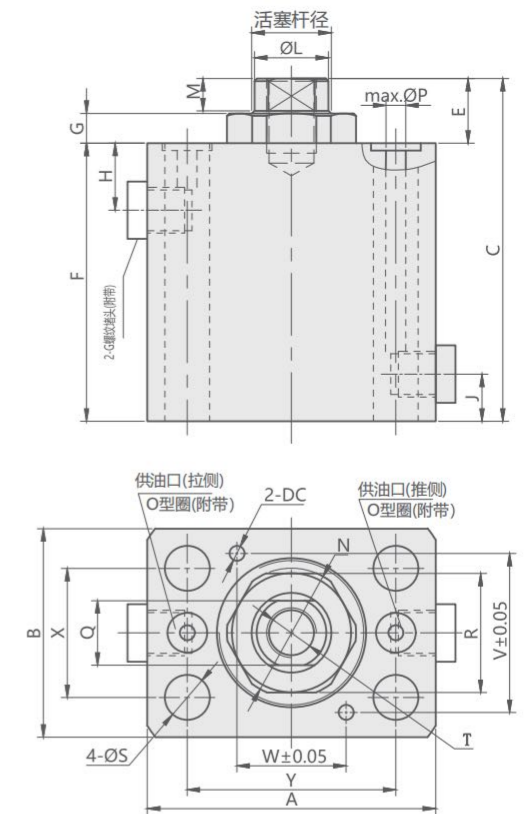

### 外形尺寸表

Unit:mm

型号 Model	DBA-025		DBA-032		DBA-040		DBA-050	
	S	M	S	M	S	M	S	M
<b>A</b>	58		70		80		100	
<b>B</b>	42		50		55		65	
<b>C</b>	69	94	78	103	86	111	92	117
<b>E</b>	13		15		17		18	
<b>F</b>	56	81	63	88	69	94	74	99
<b>G</b>	6		6.5		7		7	
<b>H</b>	11.5		15		17		18	
<b>J</b>	9.5		10		12		13	
<b>L</b>	15.5		19.5		24.3		31.3	
<b>M</b>	6.5		8		9.3		10.3	
<b>N</b>	26.5		33		40		50	
<b>P</b>	3		5		5		5	
<b>Q</b>	13		17		21		27	
<b>R</b>	24		30		36		46	
<b>S</b>	9		11		11		13.5	
<b>T</b>	M10螺纹深15		M12螺纹深18		M16螺纹深23		M20螺纹深28	
<b>V</b>	32		38		44		52	
<b>W</b>	22		26		32		44	
<b>X</b>	26		30		35		42	
<b>Y</b>	42		50		60		76	
<b>DC*1</b>	Φ3深5		Φ5深5		Φ5深5		Φ5深5	
<b>供油口</b>	<b>B型</b>		<b>B型</b>		<b>B型</b>		<b>B型</b>	
<b>G螺纹堵头</b>	<b>C型</b>		<b>C型</b>		<b>C型</b>		<b>C型</b>	
<b>O形密封圈</b>	<b>C型</b>		<b>C型</b>		<b>C型</b>		<b>C型</b>	
<b>活塞杆径</b>	Φ16		Φ20		Φ25		Φ32	

注意事项:\*1: 能使用DC孔和弹簧销对油缸进行定位

DBC-B 配管型

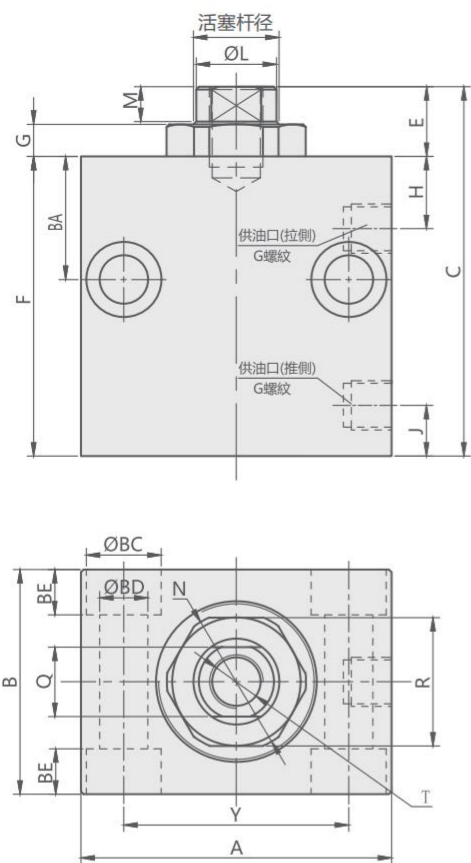

DBC-C 板式连接型

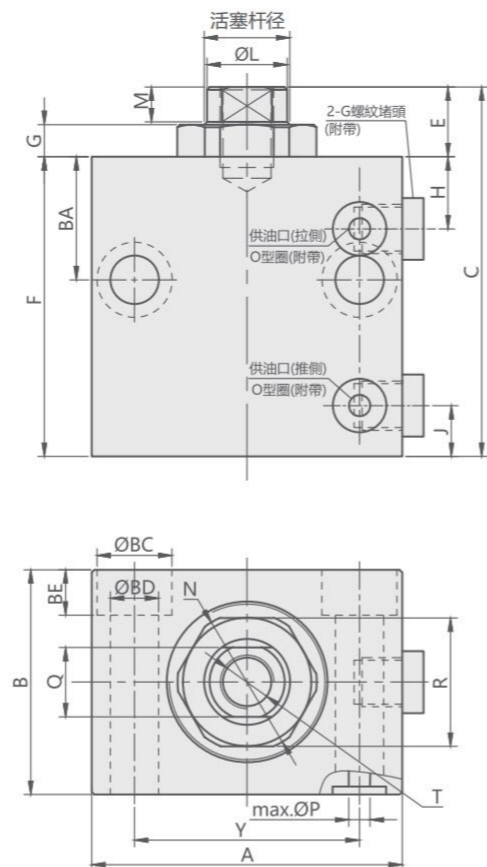

外形尺寸表

Unit:mm

型号 Model	DBC-025		DBC-032		DBC-040		DBC-050	
行动代码	S	M	S	M	S	M	S	M
A	58		70		80		100	
B	42		50		55		65	
C	69	94	78	103	86	111	92	117
E	13		15		17		18	
F	56	81	63	88	69	94	74	99
G	6		6.5		7		7	
H	11.5		15		17		18	
J	9.5		10		12		13	
L	15.5		19.5		24.3		31.3	
M	6.5		8		9.3		10.3	
N	26.5		33		40		50	
P	3		5		5		5	
Q	13		17		21		27	
R	24		30		36		46	
T	M10螺纹深15		M12螺纹深18		M16螺纹深23		M20螺纹深28	
Y	42		50		60		76	
BA	23		27		32		34	
BC	14		17.5		17.5		20	
BD	9		11		11		13.5	
BE	8.5		10.5		10.5		12.5	
供油口	B型	G1/8	G1/8	G1/8	G1/4	G1/4	G1/4	G1/4
G螺纹堵头	C型	G1/8	G1/8	G1/8	G1/4	G1/4	G1/4	G1/4
O形密封圈	C型	P5	P7	P7	P7	P7	P7	P7
活塞杆径		Φ16	Φ20	Φ20	Φ25	Φ25	Φ32	Φ32

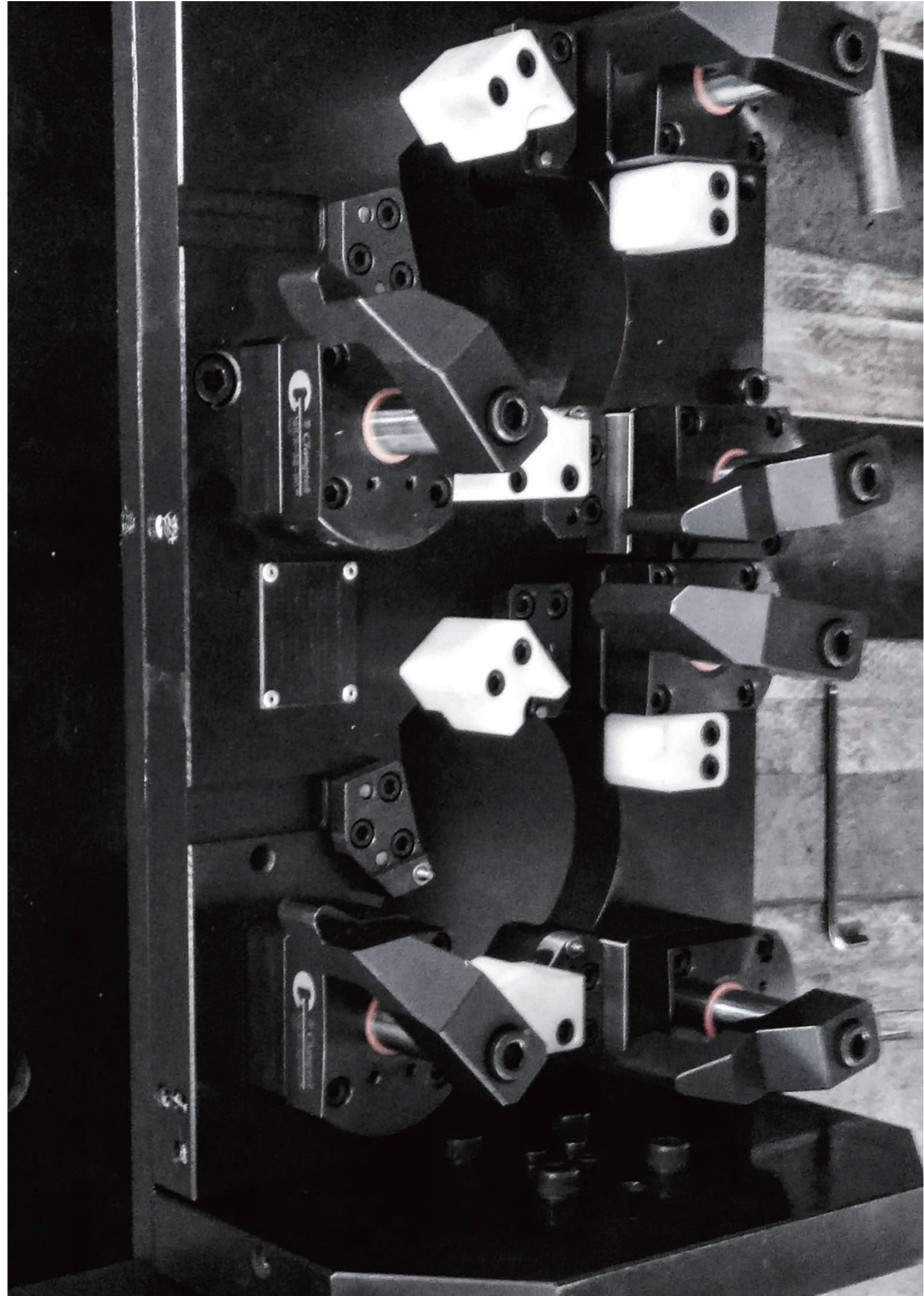

# CHTB

## 薄型油压缸

### CHTB HYDRAULIC PUSH PULL CYLINDER



#### 产品特性

体积小, 节省空间, 安装空间受限制时的选择。标准化规格, 直接安装, 不需其它配件, 降低成本。  
缸体材质采用机械构造用碳素钢, 内壁特殊加工处理, 表面光滑, 使用寿命长。轴向, 侧向油路板型免配管, 提升整体美观。

最大操作压力: 140 kgf/cm<sup>2</sup>  
最小操作压力: 5 kgf/cm<sup>2</sup>  
作动方式: 复动式

#### FEATURES

The CHTB series' compact construction helps conserve work space and can be utilized in restricted areas. With the standardized structure, the cylinder can be installed directly and does not require any accessories to operate. The CHTB hydraulic cylinders are manufactured with industrial grade carbon steel. The smooth interior is processed specifically to enhance product performance and increase product lifespan.

Max. operating pressure: 140 kgf/cm<sup>2</sup>  
Min. operating pressure: 5 kgf/cm<sup>2</sup>  
Double acting

#### 剖面图 Sectional view

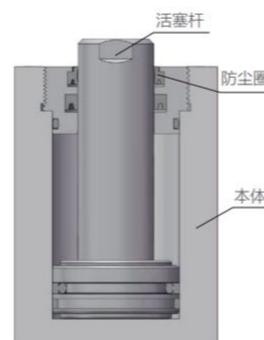

#### 注意事项

可接受订制, 欢迎与本公司洽询。CHTB-LAM和CHTB-LWM系列, 行程10mm无附键槽及平键。

#### NOTE

Customization is available upon request, please contact us for more info.  
CHTB-LAM and CHTB-LWM series, stroke 10mm without keyway and parallel key.

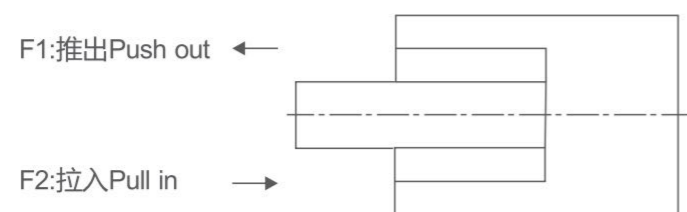

#### 订购标示法 ORDERING INDICATION

示例: CHTB-SD32-20N

CHTB	系列 Series	CHTB	
SD	安装型式 Mounting type	SD:	轴向单轴安装型 Axial single end rod type
		SW:	轴向双轴安装型 Axial double end rod type
		SDMA:	轴向前油路板型 Axial front manifold type
		SDMB:	轴向后油路板型 Axial back manifold type
		LA:	侧向单轴安装型 Lateral single end rod type
		LW:	侧向双轴安装型 Lateral double end rod type
		LAM:	侧向油路板单轴安装型 Lateral manifold single end rod type
LWM:	侧向油路板双轴安装型 Lateral manifold double end rod type		
32	油缸内径 Hydraulic cylinder inside diameter	Φ20, Φ25, Φ32, Φ40, Φ50, Φ63, Φ80	
20	标准行程 Standard stroke	5mm, 10mm, 15mm, 20mm, 25mm, 30mm, 35mm, 40mm, 50mm 其它行程请来电咨询 For other stroke, please inquire.	
N	轴端形式 Rod end type	N:	内牙 Female thread
		W:	外牙 Male thread

#### 注意:

CHTB系列产品因其薄型结构, 使用时请务必避免承受侧向负荷, 如有需要承受侧向负荷或其行程超出标准, 订购前请与我司联系。

#### 规格参数表 SPECIFICATIONS

油缸内径 HYDRAULIC CYLINDER INSIDE DIAMETER(mm)	活塞杆径 PISTON DIAMETER(mm)	受压面积 PRESSURE AREA(cm <sup>2</sup> )		操作压力 OPERATION PRESSURE(kgf/cm <sup>2</sup> )										使用温度范围 RANGE OF TEMPERATURE(°C)
		F1	F2	10		35		70		100		140		
		F1	F2	F1	F2	F1	F2	F1	F2	F1	F2	F1	F2	-10~+60°C
Φ20	Φ12	3.14	2.01	31	20	110	71	220	141	314	201	440	281	-10~+60°C
Φ25	Φ14	4.91	3.37	49	34	172	118	344	236	491	337	687	472	-10~+60°C
Φ32	Φ20	8.04	4.9	80	49	281	172	563	343	804	490	1126	686	-10~+60°C
Φ40	Φ25	12.57	7.66	126	77	440	268	880	536	1257	766	1760	1072	-10~+60°C
Φ50	Φ30	19.64	12.57	196	126	687	440	1375	880	1964	1257	2750	1760	-10~+60°C
Φ63	Φ35	31.17	21.55	312	216	1091	754	2182	1509	3117	2155	4364	3017	-10~+60°C
Φ80	CHTB Φ45	50.27	34.37	503	344	1759	1203	3519	2406	5027	3437	7038	4812	-10~+60°C
	CHTM Φ40	50.27	37.7	503	377	1759	1320	3519	2639	5027	3770	7038	5278	-10~+60°C
Φ100	Φ56	78.53	53.9	785	539	2748	1886.5	5497	3773	7853	5390	10974	7546	-10~+60°C

使用流体: 相当于ISO黏度等级的ISO-VG-32一般液压油  
Recommended: ISO-VG-32 hydraulic oil equivalent to ISO viscosity grade

SD-N轴向单轴安装之轴端内牙型

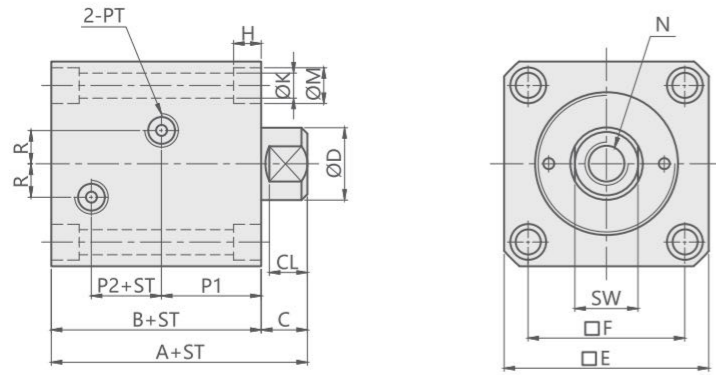

SD-W轴向单轴安装之轴端外牙型

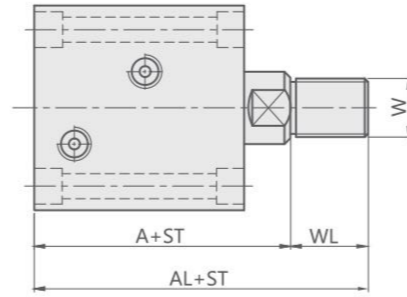

SW-N轴向双轴安装之轴端内牙型

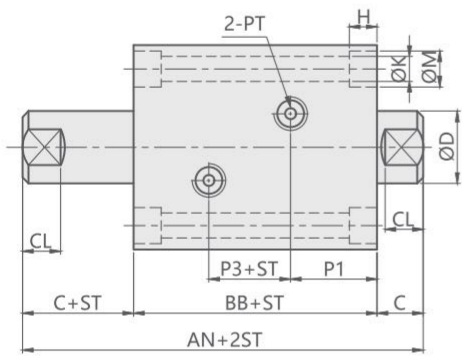

SW-W轴向双轴安装之轴端外牙型

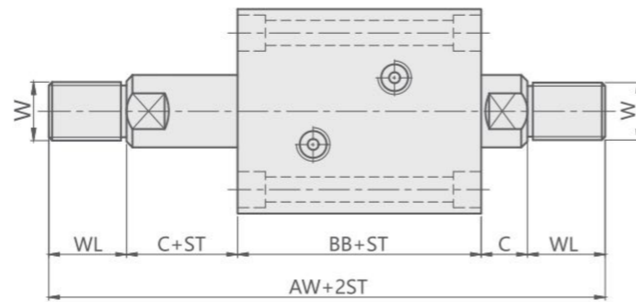

ST=Stroke

CHTB Hydraulic axial mounting type SD & SW

Unit:mm

Bore	Φ20	Φ25	Φ32	Φ40	Φ50	Φ63	Φ80	Φ100
A	51	53	64	65	71	80	95	105
AL	71	75	89	95	106	120	140	165
AN	-	-	89	90	97	108	127	140
AW	-	-	139	150	167	188	217	260
B	43	45	54	55	60	67	78	88
BB	-	-	69	70	75	82	93	106
C	8	8	10	10	11	13	17	17
CL	6	6	7	7	8	10	14	13
D	12	14	20	25	30	35	45	56
SW	10	12	17	22	27	32	41	50
E	42	48	62	70	80	94	114	134
F	30	36	47	52	58	69	86	102
H	5.5	5.5	6.5	9	11	13	15	17.5
K	5.6	5.6	6.8	9	11	13	15	18
M	9	9	11	14	18	20	22	26
N	M8x1.25x12D	M10x1.5x15D	M12x1.75x15D	M16x2.0x20D	M20x2.5x25D	M27x3.0x35D	M30x3.5x35D	M36x4.0x40D
W	M10x1.25	M12x1.25	M16x1.5	M22x1.5	M26x1.5	M30x1.5	M39x1.5	M48x1.5
WL	20	22	25	30	35	40	45	60
P1	22.5	23	28	28	29.5	31	33	39
P2	11	12	14	15	18	20	27	28
P3	-	-	13	14	16	20	27	28
R	5	5	10	10	10	10	15	15
PT	1/8	1/8	1/4	1/4	1/4	3/8	3/8	3/8

CHTB Hydraulic axial mounting type SDMA & SDMB Unit:mm

Bore	Φ20	Φ25	Φ32	Φ40	Φ50	Φ63	Φ80
A	51	53	64	65	71	80	95
AL	71	75	89	95	106	120	140
B	43	45	54	55	60	67	78
C	8	8	10	10	11	13	17
CL	6	6	7	7	8	10	14
D	12	14	20	25	30	35	45
SW	10	12	17	22	27	32	41
E	42	48	62	70	80	94	114
F	30	36	47	52	58	69	86
H	5.5	5.5	6.5	9	11	13	15
K	5.6	5.6	6.8	9	11	13	15
M	9	9	11	14	18	20	22
N	M8x1.25x12D	M10x1.5x15D	M12x1.75x15D	M16x2.0x20D	M20x2.5x25D	M27x3.0x35D	M30x3.5x35D
W	M10x1.25	M12x1.25	M16x1.5	M22x1.5	M26x1.5	M30x1.5	M39x1.5
WL	20	22	25	30	35	40	45
P1	16.5	19.5	24	27	32	38	47
SDMA R1	13	18	24	26	27	35	45
O1	S4	P4	P6	P6	P6	P8	P11
P2	13	16	20	24	29	35	44
SDMB R2	11	13	20	20	20	26	30
O2	P5	P7	P9	P9	P9	P11	P11

SDMA-N轴向前油路板的轴端内牙型

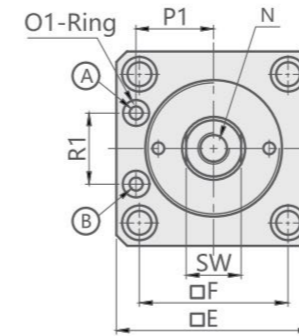

SDMB-N轴向后油路板的轴端内牙型

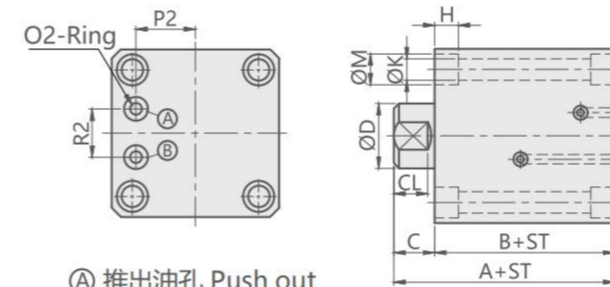

- Ⓐ 推出油孔 Push out
- Ⓑ 拉入油孔 Pull in

SDMA-W轴向前油路板的轴端外牙型

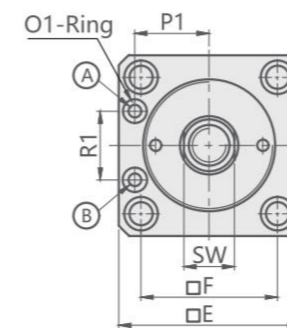

SDMB-W轴向后油路板的轴端外牙型

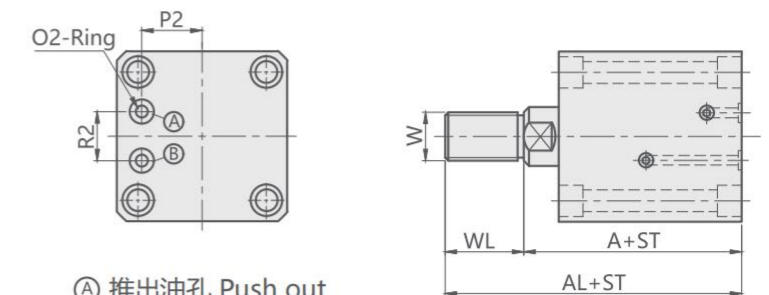

- Ⓐ 推出油孔 Push out
- Ⓑ 拉入油孔 Pull in

LA-N侧向单轴安装之轴端内牙型

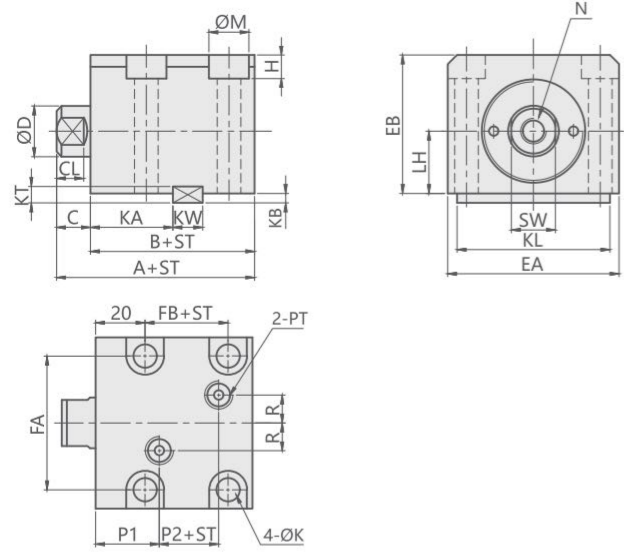

LW-N侧向双轴安装之轴端内牙型

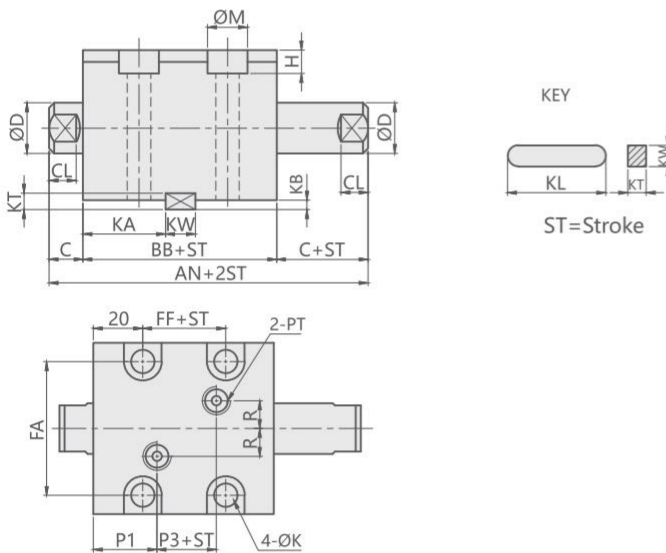

LA-W侧向单轴安装之轴端外牙型

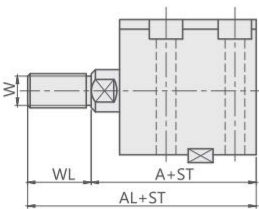

LW-W侧向双轴安装之轴端外牙型

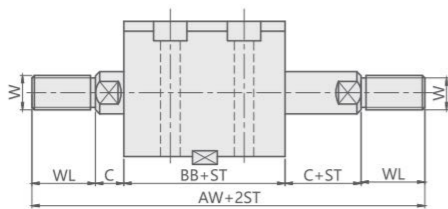

CHTB Hydraulic side mounting type LA & LW

Unit:mm

Bore	Φ32	Φ40	Φ50	Φ63	Φ80	Φ100
A	64	65	71	80	98	105
AL	89	95	106	120	143	165
AN	89	90	97	108	129	140
AW	139	150	167	188	219	260
B	54	55	60	67	81	88
BB	69	70	75	82	95	106
C	10	10	11	13	17	17
CL	7	7	8	10	14	13
D	20	25	30	35	45	56
SW	17	22	27	32	41	50
EA	70	80	94	114	134	160
EB	56	64	74	89	109	129
LH	25	29	34	42	52	62
FA	56	62	74	90	110	134
FB	24	23	27	32	41	44
FF	32	32	35	42	41	44
H	9	11	13	15	15	17
K	9	11	13	15	15	18
M	14	18	20	22	22	26
N	M12x1.75 x15D	M16x2.0 x20D	M20x2.5 x25D	M27x3.0 x35D	M30x3.5 x35D	M36x4 x40D
W	M16x1.5	M22x1.5	M26x1.5	M30x1.5	M39x1.5	M48x1.5
WL	25	30	35	40	45	60
P1	28	28	29.5	31	35	39
P2	14	15	18	20	28	28
P3	13	14	16	20	25	28
R	10	10	10	10	15	15
PT	1/4	1/4	1/4	3/8	3/8	3/8
KW	12	12	14	16	16	16
KT	8	8	9	10	10	10
KL	63	70	80	100	100	100
KA	28	28	29	31	34	34
KB	4.5	4.5	5	5.5	5.5	5.5

注:行程<20的无键槽及平键

LAM-N侧向油路板单轴安装之轴端内牙型

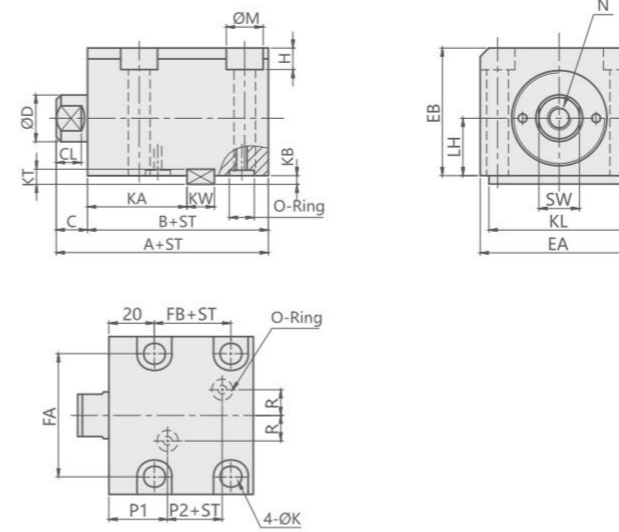

LWM-N侧向油路板双轴安装之轴端内牙型

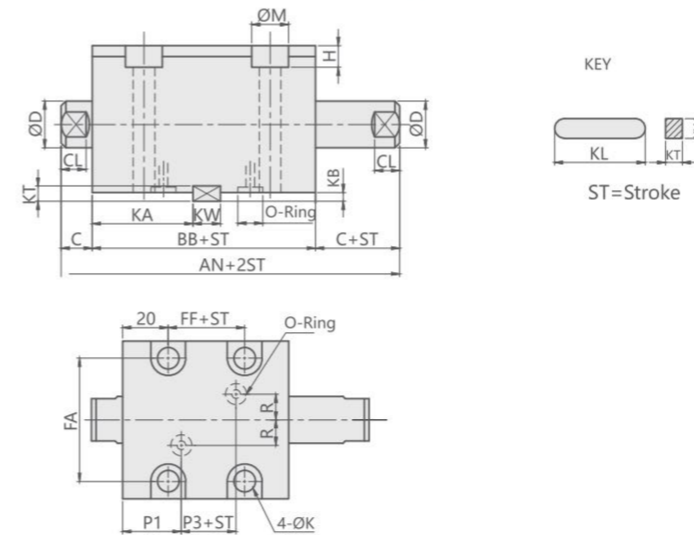

LAM-W侧向油路板单轴安装之轴端外牙型

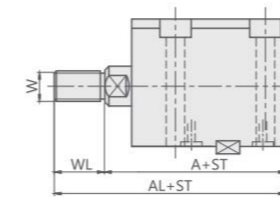

LWM-W侧向油路板双轴安装之轴端外牙型

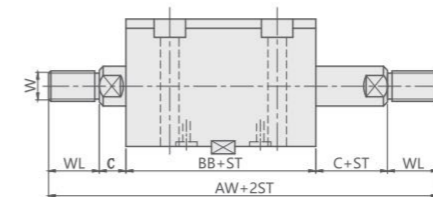

CHTB Hydraulic manifold type LAM & LWM

Unit:mm

Bore	Φ32	Φ40	Φ50	Φ63	Φ80
A	64	65	71	80	98
AL	89	95	106	120	143
AN	89	90	97	108	-
AW	139	150	167	188	-
B	54	55	60	67	81
BB	69	70	75	82	-
C	10	10	11	13	17
CL	7	7	8	10	14
D	20	25	30	35	45
SW	17	22	27	32	41
EA	70	80	94	114	134
EB	56	64	74	89	109
LH	25	29	34	42	52
FA	56	62	74	90	110
FB	24	23	27	32	41
FF	32	32	35	42	-
H	9	11	13	15	15
K	9	11	13	15	15
M	14	18	20	22	22
N	M12x1.75 x15D	M16x2.0 x20D	M20x2.5 x25D	M27x3.0 x35D	M30x3.5 x35D
W	M16x1.5	M22x1.5	M26x1.5	M30x1.5	M39x1.5
WL	25	30	35	40	45
P1	28	28	29.5	31	35
P2	14	15	18	20	28
P3	13	14	16	20	-
R	10	10	10	10	15
O	P9	P9	P11	P11	P11
KW	12	12	14	16	16
KT	8	8	9	10	10
KL	63	70	80	100	100
KB	4.5	4.5	5	5.5	5.5
KA	38	38	40	42	52

订购标示法 ORDERING INDICATION

示例: CHTM-SD32-20N-S1 D/A

	<b>CHTM</b>	系列 Series	CHTM
	<b>SD</b>	安装方式 Mounting type	SD: 轴向单轴安装型 Single end rod type SW: 轴向双轴安装型 Double end rod type
	<b>32</b>	油缸内径 Hydraulic cylinder inside diameter	Φ32, Φ40, Φ50, Φ63, Φ80
	<b>20</b>	标准行程 Standard stroke	10, 20, 30, 40, 50
	<b>N</b>	轴端形式 Rod end type	N: 内牙 Female thread N W: 外牙 Male thread W
<b>S1 D/A</b>	近接开关 Sensor switch	一个S1, 2个S2 电压AC4-120V 电流5-40mA	1Pcs of S1, 2Pcs of S2 Pressure AC 4-120V Electricity 5-40mA

注: 标配近接形状为二线式

Note: The standard connection switch is two-wire type.

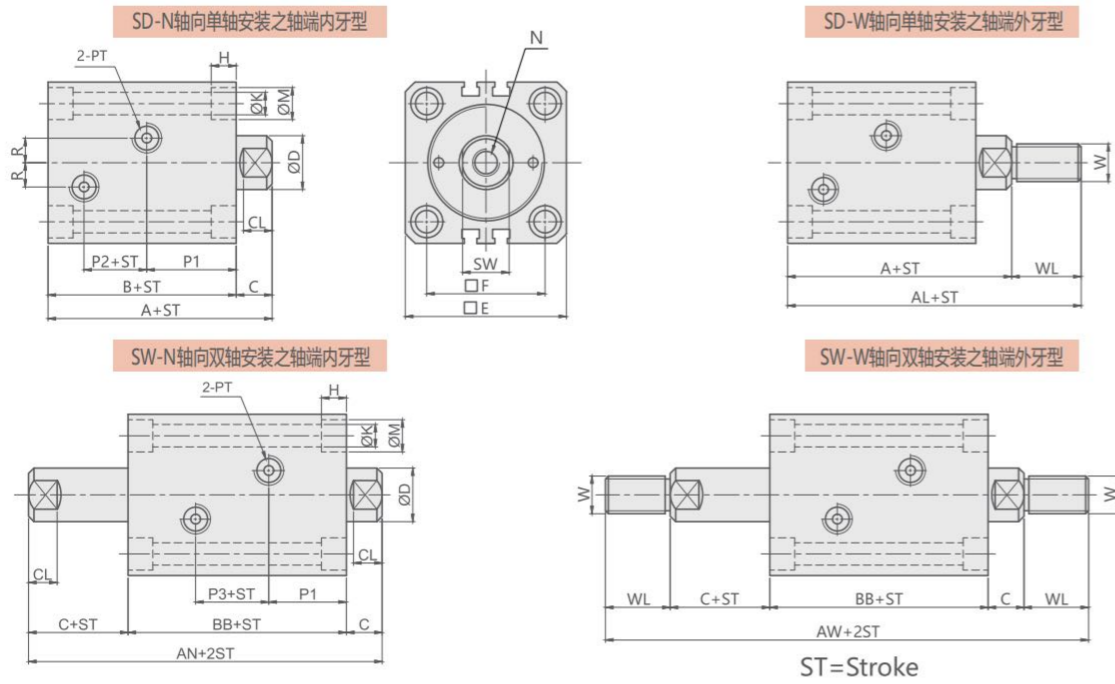

CHTM Hydraulic axial mounting type SD & SW

Unit:mm

Bore	Φ32	Φ40	Φ50	Φ63	Φ80	Φ100
A	83	80	86	97	112	117
AL	108	110	121	142	167	187
AN	104	101	109	120	140	148
AW	154	161	179	210	250	288
B	73	70	75	84	95	100
BB	84	81	87	94	106	114
C	10	10	11	13	17	17
CL	7	7	8	10	14	13
D	20	25	30	35	40	56
SW	17	21	27	32	37	50
E	62	70	80	94	114	134
F	47	52	58	69	86	102
H	6.5	9	11	13	15	17.5
K	6.8	9	11	13	15	18
M	11	14	18	20	22	26
N	M12x1.75x15D	M16x2.0x20D	M20x2.5x25D	M27x3.0x33D	M30x3.5x33D	M36x4x40D
W	M16x1.5	M20x1.5	M24x1.5	M30x1.5	M36x1.5	M48x1.5
WL	25	30	35	45	55	70
P1	27	27	28	30	35	39
P2	29	27	31	36	38	36
P3	30	27	31	34	36	36
R	10	10	10	10	15	15
PT	1/4	1/4	1/4	1/4	3/8	3/8

注: 使用压力≥10MPa时, 缸体需要采用不锈钢材质。

外形尺寸图 External Dimensions

• CHTM-LA单轴径向型  
内径: Φ63, Φ80, Φ100 双条感应开关沟槽如下图

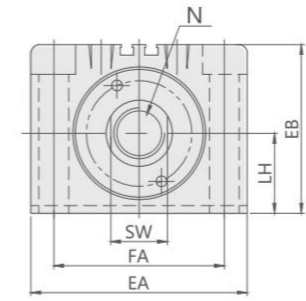

ST=Stroke(行程)

内径: Φ32, Φ40, Φ50 单条感应开关沟槽如下图

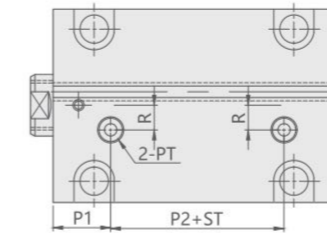

• CHTM-LA双轴径向型

内径: Φ63, Φ80, Φ100 双条感应开关沟槽如图

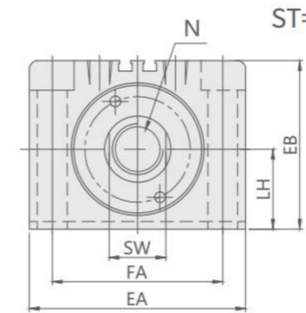

ST=Stroke(行程)

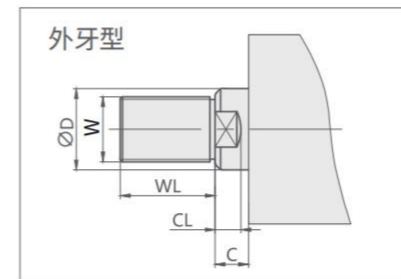

外牙型

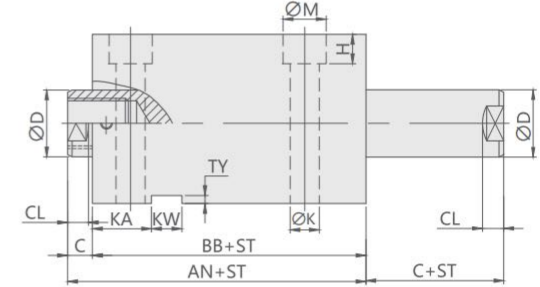
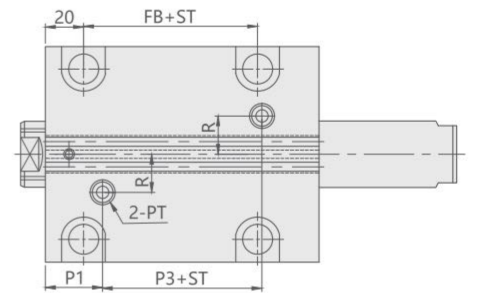
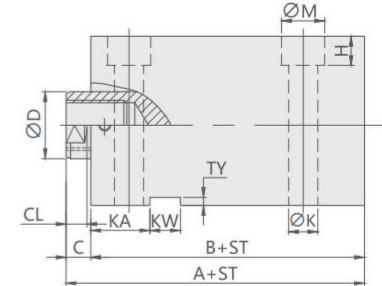
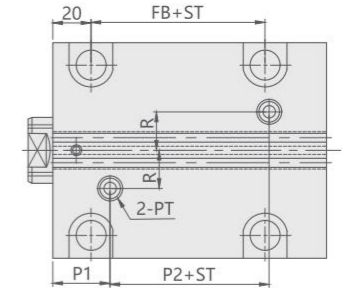

内径: Φ40, Φ50 单条感应开关沟槽如下图

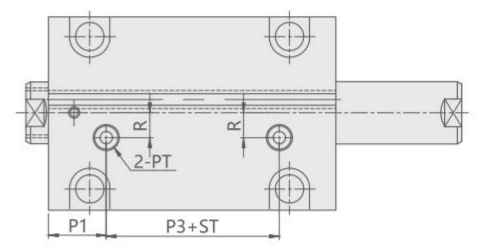

Unit:mm

Bore	A	AN	B	BB	C	CL	D	EA	EB	FA	FB	H	K	KA	KW	LH	M	内牙 N	外牙 W WL	P1	P2	P3	PT	SW	R	TY	
32	83	-	73	-	10	7	20	70	56	56	24	9	9	28	12	25	14	M12*1.75-15D	M16*1.5	25	27	29	-	1/4	17	10	4
40	80	91	70	81	10	7	25	80	64	62	23	11	11	28	12	29	18	M16*2.0-20D	M20*1.5	30	27	27	27	1/4	21	10	4
50	86	98	75	87	11	8	30	94	74	74	27	13	14	29	14	34	20	M20*2.5-25D	M24*1.5	35	28	31	31	1/4	27	10	4
63	97	107	84	94	13	10	35	114	89	90	32	15	16	31	16	42	23	M27*3.0-33D	M30*1.5	45	30	36	34	1/4	32	20	4
80	112	123	95	106	17	14	40	134	109	110	41	15	16	34	16	52	23	M30*3.5-33D	M36*1.5	55	35	38	36	3/8	37	25	4
100	117	131	100	116	17	13	56	160	129	134	44	17	18	34	16	62	26	M36*4.0-40D	M48*1.5	70	39	36	36	3/8	50	25	5

注: 1. 当行程 < 10mm (不含) 以内, 不加工键槽 (即取消尺寸 KA, KW, TY)  
2. 超出以上行程请另联系我司业务部。

## 外形尺寸图 External Dimensions

- CHTM-LAM油路板式径向型  
内牙型

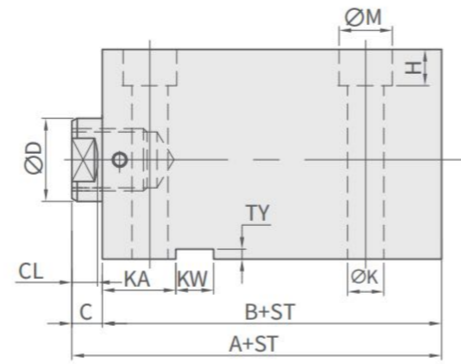
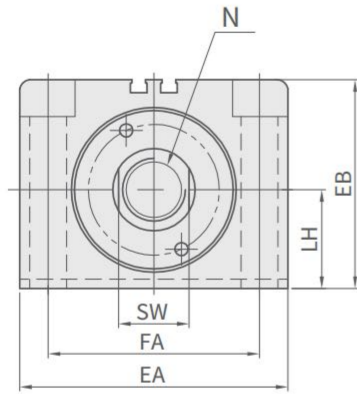
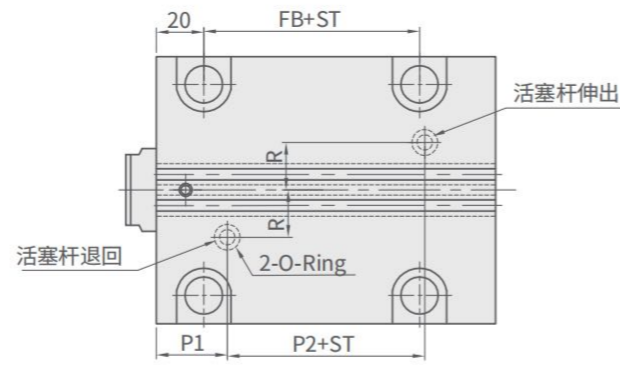

ST=Stroke(行程)

外牙型

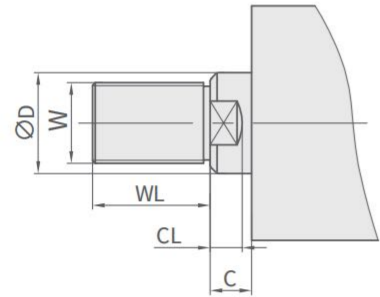

内径: Ø32, Ø40, Ø50单条感应开关沟槽如下图

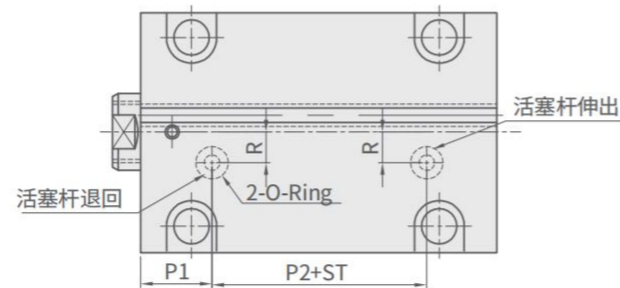

Unit:mm

Bore	A	B	C	CL	D	EA	EB	FA	FB	H	K	KA	KW	LH	M	内牙 N	外牙 W WL	O	P1	P2	R	SW	TY
32	83	73	10	7	20	70	56	56	34	9	9	41	12	25	14	M12*1.7-15D	M16*1.5 25	P9	27	29	10	17	4
40	80	70	10	7	25	80	64	62	23	11	11	42	12	29	18	M16*2.0-20D	M20*1.5 30	P9	27	27	10	21	4
50	86	75	11	8	30	94	74	74	27	13	14	44	14	34	20	M20*2.5-25D	M24*1.5 35	P11	28	31	10	27	4
63	97	84	13	10	35	114	89	90	32	15	16	47	16	42	23	M27*3.0-33D	M30*1.5 45	P11	30	36	20	32	4
80	112	95	17	14	40	134	109	110	41	15	16	54	16	52	23	M30*3.5-33D	M36*1.5 55	P11	35	38	25	37	4
100	117	100	17	13	56	160	129	134	44	17	18	56.5	16	62	26	M36*4.0-40D	M48*1.5 70	P11	39	36	25	50	5

注: 1.当行程 < 10mm(不含)以内, 不加工键槽(即取消尺寸KA,KW,TY)  
2.超出以上行程请另联系我司业务部。

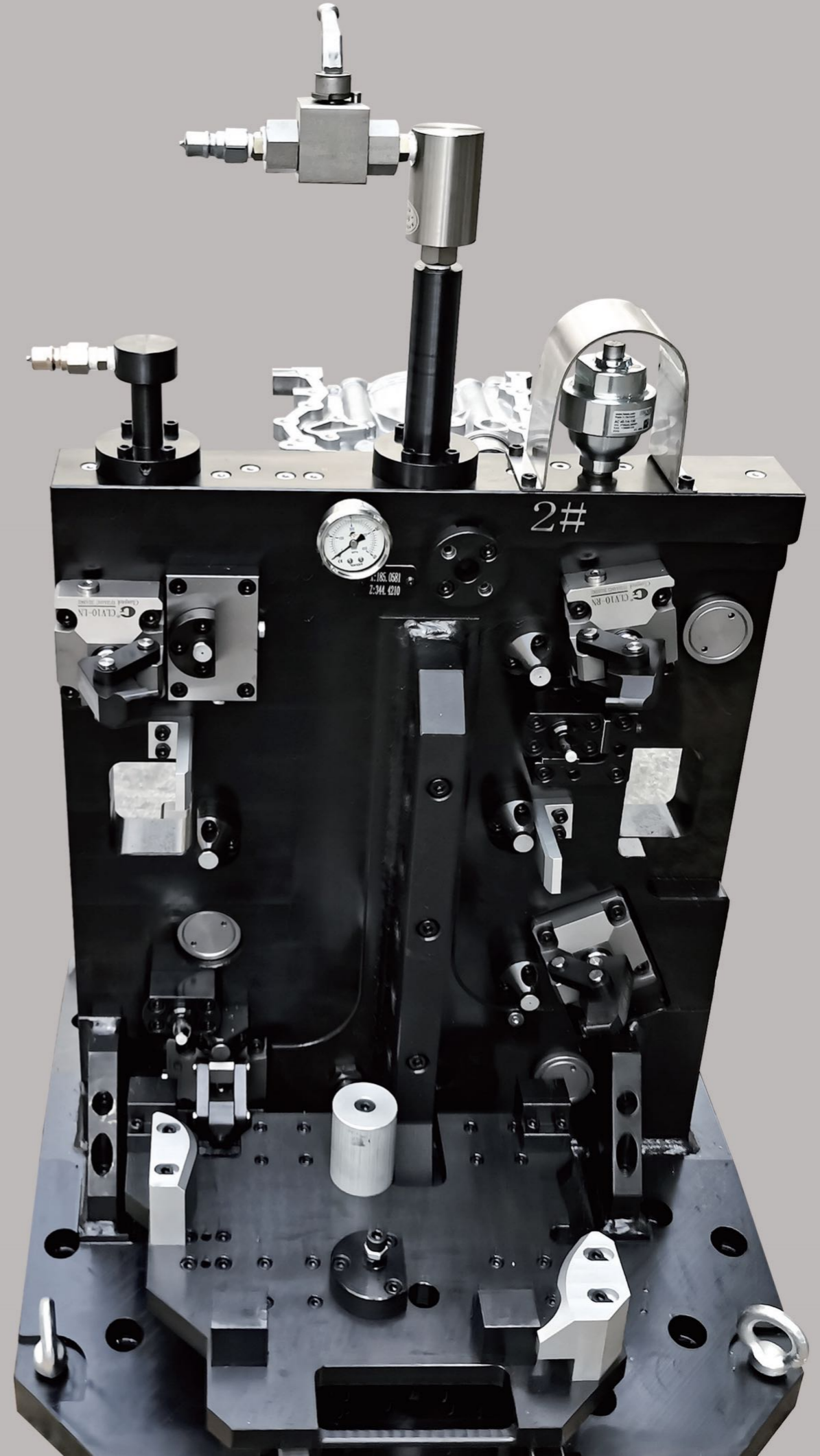

# HBC

## 块型油压缸

## HBC HYDRAULIC BLOCK CYLINDER

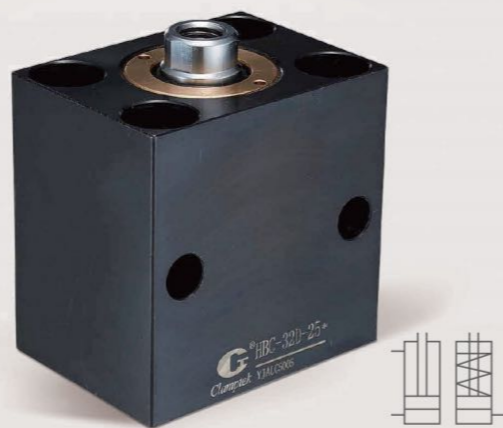

### 产品特性

本系列油压缸为德规尺寸,采用进口油封保证耐压标准化规格,具互换性。安装型式为轴向,侧向两用型,作动方式分为单动常入型与复动式。

最大操作压力: 300 kgf/cm<sup>2</sup>  
 最小操作压力: 100 kgf/cm<sup>2</sup>  
 作动方式: 单动式和复动式

### FEATURES

The HBC series is optimally designed with imported oil seals from Germany to help improve pressure resistance. With its standardized structure, this cylinder is interchangeable with other standard hydraulic push-pull cylinders from other brands. The installations are dual with axial and lateral types. Acting Type Options: Single-Acting or Double Acting Type

Max.operating pressure: 300 kgf/cm<sup>2</sup>  
 Min. operating pressure: 100 kgf/cm<sup>2</sup>  
 Single acting and Double acting

剖面图 Sectional view (复动型)

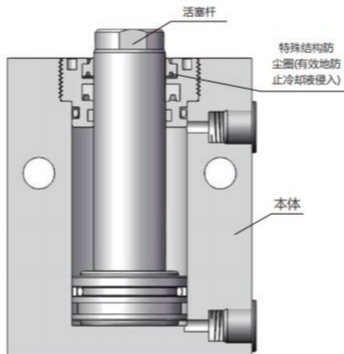

### 注意事项

可接受订制(300<P<500), 欢迎与本公司洽询

### NOTE

Customization is available upon request (300 < P < 500), please contact us for more info.

### 订购标示法 ORDERING INDICATION

#### 示例: HBC-32S-20

HBC	系列 Series	HBC
32	油缸内径 Hydraulic cylinder inside diameter	Φ16,Φ25,Φ32,Φ40
S	作动方式 Acting type	S单动Single-acting D复动Double-acting
20	标准行程 Standard stroke	请参考尺寸表 Refer to the dimension table

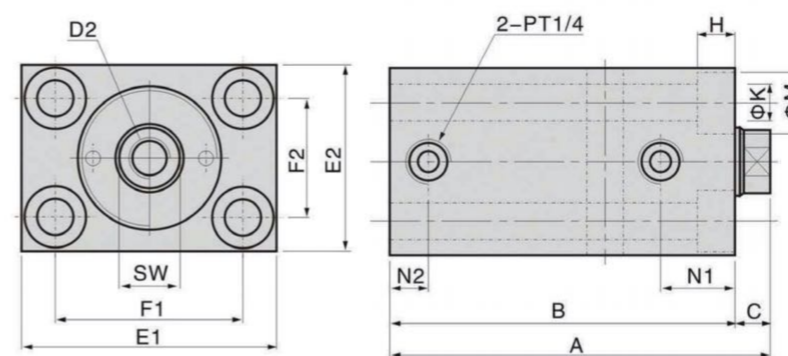
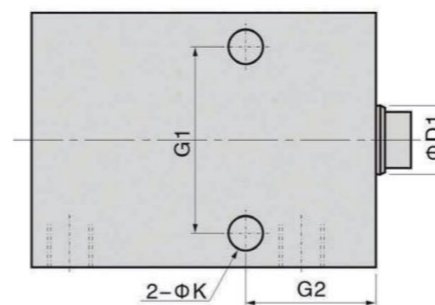

Dimension table Unit:mm

Bore	Φ16	Φ25	Φ32	Φ40	
Single acting	Stroke	8 20	8 20	10 20	10 20
	A	62 97	71 101	85 110	89 114
	B	56 91	64 94	75 100	79 104
Double acting	Stroke	16 50	20 50	25 50	25 50
	A	62 97	71 101	85 110	89 114
	B	56 91	64 94	75 100	79 104
C	6	7	10	10	
D1	10	16	20	25	
D2	M6×1.0 12Deep	M10×1.5 15Deep	M12×1.75 15Deep	M16×2.0 25Deep	
SW	8	13	17	22	
E1	60	65	75	85	
E2	35	45	55	63	
F1	40	50	55	63	
F2	22	30	35	40	
G1	30	50	55	63	
G2	30	33	38	40	
H	6.5	9	11	11	
K	6.8	9	11	11	
M	11	14	18	18	
N1	16.5	18	22	24	
N2	11	11	11	11	

### 规格参数表 SPECIFICATIONS

F1: 推出Push out F2: 拉入Pull in

油缸内径 HYDRAULIC CYLINDER INSIDE DIAMETER(mm)	活塞杆径 PISTON DIAMETER(mm)	受压面积 PRESSURE AREA(cm <sup>2</sup> )		操作压力 OPERATION PRESSURE(kgf/cm <sup>2</sup> )				使用流体 USABLE FLUID
		F1	F2	100		300		
Φ16	Φ10	2.01	1.22	201	122	603	366	相当于ISO黏度等级的ISO-VG-32一般液压油 Recommended: ISO-VG-32 hydraulic oil equivalent to ISO viscosity grade
Φ25	Φ16	4.91	2.9	491	290	1473	870	
Φ32	Φ20	8.04	4.9	804	490	2412	1470	
Φ40	Φ25	12.57	7.66	1257	766	3771	2298	

# CLSA

## 侧向夹紧器

## CLSA LATERAL CLAMPING DEVICE



### 产品特性

- 从侧向强力夹紧，传统的杠杆式夹紧器不能对应的侧向推压专用夹紧器。
1. 夹紧工件的侧面，适用于工件的侧向推移定位。
  2. 用于没有夹紧余量的工件。即使工件上没有夹紧位置或余量，也可以通过侧向夹紧来固定工件。
  3. 与旋转及杠杆式夹紧器相同的安装尺寸。如：CHA和CLKA
  4. 工件上部零干涉。因为可以从侧面夹紧工件，上方无干涉物，工件上面的加工更加方便。

最大操作压力: 70kgf/cm<sup>2</sup>  
最小操作压力: 5kgf/cm<sup>2</sup>

### FEATURES

- The traditional lever-type clamping device cannot be matched with the dedicated clamping device for lateral push clamping.
1. It clamps the side of the workpiece and is suitable for the lateral pushing and positioning of the workpiece.
  2. It is used for workpieces without clamping allowance. Even if there is no clamping position or allowance on the workpiece, the workpiece can still be fixed by lateral clamping.
  3. The same installation dimensions as rotary and lever clamps. For example: CHA and CLKA
  4. Zero interference at the upper part of the workpiece. Because the workpiece can be clamped from the side and there are no interfering objects above, the machining on the workpiece is more convenient.

Max. operating pressure: 70kgf/cm<sup>2</sup>  
Min. operating pressure: 5kgf/cm<sup>2</sup>

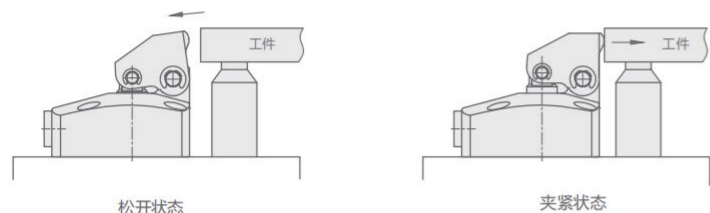

### 订购标示法 ORDERING INDICATION

示例: CLSA-036GR

CLSA	系列 Series	CLSA
036	主体尺寸 Body size	036: ØD36mm 040: ØD40mm ØD表示本体油缸外径尺寸 Outer diameter ØD of the cylinder
G	板式连接型 (附带G螺纹堵头) Gasket option(with G thread plug)	可安装速度控制阀 (CZL) (用户另行购买) A speed control valve can be installed, recommended CZL, please order separately.
R	压臂安装方向 Lever direction	L: 左 空白: 中间 R: 右 L: Left Blank: Center R: Right

### 规格参数表 SPECIFICATIONS

型号 MODEL	理论夹持力 CLAMPING FORCE AT 70 kgf/cm <sup>2</sup> (kgf)	全行程 TOTAL STROKE (mm)	夹紧行程 CLAMPING STROKE (mm)	行程余量 STROKE ALLOWANCE (mm)	推出受压面积 EFF-PISTON AREA CLAMP (cm <sup>2</sup> )	推出容积 (cm <sup>3</sup> ) CYLINDER CAPACITY CLAMP (cm <sup>3</sup> )	油缸内径 CYLINDER INSIDE DIAMETER (mm)	耐压 WITHSTANDING PRESSURE (MPa)	使用温度 RANGE OF TEMPERATURE (°C)
CLSA-036 □	266	3.5	2.5	1	3.80	1.33 1.05	Ø22	10.5	0~70
CLSA-040 □	343.7	3.5	2.5	1	4.91	1.72 1.32	Ø25	10.5	0~70

夹紧力计算公式 (kgf)  $F = 3.80 \times P$  P: 供给油压 (MPa) 使用流体: 相当于ISO黏度等级的ISO-VG-32一般液压油  
The clamping force calculation formula (kgf) P: Pressure (MPa)  
Usable fluid: Recommended: ISO-VG-32 hydraulic oil equivalent to ISO viscosity grade

### 外形尺寸 External Dimensions

※ 本图表示CLSA-036G/CLSA-040G的夹紧状态 (GL和GR,仅压板的安装方向不同)

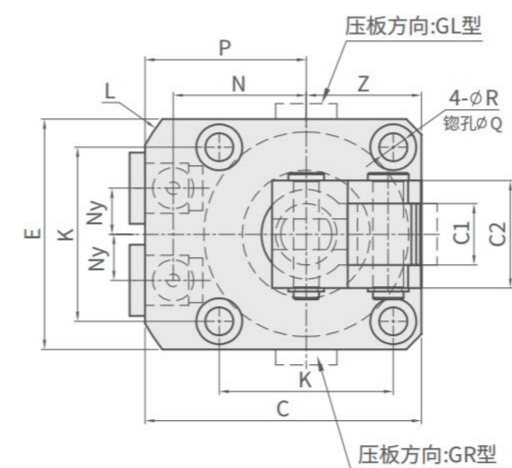
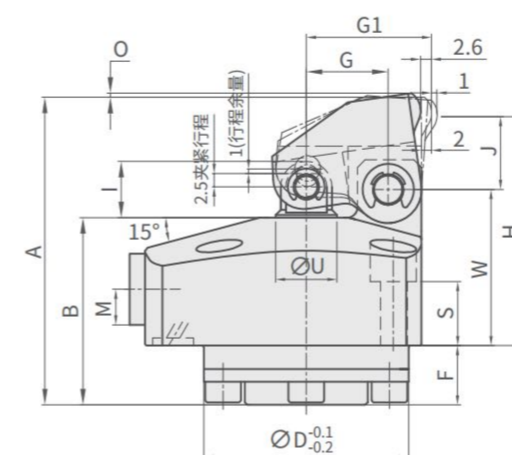
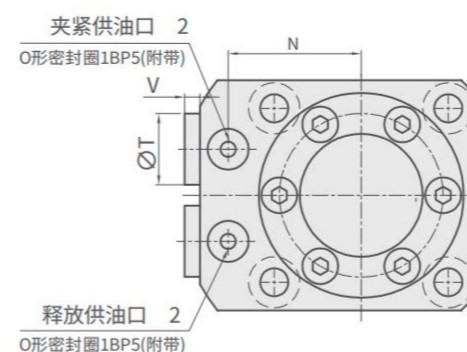

### 注意事项

1. 本产品未附带安装螺栓，请用户参照S尺寸高度自行配。
2. 本产品未附带速度控制阀，请用户另外配备。
3. 请参考F尺寸，并根据安装高度决定本体安装孔的深度。

### NOTES

- ※1. This product does not come with installation bolts. Users are requested to match them by referring to the S-sized height.
- ※2. This product does not come with a speed control valve. Please provide it separately.
- ※3. Please refer to the F dimension and determine the depth of the installation holes on the main body according to the installation height.

### 外形尺寸表

Unit:mm

型号 MODEL NO	CLSA-036 □	CLSA-040 □
A	55	60
B	33	36.6
C	49	54
D	36	40
D1	5	6
D2	5	6
E	40	45
F	8	11.6
G	14.5	16
G1	22	24.5
H	45	45
I	12.5	11
J	15	14.5
K	31.4	34
L	66	72
M	11	11
N	23.5	26
Ny	8	9
O	0.9	0.8
P	29	31.5
Q	7.5	9
R	4.5	5.5
S	15.5	15
T	14	14
V	4	4
U	10	12
W	30	30.5
X	36	40
C1	10	12
C2	19	21
FF	9	13
EE	M4	M5
夹紧供油口:G螺纹	G1/8	G1/8
释放供油口:G螺纹	G1/8	G1/8
O型密封圈	P5	P5

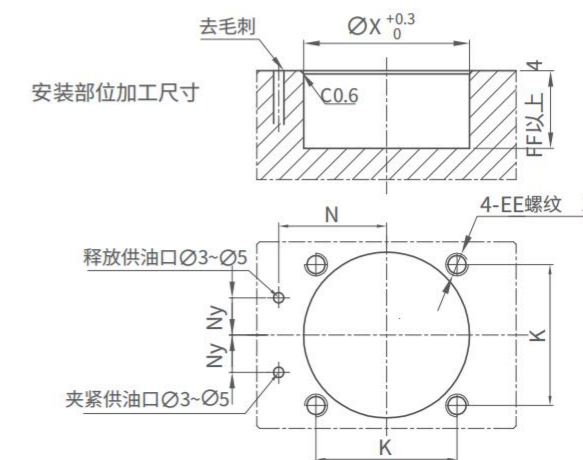

# CTLZ

## 下拉式涨紧缸

## CTLZ PULL-DOWN TENSIONING CYLINDER



### 产品特性

- 1、外形紧凑，可同时容纳或搭配多种缸类使用。
- 2、缸体采用硬化处理，重复定位精度高。
- 3、适用场景范围广，可应用于金属或非金属切削领域。
- 4、夹套搭配硫化橡胶材质，涨缩效果及防尘效果佳。
- 5、夹套大小及相关尺寸，可根据客户需求定制。
- 6、配合客户油压系统的使用，可提供较大及稳定的轴向下拉力及侧向剪切力。

### FEATURES

1. Compact in design, it can accommodate or be used in combination with multiple types of cylinders simultaneously.
2. The cylinder body is hardened, ensuring high repeat positioning accuracy.
3. It has a wide range of applicable scenarios and can be used in both metal and non-metal cutting fields.
4. The collect is inlaid with vulcanized rubber, providing excellent expansion and contraction effects as well as dust-proof performance.
5. The size of the collect and related dimensions can be customized according to customer requirements.
6. In conjunction with the customer's hydraulic system, it can provide a large and stable downward axial tensile force and lateral shear force.

### 订购标示法 ORDERING INDICATION

#### 示例: CTLZ-2028

CTLZ	系列 Series	CTLZ
2028	规格 Spec	2028/2638/3654/5080/69120

注：此标示法仅为缸体部份，涨套尺寸依客户需求，另行订购及制作。

Note: The ordering indication only applies to the cylinder body part. The size of the expansion sleeve will be ordered and manufactured separately according to customer requirements.

### 下拉式涨紧缸尺寸

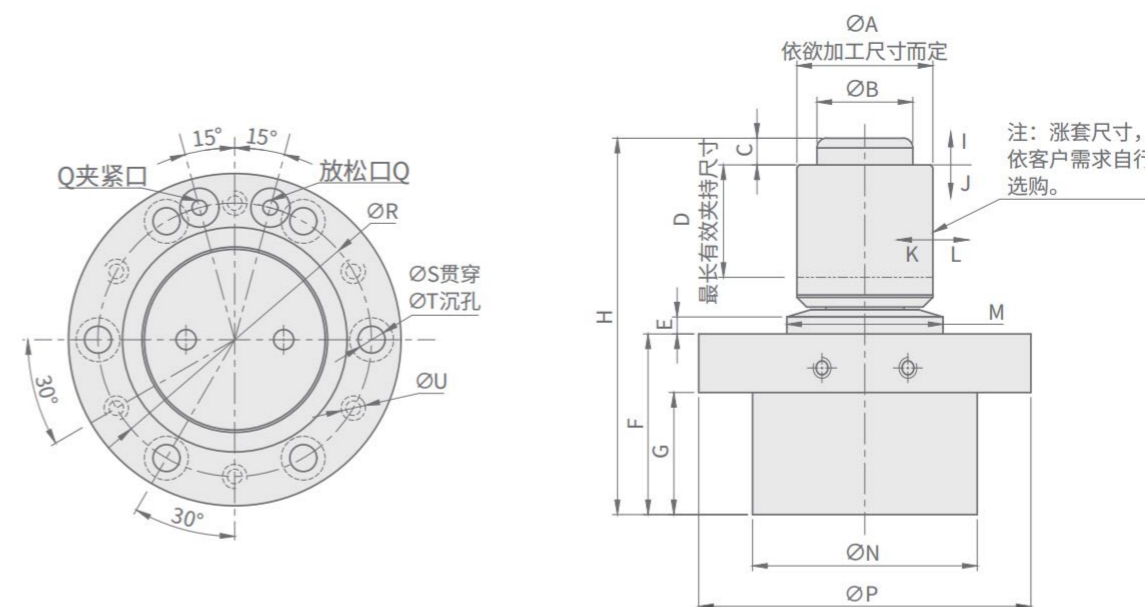

### 下拉式涨紧缸规格参数表

注：涨套尺寸，依客户需求自行选购。

CTLZ-2028			
编号/类型	单位	尺寸	备注
A 夹持范围	mm	Ø20~Ø28	在Ø20~Ø28之间可依客户加工孔径来定制
B 最大拉杆直径	mm	<A尺寸0.4	
C 拉杆高度	mm	5.5	
D 夹持长度	mm	23	要求最短夹持长度5mm以上
E 长度	mm	3.5	
F 长度	mm	37	
G 长度	mm	25	
H 总高	mm	78	
I 轴向松开行程	mm	1.5	
J 轴向夹紧行程	mm	2	
K 径向松开行程	mm	单边0.1	松开总行程0.2mm
L 径向夹紧行程	mm	单边0.1	夹紧总行程0.2mm
M 链接直径	mm	32f7	
N 安装直径	mm	46h6	
P 外直径	mm	68	
Q O形圈	密封圈	P5	
R 参考圆直径	mm	56	
S 贯穿孔	mm	6-Ø5.5	均匀分布
T 沉孔	mm	6-Ø9沉孔5.5	均匀分布
U 螺纹孔	mm	6-M5牙深8	
最大使用液压力	MPa	18	
最大轴向拉力	KN	8	
最大径向夹持力	KN	32	
重复定位精度	mm	≤0.01	

### 下拉式涨紧缸规格参数表

注：涨套尺寸，依客户需求自行选购。

CTLZ-2638			
编号/类型	单位	尺寸	备注
A 夹持范围	mm	Ø26~Ø38	在Ø26~Ø38之间可依客户加工孔径来定制
B 最大拉杆直径	mm	<A尺寸0.4	
C 拉杆高度	mm	5.5	
D 夹持长度	mm	27	要求最短夹持长度5mm以上
E 长度	mm	3.5	
F 长度	mm	37	
G 长度	mm	25	
H 总高	mm	83	
I 轴向松开行程	mm	1.5	
J 轴向夹紧行程	mm	2	
K 径向松开行程	mm	单边0.1	松开总径程0.2mm
L 径向夹紧行程	mm	单边0.1	夹紧总径程0.2mm
M 链接直径	mm	36f7	
N 安装直径	mm	52h6	
P 外直径	mm	74	
Q O形圈	密封圈	P5	
R 参考圆直径	mm	63	
S 贯穿孔	mm	6-Ø5.5	均匀分布
T 沉孔	mm	6-Ø9沉孔5.5	均匀分布
U 螺纹孔	mm	6-M5牙深8	
最大使用液压力	MPa	18	
最大轴向拉力	KN	10	
最大径向夹持力	KN	40	
重复定位精度	mm	≤0.01	

CTLZ-3654			
编号/类型	单位	尺寸	备注
A 夹持范围	mm	Ø36~Ø54	在Ø36~Ø54之间可依客户加工孔径来定制
B 最大拉杆直径	mm	<A尺寸0.4	
C 拉杆高度	mm	6	
D 夹持长度	mm	44	要求最短夹持长度5mm以上
E 长度	mm	3.5	
F 长度	mm	42	
G 长度	mm	30	
H 总高	mm	107.5	
I 轴向松开行程	mm	2	
J 轴向夹紧行程	mm	2.5	
K 径向松开行程	mm	单边0.15	松开总径程0.3mm
L 径向夹紧行程	mm	单边0.15	夹紧总径程0.3mm
M 链接直径	mm	52f7	
N 安装直径	mm	62h6	
P 外直径	mm	86	
Q O形圈	密封圈	P5	
R 参考圆直径	mm	73	
S 贯穿孔	mm	6-Ø6.5	均匀分布
T 沉孔	mm	6-Ø10.5沉孔6.5	均匀分布
U 螺纹孔	mm	6-M6牙深10	
最大使用液压力	MPa	18	
最大轴向拉力	KN	20	
最大径向夹持力	KN	80	
重复定位精度	mm	≤0.01	

### 下拉式涨紧缸规格参数表

注：涨套尺寸，依客户需求自行选购。

CTLZ-5080			
编号/类型	单位	尺寸	备注
A 夹持范围	mm	Ø50~Ø80	在Ø50~Ø80之间可依客户加工孔径来定制
B 最大拉杆直径	mm	<A尺寸0.4	
C 拉杆高度	mm	6	
D 夹持长度	mm	50	要求最短夹持长度7mm以上
E 长度	mm	3.5	
F 长度	mm	46	
G 长度	mm	32	
H 总高	mm	121.8	
I 轴向松开行程	mm	2	
J 轴向夹紧行程	mm	2.5	
K 径向松开行程	mm	单边0.15	松开总径程0.3mm
L 径向夹紧行程	mm	单边0.15	夹紧总径程0.3mm
M 链接直径	mm	60f7	
N 安装直径	mm	70h6	
P 外直径	mm	94	
Q O形圈	密封圈	P5	
R 参考圆直径	mm	80	
S 贯穿孔	mm	6-Ø6.5	均匀分布
T 沉孔	mm	6-Ø10.5沉孔6.5	均匀分布
U 螺纹孔	mm	6-M6牙深10	
最大使用液压力	MPa	18	
最大轴向拉力	KN	25	
最大径向夹持力	KN	100	
重复定位精度	mm	≤0.01	

CTLZ-69120			
编号/类型	单位	尺寸	备注
A 夹持范围	mm	Ø69~Ø120	在Ø69~Ø120之间可依客户加工孔径来定制
B 最大拉杆直径	mm	<A尺寸0.4	
C 拉杆高度	mm	7	
D 夹持长度	mm	65	要求最短夹持长度7mm以上
E 长度	mm	3.5	
F 长度	mm	48	
G 长度	mm	33	
H 总高	mm	141.2	
I 轴向松开行程	mm	2	
J 轴向夹紧行程	mm	2.5	
K 径向松开行程	mm	单边0.15	松开总径程0.3mm
L 径向夹紧行程	mm	单边0.15	夹紧总径程0.3mm
M 链接直径	mm	80f7	
N 安装直径	mm	86h6	
P 外直径	mm	112	
Q O形圈	密封圈	P5	
R 参考圆直径	mm	98	
S 贯穿孔	mm	6-Ø6.5	均匀分布
T 沉孔	mm	6-Ø10.5沉孔6.5	均匀分布
U 螺纹孔	mm	6-M6牙深10	
最大使用液压力	MPa	18	
最大轴向拉力	KN	30	
最大径向夹持力	KN	120	
重复定位精度	mm	≤0.01	

# CFP

## 油压钢球锁紧下拉缸

## CFP HYDRAULIC PULL STUD CLAMP



### 产品特性

使用工件的通孔或螺纹孔，下拉牵引螺栓的油缸。除着座面外，一次装卡就可实现5面加工（工序集约化）

低压（1~7MPa）  
单动式

### FEATURES

Pulling clamp using pull-bolt for workpiece through hole or screw hole. Five sided surface machining is possible for workpiece. (This drastically reduces the number of operations needed.)

Low pressure (1~7MPa)  
Single acting

### 订购标示法 ORDERING INDICATION

#### 示例: CFP-39G

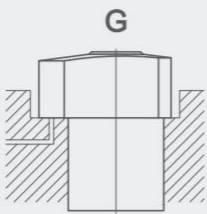
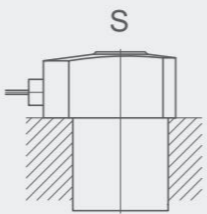
CFP	系列 Series	CFP
39	油缸外径 Body Size	39: $\Phi D=39\text{mm}$ 55: $\Phi D=55\text{mm}$ 65: $\Phi D=65\text{mm}$ 75: $\Phi D=75\text{mm}$ 90: $\Phi D=90\text{mm}$
G	配管方式 Piping Method	 G: 板式速接型 (配有R螺纹堵头)  S: 外配管型 (Rc螺纹)

### 外形尺寸 External Dimensions

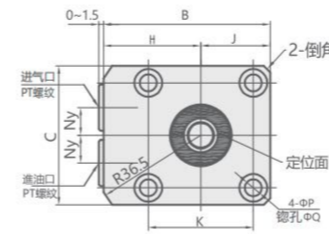
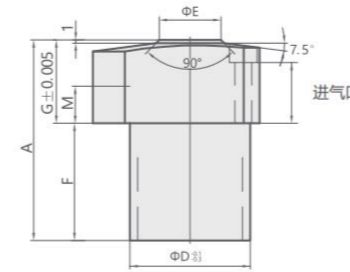
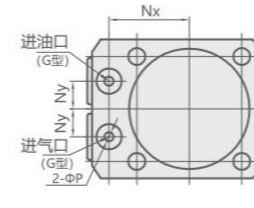

### 安装部位加工尺寸 Machining Dimensions of Mounting Area

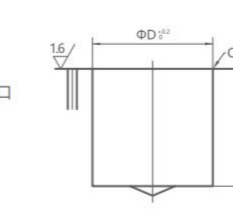
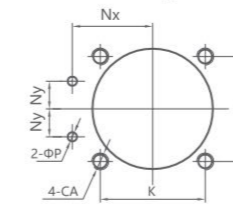

### 注意事项:

- ※1. R螺纹堵头的突出量存在0~1.5mm的差异。
  - ※2. 本产品未附带安装螺栓。
  - ※3. 请参考S尺寸，并根据安装高度决定安装螺栓用CA螺纹深度。
  - ※4. 请参考F尺寸，并根据安装高度决定本体安装孔中ΦD的深度。
  - ※5. 本加工表示G:板式连接时的情况。
  - ※6. 使用流体:相当于ISO粘度等级的ISO-VG-32一般液压油。
- 请用户参照S尺寸并根据安装高度自行配备

### Notes

- ※1. The protrusion of R thread plug is between 0 to 1.5 mm.
  - ※2. Mounting bolts are not provided.
  - ※3. The CA thread depth for mounting bolts is to be decided by the customer according to the mounting height using the S dimensions as a reference.
  - ※4. The depth of diameter  $\Phi D$  for the mounting hole on the unit should be decided by customer according to the mounting height using the F dimensions as a reference.
  - ※5. This machining drawing shows G: Gasket option.
  - ※6. Usable fluid: General Hydraulic Oil Equivalent to ISO-VG-32.
- Prepare mounting bolts according to the mounting height. Please refer to S dimensions.

### 规格参数表 SPECIFICATIONS

型号	油缸夹侧面积	夹紧力 (计算公式)※1	全行程	夹紧行程	油缸夹侧容量	释放弹簧力	导套复位弹簧力	容许偏心量	最高使用压力	最低动作压力	耐压	推荐气压 (喷气清洁用)	使用温度	重量
MODEL	CYLINDER AREA FOR LOCKING (cm <sup>2</sup> )	CLAMPING FORCE (CALCULATION FORMULA)※1 (N)	FULL STROKE (mm)	LOCK STROKE (mm)	CYLINDER CAPACITY (LOCK SIDE) (cm <sup>3</sup> )	RELEASE SPRING FORCE (N)	SLEEVE RETURN SPRING FORCE (N)	ALLOWABLE OFFSET (mm)	MAX. OPERATING PRESSURE (MPa)	MIN. OPERATING PRESSURE (MPa)	WITHSTANDING PRESSURE (MPa)	Withstanding Pressure (MPa)	OPERATING TEMPERATURE (°C)	WEIGHT (kg)
CFP-39	6.0	$F=0.60 \times P-0.20$	6.7	3.8	4.0	116~215	6.1	±0.5	7.0	1.0	10.5	0.4~0.5	0~70	0.7
CFP-55	9.9	$F=0.99 \times P-0.29$	7.5	5	7.4	198~318	9.3	±0.7	7.0	1.0	10.5	0.4~0.5	0~70	1.5
CFP-65	15.7	$F=1.57 \times P-0.42$	8.5	5.3	13.4	306~475	11.3	±1	7.0	1.0	10.5	0.4~0.5	0~70	2.3
CFP-75	23.3	$F=2.33 \times P-0.69$	10	7	23.3	459~763	18.0	±1	7.0	1.0	10.5	0.4~0.5	0~70	3.5
CFP-90	36.4	$F=3.64 \times P-1.10$	12	8.7	43.7	733~1214	21.6	±1.2	7.0	1.0	10.5	0.4~0.5	0~70	6.0

注意事项※1. 在夹紧力(计算公式)中, 符号F: 夹紧力(KN)、P: 供给液压(MPa)。

Note ※1. Clamping force (Calculation formula) symbols show F: Clamping Force (KN), P: Supply Hydraulic Pressure (MPa).

Unit:mm

型号 Model No	CFP-39	CFP-55	CFP-65	CFP-75	CFP-90
全行程 Full Stroke Y	6.7	7.5	8.5	10	12
夹紧行程 Clamping Stroke	3.8	5	5.3	7	8.7
A	65	74	85	100	120
B	54	69	81	92	107
C	45	60	70	80	95
D	39	55	65	75	90
E	20	25	30	38	47.5
F	38	47	57	68	83
G	27	27	28	32	37
H	31.5	39	46	52	59.5
J	22.5	30	35	40	47.5
K	34	47	55	63	75
L	73	88	106	116	136
M	12	12	12	16	16
Nx	26	33.5	39.5	45	52.5
Ny	9	12	15	16	18.5
P	3	3	5	5	5
Q	9	11	11	14	17.5
R	5.5	6.8	6.8	9	11
S	18.5	16.5	17	19	21
倒角 Chamfer	3	3	4	5	6
CA (Nominal×Pitch)	M5×0.8	M6×1.0	M6×1.0	M8×1.25	M10×1.25
供油口 Hydraulic Port Rc 螺纹 (Rc-Thread)	Rc1/8	Rc1/8	Rc1/8	Rc1/4	Rc1/4
喷气清洁用供气口 Air Blow Port Rc 螺纹 (Rc-Thread)	Rc1/8	Rc1/8	Rc1/8	Rc1/4	Rc1/4
冷却液排出口 Coolant Discharge Port Rc 螺纹 (Rc-Thread)	Rc1/8	Rc1/8	Rc1/8	Rc1/4	Rc1/4
O形密封圈 O-ring G型 G option	1BP5	1BP5	1BP7	1BP7	1BP7
R 螺纹堵头 R-Thread Plug	R1/8	R1/8	R1/8	R1/4	R1/4

选配项: 牵引螺栓  
Accessories: Pull Bolt

CLZ - 39 - CFP1

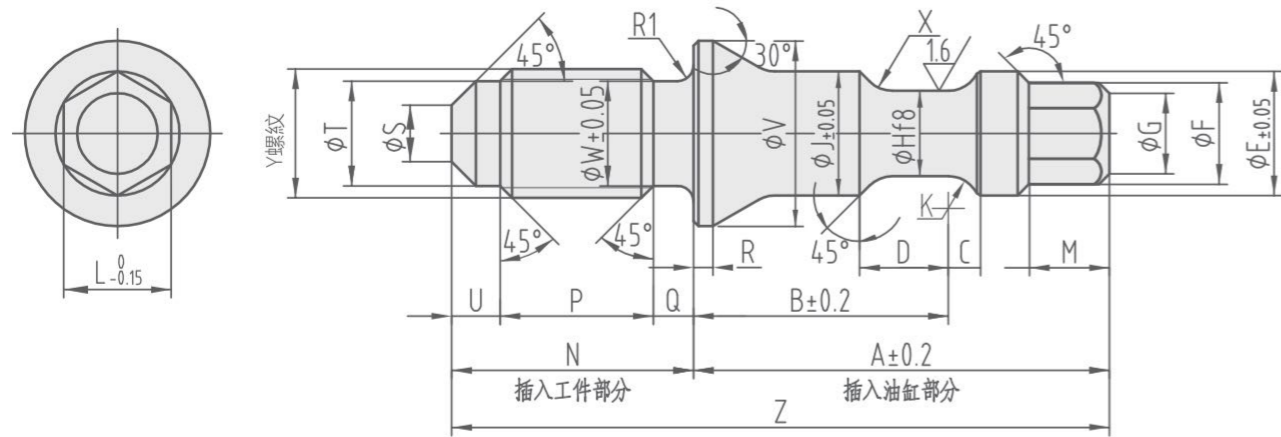

Unit:mm

大于 Greater than	小于 less than	公差 Tolerance
-	6	±0.1
6	30	±0.2
30	120	±0.3

注意事项

1. 牵引螺栓 (CLZ-CFP1) 的设计应满足油缸着座面与工件底面间隙在0(密接)~0.3mm以内。
2. 设计制作牵引螺栓时, 请参考本图。·无公差尺寸表示的请按右表的要求进行加工

Notes

1. When using CLZ-CFP1 pull bolt, the space between the top of the clamp and the bottom of the work piece must be 0 (firm contact) to 0.3 mm
2. Refer to this figure when manufacturing pull bolts.· Dimensions for clamp mounting must be strictly followed. If tolerance is not specified, dimensions should refer to the graph on the right.

型号 Model	CLZ-39 -CFP1	CLZ-55 -CFP1	CLZ-65 -CFP1	CLZ-75 -CFP1	CLZ-90 -CFP1
对机器型号 Corresponding Product Model	39	55	65	75	90
A	25.8	30	35.5	45	56
B	15.8	18	21.5	27	33.5
C	2	2.6	3	3.8	5
D	5.5	7.5	8	10.5	12.5
E	7.7	9.7	11.5	14.5	18.5
F	6.3	9.1	9.1	11.3	14.8
G	5	7.5	7.5	9.5	12.2
H	5.3 <sup>-0.010</sup> <sub>-0.028</sub>	6.5 <sup>-0.013</sup> <sub>-0.035</sub>	8 <sup>-0.013</sup> <sub>-0.035</sub>	10 <sup>-0.013</sup> <sub>-0.035</sub>	12.5 <sup>-0.016</sup> <sub>-0.043</sub>
J	7.7	9.7	11.5	14.5	18.5
K	R2	R2.5	R3	R3.75	R4.76
L	5.5	8	8	10	13
M	5	7	7	8.5	11
N	15	18	20	26	33
P	9.5	12	13.5	18	22
Q	2.5	2.5	2.5	3	4
R	1.2	1.2	1.5	2	2.5
S	3.5	4	5	7	8.5
T	6.5	8.2	10	13.5	17
U	3	3.5	4	5	7
V	11.5	13.5	16	21	26
W	6.5	8.2	10	13.5	17
X	R2	R2.5	R3	R4	R5
Y (标称×间距) (Nominal×Pitch)	M8×1.25	M10×1.5	M12×1.75	M16×2	M20×2.5
Z	40.8	48	55.5	71	89

# CYTH

单动型直线油压缸

## CYTH SINGLE ACTING HYDRAULIC CYLINDER



产品特性

使用压力范围: 3~25MPa(启动压力是3MPa)  
使用温度范围: -10 ~ +60(°C)  
工作流体: 滤清之标准液压油

SPECIFICATIONS

The range of pressure(MPa): 3~25MPa  
Range of temperature(°C): -10 ~ +60(°C)  
Usable Fluid: Filtered oil

订购标示法 ORDERING INDICATION

示例: CYTH-ZS/TB-25/210

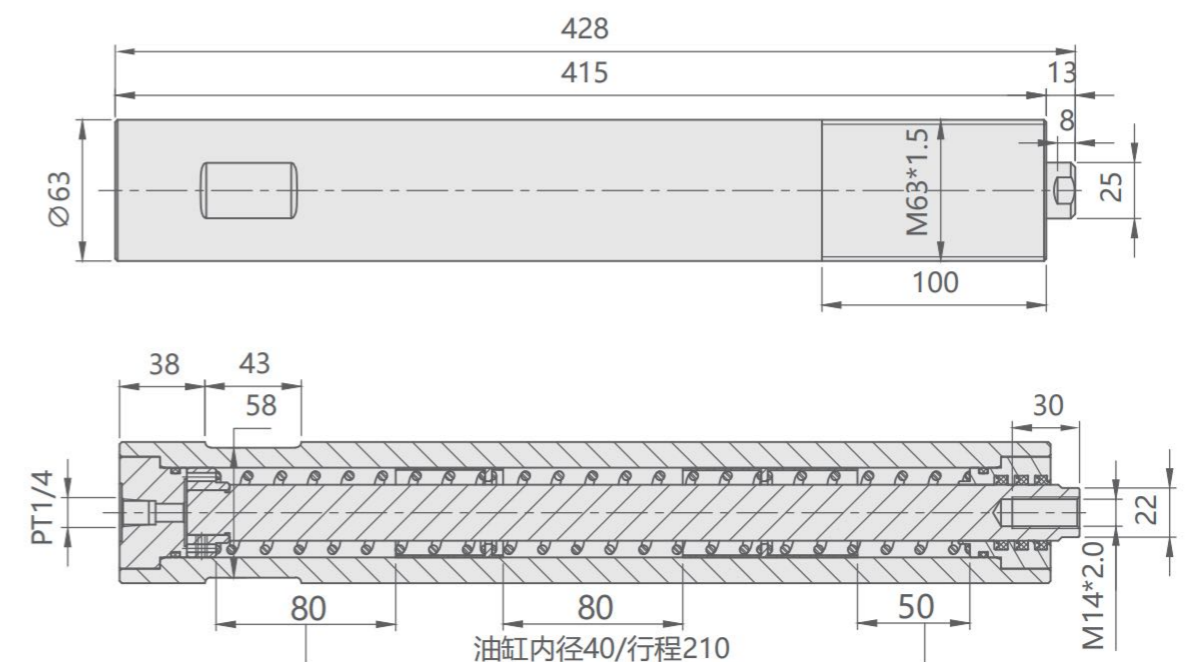

# CZP

## 零点定位器

### CZP ZERO POINT SYSTEM



#### 产品特点:

- 气、油压解锁，弹簧机械锁紧
- 材质:硬化不锈钢。
- 表面及活塞硬化处理。
- 重复定位精度<0.005mm。
- 拉紧力及夹紧力大。
- 使用时可切断压力源，夹紧力稳定。

#### FEATURES

- Released by air/oil pressure, locked by spring
- Material: Harden stainless steel
- Surface and piston hardening treatment
- Repeatability <0.005mm
- High clamping force, high tension force
- The system maintains stable clamping force even when air pressure is disconnected during use.

#### 使用行业:

- 适用于需减少夹具更换时间的加工行业
- 适用于金属或非金属切削领域。

#### INDUSTRY OF USE

- It is suitable for processing industries that need to reduce the time for fixture replacement.
- It is applicable to the cutting fields of metals or non-metals.

#### 订购标示法 ORDERING INDICATION

##### 示例: CZPO -20M

<b>CZPO</b>	系列 Series	CZP 气压解锁式零点定位器 CZPO 油压解锁式零点定位器
<b>20</b>	规格 Specs	05, 10, 20, 40
<b>M</b>	功能Function	空白: 标准 M: 含有气检功能 Blank: Standard M: Air sensing type

\*零点定位器必须与相应的附件共同配合使用，方能达到定位功能。  
\*The zero-point positioner must be used in conjunction with the corresponding accessories to achieve the positioning function.  
\*气检功能，只有CZP-20M及CZP-40M二种规格。  
\* Only two types have air sensing functions: CZP-20M and CZP-40M

#### 零点定位尺寸 ZERO POINT POSITIONING SIZE

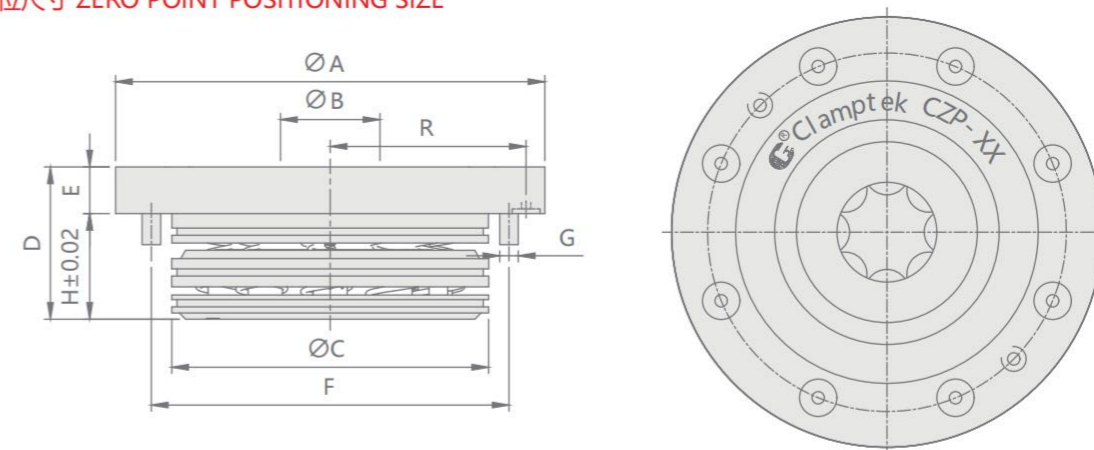

#### 规格参数表 SPECIFICATION

型号	外径ØA mm	销孔ØB mm	安装外径ØC mm	总高D mm	本体厚度E mm	安装孔直径ØF mm	安装螺栓G mm	安装高度H mm	气/油孔半径R mm	解锁方式 MPa	夹紧力 KN	拉紧力 KN
CZP-05	78	18	58	30	8.5	65	8xM4	21.5	35	气压(0.55~1.2)	4	13
CZPO-05										油压(2.5~4.0)	7	13
CZP-10	112	22	78	35	10.0	92	8xM6	25.0	48	气压(0.55~1.2)	6	25
CZPO-10										油压(2.5~4.0)	11	25
CZP-20	138	32	102	49	15.0	115	8xM6	34.0	63	气压(0.55~1.2)	11	55
CZPO-20										油压(2.5~4.0)	15	55
CZP-40	172	40	127	63	18.0	143	8xM8	45.0	77	气压(0.60~1.2)	16	105
CZPO-40										油压(2.5~4.0)	25	105

#### 零点定位安装示意图

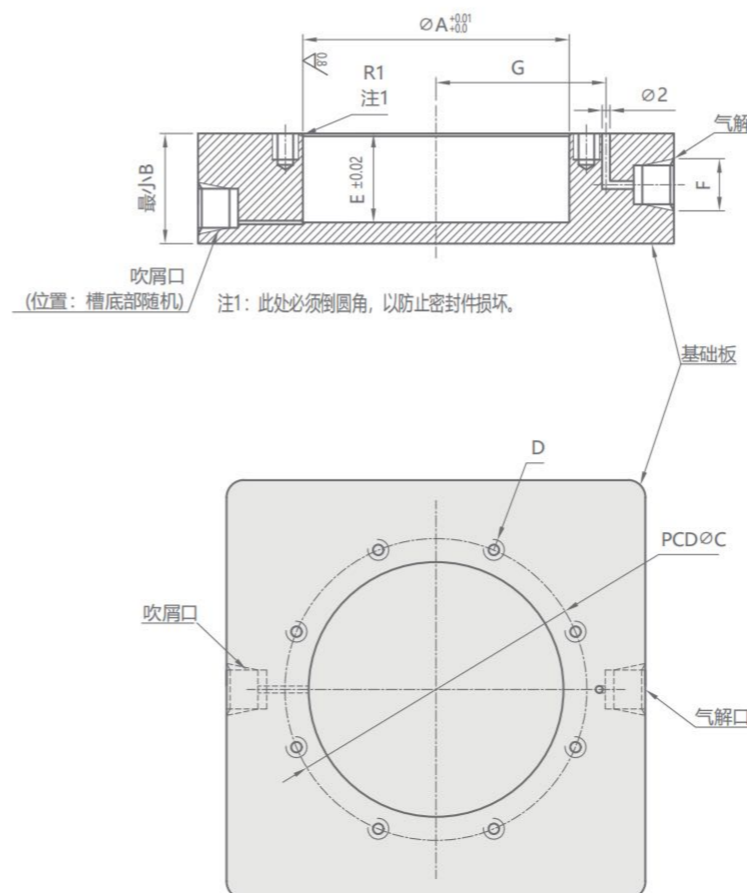

#### 零点定位器安装孔规格参数表

型号	安装外径ØA mm	最小板高B mm	安装孔直径ØC mm	安装螺栓D mm	安装高度E mm	孔径F mm	气孔半径G mm
CZP-05	55	25	65	8xM4	21.5	PT1/8	35
CZPO-05							
CZP-10	78	32	92	8xM6	25.0	PT1/8	48
CZPO-10							
CZP-20	102	38	115	8xM6	34.0	PT1/4	63
CZPO-20							
CZP-40	127	52	143	8xM8	45.0	PT1/4	77
CZPO-40							

# CZP定位器附件

## CZP ACCESSORIES PART



### 订购标示法 ORDERING INDICATION

示例: CZP-20L

CZP	系列 Series	零点定位器		
20	规格 Specs	05, 10, 20, 40		
L	附件类型 Accessory Types	L:定位销 D:定向销 S:紧固螺栓	F:锁紧销 E:保护销	L: Positioning pin D: Directional pin S: Fastening bolt F: Locking pin E: Protective pin

### 定位销产品特点:

- 精度高, 硬化处理。
- 起到限制X、Y方向自由的作用。

### POSITIONING PIN FEATURES

- Positioning pin with high precision, hardening treatment.
- Restriction of freedom in X - and Y-axis directions

### 紧固螺栓产品特点:

- 强度12.9级。

### FASTENING BOLT FEATURES

- Strength: 12.9 grade

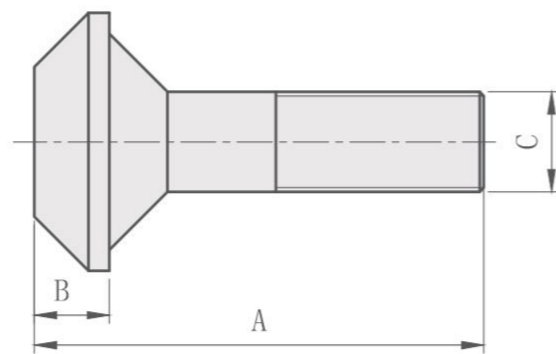
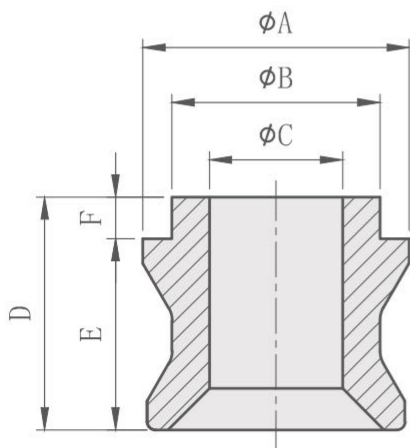

### 规格参数表 SPECIFICATION PARAMETER TABLE

型号	外径 $\phi A$	定位外径 $\phi B$	螺栓孔径 $\phi C$	总高D	厚度E	高度F
CZP-05L	18	14	8.2	15.5	12.8	2.7
CZP-10L	22	15	8.2	19.3	16.3	3.0
CZP-20L	32	25	12.2	28.0	23.0	5.0
CZP-40L	40	30	16.2	34.0	29.0	5.0

注:材质及尺寸可依客户要求定制。

### 规格参数表 SPECIFICATION PARAMETER TABLE

型号	总长A	螺栓高度B	螺纹C
CZP-05S	30	5	M8
CZP-10S	37	6	M8
CZP-20S	50	8	M12
CZP-40S	65	10	M16

注:材质及尺寸可依客户要求定制。

### 定向销产品特点:

- 硬化处理。
- 只限制旋转自由, 起到定向的作用。
- 导向孔与定位边的角度为 $90^\circ$ 。

### DIRECTIONAL PIN FEATURES

- Hardening treatment
- Limit the degree of freedom of rotation and play a directional role
- The Angle between the guide hole and the positioning side is  $90^\circ$

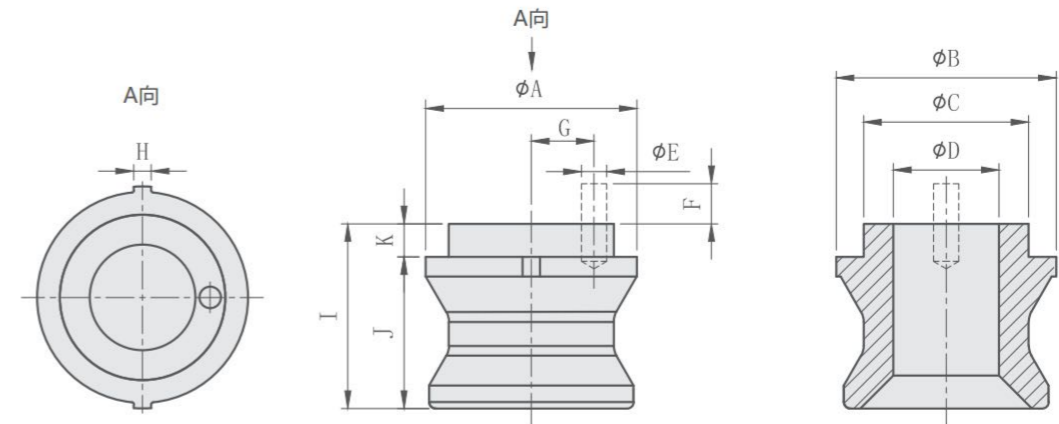

### 规格参数表 SPECIFICATION PARAMETER TABLE

型号	外径 $\phi A$	凸圆外径 $\phi B$	定位外径 $\phi C$	螺栓孔径 $\phi D$	销孔直径 $\phi E$	销钉高度F	销孔距离G	凸圆宽度H	总高I	厚度J	高度K
CZP-05D	17.6	18	14	8.2	2.0	3	5.5	1.4	15.5	12.8	2.7
CZP-10D	21.6	22	15	8.2	2.0	3	5.75	2.0	19.3	16.3	3.0
CZP-20D	31.6	32	25	12.2	3.0	4	9.0	2.6	28.0	23.0	5.0
CZP-40D	39.6	40	30	16.2	3.0	4	11.5	4.4	34.0	29.0	5.0

Unit:mm

### 锁紧销产品特点:

- 硬化处理, 起到增加拉紧力的作用。
- 保证托盘完全定位, 避免过定位。

### LOCKING PIN FEATURES

- Hardening treatment to increase the role of tension
- Ensure that the tray is fully positioned to avoid over-positioning

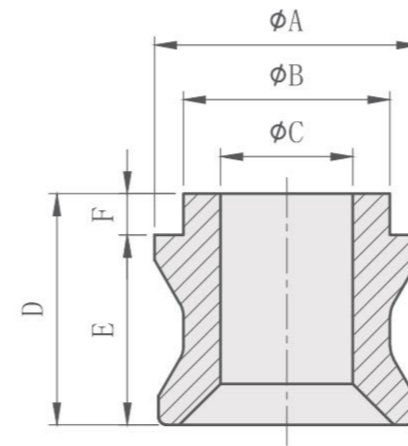

### 保护销产品特点:

- 材质:铁。
- 防止杂物进入未工作的零点定位单元。
- O环, 出货时附带。

### PROTECTIVE PIN FEATURES

- Material: Steel
- Prevents debris from entering the non-working zero position unit
- O-ring included

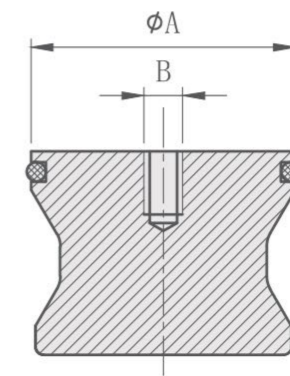

### 规格参数表 SPECIFICATION PARAMETER TABLE

型号	外径 $\phi A$	定位外径 $\phi B$	螺栓孔径 $\phi C$	总高D	厚度E	高度F
CZP-05F	17.8	14	8.2	15.5	12.8	2.7
CZP-10F	21.8	15	8.2	19.3	16.3	3.0
CZP-20F	31.8	25	12.2	28.0	23.0	5.0
CZP-40F	39.8	30	16.2	34.0	29.0	5.0

注:材质及尺寸可依客户要求定制。

### 规格参数表 SPECIFICATION PARAMETER TABLE

型号	外径 $\phi A$	螺纹孔B
CZP-05E	17.8	M5
CZP-10E	21.8	M6
CZP-20E	31.8	M6
CZP-40E	39.8	M8

注:材质及尺寸可依客户要求定制。

# 零点定位器基础板

## CZP ZERO POINT LOCATOR BASE PLATE

### 订购标示法 ORDERING INDICATION

示例: CZP-20B-002

<b>CZP</b>	系列 Series	零点定位器
<b>20</b>	规格 Specs	05, 10, 20, 40
<b>B</b>	类型 Types	B:基础板
<b>002</b>	型式 Option	002, 004, 006, 008, Q04 注:其他型式可依客户要求定制

Note: Other options can be customized according to customer requirements

### ● 2单元基础板尺寸

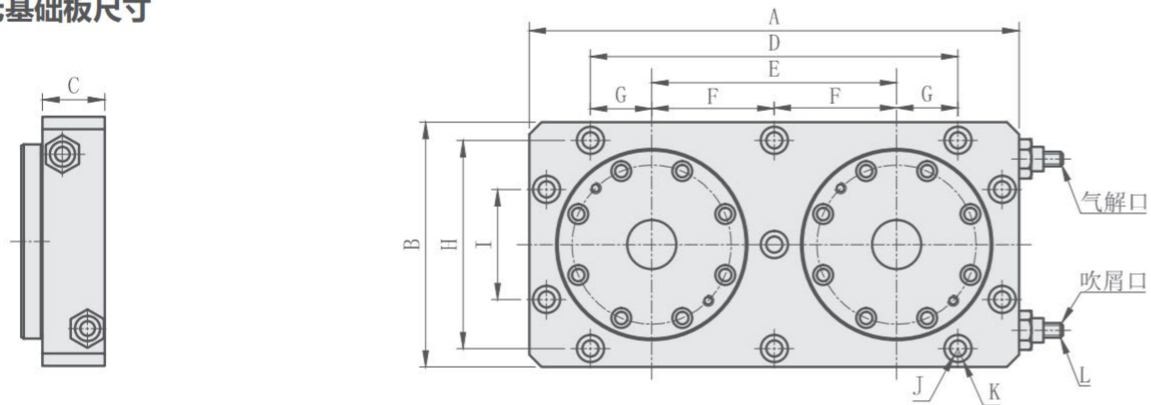

### 规格参数表 SPECIFICATION PARAMETER TABLE

型号	板长A	板宽B	板高C	孔距D	中心距E	孔距F	孔距G	孔距H	孔径I	直径ΦJ	直径ΦK*深	孔径L
CZP-05B-002	200	100	25	186	100	50	25	85	45	Φ6.5	Φ11*7	PT1/8

### ● 2单元基础板尺寸

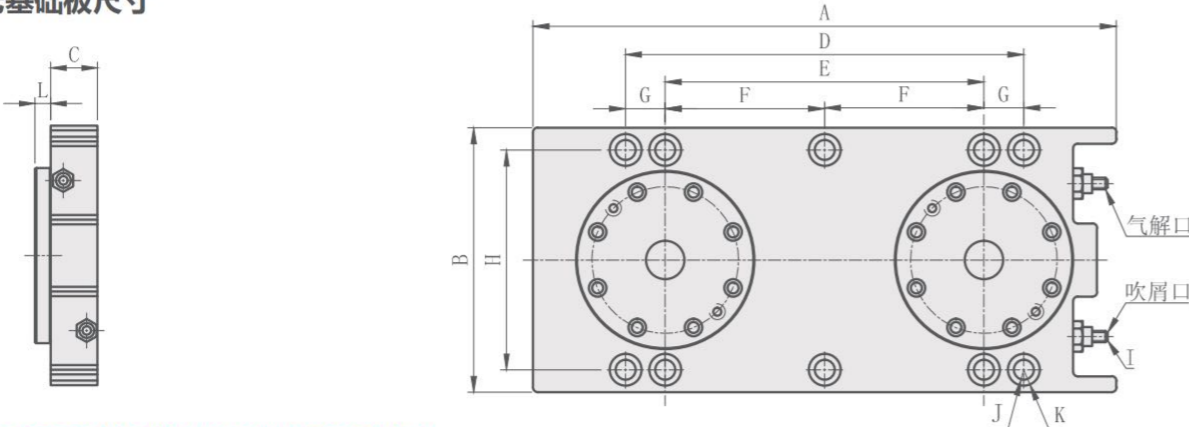

### 规格参数表 SPECIFICATION PARAMETER TABLE

型号	板长A	板宽B	板高C	孔距D	中心距E	孔距F	孔距G	孔距H	孔径I	直径ΦJ	直径ΦK*深	本体高L
CZP-10B-002	366	166	30	250	200	100	25	138	PT1/8	Φ12.5	Φ20*13	10
CZP-20B-002	398	198	38	250	200	100	25	164	PT1/4	Φ12.5	Φ20*13	15
CZP-40B-002	398	223	52	250	200	100	25	195	PT1/4	Φ12.5	Φ20*13	18

### ● 4单元基础板尺寸

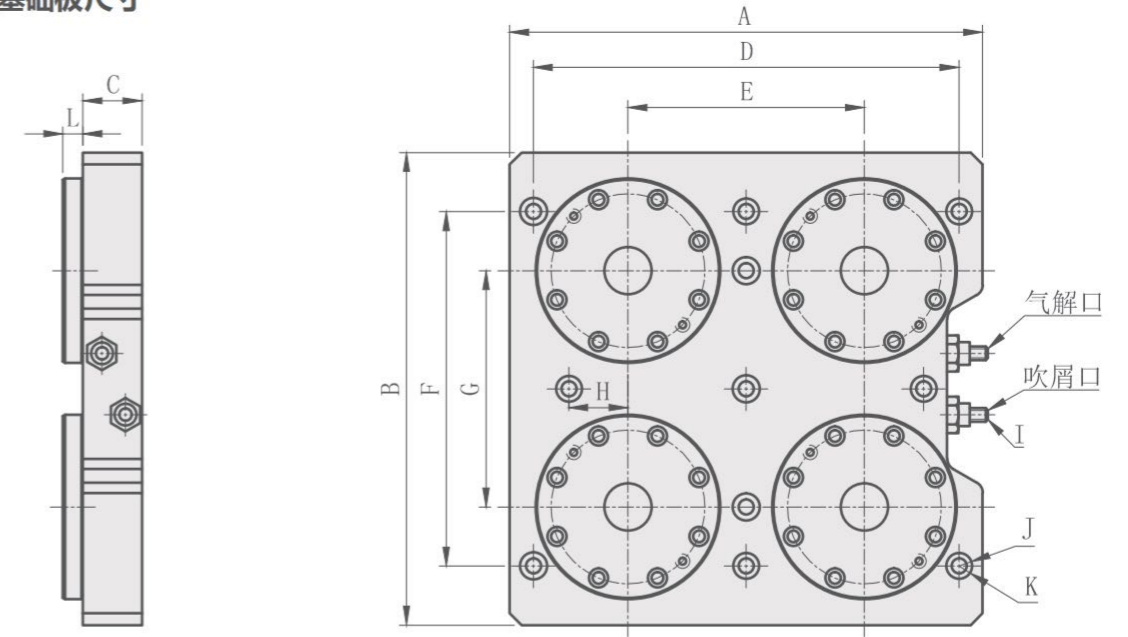

### 规格参数表 SPECIFICATION PARAMETER TABLE

型号	板长A	板宽B	板高C	孔距D	中心距E	孔距F	中心距G	孔距H	孔径I	直径ΦJ	直径ΦK*深	本体高L
CZP-05B-004	200	200	25	180	100	150	100	25	PT1/8	Φ6.5	Φ11*7	8.5

### ● 4单元基础板尺寸

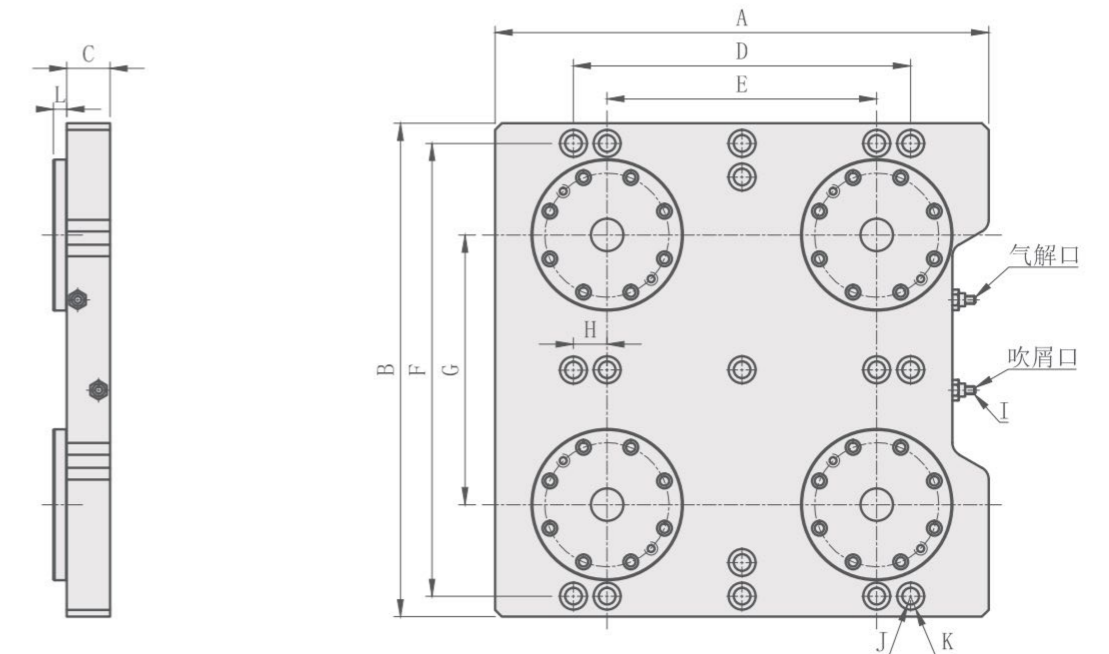

### 规格参数表 SPECIFICATION PARAMETER TABLE

型号	板长A	板宽B	板高C	孔距D	中心距E	孔距F	孔距G	孔距H	孔径I	直径ΦJ	直径ΦK*深	本体高L
CZP-10B-004	366	366	32	250	200	336	200	25	PT1/8	Φ12.5	Φ20*13	10
CZP-20B-004	398	398	38	250	200	364	200	25	PT1/4	Φ12.5	Φ20*13	15
CZP-40B-004	420	420	52	250	200	395	200	25	PT1/4	Φ12.5	Φ20*13	18

● 圆形4单元基础板尺寸

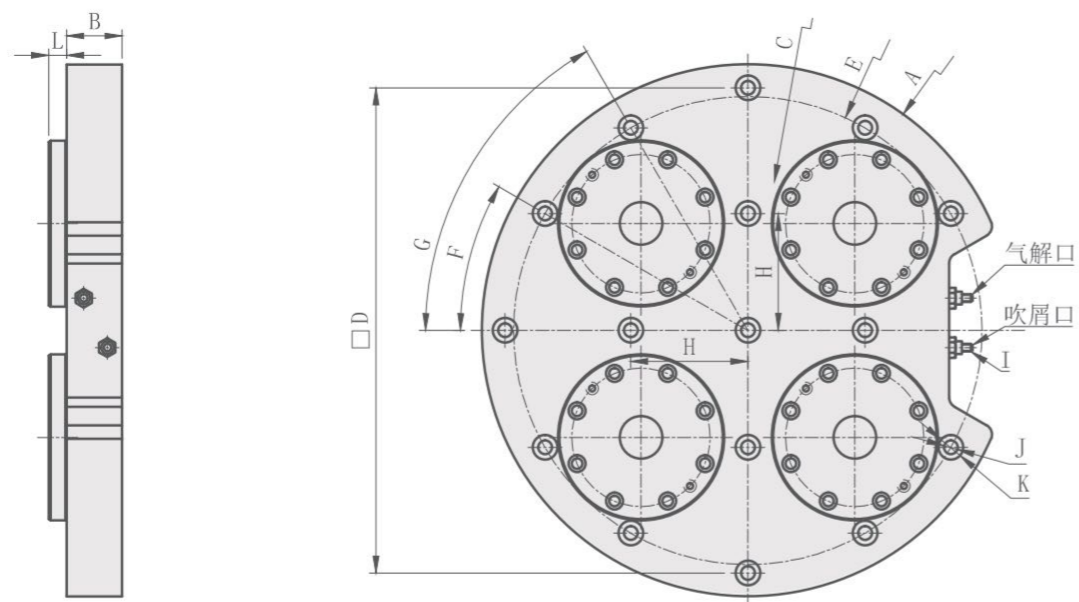

规格参数表 SPECIFICATION PARAMETER TABLE

Unit:mm

型号	板直径ΦA	板高B	参考圆C	孔距D	参考圆E	角度F	角度G	孔距H	孔径I	直径ΦJ	直径ΦK*深	本体高L
CZP-05B-Q04	Φ250	26	Φ142	228	Φ220	30°	60°	55	PT1/8	Φ6.5	Φ11*7	8.5

● 圆形4单元基础板尺寸

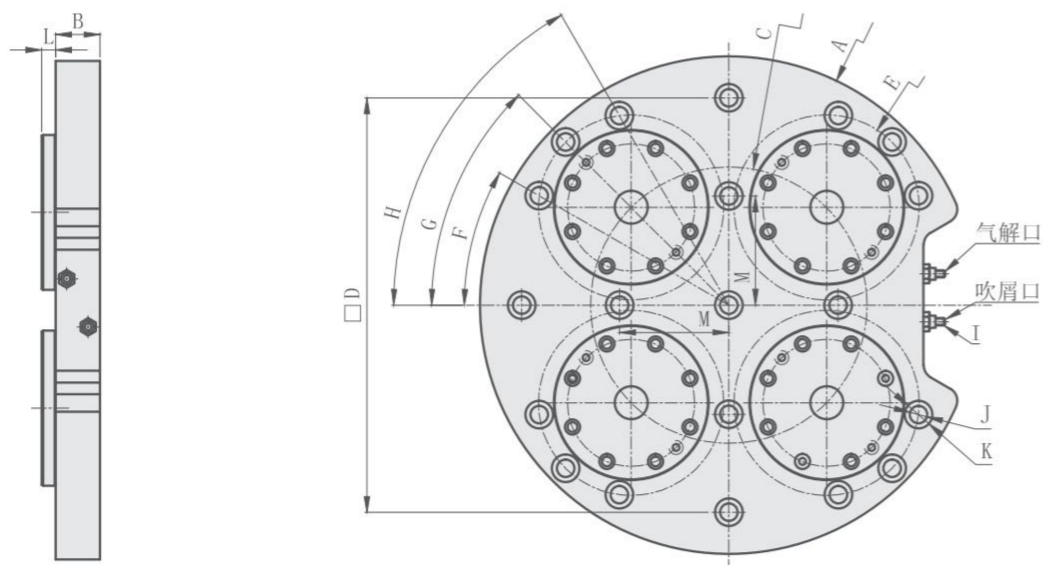

规格参数表 SPECIFICATION PARAMETER TABLE

Unit:mm

型号	板直径ΦA	板宽B	参考圆C	孔距D	参考圆E	角度F	角度G	角度H	孔径I	直径ΦJ	直径ΦK*深	本体高L	孔距M
CZP-10B-Q04	Φ360	32	Φ200	300	Φ134	30°	45°	60°	PT1/8	Φ12.5	Φ20*13	10	80
CZP-20B-Q04	Φ470	38	Φ260	400	Φ164	30°	45°	60°	PT1/4	Φ12.5	Φ20*13	15	100
CZP-40B-Q04	Φ520	52	Φ280	400	Φ195	30°	45°	60°	PT1/4	Φ12.5	Φ20*13	18	100

● 6单元基础板尺寸

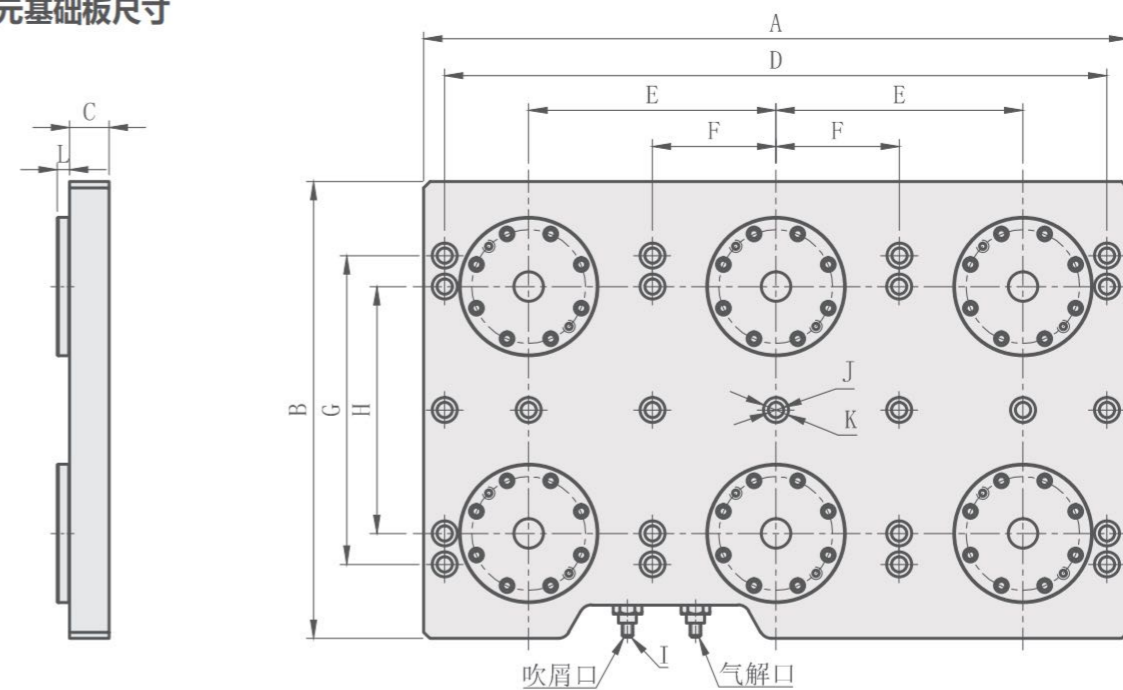

规格参数表 SPECIFICATION PARAMETER TABLE

Unit:mm

型号	板长A	板宽B	板高C	孔距D	中心距E	孔距F	孔距G	中心距H	孔径I	直径ΦJ	直径ΦK*深	本体高L
CZP-10B-006	570	370	32	536	200	100	250	200	PT1/8	Φ12.5	Φ20*13	10
CZP-20B-006	590	398	38	564	200	100	250	200	PT1/4	Φ12.5	Φ20*13	15
CZP-40B-006	625	398	52	595	200	100	250	200	PT1/4	Φ12.5	Φ20*13	18

● 8单元基础板尺寸

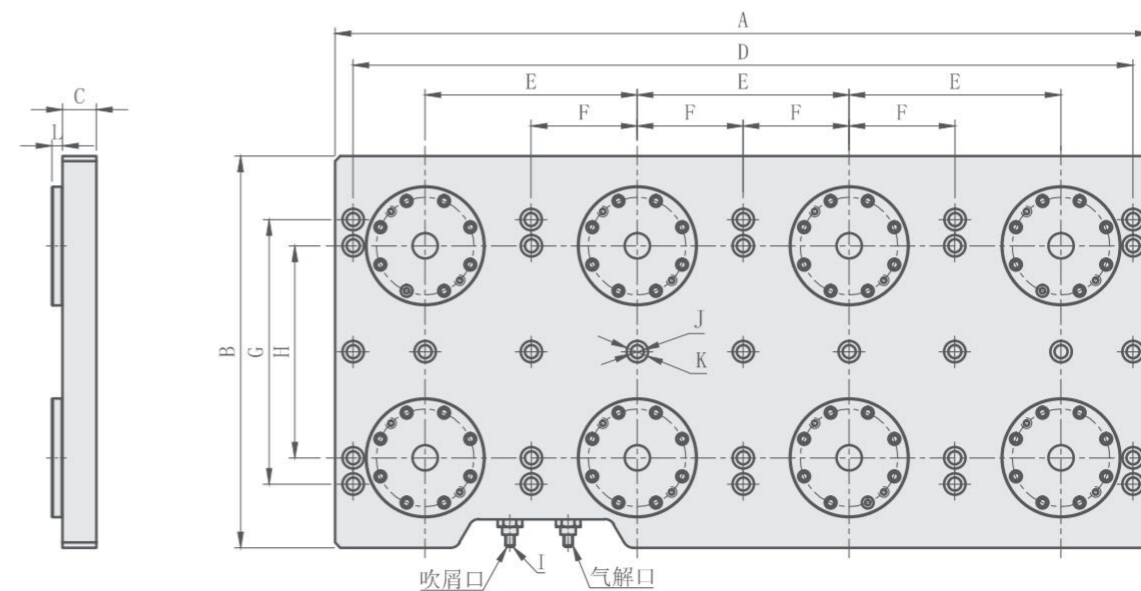

规格参数表 SPECIFICATION PARAMETER TABLE

Unit:mm

型号	板长A	板宽B	板高C	孔距D	中心距E	孔距F	孔距G	中心距H	孔径I	直径ΦJ	直径ΦK*深	本体高L
CZP-10B-008	770	370	32	736	200	100	250	200	PT1/8	Φ12.5	Φ20*13	10
CZP-20B-008	798	398	38	764	200	100	250	200	PT1/4	Φ12.5	Φ20*13	15
CZP-40B-008	838	398	52	800	200	100	250	200	PT1/4	Φ12.5	Φ20*13	18

- 1.定位销  
Positioning pin
- 2.定向销  
Directional pin
- 3.锁紧销  
Locking pin
- 4.保护销  
Protective pin

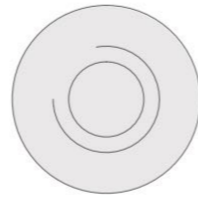
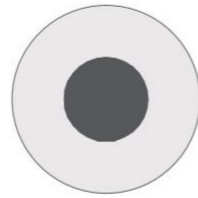
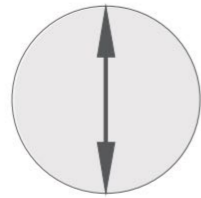
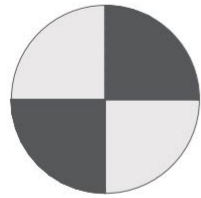

注:此保护销为提供空余单元使用。

● 两单元拉钉安装示意图:

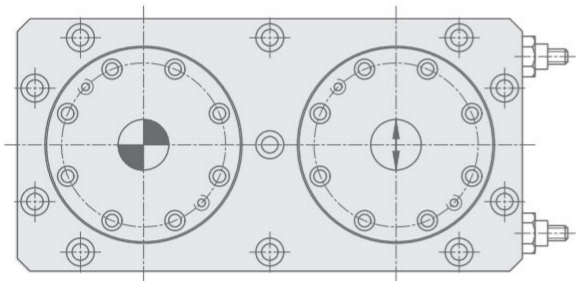

● 四单元拉钉安装示意图:

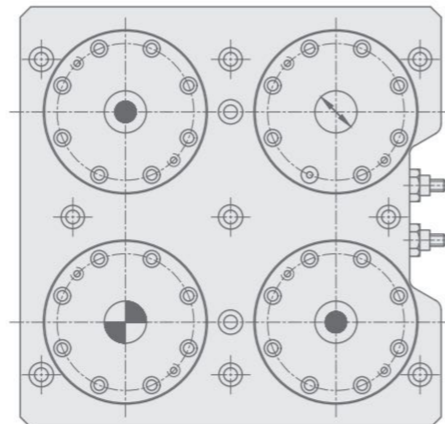

● 六单元拉钉安装示意图:

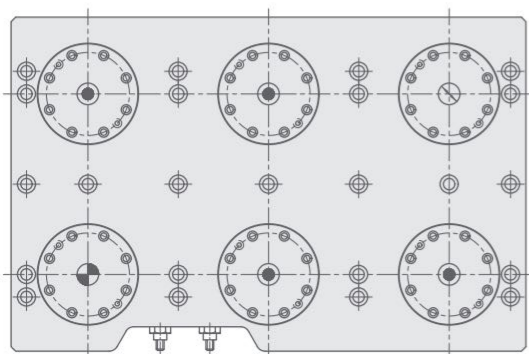

● 八单元拉钉安装示意图:

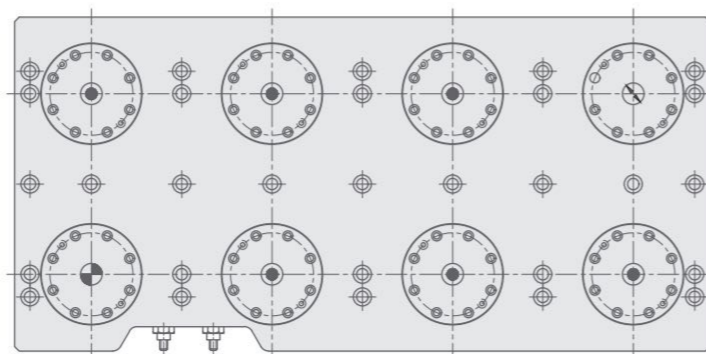

## Q&A零点定位器常见的问题和答案

### Q&A COMMON QUESTIONS AND ANSWERS ABOUT ZERO POINT SYLTEM

**问 什么是夹紧力和拉紧力?**

- 夹紧力:指的是锁紧销被拉入到零点定位器中被滚珠夹紧时所受到的力。
- 拉紧力:指的是紧固螺栓的最大允许拉力。

**What are clamping forces and tensioning forces?**

- Clamping force: the force that the locking pin receives when the ball clamps it after entering the zero positioning unit.
- Tension: The allowable tension of the locking bolt.

**问 零点定位器是如何操作使用的?**

- 第一步:将零点定位器安装于基础板上。
- 第二步:将所需的拉销分别安装在工件的反面或托盘反面。
- 第三步:将零点定位器接上气源后,打开气源,将零点定位器呈解锁状态。
- 第四步:将安装好拉销的工件或托盘对准零点定位器的孔槽,放置其内。
- 第五步:切断气源,将零点定位器呈锁紧状态,方可加工工件。

**How does the zero position system work?**

- (1) The zero positioner base plate is installed on the CNC machining center machine tool;
- (2) Install the positioning pin on the opposite side of the machining workpiece or the opposite side of the upper tray;
- (3) Connect the zero point positioner to the air source, turn on the air source, and unlock the zero point positioner;
- (4) Directly place the workpiece or upper tray in the zero positioning unit through the positioning pin;
- (5) After cutting off the air source, the locator will lock the positioning pin, reach the locking state, and start processing.

**问 零点定位器适用于什么环境?**

- 环境限制:Clamptek的零点定位器适合大部分加工环境,例如车削、铣削、磨削、注塑等等,若需要用于恶劣环境中,请与我司技术人员联系。
- 温度限制:正常工作温度不超过摄氏80°,如需超过,请与我司技术人员联系。

**Zero-Point Systems Applicable Environment?**

- Working Environmental Restrictions: Clamptek's zero-point systems is suitable for most processing environments, such as turning, milling, grinding, injection molding, etc.
- Temperature restrictions: The normal operating temperature does not exceed 80°C. If you need to use it in a harsh environment or high temperature, please contact our engineer in advance.

**问 使用不同的拉销,有什么优点?**

- 定位销:固定参考点的重复精度由定位销产生的。
- 定向销:提供旋转方向的自由约束,以确保定位精度。
- 锁紧销:不起到对中的作用,主要起夹紧作用。
- 保护销:保护空余未使用零点定位器使用。

**What are the advantages of using different pull pins?**

- Positioning pin: The repeated positioning accuracy of fixed reference points is mainly generated by positioning pins.
- Directional pin: It provides free constraints on the rotation direction to ensure positioning accuracy.
- Locking pin: The locking pin has no positioning function only locking function.
- Protective pin: To protect the unused zero point positioner.

**问 什么是重复精度?**

- 重复精度:指的是在工件上记录的参考点,在工件从夹具移开,再重新装夹后,同一工件上的这个参考点变动的公差范围,它影响同一批零件加工的一致性,是一个非常重要的精度指标。
- Clamptek 零点定位器的重复精度:<0.005mm。

**What is repeated positioning accuracy?**

- Repeated positioning accuracy: The tolerance range of the change in the position of the reference point on the same workpiece after the reference point of the workpiece is removed from the fixture and re-clamped, which affects the consistency of the processing of a number of parts, is a very important accuracy indicator.
- The repetitive positioning accuracy of Clamptek zero positioner is <0.005mm.

**问 什么是自动除屑功能?它是怎么工作的?**

- 自动除屑功能是指将压缩气体,从零点定位器底部导入产生气流,并把切屑、冷却液或其他杂质,从零点定位器的中央通道中吹出。

**What is the automatic chip removal function? How does it work?**

- The automatic chip removal function means that compressed air is sprayed from the bottom of the zero positioner. The air flow will blow chips, coolant or other impurities out of the center of the zero positioner.

**问 如果自己安装零点定位器,拉销之间的间距误差应该保持在多少以内?**

- 拉销之间的间距误差须保持在±0.005mm以内。

**If you install your own zero positioner, how much should the spacing error between the Latin?**

- The spacing error between the nails should be kept within +/-0.005mm.

# CVM

## 油压扩径定位销

# CVM HYDRAULIC EXPANSION LOCATING PIN



### 产品特性

重复定位精度CVM:±3μm  
定位销与工件孔之间的间隙为零

最大操作压力:70 kgf/cm<sup>2</sup>  
最小操作压力:25 kgf/cm<sup>2</sup>

### FEATURES

Locating Repeatability CVM:±3μm  
Zero clearance between locating pin and the workpiece hole.

Max.operating pressure:70 kgf/cm<sup>2</sup>  
Min.operating pressure:25 kgf/cm<sup>2</sup>

### 订购标示法 ORDERING INDICATION

示例: CVM 12 - D-S

CVM	系列 Series																																		
12	工件孔径 (标准孔径) Workpiece Hole Diameter (Standard)	08 : Φ8H8 mm 09 : Φ9H8 mm 10 : Φ10H8 mm 12 : Φ12H8 mm 13 : Φ13H8 mm 15 : Φ15H8 mm 16 : Φ16H8 mm 18 : Φ18H8 mm 20 : Φ20H8 mm																																	
D	功能分类 Functions	D : 锥销 (基准定位用) C : 菱形销 (1个方向定位用) D : Datum (for Reference Locating) C : Cut (for One Direction Locating)																																	
S	对应工件孔径 Applicable Workpiece Hole Diameter	<table border="1"> <thead> <tr> <th>型号 Model No.</th> <th>S:标准径 Standard Diameter</th> <th>A□□□准标准径 Substandard Diameter</th> </tr> </thead> <tbody> <tr> <td>CVM08</td> <td>8H8</td> <td>8.1H8 ~ 8.8H8</td> </tr> <tr> <td>CVM09</td> <td>9H8</td> <td>8.9H8 ~ 9.9H8</td> </tr> <tr> <td>CVM10</td> <td>10H8</td> <td>10.1H8 ~ 11.3H8</td> </tr> <tr> <td>CVM12</td> <td>12H8</td> <td>11.4H8 ~ 12.7H8</td> </tr> <tr> <td>CVM13</td> <td>13H8</td> <td>12.8H8 ~ 14.2H8</td> </tr> <tr> <td>CVM15</td> <td>15H8</td> <td>14.3H8 ~ 15.7H8</td> </tr> <tr> <td>CVM16</td> <td>16H8</td> <td>15.8H8 ~ 16.9H8</td> </tr> <tr> <td>CVM18</td> <td>18H8</td> <td>17.0H8 ~ 17.9H8</td> </tr> <tr> <td>CVM18</td> <td>18H8</td> <td>18.1H8 ~ 18.4H8</td> </tr> <tr> <td>CVM20</td> <td>20H8</td> <td>18.5H8 ~ 19.9H8</td> </tr> </tbody> </table>	型号 Model No.	S:标准径 Standard Diameter	A□□□准标准径 Substandard Diameter	CVM08	8H8	8.1H8 ~ 8.8H8	CVM09	9H8	8.9H8 ~ 9.9H8	CVM10	10H8	10.1H8 ~ 11.3H8	CVM12	12H8	11.4H8 ~ 12.7H8	CVM13	13H8	12.8H8 ~ 14.2H8	CVM15	15H8	14.3H8 ~ 15.7H8	CVM16	16H8	15.8H8 ~ 16.9H8	CVM18	18H8	17.0H8 ~ 17.9H8	CVM18	18H8	18.1H8 ~ 18.4H8	CVM20	20H8	18.5H8 ~ 19.9H8
型号 Model No.	S:标准径 Standard Diameter	A□□□准标准径 Substandard Diameter																																	
CVM08	8H8	8.1H8 ~ 8.8H8																																	
CVM09	9H8	8.9H8 ~ 9.9H8																																	
CVM10	10H8	10.1H8 ~ 11.3H8																																	
CVM12	12H8	11.4H8 ~ 12.7H8																																	
CVM13	13H8	12.8H8 ~ 14.2H8																																	
CVM15	15H8	14.3H8 ~ 15.7H8																																	
CVM16	16H8	15.8H8 ~ 16.9H8																																	
CVM18	18H8	17.0H8 ~ 17.9H8																																	
CVM18	18H8	18.1H8 ~ 18.4H8																																	
CVM20	20H8	18.5H8 ~ 19.9H8																																	

### 规格参数表 SPECIFICATION

型号 MODEL	工件孔径 Workpiece Hole Diameter		重复定位精度 Locating Repeatability	容许偏心量 (C:菱形销) Offset Tolerance (C:cut)	定位力*2 25MPa 5.0MPa 7.0MPa			容许剪切载荷*3 Allowable Thrust Load	定位侧油缸容量 (Lock side) Cylinder Capacity (Lock side)	释放侧油缸容量 (Release side) Cylinder Capacity (Release side)	最高使用压力 Max. Operating Pressure	最低使用压力 Min. Operating Pressure	使用温度 Operating Temperature	重量 Weight	使用流体 Usable Fluid
CVM08	8H8	8.1-8.8	0.003	±0.05	260	430	510	1.5	0.05	0.06	7.0	2.5	0~70	90	相当于ISO黏度等级的ISO-VG-32一般液压油 Recommended: ISO-VG-32 hydraulic oil equivalent to ISO viscosity grade
CVM09	9H8	8.9-9.9	0.003	±0.05	260	430	510	1.5	0.05	0.06	7.0	2.5	0~70	90	
CVM10	10H8	10.1-11.3	0.003	±0.10	260	430	510	2.0	0.05	0.06	7.0	2.5	0~70	95	
CVM12	12H8	11.4-12.7	0.003	±0.10	260	430	510	2.5	0.05	0.06	7.0	2.5	0~70	95	
CVM13	13H8	12.8-14.2	0.003	±0.10	260	430	510	2.5	0.05	0.06	7.0	2.5	0~70	95	
CVM15	15H8	14.3-15.7	0.003	±0.10	260	430	510	2.5	0.05	0.06	7.0	2.5	0~70	100	
CVM16	16H8	15.8-16.9	0.003	±0.15	290	470	550	3.0	0.11	0.15	7.0	2.5	0~70	115	
CVM18	18H8	17.0-18.4	0.003	±0.15	290	470	550	3.0	0.11	0.15	7.0	2.5	0~70	120	
CVM20	20H8	18.5-19.9	0.003	±0.15	290	470	550	3.5	0.11	0.15	7.0	2.5	0~70	125	

### 外形尺寸 EXTERNAL DIMENSIONS

※本图所示CVM-D的释放状态(油压供给时)

※This drawing shows the released state of CVM-C.  
(When supplying release hydraulic pressure)

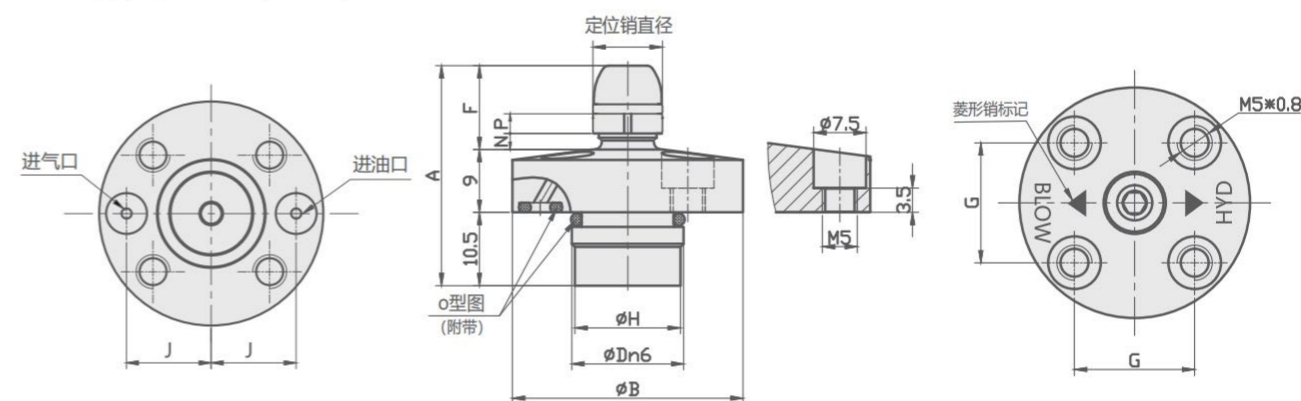

### 安装部位加工尺寸 MACHINING DIMENSIONS OF MOUNTING AREA

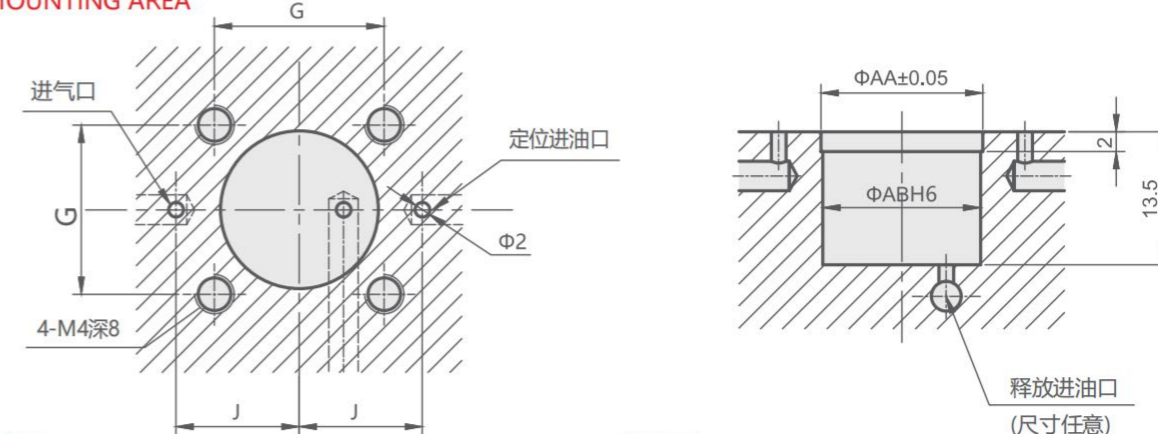

### 注意事项

- ※1.只有-C:菱形销上印有识别标记。◀▶是表示定位方向
- ※2.M5x0.8螺纹是在卸下定位销时使用的。
- ※3.法兰侧面刻印有供给口名称。(HYD:定位用供给口, BLOW:空气清洁用供给口)

### Notes

- ※ 1. The identification mark is only found on C: Cut. Refer to ◀▶ marking, locating direction.
- ※ 2. The M5 x 0.8 threads are used when removing the datum cylinder
- ※ 3. The port name is imprinted on the side.(HYD: Lock hydraulic port, BLOW: Air blow port)

工件(托盘)的加工尺寸  
WORKPIECE (PALLET) MACHINING DIMENSIONS

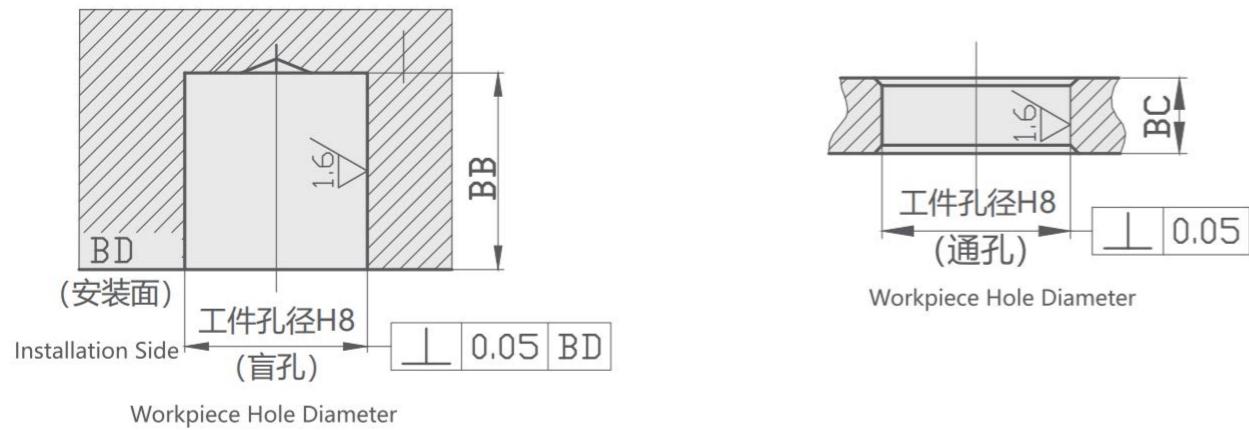

规格参数表 SPECIFICATIONS

型号 MODEL	工件孔径 Workpiece Hole Diameter		定位销孔径 Datum Diameter	(标准径) (Standard)	定位销径 Datum Diameter	(标准径) (Substandard)	全行程 Full Stroke mm	容许偏心量 (C: 菱形销) Offset Tolerance (C.cut) mm
	标准径 Standard Diameter mm	标准径* Substandard Diameter* mm	释放时(MAX) When Releasing (MAX) mm	全行程时(MIN) When Full Stroke(MIN) mm	释放时(MAX) When Releasing (MAX) mm	全行程时(MIN) When Full Stroke(MIN) mm		
CVM08	8H8	8.1 ~ 8.8	7.94	8.05	工件孔径 Workpiece Hole Diameter - 0.06	工件孔径 Workpiece Hole Diameter + 0.05	0.6	±0.05
CVM09	9H8	8.9 ~ 9.9	8.94	9.05			0.6	±0.05
CVM10	10H8	10.1 ~ 11.3	9.94	10.05	工件孔径 Workpiece Hole Diameter - 0.08	工件孔径 Workpiece Hole Diameter + 0.05	0.6	±0.10
CVM12	12H8	11.4 ~ 12.7	11.92	12.05			0.7	±0.10
CVM13	13H8	12.8 ~ 14.2	12.92	13.05	工件孔径 Workpiece Hole Diameter - 0.11	工件孔径 Workpiece Hole Diameter + 0.08	0.7	±0.10
CVM15	15H8	14.3 ~ 15.7	14.92	15.05			0.7	±0.10
CVM16	16H8	15.8 ~ 16.9	15.89	16.08	工件孔径 Workpiece Hole Diameter - 0.11	工件孔径 Workpiece Hole Diameter + 0.08	1.0	±0.15
CVM18	18H8	17.0 ~ 18.4	17.89	18.08			1.0	±0.15
CVM20	20H8	18.5 ~ 19.9	19.89	20.08			1.0	±0.15

Unit:mm

MODEL	A	B	D	F	G	H	J	N	P	R定位销径标准径时 Standard Datum Diameter	O形密封圈S O-ring S	O形密封圈T O-ring T	Y	AA	AB	AC	BB	BC
CVM08	31.5	33	16n6	12	17.2	15.7	12.5	2.5	2.6	4.8	AS568 -014( 90°)	AS568- 005(70°)	6.7	16.1	16H6 <sup>-0.011</sup> <sub>0</sub>	16	12.5	5.5
CVM09	31.5	33	16n6	12	17.2	15.7	12.5	2.5	2.6	5.8			Workpiece Hole Diameter -3.2	6.7		16.1	16	12.5
CVM10	31.5	33	16n6	12	17.2	15.7	12.5	2.3	2.8	6.8	AS568 -014( 90°)	AS568- 005(70°)	6.7	16.1	16H6 <sup>-0.011</sup> <sub>0</sub>	16	12.5	5.5
CVM12	32	33	16n6	12.5	17.2	15.7	12.5	2.1	3.2	8.7			Workpiece Hole Diameter -3.3	6.5		16.1	16	13
CVM13	32	33	16n6	12.5	17.2	15.7	12.5	2.1	3.2	9.7	AS568 -014( 90°)	AS568- 005(70°)	6.5	16.1	16H6 <sup>-0.011</sup> <sub>0</sub>	16	13	5.5
CVM15	32	33	16n6	12.5	17.2	15.7	12.5	2.1	3.2	11.7			Workpiece Hole Diameter -4.7	6.5		16.1	16	13
CVM16	36	37	19n6	16.5	19.6	18.7	14.5	2.7	4.5	11.3	AS568 -014( 90°)	AS568- 005(70°)	6.5	19.1	16H6 <sup>-0.011</sup> <sub>0</sub>	19	17	7.5
CVM18	36	37	19n6	16.5	19.6	18.7	14.5	2.7	4.5	13.3			Workpiece Hole Diameter -4.7	6.5		19.1	19	17
CVM20	36	37	19n6	16.5	19.6	18.7	14.5	2.7	4.5	15.3			6.5	19.1		19	17	7.5

注意事项 NOTE

设计方面的注意事项CVM通用Notes for Design CVM common

1.确认规格

●使用前请确认各产品的规格。  
CVM 型产品采用油压定位，油压释放结构。

2.定位销的设置

●定位销是用于定位的，并不具有夹紧功能。请另行设置夹紧缸。

3.建议将空气清洁回路的直径设定在Φ6mm 以上。

4.关于定位销的安装方向(相位)

●-C-菱形销(CVM)是以-D:基准销(CVM)为基准进行旋转方向定位的。所以安装时必须注意-C(菱形销)的相位  
CVM时

安装-C(菱形销)时，请将-C(菱形销)的定位方向标记垂直于-D(基准销)。(-C(菱形销)本体的法兰上面印有定位方向标记:▲。)

5.关于Z轴方向的基准面

●本型号产品无着座面(Z轴方向基准面)。

请另行设置Z轴方向定位的着座面。  
并在定位销的法兰上面与工件(托盘)之间设置间隙。  
(推荐间隙:0.5~1mm)

6.关于定位销的高度调整

●扩径定位销的高度比着座面的高度低时，可以在定位销下面设置垫块调整定位销的高度。

7.工件(托盘)垂直姿势(挂壁式)使用时

- 装卸工件(托盘)时请防止工件(托盘)浮起或倾斜现象。如果在浮起的状态下进行定位，就有可能导致装置的损坏。
- 释放时，工件(托盘)有可能坠落时，请在外部设置预夹装置。
- 工件(托盘)垂直姿势(挂壁式)使用会导致定位销内部滑动部位的偏磨。请定期确认定位精度，如果超出容许范围，请立即更换装置。

8.关于工件(托盘)的重量

●请将工件(托盘)水平姿势(平置)使用时的工件(托盘)重量设定为

$$\text{工件重量} \leq \frac{1 \text{ 台定位销的定位力}}{\text{工件着座面的摩擦系数}}$$

●请将工件(托盘)垂直姿势(挂壁式)使用的工件(托盘)的重量设定为

$$\text{工件重量} \leq \frac{1 \text{ 台定位销的定位力}}{1}$$

●如果在上述姿势之外使用时，请另行询问。

1.Check Specifications

●Please use each product according to the specifications.  
CVM locates and releases with hydraulic pressure.

2.Setting Up the Clamps

●The datum cylinder is a positioning cylinder and has no clamping mechanism.A clamp must be provided separately.

3.It is recommended to use the air flow path overΦ6mm.

4.Clamp Mounting Direction (Phase)

●The reference position (origin) is determined by CVM-D (Datum: for Reference Locating). CVM-C (Cut: for One Direction Locating) locates in one direction (Y-axis), so phasing is necessary

In the case of CVM

When you mount it, make sure the CVM-C (cut) cut mark is perpendicular to CVM-D (datum). (There is a cut mark (▲) on top of the Bange on the CVM-C unit that shows the locating direction.)

5.Reference Surface towards Z-axis

●Datum cylinder has no seat face (Z axis datum face). Please prepare for the seat separately for proper Z axis direction positioning. Make sure there is clearance between the top of the flange on the datum cylinder and the workpiece (pallet).(Recommended clearance: 0.5~1mm)

6.Adjusting Height of Datum Cylinder

●For applications where the seat face is high and the height of datum cylinder is not enough, the height of datum cylinder is adjustable using a spacer block under the datum cylinder.

7.When the workpiece (pallet) is the vertical position.

●When the workpiece (pallet) is being set, ensure that it is in proper proximity and square to the clamps.

As the workpiece (pallet) may fall down during releasing, it is recommended to set up the latching mechanism to prevent it from falling down.

●When the workpiece (pallet) is used a vertical position (hanging on the wall), the internal moving parts tend to wear out. confirm the positioning precision in a regular manner. In case the allowed range is exceeded, change the machine.

8.Workpiece (Pallet) Weight

●The Workpiece (Pallet) Weight Calculation - Horizontal Attitude:

$$\text{工件重量} \leq \frac{1 \text{ 台定位销的定位力}}{\text{工件着座面的摩擦系数}}$$

●请将工件(托盘)垂直姿势(挂壁式)使用的工件(托盘)的重量设定为

$$\text{工件重量} \leq \frac{1 \text{ 台定位销的定位力}}{1}$$

●如果在上述姿势之外使用时，请另行询问。

### 9.关于Z轴方向的倾斜

- 如果工件(托盘)在倾斜状态下进行装卸, 定位销的扩径部位与工件孔产生别紧力而造成定位销及工件(托盘)的损坏。因此在装卸工件(托盘)时, 对于定位销的倾斜度应在 4/100~5/100(约2~3°)以下。
- 工件(托盘)装卸时, 在工件(托盘)倾斜的状态下装卸(特别是卸下)时, 会导致定位销的损坏。请设置导向销(粗导销)。

### 9.Incline in the Z-axis direction.

- If workpiece (pallet) is loaded/unloaded on tilted condition, expanded part of datum cylinder and workpiece hole can become stuck and damage the cylinder and workpiece is possible. Workpiece (pallet) should be loaded and unloaded with less than 4/100~5/100 (approx. 2 ~ 3°) of tilt between workpiece and datum cylinder plane
- If necessary provide guide pins to keep the pallet level during loading and unloading. Please prepare guide pin (rough guide) etc.

### 10.关于工件孔周边的壁厚

- 如果工件孔周围存在薄壁部分, 定位动作会造成工件孔变形, 并导致定位力不能满足规定值。使用前请进行夹紧试验, 将供给油压调整至最适合的油压状态。

### 10.Thickness around the Workpiece Hole

- In case that the material thickness is thin around locating hole, expansion force may deform the hole. It may cause unsatisfied locating accuracy. Please do trial testing and adjust to proper pneumatic pressure.

### 安装施工方面注意事项 NOTE

#### ● 设计方面的注意事项CVM

##### 1)关于CVM定位销安装孔的间距精度

- 请将CVM定位销安装孔的间距精度保证在±0.02mm以内。容许偏心量(-C:菱形销) ≥ 定位销间距精度 + 工件孔间距精度(±0.02)。请参考下示JIS B0613中心距离容许差[2级]。

#### Notes for to CVM

##### 1) Distance Accuracy of CVM

- Distance accuracy of the CVM's mounting hole should be within ±0.02mm. The distance accuracy of each workpiece hole (Pallet Hole) should be within the allowable tolerance. Please refer to below table under JIS B 0613 Class 2.

中心距离的分类 CENTER DISTANCE CLASSIFICATION		中心距离的容许差 CENTER DISTANCE ACCURACY
大于 Greater than	小于 or less	2级 class2
50	80	±0.023
80	120	±0.027
120	180	±0.032
180	250	±0.036
250	315	±0.041
315	400	±0.045
400	500	±0.049
500	630	±0.055
630	800	±0.063
800	1000	±0.070

##### 1)确认液压油

##### 2)机器的安装

- 请使用附带的安装螺栓(强度等级12.9), 并按照下表给出的紧固力矩进行安装。为了避免设备倾斜, 请均等地紧固螺栓。

##### 1) Check the Usable Fluid

##### 2) Mounting Cylinder

- Use all bolts with hex holes (grade 12.9) and tighten the body with a torque wrench as shown in the table below. Tighten them evenly to prevent twisting or jamming.

型号 Model No.	安装螺栓名称 Thread Size	紧固力矩 Tightening Torque (Nm)
CVM	M4×0.7	3.2

##### 3)拆卸

- 请利用顶起用螺纹, 在保持设备平行的状态下进行拆卸
- 为了防止顶起用螺栓损坏安装用螺纹的端面, 请使用平行销对螺纹的端面采取保护措施。

##### 4)扩径定位销的油口位置

CVM:HYD定位用供油口、BLOW:喷气清洁用供气口

定位油压是由定位用供油口实施供给。

5) 请将喷气清洁回路外径设定在Φ6(内径Φ4)以上。

- 为确保喷气清洁的效果, 推荐使用外径Φ6(内径Φ4)以上的气管。

##### 3) Removing Cylinder

- Remove with torque wrench in a parallel fashion when detaching.
- Protect the screw parts with parallel pins as shared in the graph below in order for the bolts used for jack not to damage the surface of mounting screws.

##### 4) Port Location of Datum Cylinder

CVM: HYD : Hydraulic Lock Port. BLOW : Air Blow Port  
Hydraulic pressure is supposed to be supplied from lock port

- To do an effective air blow, it is recommended to use air piping with outside diameter Φ6 (inside diameter Φ4) or larger.

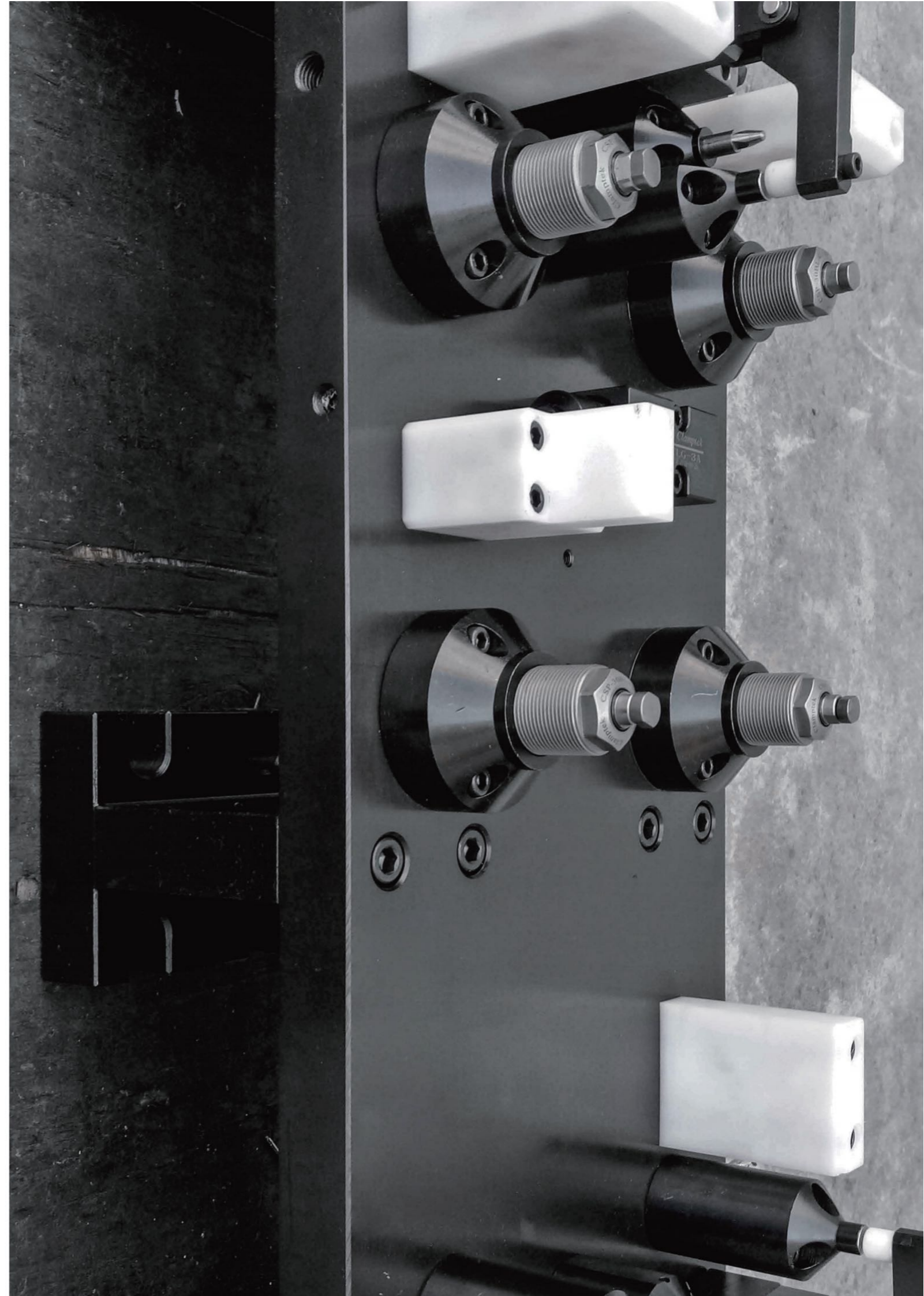

# CTC

## 外螺纹小型油压单动缸

## CTC HYDRAULIC THREAD CYLINDER



### 产品特性

外螺纹小型单动缸采用进口油封及零件,确保品质,使用时漏油量少,高压夹持中保持长时间不漏油。外螺纹式小型单动缸体积小,使用于夹具上,能在小的空间内排列使用。

此型式油压缸使用于顶出场合,弹簧退回,无法使用于拉式场合上。安装时尽可能垂直于工作面,倾斜勿超过10°。缸体底部需置放一只锁紧防漏垫圈。

最大操作压力: 250 kgf/cm<sup>2</sup>  
最小操作压力: 20 kgf/cm<sup>2</sup>  
作动方式: 单动式

### FEATURES

The Thread-body single acting hydraulic cylinder use imported oil seal and accessories to guarantee the quality. No oil leakage while clamping in high pressure for a long time. The volume of the thread body single acting hydraulic cylinder is small. It can be utilized in a small space in the fixture. This hydraulic cylinder is used to extend out and when spring returns, but it can't be used for pulling back. The angle degree between the cylinder and workpiece could not be larger than 10° while installing. The bottom of the cylinder barrel needs a leakage-proof gasket.

Max. operating pressure: 250 kgf/cm<sup>2</sup>  
Min. operating pressure: 20 kgf/cm<sup>2</sup>  
Single acting

剖面图 Sectional view

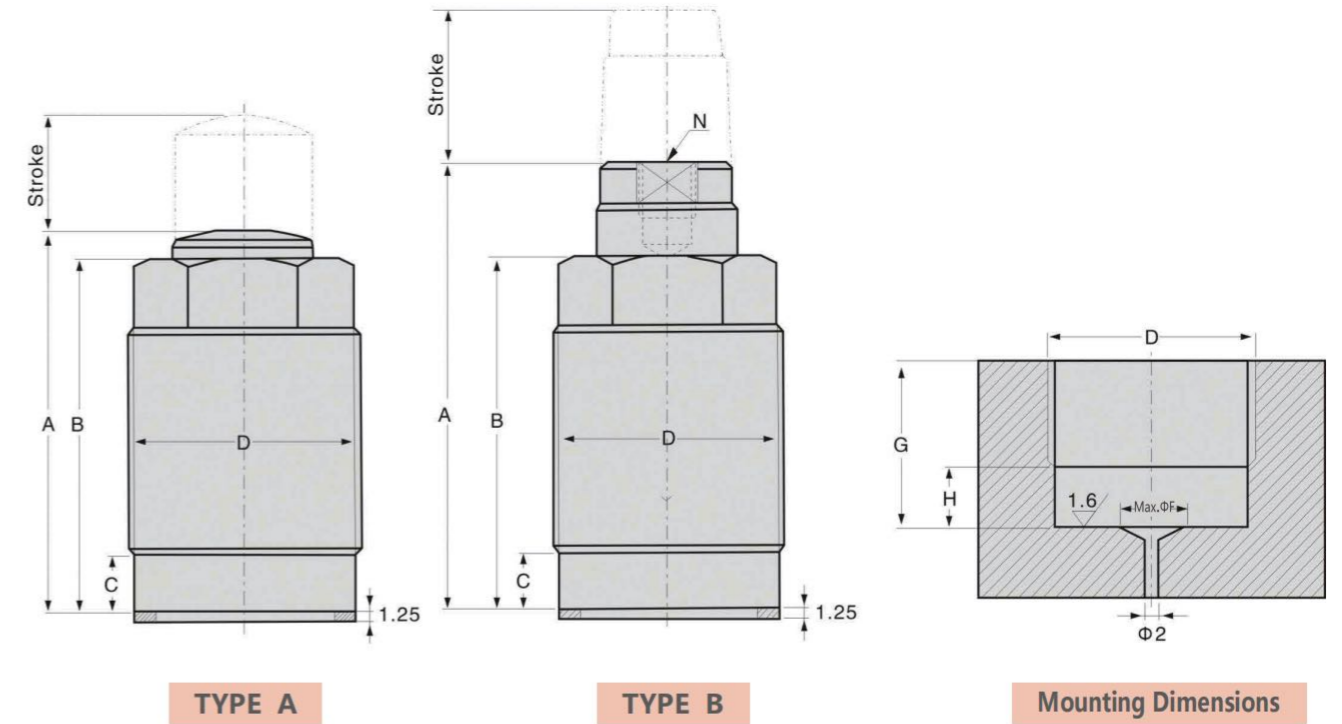
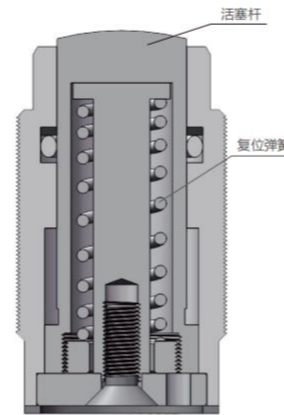

### 规格参数表 SPECIFICATIONS

型号	理论夹持力(250 kgf/cm <sup>2</sup> )	总行程	推出容积	推出受压面积	弹簧阻抗	使用流体
MODEL	CLAMPING FORCE AT 250kgf/cm <sup>2</sup> (kgf)	TOTAL STROKE(mm)	CYLINDER CAPACITY CLAMP(cm <sup>3</sup> )	EFFECTIVE AREA CLAMP(cm <sup>2</sup> )	SPRING FORCE(kgf)	USABLE FLUID
CTC-12A	247.5	10	2.14	1.13	6~13	相当于ISO黏度等级的ISO-VG-32一般液压油 Recommended: ISO-VG-32 hydraulic oil equivalent to ISO viscosity grade
CTC-16A	475	12	4.24	2.00	6~16	
CTC-20A	765	15	7.29	3.14	9~16	
CTC-25A	1210	16	11.85	4.90	16~33	
CTC-12B	247.5	10	2.14	1.13	6~13	
CTC-16B	475	12	4.24	2.00	6~16	
CTC-20B	765	15	7.29	3.14	9~16	
CTC-25B	1210	16	11.85	4.90	16~33	

### 订购标示法 ORDERING INDICATION

#### 示例: CTC-16A

CTC	系列 Series	CTC
16	活塞杆径 Piston diameter	Φ12, Φ16, Φ20, Φ25
A	类型 type	分为A、B两种 It can be divided into A and B

Unit:mm

MODEL	A	B	C	D	F	G	H	N	ST
CTC-12A	38	36	7	M22×1.5	12	16	6	-	10
CTC-16A	46.5	44.5	8	M26×1.5	16	20	7	-	12
CTC-20A	57.5	51	8	M30×1.5	20	24	7	-	15
CTC-25A	58.5	55	11	M38×1.5	25	28	10	-	16
CTC-12B	45	36	7	M22×1.5	12	16	6	M6×1.0	10
CTC-16B	52	44.5	8	M26×1.5	16	20	7	M6×1.0	12
CTC-20B	64.5	51	8	M30×1.5	20	24	7	M8×1.25	15
CTC-25B	67.5	55	11	M38×1.5	25	28	10	M8×1.25	16

注: 理论夹持力=受压面积×工作压力-弹簧阻抗  
弹簧阻抗指其最大理论值

# CTC-K

## 外螺纹小型油压单动缸

### CTC-K HYDRAULIC THREAD CYLINDER



#### 产品特性

外螺纹小型单动缸采用进口油封及零件, 确保品质, 使用时漏油量极少, 高压夹持中保持长时间不漏油。外螺纹式小型单动缸体积小, 使用于夹具上, 能在小空间内排列使用。

此型式油压缸使用于顶出场合, 弹簧退回, 无法使用于拉式场合上。安装时尽可能垂直于工作面, 倾斜勿超过10°。缸体底部需置放一只锁紧防漏垫圈。

最大操作压力: 250 kgf/cm<sup>2</sup>  
最小操作压力: 20 kgf/cm<sup>2</sup>  
作动方式: 单动式

#### FEATURES

The Thread-body single acting hydraulic cylinder use imported oil seal and accessories to guarantee the quality. No oil leakage while clamping in high pressure for a long time. The volume of the thread body single acting hydraulic cylinder is small. It can be utilized in a small space in the fixture. This hydraulic cylinder is used to extend out, and when spring returns, but it can't be used for pulling back.

The angle degree between the cylinder and workpiece could not be larger than 10° while installing. The bottom of the cylinder barrel needs a leakage-proof gasket.

Max.operating pressure: 250 kgf/cm<sup>2</sup>  
Min.operating pressure: 20 kgf/cm<sup>2</sup>  
Single acting

#### 剖面图 Sectional view

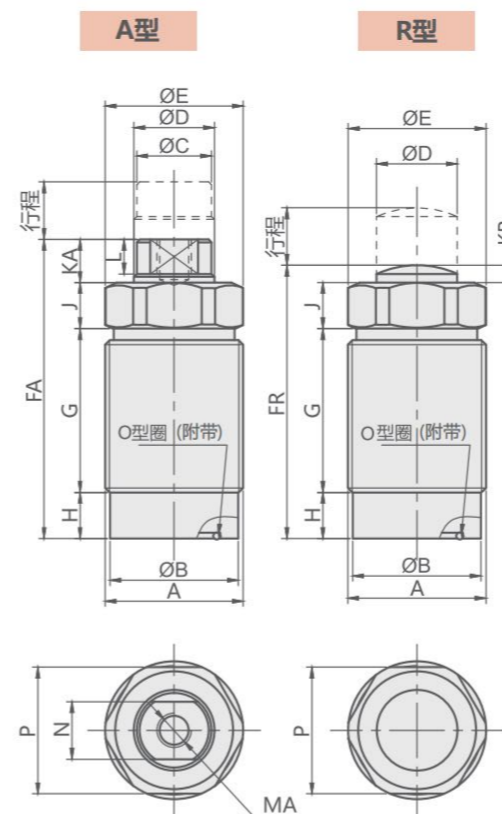
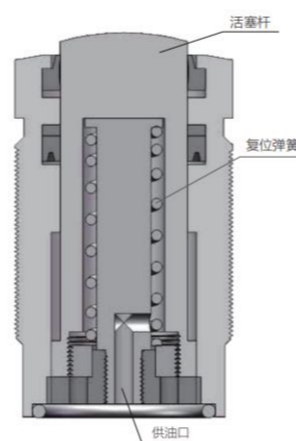

#### 安装部位加工尺寸

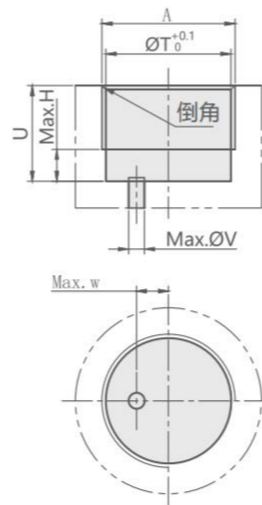

#### 外形尺寸及安装部位加工尺寸表

External dimensions and machine dimensions for mounting

Unit:mm

MODEL	CTC-K016	CTC-K022	CTC-K024	CTC-K030	CTC-K036	CTC-K045	CTC-K055	
A	M16×1.5	M22×1.5	M24×1.5	M30×1.5	M36×1.5	M45×1.5	M55×2	
B	14.3	20.3	22.3	28.3	34.3	43.3	52.6	
C	7.5	11.2	13	17	19	28	34.5	
D	8	12	14	18	22.4	30	35.5	
E	15.5	21.2	24.5	30	35.5	45	55	
FA行程代码	S	35	35	39.5	43.5	51	64	
	M	41	43	47	52.5	64	79.5	
	L	50	56	63.5	72	85	94.5	
G行程代码	S	18.5	13	17.5	18	23.5	27	
	M	24.5	21	25	27	36.5	36	
	L	33.5	34	41.5	46.5	57.5	58.5	
H	6	8	8	9	10	12	12	
J	5	7	7	8	8	12	12	
KA	5.5	7	7	8.5	9.5	12	13	
L	4	5.5	5.5	7	8	10	11	
MA	M5×8	M6×7	M6×7	M8×10	M8×10	M10×11	M12×12	
N	7	10	10	14	17	24	30	
P	14	19	22	27	32	41	50	
T	14.5	20.5	22.5	28.5	34.5	43.5	53	
U行程代码	S	12<U<23	14<U<20	14<U<24	15<U<26	16<U<32	18<U<34	20<U<38
	M	12<U<29	14<U<28	14<U<32	15<U<35	16<U<45	18<U<47	30<U<53
	L	12<U<38	14<U<2H	14<U<48	15<U<54	16<U<66	18<U<69	20<U<76
V	3	3	3	6	6	8	8	
W	0	3.5	5.5	6	8	10	13	
倒角	C1	C1	C1	C1	C1	C1	C1.5	
O形圈	P9	AS569-015	AS568-017	AS568-020	AS568-120	P31.5	P39	

#### 外形尺寸及安装部位加工尺寸表

External dimensions and machine dimensions for mounting

Unit:mm

MODEL	CTC-K016	CTC-K022	CTC-K024	CTC-K030	CTC-K036	CTC-K045	CTC-K055	
A	M16×1.5	M22×1.5	M24×1.5	M30×1.5	M36×1.5	M45×1.5	M55×2	
B	14.3	20.3	22.3	28.3	34.3	43.3	52.6	
D	8	12	14	18	22.4	30	35.5	
E	15.5	21.2	24.5	30	35.5	45	55	
FR行程代码	S	31	30.5	35	38	45	51	
	M	37	38.5	42.5	47	58	64	
	L	46	51.5	59	66.5	79	86.5	
G行程代码	S	18.5	13	17.5	18	23.5	27	
	M	24.5	21	25	27	36.5	36	
	L	33.5	34	41.5	46.5	57.5	58.5	
H	6	8	8	9	10	12	12	
J	5	7	7	8	8	12	12	
KR	1.5	2.5	2.5	3	3.5	4	5	
P	14	19	22	27	32	41	50	
T	14.5	20.5	22.5	28.5	34.5	43.5	53	
U行程代码	S	12<U<23	14<U<20	14<U<24	15<U<26	16<U<32	18<U<34	20<U<38
	M	12<U<29	14<U<28	14<U<32	15<U<35	16<U<45	18<U<47	30<U<53
	L	12<U<38	14<U<41	14<U<48	15<U<54	16<U<66	18<U<69	20<U<76
V	3	3	3	6	6	6	8	
W	0	3.5	5.5	6	8	10	13	
倒角	C	C1	C1	C1	C1	C1	C1.5	
O形圈	P9	AS568-015	AS568-017	AS568-020	AS568-120	P31.5	P39	

#### 规格参数表 SPECIFICATIONS

型号	理论夹持力 (250 kgf/cm <sup>2</sup> )	总行程	推出容积	推出受压面积	使用温度范围	使用流体
MODEL	CLAMPING FORCE AT 250kgf/cm <sup>2</sup> (kgf)	TOTAL STROKE(mm)	CYLINDER CAPACITY CLAMP(cm <sup>3</sup> )	EFFPISTON AREA CLAMP(cm <sup>2</sup> )	RANGE OF TEMPERATURE(°C)	USABLE FLUID
CTC-K016	120	S:6/M:10/L:16	0.3/0.5/0.8	0.5	0~+70°C	相当于ISO黏度等级的ISO-VG-32一般液压油 Recommended: ISO-VG-32 hydraulic oil equivalent to ISO viscosity grade
CTC-K022	280	S:6/M:10/L:16	0.9/1.1/1.8	1.1	0~+70°C	
CTC-K024	388	S:8/M:12/L:20	1.2/1.8/3.1	1.5	0~+70°C	
CTC-K030	643	S:8/M:12/L:20	2/3.1/5.5	2.5	0~+70°C	
CTC-K036	990	S:10/M:16/L:25	3.9/6.3/9.9	3.9	0~+70°C	
CTC-K045	1775	S:10/M:16/L:25	7.1/11.3/17.7	7.1	0~+70°C	
CTC-K055	2479	S:12/M:20/L:32	11.9/19.8/31.7	9.9	0~+70°C	

#### 订购标示法 ORDERING INDICATION

#### 示例: CTC-K024AL

CTC-K	系列 Series	CTC-K
024	016/022/024/030/036/045/055	
A	类型 TYPE	分为A、R两种 It can be divided into A and R
L	行程 STROKE	(具体行程见尺寸表) Please refer to the dimension table for the more details

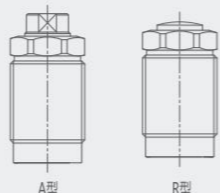

# CTC-P

## 外螺纹小型油压单动缸

### CTC-P HYDRAULIC THREAD CYLINDER



#### 产品特性

外螺纹小型单动缸采用进口油封及零件，确保品质，使用时漏油量极少，高压夹持中保持长时间不漏油。外螺纹式小型单动缸体积小，适用于夹具上，能在小空间内排列使用。

此型式油压缸使用于顶出场合，弹簧退回，无法使用于拉式场合上。安装时尽可能垂直于工作面，倾斜勿超过10°。缸体底部需置放一只锁紧防漏垫圈。

最大操作压力：350 kgf/cm<sup>2</sup>  
最小操作压力：20 kgf/cm<sup>2</sup>  
作动方式：单动式

#### FEATURES

The Thread-body single acting hydraulic cylinder use imported oil seal and accessories to guarantee the quality. No oil leakage while clamping in high pressure for a long time. The volume of the thread body single acting hydraulic cylinder is small. It can be utilized in a small space in the fixture. This hydraulic cylinder is used to extend out, and when spring returns, but it can't be used for pulling back. The angle degree between the cylinder and workpiece could not be larger than 10° while installing. The bottom of the cylinder barrel needs a leakage-proof gasket.

Max.operating pressure: 350 kgf/cm<sup>2</sup>  
Min.operating pressure: 20 kgf/cm<sup>2</sup>  
Single acting

#### 剖面图 Sectional view

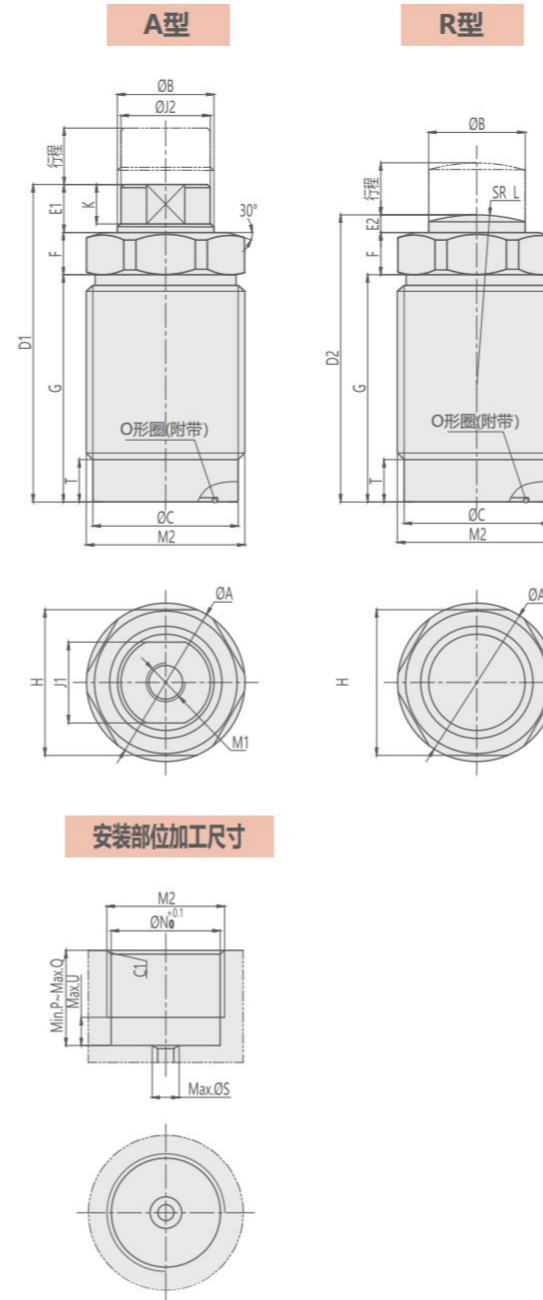
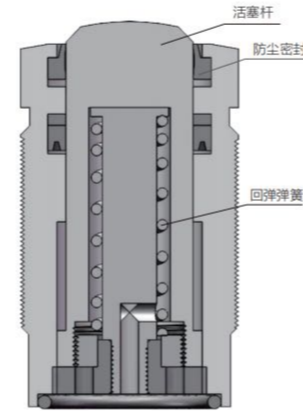

外形尺寸及安装部位加工尺寸表  
External dimensions and machine dimensions for mounting

Unit:mm

MODEL	CTC-P016	CTC-P022	CTC-P025	CTC-P030	CTC-P036	CTC-P048	CTC-P055
A	15.5	24	26	33	40	50	55
B	8	12	14	18	22.4	32	35.5
C	14.3	20.3	23.3	28.3	34.3	46	52.6
D1 行程	5	31	31	36	40.5	44.5	-
	10	41	41	47	51.5	54.5	67.5
	12	-	-	-	-	-	67
	15	50	51.5	58	62.5	66.5	80.5
	20	-	-	68	72.5	-	92
	25	-	-	-	-	87.5	-
D2 行程	5	27	27	31	34	36.5	-
	10	37	37	42	45	46.5	57
	12	-	-	-	-	-	56
	15	46	47.5	53	56	58.5	70
	20	-	-	63	66	-	81.5
	25	-	-	-	-	79.5	-
E1	5.5	7	8.5	10	12	16	17.5
	1.5	3	3.5	3.5	4	5.5	6.5
F	6	8	9	10.5	12.5	14	15
M1	M5x0.8深8	M6x1深6	M6x1深11	M8x1.25深13	M8x1.25深13	M12x1.75深18	M12x1.75深18
M2	M16x1.5	M22x1.5	M25x1.5	M30x1.5	M36x1.5	M48x1.5	M55x2.0
G 行程	5	19.5	16	18.5	20	20	-
	10	29.5	26	29.5	31	30	37.5
	12	-	-	-	-	-	34.5
	15	38.5	36.5	40.5	42	42	50.5
H	20	-	-	50.5	52	-	62
	25	-	-	-	-	63	-
	32	-	-	-	-	-	88.5
	72	-	-	-	-	-	72
J1	7	10	12	14	19	27	30
J2	7.5	11	13	17	21.4	30	32.5
K	4.5	5.5	6.5	7.5	9.5	12.5	13.5
L	16	20	25	32	40	50	60
N	14.5	20.5	23.5	28.5	34.5	46.5	53
P	12	13	14	15	17	20	24
	5	19	15.5	18	19.5	19.5	-
	10	29	25.5	29	30.5	29.5	37
	-	-	-	-	-	-	-
Q 行程	12	-	-	-	-	-	35.5
	15	38	36	40	41.5	41.5	50
	20	-	-	50	51.5	-	61.5
	25	-	-	-	-	62.5	-
S	5	8	10	14	19	26	34
	7	7	7	7	7	7	10
T	6	6	6	6	6	6	9
	9	9	9	9	9	9	9
U	6	6	6	6	6	6	9
O形圈	AS568-012	AS568-015	AS568-016	AS568-019	AS568-022	AS568-126	AS568-129

#### 订购标示法 ORDERING INDICATION

示例: CTC-P022A-10

CTC-P	系列 Series	CTC-P
022	016/022/025/030/0361048/055	
A	类型 TYPE	分为A型/R型两种 It can be divided into A and R
10	行程 STROKE	(具体行程见尺寸表) Please refer to the dimension table for the more details

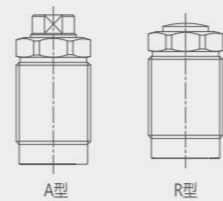

#### 规格参数表 SPECIFICATIONS

型号	理论夹持力 (350 kgf/cm <sup>2</sup> )	总行程	推出容积	推出受压面积	使用温度范围	使用流体
MODEL NO.	CLAMPING FORCE AT 350kgf/cm <sup>2</sup> (kgf)	TOTAL STROKE(mm)	CYLINDER CAPACITY CLAMP(cm <sup>3</sup> )	EFFPISTON AREA CLAMP(cm <sup>2</sup> )	RANGE OF TEMPERATURE(°C)	USABLE FLUID
CTC-P016	170	5/10/15	0.3/0.5/0.8	0.5	0~+70°C	相当于ISO黏度等级的ISO-VG-32一般液压油 Recommended: ISO-VG-32 hydraulic oil equivalent to ISO viscosity grade
CTC-P022	397	5/10/15	0.6/1.1/1.7	1.13	0~+70°C	
CTC-P025	540	5/10/15/20	0.8/1.5/2.3/3.1	1.54	0~+70°C	
CTC-P030	897	5/10/15/20	1.3/2.5/3.8/5.1	2.55	0~+70°C	
CTC-P036	1398	5/10/15/25	2.0/3.9/5.9/9.9	3.94	0~+70°C	
CTC-P048	2846	10/15/20/32	8.0/12.0/16.0/20.1	8.04	0~+70°C	
CTC-P055	3500	12/20/32	11.9/19.8/31.7	9.90	0~+70°C	

# CTC-PD

## 外螺纹小型油压单动拉缸

## CTC-PD HYDRAULIC THREAD PULL CYLINDER



### 产品特性

外螺纹小型单动缸采用进口油封及零件，确保品质，使用时漏油量极少，高压夹持中保持长时间不漏油。外螺纹式小型单动缸体积小，适用于夹具上，能在小空间内排列使用。

此型式油缸使用于拉式场合，弹簧顶出无法用于顶出场合。安装时尽可能垂直于工作面，倾斜勿超过10°。

缸体底部需置放一只锁紧防漏垫圈。

最大操作压力：350 kgf/cm<sup>2</sup>

最小操作压力：20 kgf/cm<sup>2</sup>

作动方式：单动式

### FEATURES

The Thread-body single acting hydraulic cylinder use imported oil seal and accessories to guarantee the quality. No oil leakage while clamping in high pressure for a long time. The volume of the thread-body single acting hydraulic cylinder is small. It can be utilized in a small space in the fixture. This hydraulic cylinder is used to extend out, and when spring returns, but it can't be used for pulling back.

The angle degree between the cylinder and workpiece could not be larger than 10° while installing. The bottom of the cylinder barrel needs a leakage proof gasket.

Max. operating pressure: 350 kgf/cm<sup>2</sup>

Min. operating pressure: 20 kgf/cm<sup>2</sup>

Single acting

### 剖面图 Sectional view

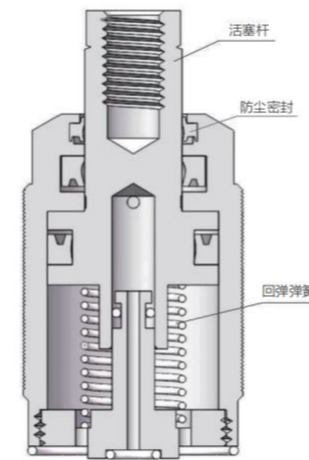

### 安装部位加工尺寸

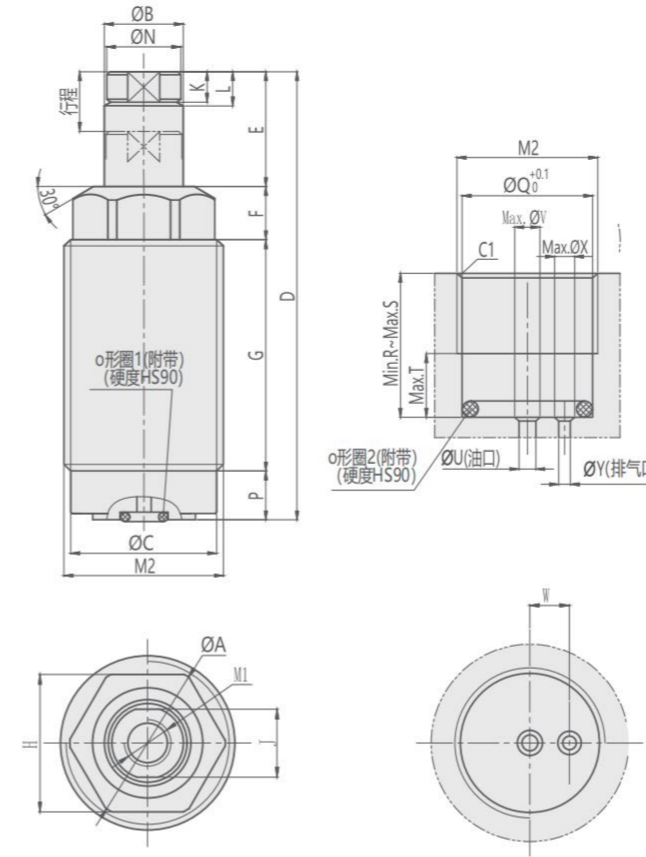

### 外形尺寸及安装部位加工尺寸表

External dimensions and machine dimensions for mounting Unit:mm

MODEL	CTC-PD022	CTC-PD025	CTC-PD030	CTC-PD036	CTC-PD048	CTC-PD058
A	19	21.5	27	33	45	55
B	10	10	12	16	20	25
C	20.3	23.3	28.3	34.3	46.3	56.3
D 行程	5	51	51	-	-	-
	10	65	65	69	73	88
	20	-	-	96	101	109
E 行程	5	10	10	-	-	-
	10	15	15	16	17	20.5
	20	-	-	26	27	30.5
F	7.5	8	9.5	11.5	13.5	16.5
G 行程	5	27	26.5	-	-	-
	10	36	35.5	35.5	35.5	38
	20	-	-	52.5	53.5	54.5
H	17	19	24	30	41	50
J	8	8	10	14	17	22
K	4.5	4.5	5.5	6.5	8.5	10
L	5	5	6	7	9	10.5
M1	M6X1深11	M6X1深11	M8X1.25深18	M10X1.5深20	M12X1.75深22	M16X2深27
M2	M22X1.5	M25X1.5	M30X1.5	M36X1.5	M48X1.5	M58X1.5
N	9.5	9.5	11.5	15.5	19.5	24.5
P	6.5	6.5	8	9	12	13
Q	20.5	23.5	28.5	34.5	46.5	56.5
R	13	14	15	17	20	20
S 行程	5	32.5	32	-	-	-
	10	41.5	41	42.5	43.5	50
	20	-	-	59.5	61.5	68
T	5.5	5.5	7	8	11	12
U	3	3	3	4	6	6
V	5	5	5	5	7	7
W	7	7.5	9.5	12	15	18
X	4	4	4	4	4	4
Y	3	3	3	3	3	3
○形圈1	P6	P6	P6	P6	P8	P8
○形圈2	AS568-017	AS568-019	AS568-022	AS568-026	AS568-031	AS568-034

### 订购标示法 ORDERING INDICATION

#### 示例: CTC-PD022-10

CTC-PD	系列 Series	CTC-PD
022	022/025/030/036/048/058	
10	行程 STROKE	(具体行程见尺寸表) Please refer to the dimension table for the more details



### 规格参数表 SPECIFICATIONS

型号	理论夹持力 (350 kgf/cm <sup>2</sup> )	油缸内径	总行程	拉入容积	拉入受压面积	使用温度范围	使用流体
MODEL	CLAMPING FORCE AT 350kgf/cm <sup>2</sup> (kgf)	HYDRAULIC CYLINDER INSIDE DIAMETER(mm)	TOTAL STROKE(mm)	OIL CAPACITY CLAMP(cm <sup>3</sup> )	EFF.PISTON AREA CLAMP(cm <sup>2</sup> )	RANGE OF TEMPERATURE(°C)	USABLE FLUID
CTC-PD022	296	16	5/10	0.5/0.9	0.84	0~+70°C	相当于ISO黏度等级的ISO-VG-32一般液压油 Recommended: ISO-VG-32 hydraulic oil equivalent to ISO viscosity grade
CTC-PD025	489	18	5/10	0.7/1.4	1.37	0~+70°C	
CTC-PD030	806	22	10/20	2.3/4.6	2.29	0~+70°C	
CTC-PD036	1326	28	10/20	3.8/7.5	3.76	0~+70°C	
CTC-PD048	2265	36	10/20	6.4/12.8	6.40	0~+70°C	
CTC-PD058	3918	46	10/20	11.1/22.2	11.07	0~+70°C	

# CLG

## 油压顺序阀 (日式规格)

### CLG HYDRAULIC SEQUENCE VALVE (JAPAN SPECIFICATION)



#### 注意事项

1次侧供油量过多有时会导致不能准确的进行顺序动作。请在1次侧油孔前面安装内置有单向阀的流量调节阀，或者在油压源上进行流量控制。

#### NOTE

If the flow volume of the incoming pressure side is too much, there is a possibility that the proper sequential procedures would not work. Please use a flow control valve to adjust flow volume from the pressure source.

#### 订购标示法 ORDERING INDICATION

示例: CLG-3A(5.0MPa)

CLG	系列 Series	CLG
3	顺序动作压力调整范围 Sequential action pressure adjustment range	3: 1.0~6.0 MPa 6: 5.0~18.0MPa
A	A油路板型式	A Manifold type
5.0MPa	设定压力(顺序动作压力的设定值) Set pressure(Set valve for sequence operating pressure)	1使用压力与设定压力的压差应设定在1MPa以上。 2.多台顺序阀并联于回路中使用, 相互间设定压力的压差应在1MPa以上。 1.The pressure difference between the working pressure and the set pressure should be set above 1MPa. 2.When multiple sequence valves are used in the circuit, the pressure difference between the set pressures should be set above 1MPa.

#### 规格参数表 SPECIFICATIONS

型号	顺序动作压力调整范围	使用压力范围	调节螺钉压力变化值 (MPa/每圈)	开启压力	使用温度	使用流体
MODEL	SEQUENTIAL ACTION PRESSURE ADJUSTMENT RANGE(MPa)	OPERATING PRESSURE RANGE(MPa)	ADJUSTING SCREW TURN RATIO(MPa/REV)	CRACKING PRESSURE (MPa)	OPERATING TEMPERATURE(°C)	USABLE FLUID
CLG-3A	1.0~6.0	2.0~35.0	1.0	0.01	0~70°C	相当于ISO粘度等级的ISO-VG-32一般液压油 Recommended: ISO-VG-32 hydraulic oil equivalent to ISO viscosity grade
CLG-6A	5.0~18.0	6.0~35.0	2.8	0.01	0~70°C	

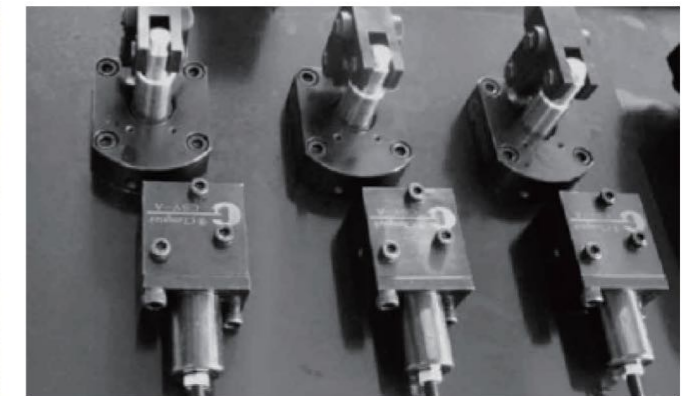
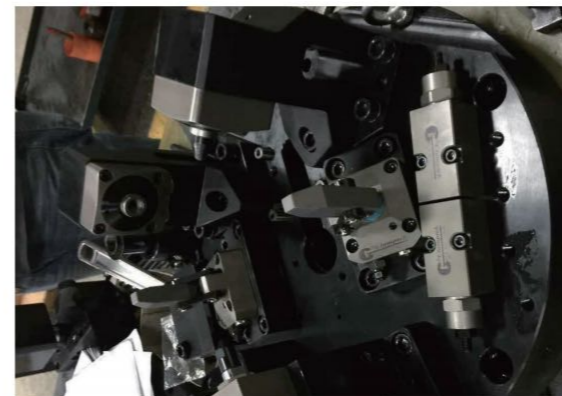
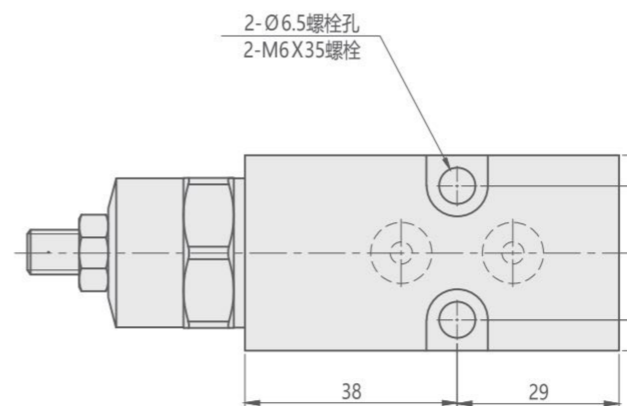
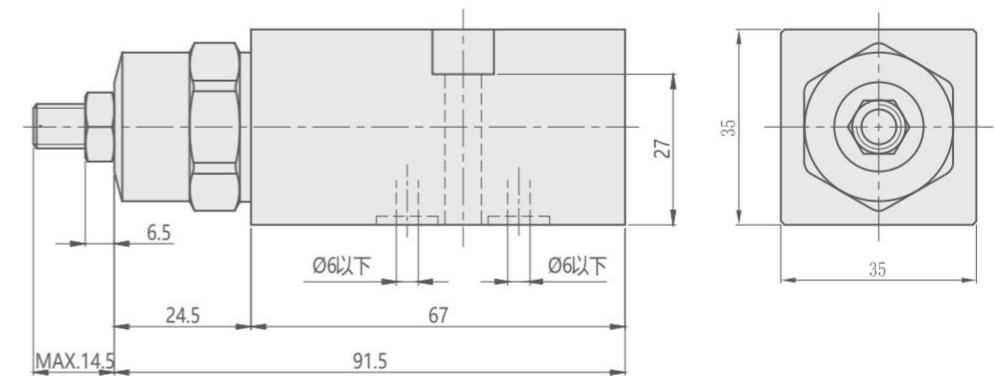
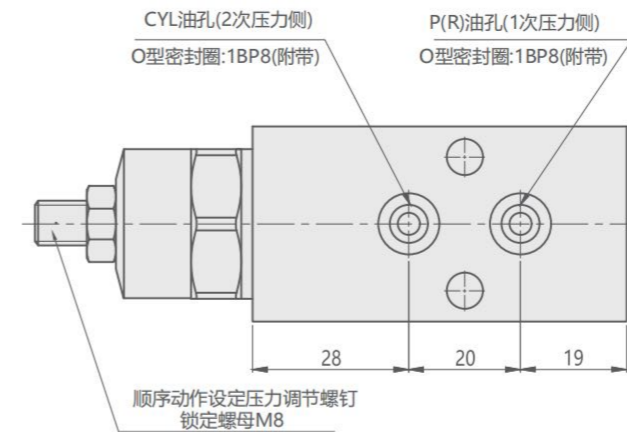

# SV-AT1

## 时间顺序阀

## SV-AT1 TIME SEQUENCE VALVE



### 产品特性

以时间阀与流量阀为基础，结合了时间阀与流量阀的特点，减少了使用数量与安装空间，适用于复杂环境的安装。缸径 $\Phi 20$ ，启动压力为2MPa，最高工作压力7MPa。

时间范围:1S-10S。

时间范围会因被调整油缸的缸径大小、行程及油缸压力的变化而有所差别。

### FEATURES

Based on the time of valve and the flow valve, combining with the characteristics of the valve and discharge valve to reduce the use quantity and installation space, more use in the installation of a complex environment; Cylinder diameter  $\Phi 20$ , start-up pressure 2 MPa, the highest working pressure 7 MPa.

Time range: 1 s to 10 s.

Time range will be adjust to the size of cylinder bore, stroke and the change of cylinder pressure is different.

### 注意事项

将密封螺母松开，调节时间顺序阀至所需时间，右旋调节杆时间变长，左旋调节杆时间变短；

调整好时间后，将密封螺母锁紧。

温馨提示：请在回油时调整时间阀。

使用流体：相当于ISO黏度等级的ISO-VG-32一般液压油。

### NOTE

When the sealing nut was loosening, please adjust the time sequence valve to the required time, and turn the adjusting lever time longer less time for left-turning adjusting lever.

After adjusting the time, lock the sealing nut tight.

Please adjust the time valve when returning oil.

Usable fluid: Recommended: ISO-VG-32 hydraulic oil equivalent to ISO viscosity grade

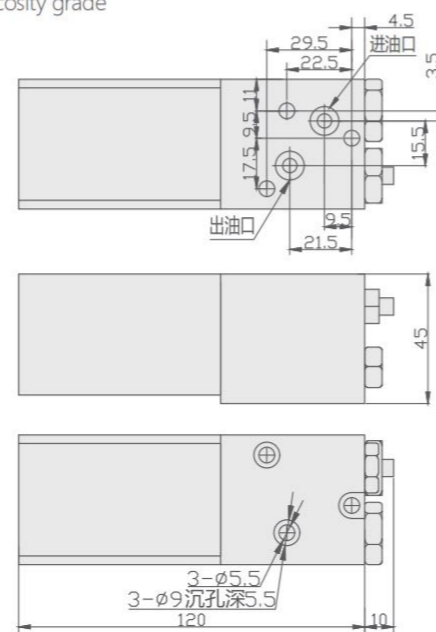
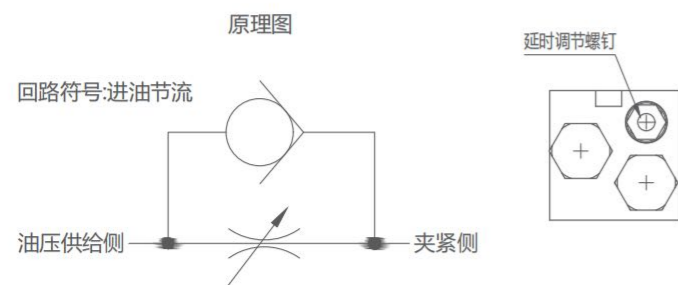

# CZL

速度控制阀(低压用)

## CZL SPEED CONTROL VALVE (LOW PRESSURE)

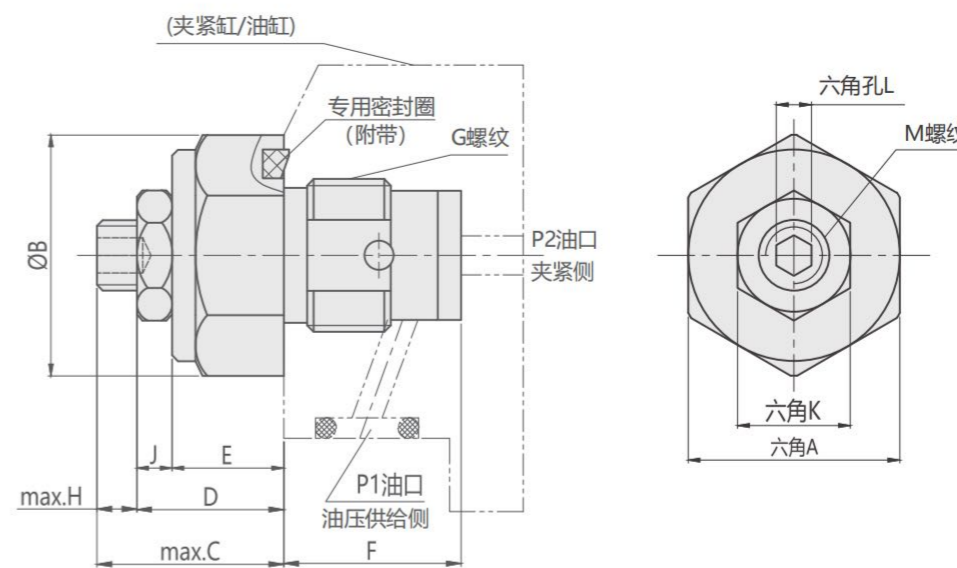

### 注意事项

1. 控制侧完全开启时的最小流道面积与下表的最大流道面积相等。
2. 必须按本体推荐紧固力矩安装速度控制阀。速度控制阀端面为金属密封结构，紧固力矩不足将无法进行流量调整。
3. 不可将曾经使用过的速度控制阀再用于其它油缸上。否则可能会因油缸的G螺纹底面深度差异而导致金属密封不严密，从而无法进行流量调整。

### NOTE

1. Minimum passage area when fully opened is the same as the maximum passage area in the table below.
2. It must be mounted with recommended torque. Because of the structure of the metal seal, if mounting torque is insufficient the flow control valve may not be able to adjust the flow rate.
3. Don't use used speed control valve(CZL) to other damp. Flow control will not be made because the bottom depth difference of G thread makes metal seal insufficient.

### 订购标示法 ORDERING INDICATION

示例: CZL-10B

CZL	系列 Series	CZL		
10	G螺纹尺寸 G thread size	10: 螺纹尺寸 G1/8 20: 螺纹尺寸 G1/4 30: 螺纹尺寸 G3/8	Thread part G1/8 thread Thread part G1/4 thread Thread part G3/8 thread	螺纹尺寸 Thread part
B	控制方式 Control method	A 进油节流 Meter-in B 回油节流 Meter-out	<div style="display: flex; justify-content: space-around;"> <div style="text-align: center;"> <p>A</p> <p>回路符号: 进油节流 Circuit symbols: Meter-in</p> </div> <div style="text-align: center;"> <p>B</p> <p>回路符号: 回油节流 Circuit symbols: Meter-out</p> </div> </div>	

### 规格参数表 SPECIFICATIONS

型号	最高使用压力	耐压	控制方式	G螺纹尺寸	开启压力	最大流道面积	使用温度	本体推荐紧固力矩(N.m)	使用流体
MODEL	MAX. OPERATING PRESSURE(MPa)	WITHSTANDING PRESSURE(MPa)	CONTROL METHOD	G THREAD SIZE	CRACKING PRESSURE (MPa)	MAX. PASSAGE AREA(mm <sup>2</sup> )	OPERATING TEMPERATURE(°C)	RECOMMEND TIGHTENING FOR MAIN BODY(N.m)	USABLE FLUID
CZL-10A	7	10.5	进油节流Meter-in	G1/8	0.04	2.6	0~70°C	10	相当于ISO黏度等级的ISO-VG-32一般液压油 Recommended: ISO-VG-32 hydraulic oil equivalent to ISO viscosity grade
CZL-20A	7	10.5	进油节流Meter-in	G1/4	0.04	5.0	0~70°C	25	
CZL-30A	7	10.5	进油节流Meter-in	G3/8	0.04	11.6	0~70°C	35	
CZL-10B	7	10.5	回油节流Meter-out	G1/8	0.12	2.6	0~70°C	10	
CZL-20B	7	10.5	回油节流Meter-out	G1/4	0.12	5.0	0~70°C	25	
CZL-30B	7	10.5	回油节流Meter-out	G3/8	0.12	10.2	0~70°C	35	

### 安装孔加工图

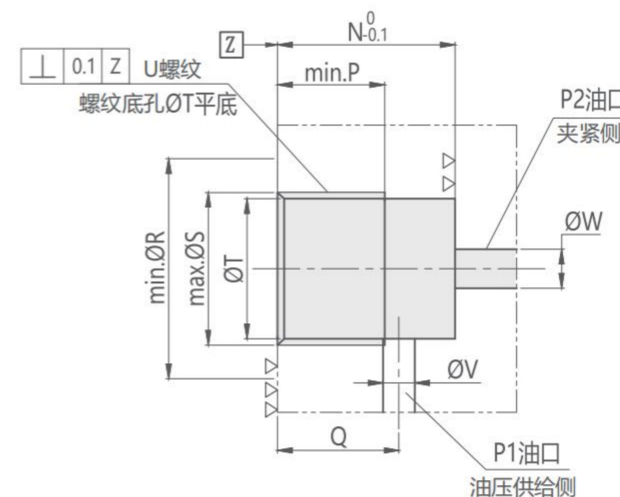

### 注意事项

1. ∇∇∇部将成为密封面，注意切勿受损。
2. ∇∇部将成为CZL端面的金属密封面，注意切勿受损。(去毛刺时注意)。
3. 加工孔公差部位切勿残留削屑、毛刺等异物。
4. 使用时请按图所示，将P1油口设定为油压供给侧，将P2油口设定为夹紧侧。
5. 如安装市场上销售的G螺纹规格的堵头和接头时，请将尺寸表内的[※1]设定为12.5。

### NOTE

1. As the ∇∇∇ area is sealing part, pay attention not to damage it.
2. As the ∇∇ area is the metal sealing part at the CZL side, pay attention not to damage it. (Notes for deburring).
3. Pay attention to have no cutting chips and burring at the tolerance part of the machining hole.
4. As shown in the drawing, P1-port is used as hydraulic supply and P2-port as the clamping supply.
5. If using a common plug and fitting with G thread specification are considered to be mounted, "※1" in the table should be 12.5.

Unit:mm

Model	A	B	C	D	E	F	G	H	J	K	L	M	N	P	Q	R	S	T	U	V	W
CZL-10	14	15.5	15	12	8.5	11.6	G1/8	3	3.5	10	3	M6x0.75	11.5	8.5	9	16	10	8.7	G1/8	2~3	2.5~5
CZL-20	18	20	16	13	9.5	15.1	G1/4	3	3.5	10	3	M6x0.75	15	11※1	11.5	20.5	13.5	11.5	G1/4	3~4	3.5~7
CZL-30	22	24	19	16	11	17.6	G3/8	3	5	13	4	M8x0.75	17.5	13	13	24.5	17	15	G3/8	4~5	4.5~9

# CZT

速度控制阀(高压用)

## CZT SPEED CONTROL VALVE(HIGH PRESSURE)

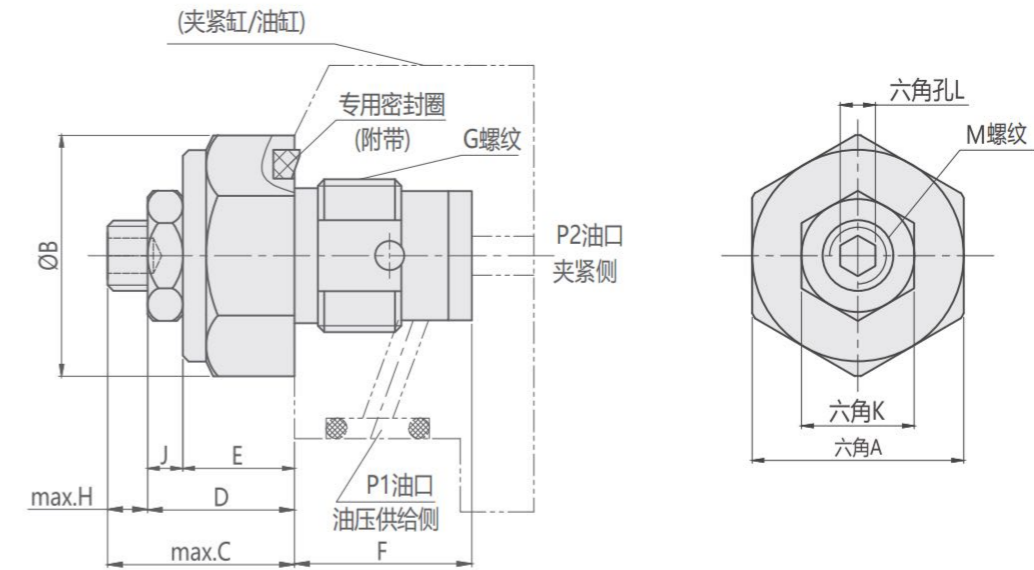

### 注意事项

- 1.控制侧完全开放时的最小流道面积与上表的最大流道面积相等。
- 2.必须按本体推荐紧固力矩安装速度控制阀。速度控制阀端面为金属密封结构, 紧固力矩不足将无法进行流量调整。
- 3.不可将曾经使用过的速度控制阀再用于其它油缸上。否则可能会因油缸的G螺纹底面深度差异而导致金属密封不严,从而无法进行流量调整。

### NOTE

1. Minimum passage area when fully opened is the same as the maximum passage area in the table above.
2. It must be mounted with recommended torque. Because of the structure of the metal seal, if mounting torque is insufficient, the flow control valve may not be able to adjust the flow rate.
3. Don't use used speed control valve(CZT) to other clamps. Flow control will not be made because the bottom depth difference of G thread makes metal sea insufficient.

### 订购标示法 ORDERING INDICATION

示例: CZT-10A

CZT	系列 Series	CZT
10	G螺纹尺寸 G thread size	10: 螺纹尺寸G1/8 20: 螺纹尺寸G1/4 Thread part G1/8 thread Thread part G1/4 thread
A	控制方式 Control method	A进油节流 Meter-in 回路符号: 进油节流 Circuit symbols: Meter-in

### 规格参数表 SPECIFICATIONS

型号	最高使用压力	耐压	控制方式	G螺纹尺寸	开启压力	最大流道面积	使用温度	本体推荐紧固力矩(N.m)	使用流体
Model	MAX. OPERATING PRESSURE(MPa)	WITHSTANDING PRESSURE(MPa)	CONTROL METHOD	G THREAD SIZE	CRACKING PRESSURE (MPa)	MAX. PASSAGE AREA(mm²)	OPERATING TEMPERATURE(°C)	RECOMMEND TIGHTENING FOR MAIN BODY(N.m)	USABLE FLUID
CZT-10A	35	40	进油节流Meter-in	G1/8	0.04	2.6	0~70°C	10	相当于ISO黏度等级的ISO-VG-32一般液压油
CZT-20A	35	40	进油节流Meter-in	G1/4	0.04	5.0	0~70°C	25	Recommended: ISO-VG-32 hydraulic oil equivalent to ISO viscosity grade

### 安装孔加工图

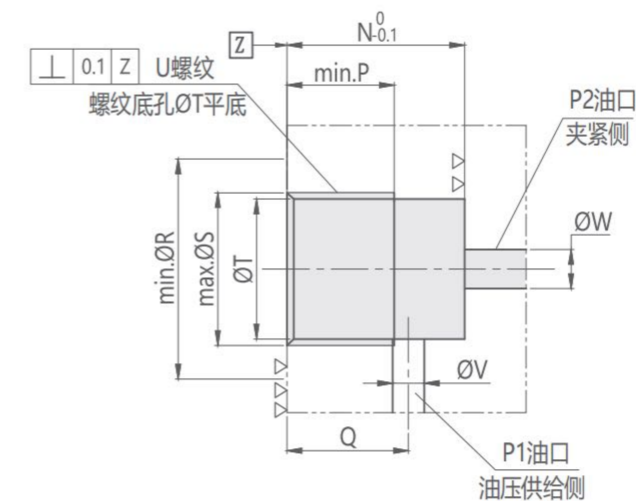

### 注意事项

- 1.▽▽▽部将成为密封面, 注意切勿受损。
- 2.▽▽部将成为CZT端面的金属密封面, 注意切勿受损。(去毛刺时注意)。
- 3.加工孔公差部位切勿残留削屑、毛刺等异物。
- 4.使用时请按图所示, 将P1油口设定为油压供给侧, 将P2油口设定为夹紧侧。
- 5.如安装市场上销售的G螺纹规格的堵头和接头时, 请将尺寸表内的[※1] 设定为12.5。
- 6.控制的产品容量较小时, 可能无法充分控制速度(推荐容量3cm³以上)。

### NOTE

1. As the ▽▽▽ area is sealing part, pay attention not to damage it.
2. As the ▽▽ area is the metal sealing part at the CZT side, pay attention not to damage it.(Notes for deburring).
3. Pay attention to have no cutting chips and burring at the tolerance part of the machining hole.
4. As shown in the drawing, P1-port is used as hydraulic supply and P2-port as the clamping supply.
5. If using a common plug and fitting with G thread specification are considered to be mounted, "※1" in the table should be 12.5.

Unit:mm

Model	A	B	C	D	E	F	G	H	J	K	L	M	N	P	Q	R	S	T	U	V	W
CZT-10	14	15.5	15	12	8.5	12.6	G1/8	3	3.5	10	3	M6x0.75	12.5	8.5	9.5	16	10	8.7	G1/8	2.5~3.5	2.5~5
CZT-20	18	20	16	13	9.5	16.1	G1/4	3	3.5	10	3	M6x0.75	16	11	12	20.5	13.5	11.5	G1/4	3.5~4.5	3.5~7

# CVCF

## 速度控制阀(低压用)

### CVCF SPEED CONTROL VALVE (LOW PRESSURE)



#### 注意事项

- 1.控制侧完全开放时的最小流道面积与上表的最大流道面积相等。
- 2.必须按本体推荐紧固力矩安装速度控制阀。速度控制阀端面为金属密封结构，紧固力矩不足将无法进行流量调整。
- 3.不可将曾经使用过的速度控制阀再用于其它油缸上。否则可能会因油缸的G螺纹底面深度差异而导致金属密封不严密,从而无法进行流量调整。

#### NOTE

1. Minimum passage area when fully opened is the same as the maximum passage area in the table above.
2. It must be mounted with recommended torque. Because of the structure of the metal seal, if mounting torque is insufficient, the flow control valve may not be able to adjust the flow rate.
3. Don't use used speed control valve to other clamps. Flow control will not be made because the bottom depth difference of G thread makes metal seal insufficient.

#### 订购标示法 ORDERING INDICATION

示例: CVCF-010

CVCF	系列 Series	CVCF
01	G螺纹尺寸 G thread size	01: 螺纹尺寸G1/8 Thread part G1/8 thread 02: 螺纹尺寸G1/4 Thread part G1/4 thread 03: 螺纹尺寸G3/8 Thread part G3/8 thread

0	控制方式 Control method	无记号: 进油节流 0: 回油节流	Meter-in Meter-out
		无记号	

安装孔加工图

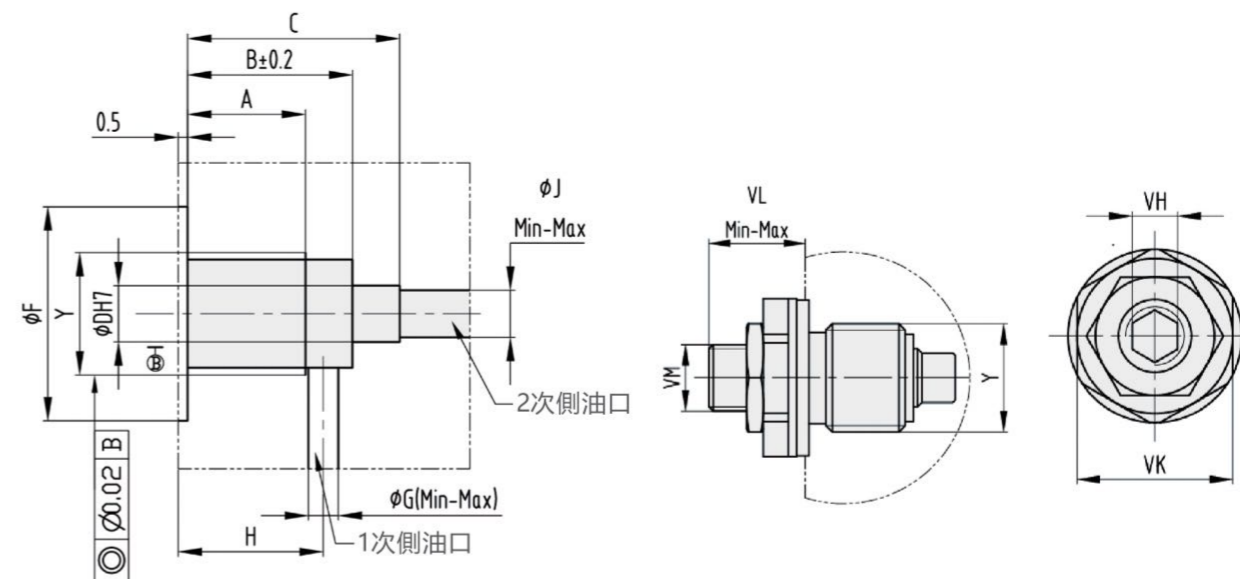

#### 规格参数表 SPECIFICATIONS

型号	最高使用压力	耐压	控制方式	G螺纹尺寸	开启压力	使用温度范围	本体推荐紧固力矩(N.m)	使用流体
MODEL	MAX. OPERATING PRESSURE(MPa)	WITHSTANDING PRESSURE(MPa)	CONTROL METHOD	G THREAD SIZE	CRACKING PRESSURE (MPa)	OPERATING TEMPERATURE(°C)	RECOMMEND TIGHTENING FOR MAIN BODY(N.m)	USABLE FLUID
CVCF-01	7	10.5	进油节流 Meter-in	G1/8	0.04	0~70°C	10	相当于ISO黏度等级的ISO-VG-32一般液压油 Recommended: ISO-VG-32 hydraulic oil equivalent to ISO viscosity grade
CVCF-02	7	10.5	进油节流 Meter-in	G1/4	0.04	0~70°C	30	
CVCF-03	7	10.5	进油节流 Meter-in	G3/8	0.04	0~70°C	35	
CVCF-010	7	10.5	回油节流 Meter-out	G1/8	0.12	0~70°C	10	
CVCF-020	7	10.5	回油节流 Meter-out	G1/4	0.12	0~70°C	30	
CVCF-030	7	10.5	回油节流 Meter-out	G3/8	0.12	0~70°C	35	

Unit:mm

Model	A	B	C	D	F	G	H	J	Y	VH	VK	VL	VM
CVCF-01	9	13	17.5	5 <sup>+0.012</sup> <sub>0</sub>	17.5	2.5~3	9.5~11.5	2.5~5	G1/8	3	12	7~11	M6×0.75
CVCF-010													
CVCF-02	13	18	22.5	6 <sup>+0.012</sup> <sub>0</sub>	21.5	3.5~5	14.5~15.5	3.5~6	G1/4	5	17	7.5~11.5	M8×0.75
CVCF-020													
CVCF-03	13	19	23.5	8 <sup>+0.015</sup> <sub>0</sub>	24.5	5~6	15~16	5~8	G3/8	6	19	8.5~12.5	M10×0.75
CVCF-030													

注:

1. 拆装时请用梅花扳手或套筒扳手。
2. 当夹紧器采用坐垫式配管时，流量控制阀可以安装在油压介面处(G螺纹部)。
3. 请在无油压状态下进行流量调整。否则会造成密封件损坏。
4. 左图表示进油节流(CVCF<sub>0</sub>)的安装状态。
5. 出厂时流量调整螺丝为全打开状态。夹紧器安装后要调整为全封闭状态后一点一点慢慢地调整动作速度。

# CVCH

## 速度控制阀（高压用）

### CVCH SPEED CONTROL VALVE(HIGH PRESSURE)



#### 安装孔加工图

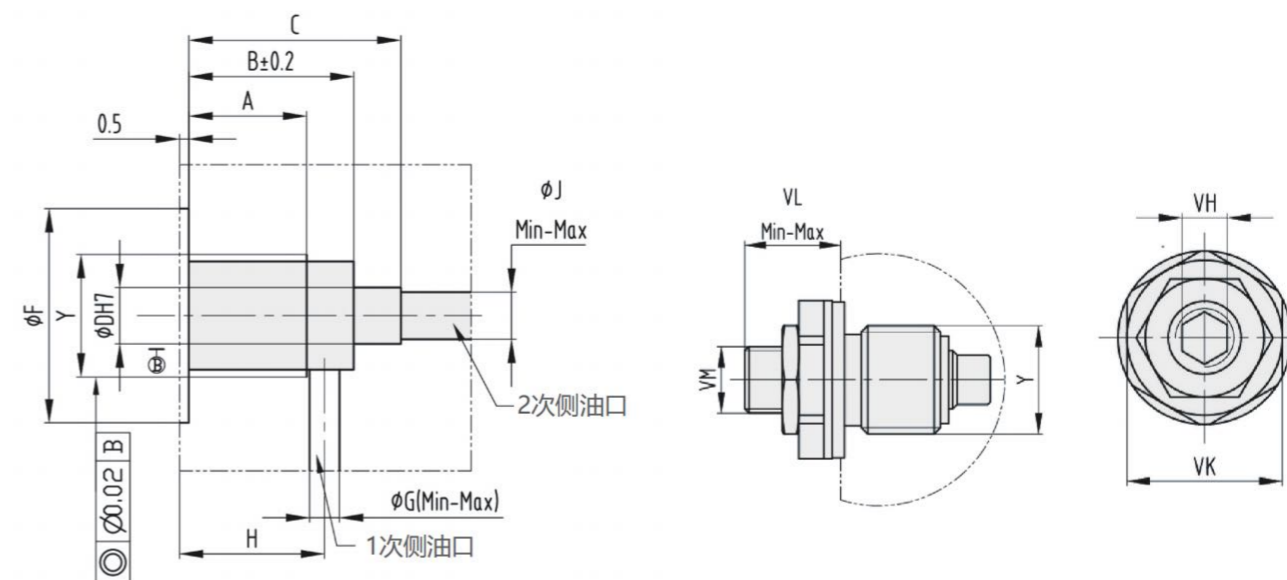

#### 注意事项

- 1.控制侧完全开启时的最小流道面积与上表的最大流道面积相等。
- 2.必须按本体推荐紧固力矩安装速度控制阀。速度控制阀端面为金属密封结构，紧固力矩不足将无法进行流量调整。
- 3.不可将曾经使用过的速度控制阀再用于其它油缸上。否则可能会因油缸的G螺纹底面深度差异而导致金属密封不严密，从而无法进行流量调整。

#### NOTE

1. Minimum passage area when fully opened is the same as the maximum passage area in the table above.
2. It must be mounted with recommended torque. Because of the structure of the metal seal, if mounting torque is insufficient, the flow control valve may not be able to adjust the flow rate.
3. Don't use used speed control valve to other clamps. Flow control will not be made because the bottom depth difference of G thread makes meta seal insufficient.

#### 订购标示法 ORDERING INDICATION

示例: CVCH-01

CVCH	系列 Series	CVCH
01	G螺纹尺寸 G thread size	01: 螺纹尺寸G1/8 02: 螺纹尺寸G1/4
无记号	控制方式 Control method	无记号: 进油节流 Meter-in  回路符号: 进油节流 Circuit symbols: Meter-in P1油口 P1 port 油压供给侧 Hydraulic pressure supply side P2油口 P2 port 夹紧侧 Clamp side

#### 规格参数表 SPECIFICATIONS

型号	最高使用压力	耐压	控制方式	G螺纹尺寸	开启压力	使用温度范围	本体推荐紧固力矩(N.m)	使用流体
Model	MAX. OPERATING PRESSURE(MPa)	WITHSTANDING PRESSURE(MPa)	CONTROL METHOD	G THREAD SIZE	CRACKING PRESSURE (MPa)	OPERATING TEMPERATURE(°C)	RECOMMEND TIGHTENING FOR MAIN BODY(N.m)	USABLE FLUID
CVCH-01	40	50	进油节流Meter-in	G1/8	0.04	0~70°C	10	相等于ISO粘度等级的ISO-VG-32一般液压油 Recommended: ISO-VG-32 hydraulic oil equivalent to ISO viscosity grade
CVCH-02	40	50	进油节流Meter-in	G1/4	0.04	0~70°C	30	

Model	A	B	C	D	F	G	H	J	Y	VH	VK	VL	VM
CVCH-01	9	13	17.5	5 <sup>+0.012</sup> <sub>0</sub>	17.5	2.5~3	9.5~11.5	2.5~5	G1/8	3	12	7~11	M6×0.75
CVCH-02	13	18	22.5	6 <sup>+0.012</sup> <sub>0</sub>	21.5	3.5~5	14.5~15.5	3.5~6	G1/4	5	17	7.5~11.5	M8×0.75

注:

- 1.拆装时请用梅花扳手或套筒扳手。
- 2.当夹紧器采用坐垫式配管时，流量控制阀可以安装在油压界面处（G螺纹部）。
- 3.请在无油压状态下进行流量调整。否则会造成密封件损坏。
- 4.左图表示进油节流（CVCH□）的安装状态。
- 5.出厂时流量调整螺丝为全打开状态。夹紧器安装后要调整为全封闭状态后一点一点慢慢地调整动作速度。
- 6.控制的产品容量较小时，可能无法充分控制速度（推荐容量3cm<sup>3</sup>以上）。

# CSV/CLSV

油压顺序阀

## CSV/CLSV HYDRAULIC SEQUENCE VALVE



### 产品特性

此型式油压顺序阀，适用于夹具回路，由压力决定油压缸之顺序动作，体积小，耐高压，安装于回路中，不需其他控制，即可得到顺序动作确实之效果。

本产品提供A:油路板型B:配管型两种型式，可依夹具整体设计安装方式需要作适当选择。

最大操作压力: 250kgf/cm<sup>2</sup> (CLSV:70kgf/cm<sup>2</sup>)  
最小操作压力: 25kgf/cm<sup>2</sup>

### 注意事项

多个顺序阀并联于回路中使用，相互间设定压力差不得小于10kgf/cm<sup>2</sup>。工作压力和设定压力差值必须要10kgf/cm<sup>2</sup>以上。请根据使用压力，选用合适动作弹簧。

#### CSV-A 油路板式

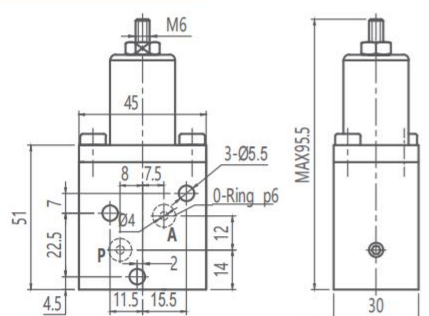

#### CSV-B 配管式

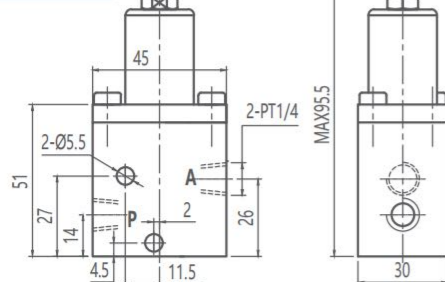

### FEATURES

This series of hydraulic sequence valve is especially ideal for your fitting on the circuit of the fixture. The hydraulic cylinder motion sequences are decided by the pressure. The sequence valve has the characteristics of small volume, compact structure and high pressure resistance. It requires no further control when fitting on the circle, and provides a positive sequential motion control. This series provides two types of mounting type for choice. A type is a manifold mounting type and B type are a line mounting type. You get a flexible choice of mounting types to suit your fixture design.

Max. operating pressure: 250kgf/cm<sup>2</sup> (CLSV:70kgf/cm<sup>2</sup>)  
Min. operation pressure: 25kgf/cm<sup>2</sup>

### NOTE

You should set the pressure difference not be less than 10 kgf/cm<sup>2</sup> when multiple sequence valves used in parallel circuit. Setting the pressure difference and working pressure must be exceeded 10kgf/cm<sup>2</sup>. Please choose the appropriate actuation spring according to the working pressure.

回路图 CIRCUIT DIAGRAM

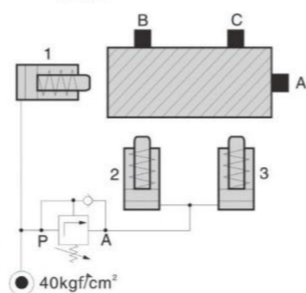

CLSV-A 油路板型 使用压力范围  
CLSV-B 配管式 25-70kgf/cm<sup>2</sup>

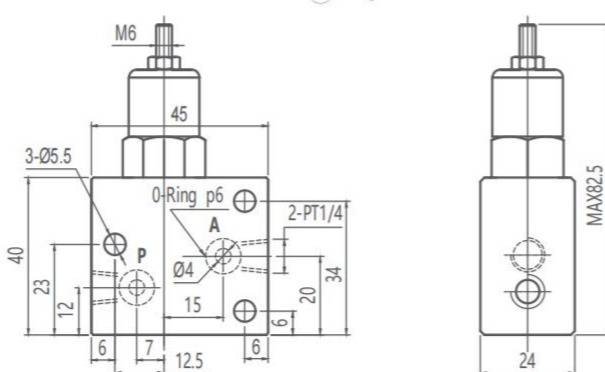

# CFCV/CFTC

油压流量阀

## CFCV/CFTC HYDRAULIC FLOW CONTROL VALVE

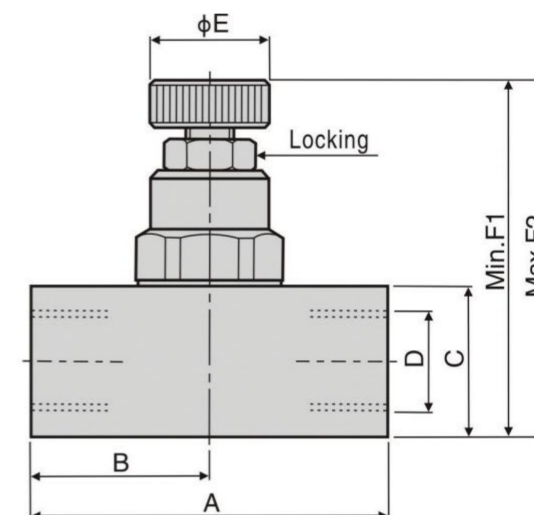
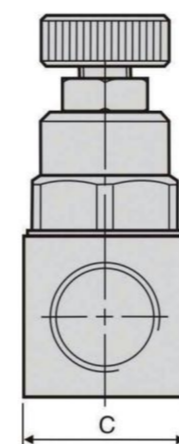

Max. operating pressure: 210 kgf/cm<sup>2</sup>

Unit:mm

Model	A	B	C	D	ΦE	F1	F2
CFCV-01	35	19	□15.9	PT1/8	Φ12	41	44.5
CFCV-02	45	22.5	□19	PT1/4	Φ15	45	48.5

使用流体: 相当于ISO黏度等级的ISO-VG-32一般液压油  
Recommended: ISO-VG-32 hydraulic oil equivalent to ISO viscosity grade

#### CFTC-02G-21A/31A板式油压流量阀

(注: CFTC-02G-31A是精密可调型)

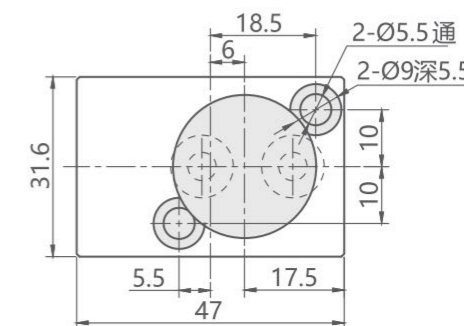
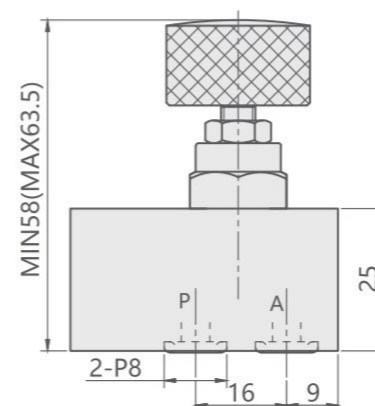

# CPRV

油压减压阀

## CPRV HYDRAULIC PRESSURE REDUCING VALVE

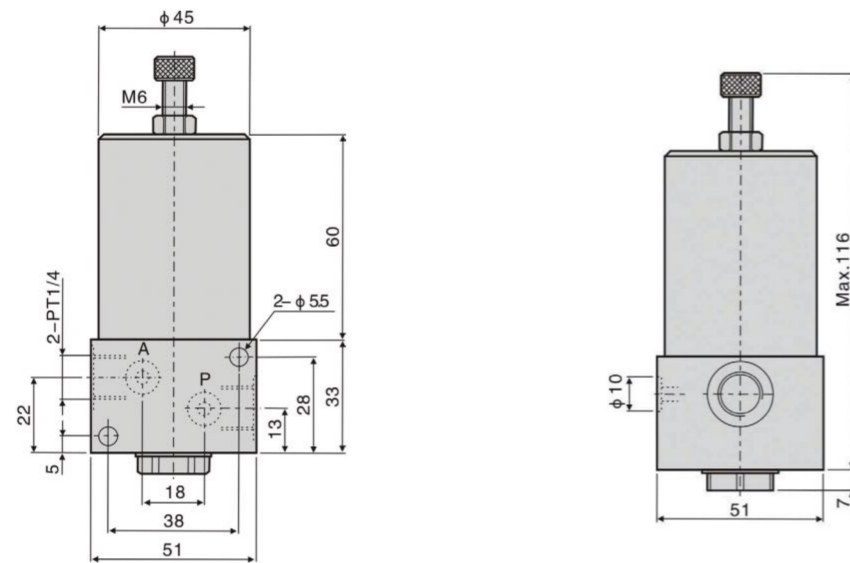

### CIRCUIT DIAGRAM

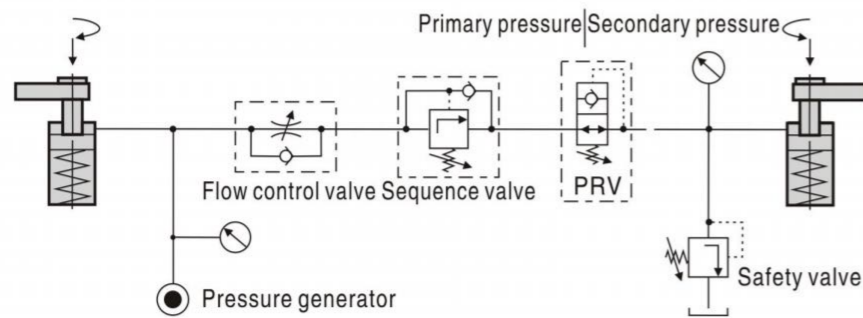

### 订购标示法 ORDERING INDICATION

示例: CPRV-M021

CPRV	系列 Series	CPRV
M	接管方式 Piping method	空白: 配管式 Blank: Line type M: 油路板型 M: Manifold type
02	型号 Model	A Manifold type
1	压力调整范围 Pressure range (kgf/cm <sup>2</sup> )	1 5-30
		2 10-50
		3 20-120
		4 30-240
		5 50-380

使用流体: 相当于ISO黏度等级的ISO-VG-32一般液压油  
Recommended: ISO-VG-32 hydraulic oil equivalent to ISO viscosity grade

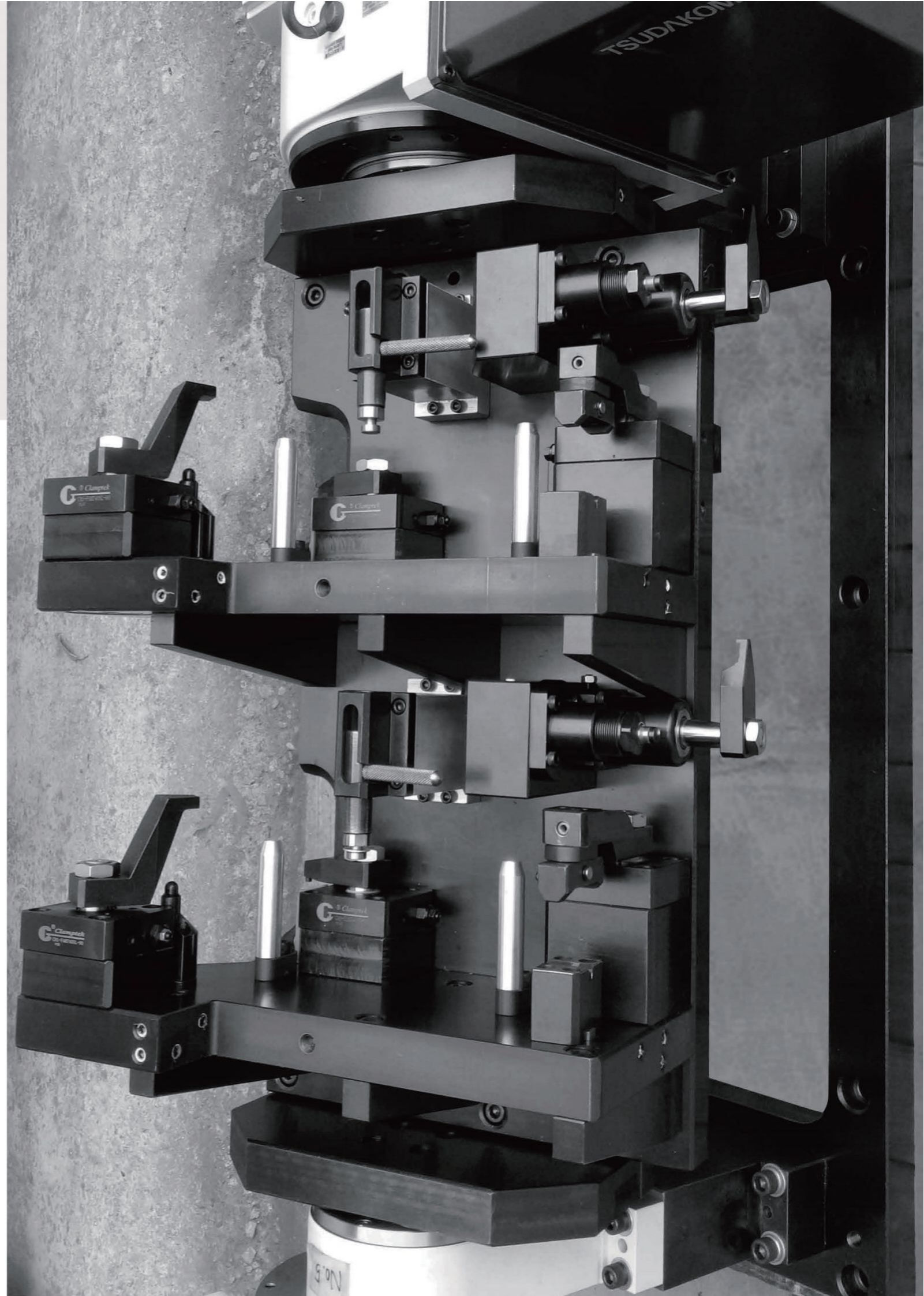

# 引导式减压阀

## PILOT OPERATED REDUCING VALVES

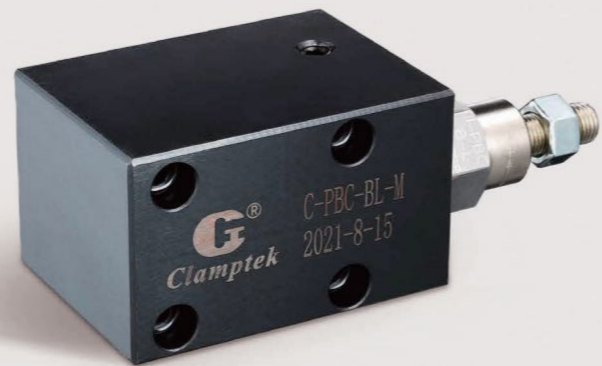

### 规格参数表 SPECIFICATIONS

型号	压力调整范围	最高使用压力	流量	使用温度	使用流体
MODEL	ACTUATING PRESSURE RANGE (MPa)	MAX.OPERATING PRESSURE (MPa)	RATED FLOW (l/min)	RANGE OF TEMPERATURE(°C)	USABLE FLUID
C-PBC-*	A:0.7-21MPa B:0.35-10.5MPa D:0.2-6MPa	21MPa	40L/min	0-70°C	相当于ISO粘度等级的ISO-VG-32 一般液压油Recommended: ISO-VG-32 hydraulic oil equivalent to ISO viscosity grade

### 订购标示法 ORDERING INDICATION

#### 示例: C-PBC-AL-T

<b>C</b>	系列 Series	C
<b>PBC</b>	规格 Valve Size	PBC: 40L/min
<b>A</b>	压力调整范围 Actuating pressure range(MPa)	A:0.7-21 B:0.35-10.5 D:0.2-6
<b>L</b>	旋钮型式 Knob Type	L:防漏,螺杆调整 Leakage Proof,Bolt rod Adjust
<b>T</b>	类型 Type	M: 油路板型 Manifold type T: 配管式: Line type

### C-PBC-※L-M 安装尺寸

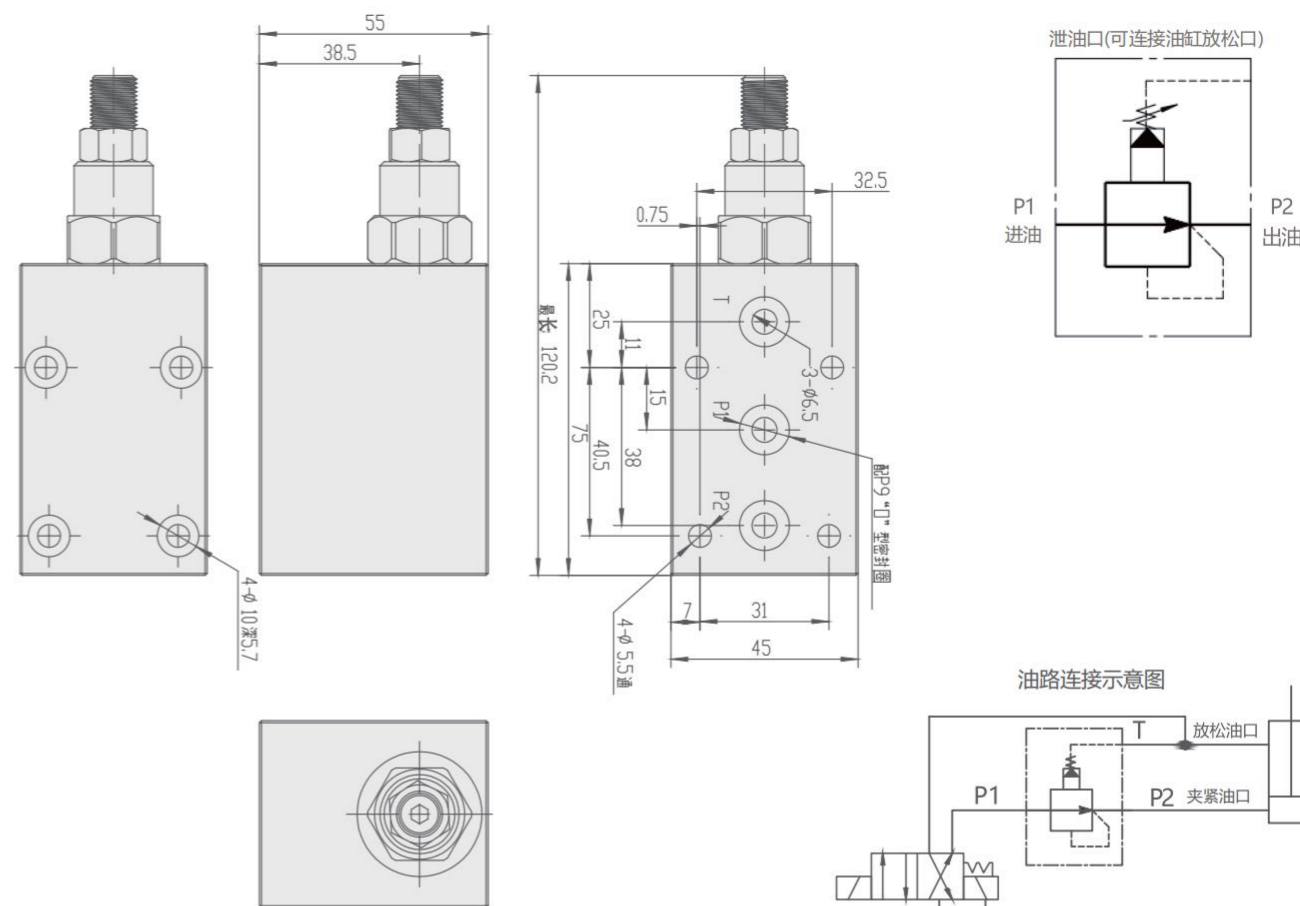

### C-PBC-※L-T 安装尺寸

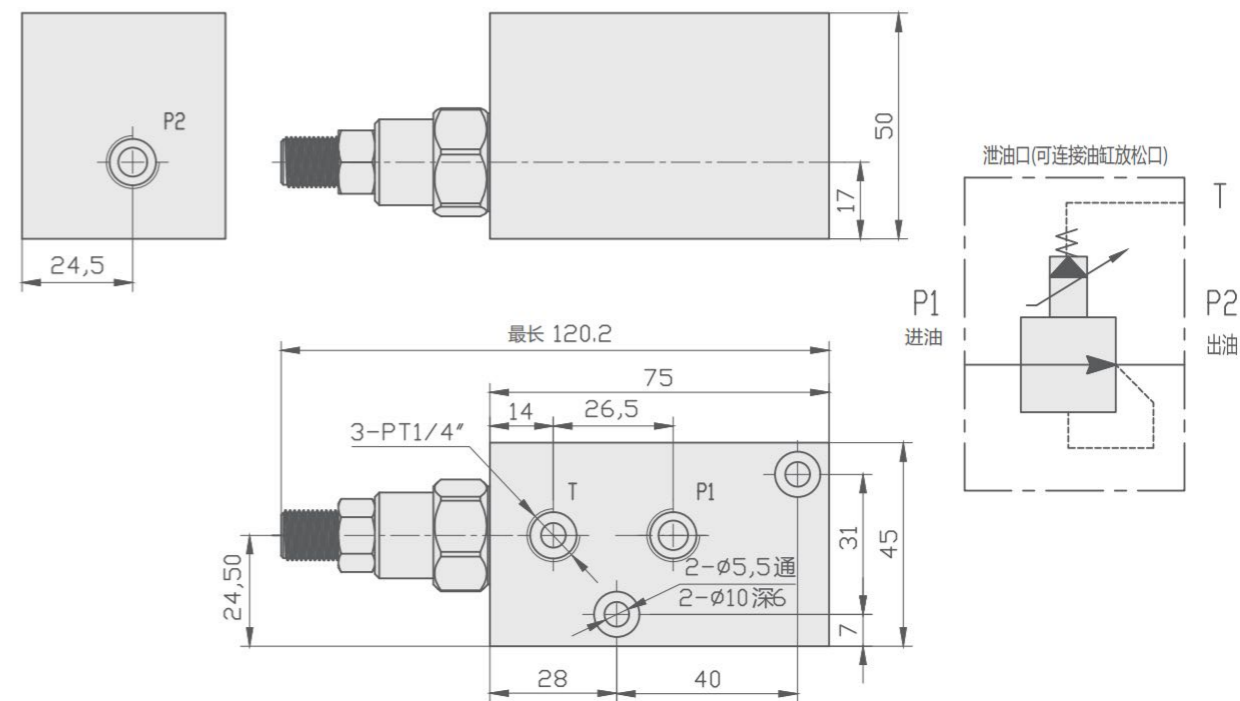

# 引导式顺序阀

## PILOT OPERATED SEQUENCE VALVES

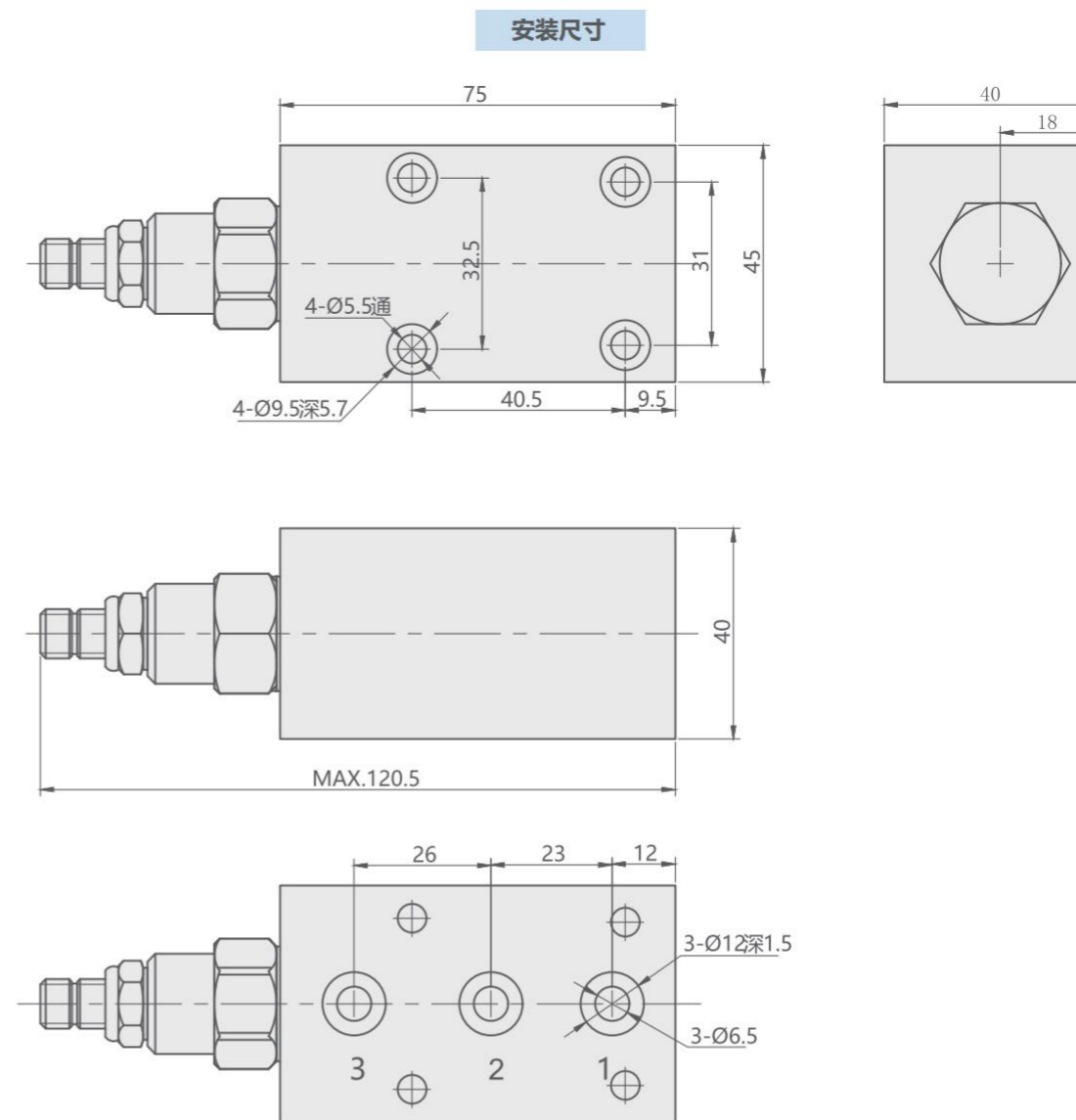

### 规格参数表 SPECIFICATIONS

型号	压力调整范围	最高使用压力	流量	使用温度	使用流体
MODEL	ACTUATING PRESSURE RANGE (MPa)	MAX. OPERATING PRESSURE (MPa)	RATED FLOW (l/min)	RANGE OF TEMPERATURE (°C)	USABLE FLUID
C-SCCA-LAN	3.5-21MPa	35MPa	60L/min	0-70°C	相当于ISO粘度等级的ISO-VG-32 一般液压油 Recommended: ISO-VG-32 hydraulic oil equivalent to ISO viscosity grade

### 订购标示法 ORDERING INDICATION

示例: C-SCCA-LAN

<b>C</b>	系列 Series	C
<b>SCCA</b>	规格 Valve Size	SCCA : 60L/min
<b>L</b>	旋钮型式 Knob Type	L: 螺杆调整 Bolt rod Adjust
<b>A</b>	压力调整范围 Actuating pressure range MPa	A:3.5-21MPa
<b>N</b>	密封件材料	N:丁腈橡胶

# CWD-B

气动顺序阀

## CWD-B PNEUMATIC SEQUENCE VALVE



### 产品特性 FEATURES

型号	最高使用压力	最低使用压力	耐压	延迟时间*1*2*3*4	最小通路面积	使用温度	重量	使用流体
MODEL	MAX. OPERATING PRESSURE(Mpa)	MIN. OPERATING PRESSURE(Mpa)	WITHSTANDING PRESSURE(Mpa)	DELAYED TIME * 1 * 2 * 3 * 4 (sec)	MIN.PASSAGE AREA (m <sup>2</sup> )	OPERATING TEMPERATURE(°C)	MASS (kg)	USABLE FLUID
CWD-B	0.6	0.2	1.5	1~10	4.0	0~70	0.2	OILED DRY CLEAN COMPRESSED AIR

### 注意事项

- 1.初始动作时的延迟时间可能因放置时间而延长。
- 2.可使用T埠增设储气箱，增加容量，从而延长延迟时间。
- 3.如果超过设定延迟时间2次侧执行元件仍未动作时，必须先将1次侧供给气压降到零，然后再进行确认作业。
- 4.确认延迟时间时应先拧紧延迟时间调整螺栓部的固定螺母后再行确认。

### NOTE

1. If unused for a long period of time, the delay is longer than initial set time.
- 2.It can extend the time delay from the tank and its capacity increases by using T port.
- 3.If actuators on outgoing side does not operate after the time delayed setting, verify setting after pressure returns to zero.
- 4.Confirmation for delayed time should be done after fastening the lock nut of the delayed time adjusting thread.

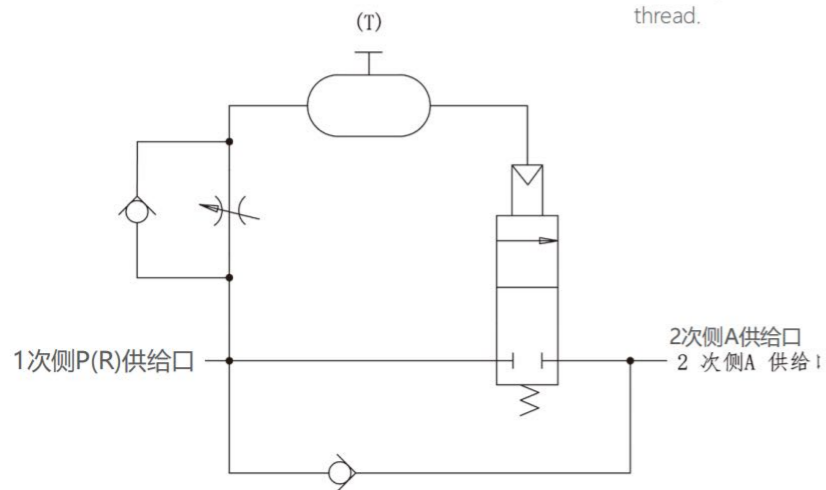

### 回路符号

※ 必须使用经过滤器过滤后的清洁空气，以免异物侵入内部。

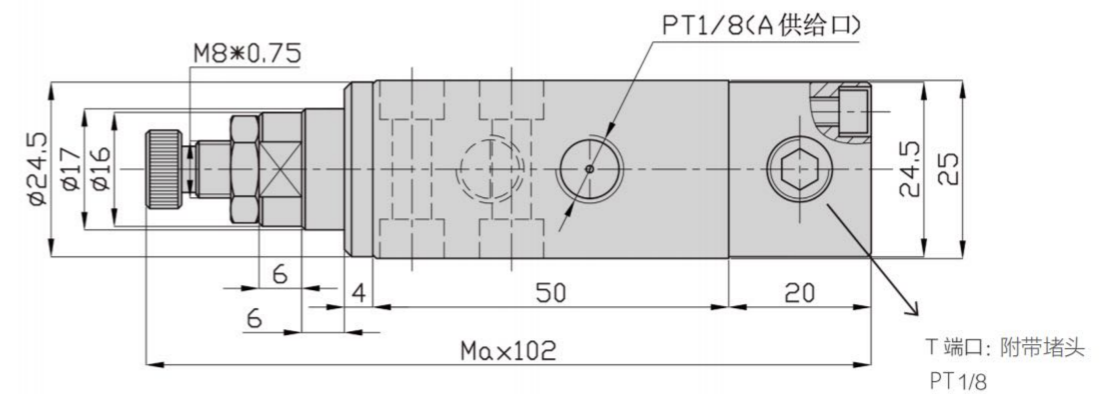
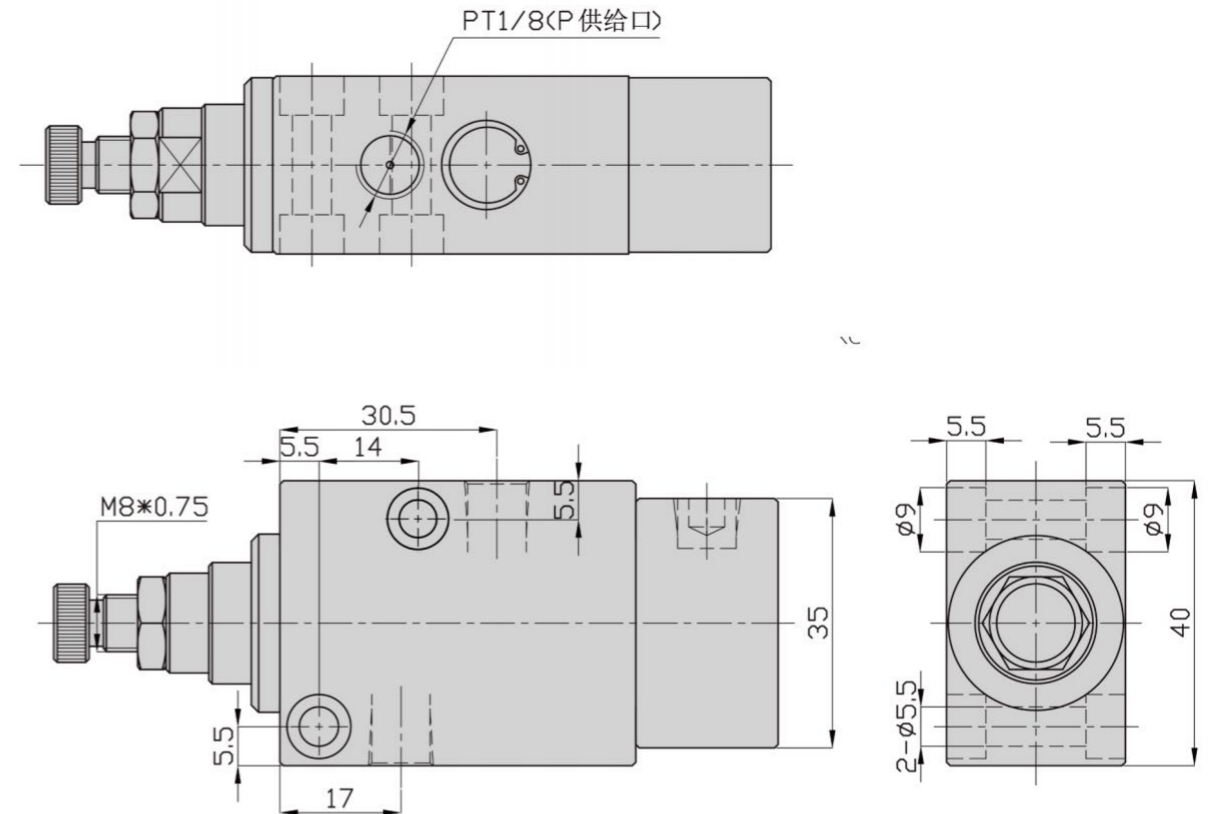

### 注意事项

实际延迟时间因回路条件而异。  
切勿过于拧紧或旋松延迟时间调整螺栓否则可能会导致产品的损伤。

### NOTE

The actual delay time owing to the different circuit conditions.  
Don't delay time is too tight or unscrew adjustment bolts, Otherwise it may cause product damage.

# CVP

## 无泄漏接头

### CVP LEAK-FREE JOINT



#### 产品特性

本接头介质用液压油、空气皆可；  
 最大使用压力25MPa；  
 不可在加压状态下连接、分离；  
 插头前端部采用特殊密封，分离状态下允许有压力；  
 插座最大可保持0.3MPa的残留压力。

#### FEATURES

This connector can be used with hydraulic oil or air at a maximum pressure of 25MPa. It cannot be connected or separated under pressure. The front end of the plug is specially sealed. Pressure is allowed in the separated state, and the socket can maintain a maximum residual pressure of 0.3MPa.

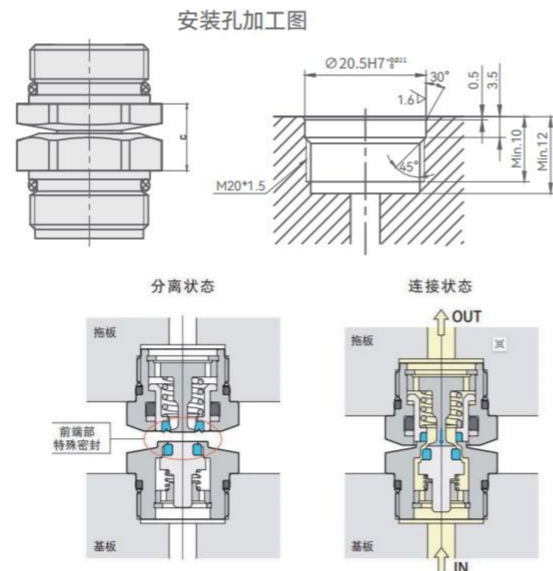
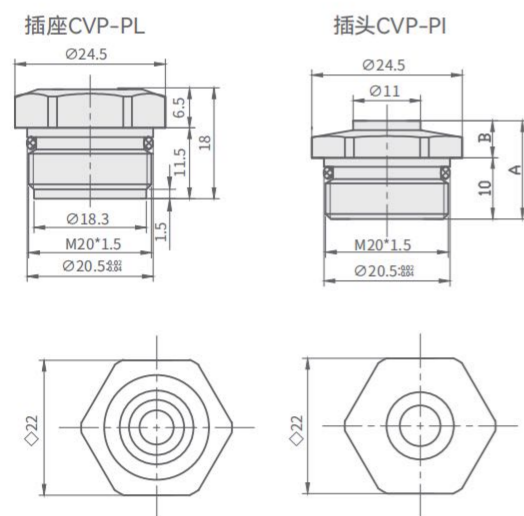

接头	插座	CVP-PL					
	插头	CVP-PI-01	CVP-PI-02	CVP-PI-03	CVP-PI-04	CVP-PI-05	CVP-PI-06
A		16	17	19	22	26	32
B		6	7	9	12	16	22
C		11.5	12.5	14.5	17.5	21.5	27.5

#### 注意事项:

- 如果在接头中有流体流动的状态下进行分离、连接，会导致流体泄漏到外部，因此进行分离、连接时，请停止供应流体。
- 接头中未内置过滤器进行连接时，为了防止异物进入，请务必事先进行空气清扫，防止连接处泄漏。
- 使用在液压回路中，内部应充分排气。
- 可以根据不同C值订做插头。

#### NOTE:

- If separation and connection are carried out when there is fluid flow in the joint, it will cause the fluid to leak to the outside. Therefore, when performing separation and connection, please stop the supply of fluid.
- There is no built-in filter in the joint, when making connections, to prevent foreign objects from entering, please be sure to clean the air in advance to avoid leakage at the connection points.
- When used in a hydraulic circuit, the interior should be fully vented.
- Plugs can be customized according to different C size.

# CJR旋转接头系列

## CJR SERIES ROTARY JOINTS

#### ● 剖面结构

可根据用途在以下四种规格中选择

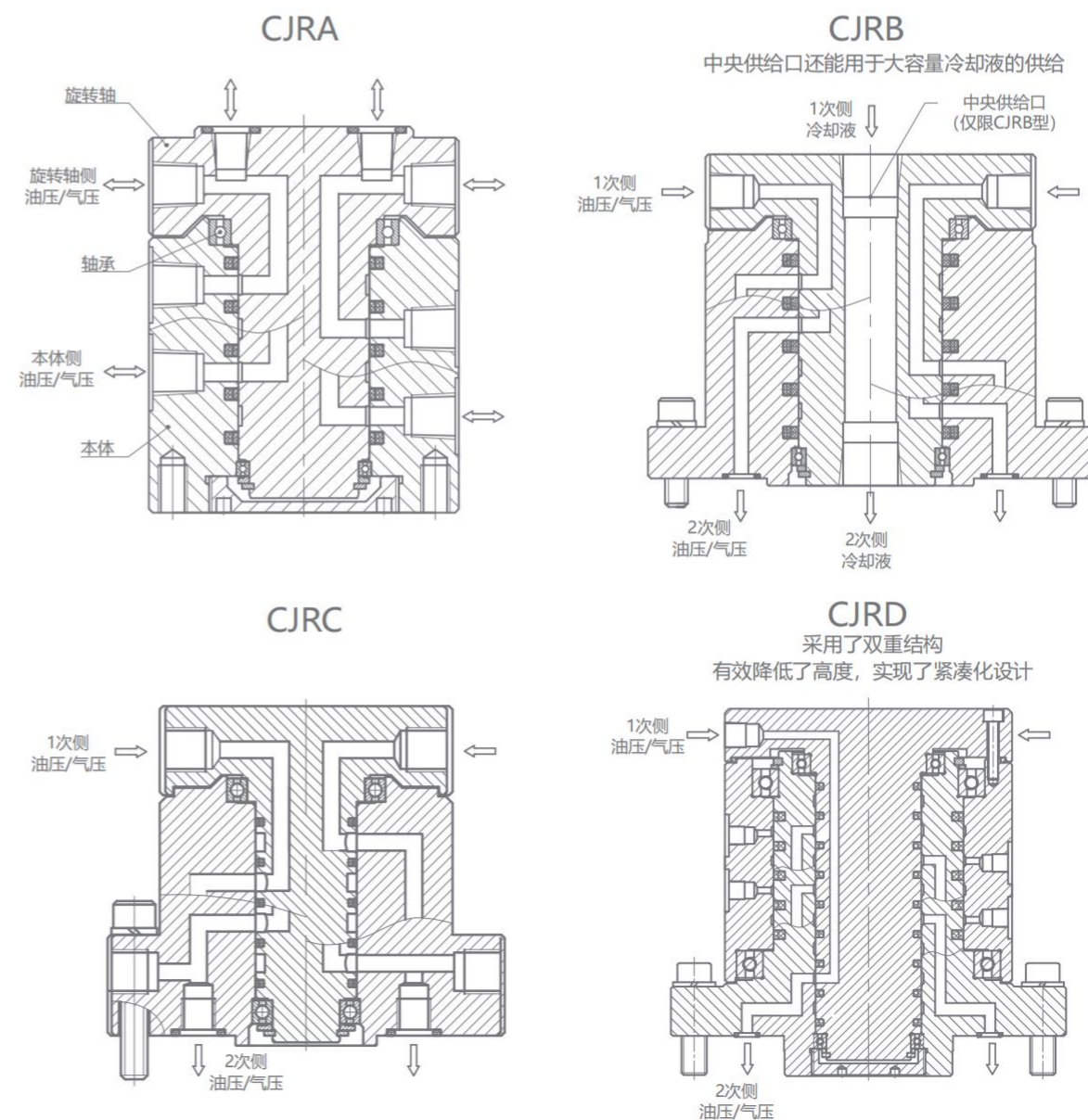

# CJRA

## 旋转接头

### CJRA ROTARY JOINT



#### 产品特性

旋转接头适用于油压、气压、大容量冷却液的供给。采用专业开发的低摩擦密封件，从而实现了低转矩，顺畅的旋转动作。此接头是兼具了刚性、耐久性、密封性的嘉刚公司设计的长寿命旋转接头，供给口数量可选择2、4、6、8供给口。

#### 注意事项

1. 油气并用时，油膜有可能渗入气压回路，请在两回路间设置排油口。
2. 连续运转会导致内部密封件发热，因此请避免连续运转。

#### 选配项 OPTIONS

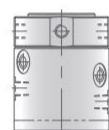

分类 CLASSIFICATION	供给口数量 THE NUMBER OF THE PORTS	特点 FEATURES	使用流体 USABLE FLUID
无中央供给口 No Center Through Port	2/4/6/8供给口 Port	低转矩(紧凑型) Low Rotary Torque (Compact Design)	一般液压油: 25MPa以下 General Hydraulic Oil: 25 MPa or less 气压: 1MPa以下 Air: 1MPa or Less

#### 订购标示法 ORDERING INDICATION

示例: CJRA-020SA

CJRA	系列Series	CJRA
02	供给口数量 The Number of the Ports	02: 2供给口 2 ports 04: 4供给口 4 ports 06: 6供给口 6 ports 08: 8供给口 8 ports
0	无中央供给口 Center Through Port	0: 无中央供给口 No Center Through Port
S	本体侧配管方式 Mounting Direction	B: 外配管式 (G螺纹) Piping Option (G-Thread)) S: 外配管式 (PT螺纹) Piping Option (PT-Thread))
A	旋转轴侧配管方式 Piping method on the side of the rotating shaft	D: 板式连接-外配管式 (G螺纹: 附带G螺纹堵头) D: Gasket and Piping Options (G-Thread Plug) A: 板式连接-外配管式 (PT螺纹: 附带PT螺纹堵头) A: Gasket and Piping Options (R-Thread Plug)

#### 注意事项

如需要上記配管方式以外的连接方式时，请另行咨询。

#### FEATURES

This product suitable for hydraulic & pneumatic and large-capacity cooling liquid supply. It adopts the original developed low friction seal and low torque enables smooth rotation. Each part of this rotary joint is highly durable and each seal provided by CLAMPTEK has low torque, highly durable and high capacity design that allows for a longer life of the component. You can select the number of ports from 2, 4, 6, 8 along with the center through port.

#### NOTE

1. Please prepare one circuit for drainage between them when the oil slick leak from the hydraulic circuit to adjacent air circuit becomes a problem.
2. Please avoid continuous operation as it will cause overheating and damage to the internal packing.

#### NOTE

Please contact us if you need a piping option different than what is shown in model code of catalogue.

型号	转矩(N·m)			
	CJRA-020	CJRA-040	CJRA-060	CJRA-080
流体压力(MPa)	□□	□□	□□	□□
25	3.6	5.2	10.8	14.4
20	2.9	4.2	9.1	12.0
15	2.3	3.4	7.5	9.8
10	1.8	2.6	5.9	7.7
7	1.6	2.2	5.0	6.4
0	1.0	1.4	3.0	3.6

#### 注意事项

1. 本图表示转矩(N·m)与流体压力(MPa)之间的关系。
2. 启动转矩偶尔会出现大于曲线图所示转矩2倍的情况，而且会因搁置时间等条件而发生变化。
3. 转矩仅为参考值。

型号	容许转速(min <sup>-1</sup> )			
	CJRA-020	CJRA-040	CJRA-060	CJRA-080
流体压力(MPa)	□□	□□	□□	□□
25	80		60	
14	160		125	
7	280		200	
2.5	390		280	

#### 注意事项

1. 本图表示容许旋转速度(min<sup>-1</sup>)与流体压力(MPa)之间的关系。
2. 即使在容许旋转速度以下，如果使用温度超出规格值时也是不可使用的。
3. 转速仅为参考值。

#### 规格参数表 SPECIFICATIONS

型号	使用压力 OPERATING PRESSURE (MPa)		供给口 PORTS	中央供给口	重量	使用温度	使用流体	
	油 OIL	空气 AIR						
MODEL			供给口数量 NUMBER	最小通路面积mm <sup>2</sup> MIN.PASSAGE AREA(mm <sup>2</sup> )	CENTER THROUGH PORT	WEIGHT (kg)	OPERATING TEMPERATURE(°C)	USABLE FLUID
CJRA-020□□	0~25.0	0~1.0	2	19.6	无Nothing	2.4	-10~70	普通液压油 或空气 Recommended: ISO-VG-32 hydraulic oil equivalent to ISO viscosity grade or dry air
CJRA-040□□	0~25.0	0~1.0	4	19.6	无Nothing	4.5	-10~70	
CJRA-060□□	0~25.0	0~1.0	6	19.6	无Nothing	7.8	-10~70	
CJRA-080□□	0~25.0	0~1.0	8	19.6	无Nothing	9.3	-10~70	

能力曲线图 (转矩: 参考值)

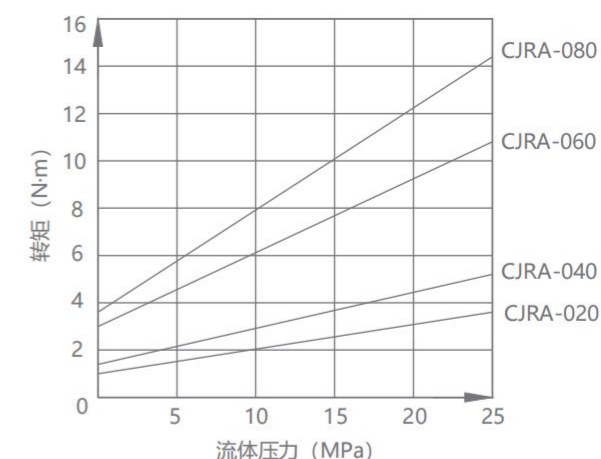

#### NOTE

1. This graph shows the relationship between torque (N·m) and fluid pressure (MPa).
2. The starting torque might be more than double of rotating torque shown in graphic and may change according to the conditions of the stationary down time. It varies according to the condition such as stationary down time.
3. The torque is only a reference value.

能力曲线图 (转矩: 参考值)

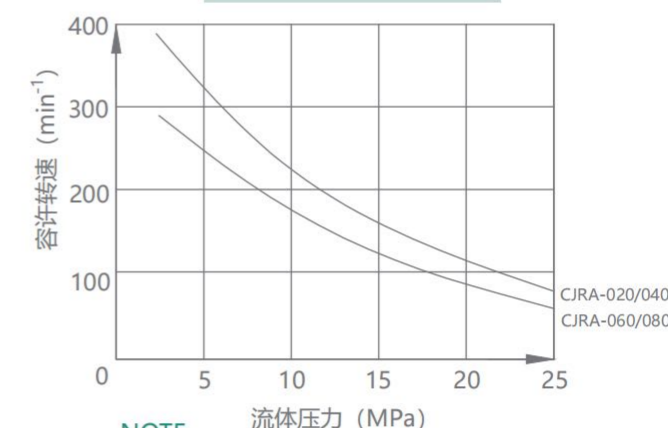

#### NOTE

1. This graph shows the relationship between the allowable rotational speed (min<sup>-1</sup>) and the fluid pressure (MPa).
2. Even below the allowable rotational speed, it cannot be used if the operating temperature exceeds the specified value.
3. The rotational speed is only a reference value.

## 外形尺寸: CJRA-020

### External Dimensions: CJRA-020

※本图表示CJRA-020SA(2回路)

本体侧供给口或旋转轴侧供给口需要G螺纹时, 请另行咨询。

※This drawing indicates CJRA-020SA(2 Port Circuit)

When G thread is necessary for the supply port on the body side or the supply port on the rotating axis side, please contact us separately.

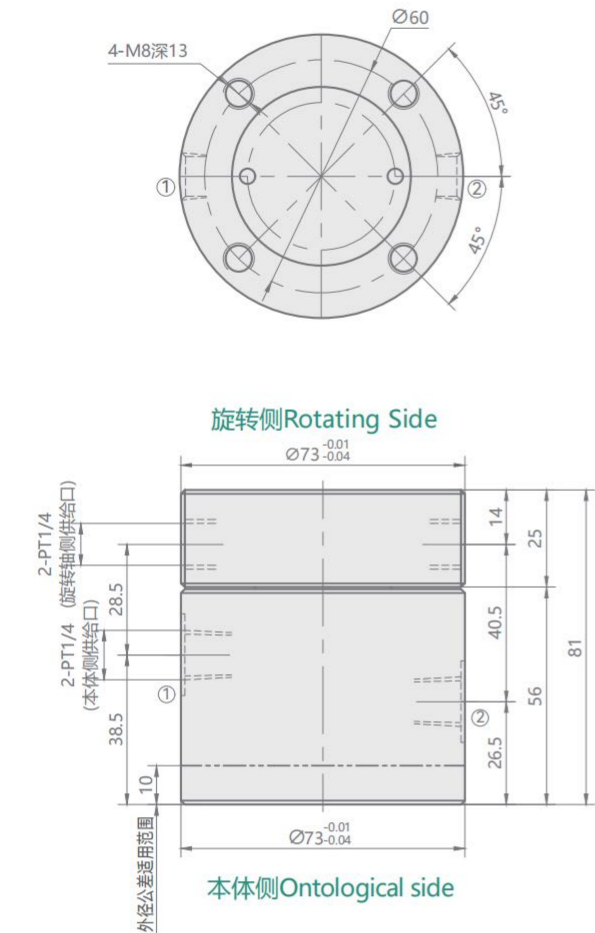

旋转侧Rotating Side

本体侧Ontological side

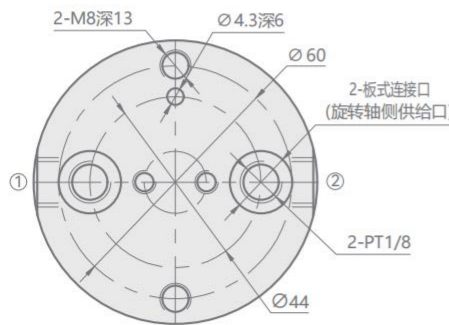

※1. 只有板式连接方式需要此项加工。

2. 安装面 (O型圈的密封面) 的表面粗糙度按6.3S加工。

※1. Only in the case of a gasket method, it is necessary  
2. Roughness of mounting surface (O-ring seal surface) should be 6.3s or less

安装部位加工尺寸  
Machining Dimensions of Mounting Area

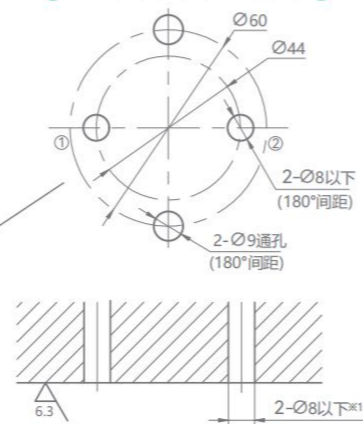

## 订购标示法 ORDERING INDICATION

### CJRA-020SA BD

B S: 本体侧配管方式

A D: 旋转轴侧配管方式 (B/D:G螺纹 S/A:PT螺纹)

B S: Piping method on the body side

A D: Piping method on the side of the rotating axis

(B/D: G thread S/A: PT thread)

1. 请只对旋转轴侧或者本体侧的一侧, 进行旋转方向的固定。
2. 旋转方向固定侧的配管请使用软管。
3. 油气并用时, 油膜有可能渗入气压回路, 请在两回路间设置残液排放回路。
4. 连续运转会导致内部密封件发热, 因此请避免连续运转。
5. 各供给口均标有接口编号。
6. 旋转轴侧使用PT1/4接口采用外配管方式时, 请使用附带的PT1/8螺纹堵头塞住板式连接口。
7. 当使用板式连接口时, 请安装O型密封圈和PT1/4螺纹堵头。
8. 安装旋转轴侧时, 请用4根安装螺栓以对角线的顺次慢慢的实施拧紧作业。(板式连接时)

1. Please only fix the rotation direction on one side of the rotating axis side or the main body side.
2. Please use flexible hoses for the piping on the fixed side of the rotation direction.
3. Please prepare one circuit for drainage between them when the oil slick leak from the hydraulic circuit to adjacent air circuit becomes a problem.
4. Please avoid continuous operation as it will cause overheating and damage to the internal packing.
5. Each port exhibits a port number.
6. When the PT1/4 interface is used on the rotating shaft side and the external piping method is adopted, please use the attached PT1/8 threaded plug to plug the plate connection port. When using gasket option, please attach O-ring and PT1/4 plug.
7. When installing the rotating shaft side, please use four installation bolts to slowly tighten them in a diagonal sequence. (Gasket option)

本体侧供给口:	Supply port on the body side
2-PT1/4螺纹	2-PT1/4 thread
旋转轴侧供给口:	Rotating axis side supply port
板式连接口:	Gasket-type connection port
2-O型密封圈-1BP12(附带)	2-O-ring -1BP12(included)
2-PT1/8螺纹-堵头(附带)	2-PT1/8 thread - Plug (included)
外配管型:	External piping type
2-PT1/4螺纹-堵头(附带)	2-PT1/4 thread - Plug (included)

## 外形尺寸: CJRA-040

### External Dimensions: CJRA-040

※本图表示CJRA-040SA(4回路)

本体侧供给口或旋转轴侧供给口需要G螺纹时, 请另行咨询。

※This drawing indicates CJRA-040SA(4 Port Circuit)

When G thread is necessary for the supply port on the body side or the supply port on the rotating axis side, please contact us separately.

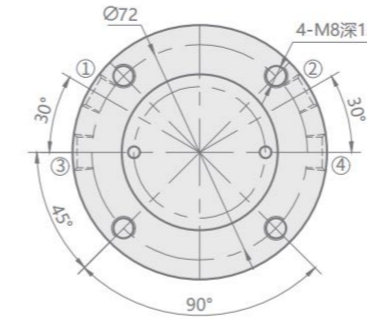

旋转侧Rotating Side

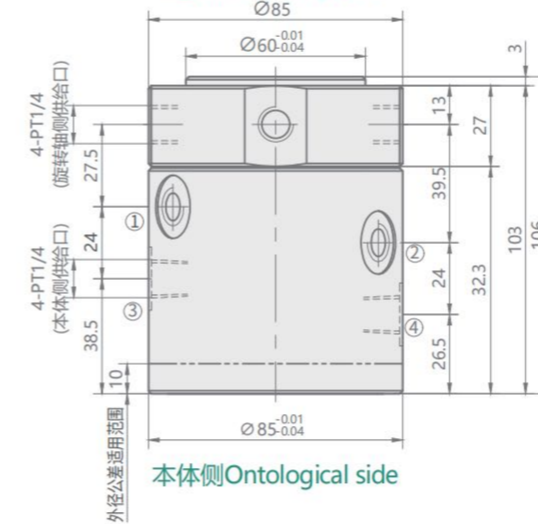

本体侧Ontological side

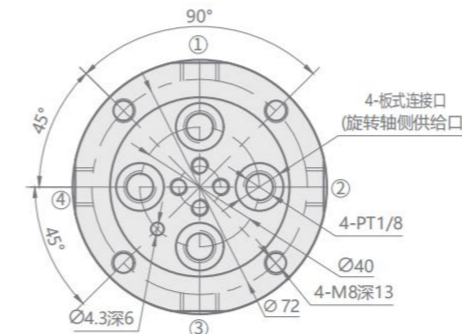

※1. 只有板式连接方式需要此项加工。

2. 安装面 (O型圈的密封面) 的表面粗糙度按6.3S加工。

※1. Only in the case of a gasket method, it is necessary  
2. Roughness of mounting surface (O-ring seal surface) should be 6.3s or less

安装部位加工尺寸  
Machining Dimensions of Mounting Area

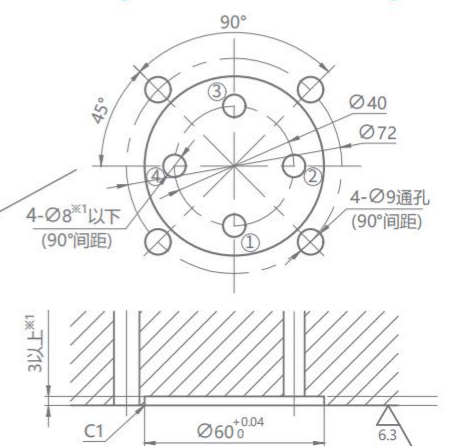

## 订购标示法 ORDERING INDICATION

### CJRA-040SA BD

B S: 本体侧配管方式

A D: 旋转轴侧配管方式 (B/D:G螺纹 S/A:PT螺纹)

B S: Piping method on the body side

A D: Piping method on the side of the rotating axis

(B/D: G thread S/A: PT thread)

1. 请只对旋转轴侧或者本体侧的一侧, 进行旋转方向的固定。
2. 旋转方向固定侧的配管请使用软管。
3. 油气并用时, 油膜有可能渗入气压回路, 请在两回路间设置残液排放回路。
4. 连续运转会导致内部密封件发热, 因此请避免连续运转。
5. 各供给口均标有接口编号。
6. 旋转轴侧使用PT1/4接口采用外配管方式时, 请使用附带的PT1/8螺纹堵头塞住板式连接口。
7. 当使用板式连接口时, 请安装O型密封圈和PT1/4螺纹堵头。
8. 安装旋转轴侧时, 请用4根安装螺栓以对角线的顺次慢慢的实施拧紧作业。(板式连接时)

1. Please only fix the rotation direction on one side of the rotating axis side or the main body side.
2. Please use flexible hoses for the piping on the fixed side of the rotation direction.
3. Please prepare one circuit for drainage between them when the oil slick leak from the hydraulic circuit to adjacent air circuit becomes a problem.
4. Please avoid continuous operation as it will cause overheating and damage to the internal packing.
5. Each port exhibits a port number.
6. When the PT1/4 interface is used on the rotating shaft side and the external piping method is adopted, please use the attached PT1/8 threaded plug to plug the plate connection port. When using gasket option, please attach O-ring and PT1/4 plug.
7. When installing the rotating shaft side, please use four installation bolts to slowly tighten them in a diagonal sequence. (Gasket option)

本体侧供给口:	Supply port on the body side
4-PT1/4螺纹	4-PT1/4 thread
旋转轴侧供给口:	Rotating axis side supply port
板式连接口:	Gasket-type connection port
4-O型密封圈-1BP12(附带)	4-O-ring -1BP12(included)
4-PT1/8螺纹-堵头(附带)	4-PT1/8 thread - Plug (included)
外配管型:	External piping type
4-PT1/4螺纹-堵头(附带)	4-PT1/4 thread - Plug (included)

## 外形尺寸: CJRA-060

### External Dimensions: CJRA-060

※本图表示CJRA-060SA(6回路)

本体侧供给口或旋转轴侧供给口需要G螺纹时, 请另行咨询。

※This drawing indicates CJRA-060SA(6 Port Circuit)

When G thread is necessary for the supply port on the body side or the supply port on the rotating axis side, please contact us separately.

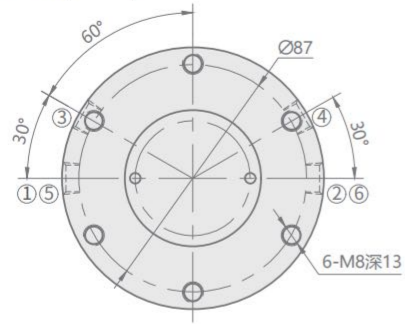

#### 旋转侧Rotating Side

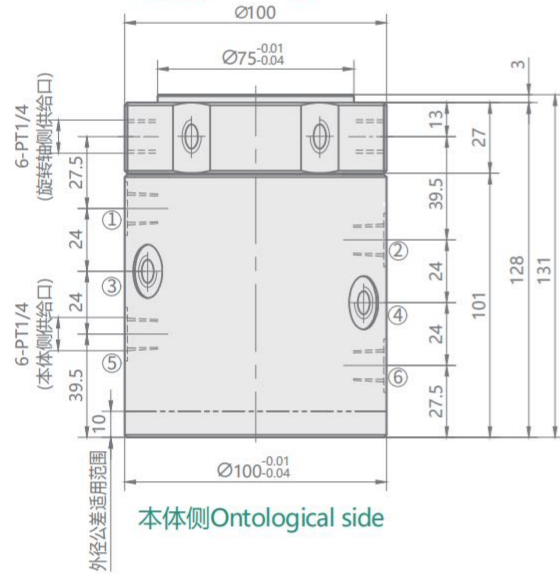

#### 本体侧Ontological side

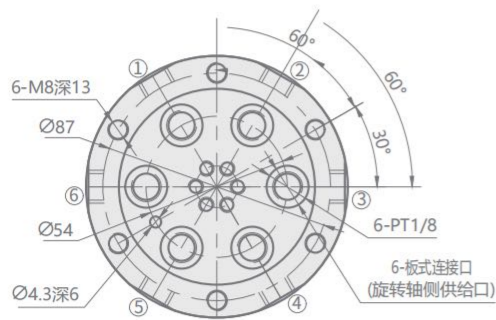

- ※1. 只有板式连接方式需要此项加工。
2. 安装面 (O型圈的密封面) 的表面粗糙度按6.3S加工。

※1. Only in the case of a gasket method, it is necessary  
2. Roughness of mounting surface (O-ring seal surface) should be 6.3s or less

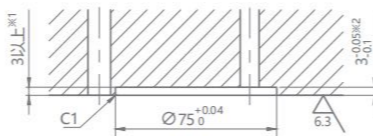

## 订购标示法 ORDERING INDICATION

### CJRA-060SA BD

B S: 本体侧配管方式

A D: 旋转轴侧配管方式 (B/D:G螺纹 S/A:PT螺纹)

B S: Piping method on the body side

A D: Piping method on the side of the rotating axis

(B/D: G thread S/A: PT thread)

1. 请只对旋转轴侧或者本体侧的一侧, 进行旋转方向的固定。
2. 旋转方向固定侧的配管请使用软管。
3. 油气并用时, 油膜有可能渗入气压回路, 请在两回路间设置残液排放回路。
4. 连续运转会导致内部密封件发热, 因此请避免连续运转。
5. 各供给口均标有接口编号。
6. 旋转轴侧使用PT1/4接口采用外配管方式时, 请使用附带的PT1/8螺纹堵头塞住板式连接口。
7. 安装旋转轴侧时, 请用4根安装螺栓以对角线的顺次慢慢的实施拧紧作业。(板式连接时)

1. Please only fix the rotation direction on one side of the rotating axis side or the main body side.
2. Please use flexible hoses for the piping on the fixed side of the rotation direction.
3. Please prepare one circuit for drainage between them when the oil slick leak from the hydraulic circuit to adjacent air circuit becomes a problem.
4. Please avoid continuous operation as it will cause overheating and damage to the internal packing.
5. Each port exhibits a port number.
6. When the PT1/4 interface is used on the rotating shaft side and the external piping method is adopted, please use the attached PT1/8 threaded plug to plug the plate connection port. When using gasket option, please attach O-ring and PT1/4 plug.
7. When installing the rotating shaft side, please use four installation bolts to slowly tighten them in a diagonal sequence. (Gasket option)

本体侧供给口:	Supply port on the body side
6-PT1/4螺纹	6-PT1/4 thread
旋转轴侧供给口:	Rotating axis side supply port
板式连接口:	Gasket-type connection port
6-O型密封圈-1BP12(附带)	6-O-ring -1BP12(included)
6-PT1/8螺纹-堵头(附带)	6-PT1/8 thread - Plug (included)
外配管型:	External piping type
6-PT1/4螺纹-堵头(附带)	6-PT1/4 thread - Plug (included)

#### 安装部位加工尺寸 Machining Dimensions of Mounting Area

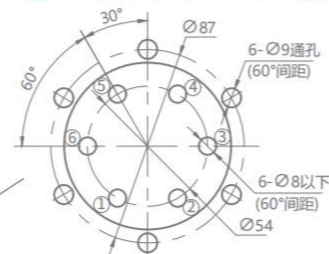

## 外形尺寸: CJRA-080

### External Dimensions: CJRA-080

※本图表示CJRA-080SA(8回路)

本体侧供给口或旋转轴侧供给口需要G螺纹时, 请另行咨询。

※This drawing indicates CJRA-080SA(8 Port Circuit)

When G thread is necessary for the supply port on the body side or the supply port on the rotating axis side, please contact us separately.

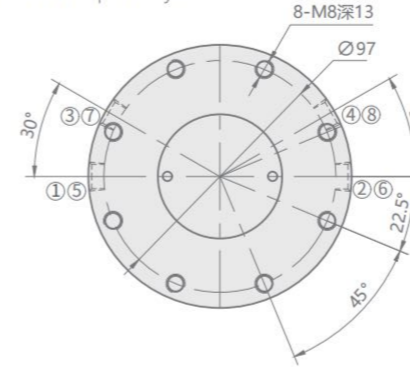

#### 旋转侧Rotating Side

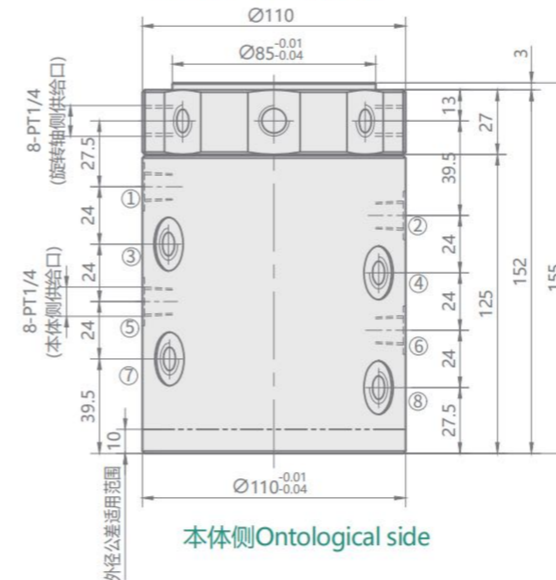

#### 本体侧Ontological side

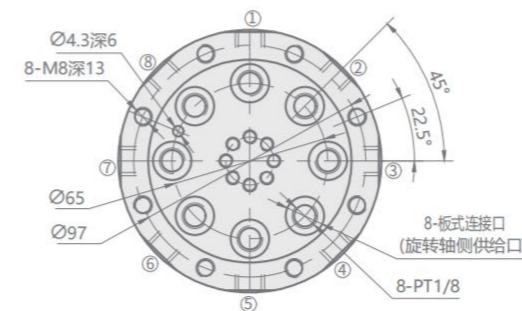

- ※1. 只有板式连接方式需要此项加工。
2. 安装面 (O型圈的密封面) 的表面粗糙度按6.3S加工。

※1. Only in the case of a gasket method, it is necessary  
2. Roughness of mounting surface (O-ring seal surface) should be 6.3s or less

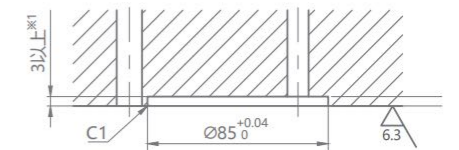

## 订购标示法 ORDERING INDICATION

### CJRA-080SA BD

B S: 本体侧配管方式

A D: 旋转轴侧配管方式 (B/D:G螺纹 S/A:PT螺纹)

B S: Piping method on the body side

A D: Piping method on the side of the rotating axis

(B/D: G thread S/A: PT thread)

1. 请只对旋转轴侧或者本体侧的一侧, 进行旋转方向的固定。
2. 旋转方向固定侧的配管请使用软管。
3. 油气并用时, 油膜有可能渗入气压回路, 请在两回路间设置残液排放回路。
4. 连续运转会导致内部密封件发热, 因此请避免连续运转。
5. 各供给口均标有接口编号。
6. 旋转轴侧使用PT1/4接口采用外配管方式时, 请使用附带的PT1/8螺纹堵头塞住板式连接口。
7. 安装旋转轴侧时, 请用4根安装螺栓以对角线的顺次慢慢的实施拧紧作业。(板式连接时)

1. Please only fix the rotation direction on one side of the rotating axis side or the main body side.
2. Please use flexible hoses for the piping on the fixed side of the rotation direction.
3. Please prepare one circuit for drainage between them when the oil slick leak from the hydraulic circuit to adjacent air circuit becomes a problem.
4. Please avoid continuous operation as it will cause overheating and damage to the internal packing.
5. Each port exhibits a port number.
6. When the PT1/4 interface is used on the rotating shaft side and the external piping method is adopted, please use the attached PT1/8 threaded plug to plug the plate connection port. When using gasket option, please attach O-ring and PT1/4 plug.
7. When installing the rotating shaft side, please use four installation bolts to slowly tighten them in a diagonal sequence. (Gasket option)

本体侧供给口:	Supply port on the body side
8-PT1/4螺纹	8-PT1/4 thread
旋转轴侧供给口:	Rotating axis side supply port
板式连接口:	Gasket-type connection port
8-O型密封圈-1BP12(附带)	8-O-ring -1BP12(included)
8-PT1/8螺纹-堵头(附带)	8-PT1/8 thread - Plug (included)
外配管型:	External piping type
8-PT1/4螺纹-堵头(附带)	8-PT1/4 thread - Plug (included)

#### 安装部位加工尺寸 Machining Dimensions of Mounting Area

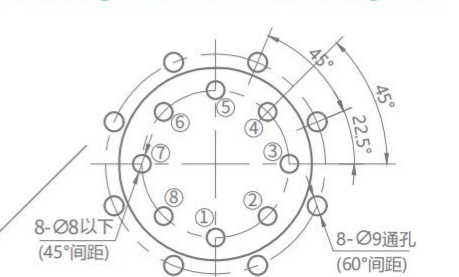

# CJRB

## 旋转接头

### CJRB ROTARY JOINT



#### 产品特性

旋转接头适用于油压、气压、大容量冷却液的供给。采用专业开发的低摩擦密封件，从而实现了低转矩，顺畅的旋转动作。此接头是兼具了刚性、耐久性、密封性的嘉刚公司设计的长寿命旋转接头，供给口数量可选择2、4、6、8供给口。

#### FEATURES

This product suitable for hydraulic & pneumatic and large-capacity cooling liquid supply. It adopts the original developed low friction seal and low torque enables smooth rotation. Each part of this rotary joint is highly durable and each seal provided by CLAMPTEK has low torque, highly durable and high capacity design that allows for a longer life of the component. You can select the number of ports from 2, 4, 6, 8 along with the center through port.

#### 注意事项

1. 油气并用时，油膜有可能渗入气压回路，请在两回路间设置排油口。
2. 连续运转会导致内部密封件发热，因此请避免连续运转。

#### NOTE

1. Please prepare one circuit for drainage between them when the oil leak from the hydraulic circuit to adjacent air circuit becomes a problem.
2. Please avoid continuous operation as it will cause overheating and damage to the internal packing.

#### 选配项 OPTIONS

分类 CLASSIFICATION	供给口数量 THE NUMBER OF THE PORTS	特点 FEATURES	使用流体 USABLE FLUID
 无中央供给口 No Center Through Port	2/4/6/8供给口 Port	低转矩(紧凑型) Low Rotary Torque (Compact Design)	一般液压油: 25MPa以下 General Hydraulic Oil: 25 MPa or less 气压: 1MPa以下 Air: 1MPa or Less

#### 示例: CJRB-021SGS

CJRB	系列Series	CJRB
02	供给口数量 The Number of the Ports	02: 2供给口 2 ports 04: 4供给口 4 ports 06: 6供给口 6 ports 08: 8供给口 8 ports
1	有中央供给口 Center Through Port	1: 有中央供给口 1 Center Through Port
S	1侧配管方式 Mounting Direction	B: 外配管式 (G螺纹) Piping Option (G-Thread) S: 外配管式 (PT螺纹) Piping Option (PT-Thread)
G	2侧配管方式 Mounting Direction	G: 板式连接型 (附带O环密封圈) G: Gasket option (O-ring included)
S	中央供给口配管方式 Piping method on the center supply port	B: 外配管式 (G螺纹) Piping Option (G-Thread) S: 外配管式 (PT螺纹) Piping Option (PT-Thread)

#### 注意事项

如需要上記配管方式以外的连接方式时，请另行咨询。

#### NOTE

Please contact us if you need a piping option different than what is shown in model code of catalogue.

型号	转矩(N·m)			
流体压力(MPa)	CJRB-021 □G□	CJRB-041 □G□	CJRB-061 □G□	CJRB-081 □G□
25	9.6	14.6	20.0	26.0
20	7.6	12.0	16.2	21.0
15	5.7	9.3	13.0	16.5
10	4.2	6.8	10.0	12.7
7	3.5	5.7	8.5	10.5
0	2.2	3.8	5.3	6.8

#### 注意事项

1. 本图表示转矩(N·m)与流体压力(MPa)之间的关系。
2. 启动转矩偶尔会出现大于曲线图所示转矩2倍的情况，而且会因搁置时间等条件而发生变化。
3. 转矩仅为参考值。

能力曲线图 (转矩: 参考值)

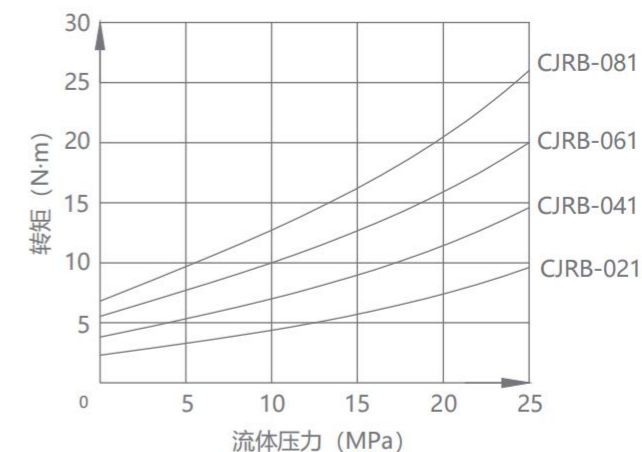

#### NOTE

1. This graph shows the relationship between torque (N·m) and fluid pressure (MPa).
2. The starting torque might be more than double of rotating torque shown in graphic and may change according to the conditions of the stationary down time. It varies according to the condition such as stationary down time.
3. The torque is only a reference value.

型号	容许转速(min <sup>-1</sup> )			
流体压力(MPa)	CJRB-021 □G□	CJRB-041 □G□	CJRB-061 □G□	CJRB-081 □G□
25		40		
14		90		
7		140		
2.5		200		

#### 注意事项

1. 本图表示容许旋转速度(min<sup>-1</sup>)与流体压力(MPa)之间的关系。
2. 即使在容许旋转速度以下，如果使用温度超出规格值时也是不可使用的。
3. 转速仅为参考值。

能力曲线图 (转速: 参考值)

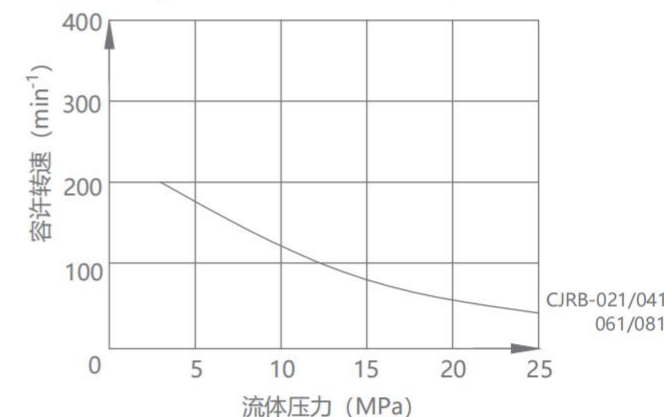

#### NOTE

1. This graph shows the relationship between the allowable rotational speed (min<sup>-1</sup>) and the fluid pressure (MPa).
2. Even below the allowable rotational speed, it cannot be used if the operating temperature exceeds the specified value.
3. The rotational speed is only a reference value.

#### 规格参数表 SPECIFICATIONS

型号 MODEL	使用压力 OPERATING PRESSURE (MPa)		供给口 PORTS		中央供给口 CENTER THROUGH PORT	重量 WEIGHT (kg)	使用温度 OPERATING TEMPERATURE(°C)	使用流体 USABLE FLUID
	油 OIL	空气 AIR	供给口数量 NUMBER	最小通路面积mm <sup>2</sup> MIN.PASSAGE AREA(mm <sup>2</sup> )				
CJRB-021□G□	0~25.0	0~1.0	2	28.3	有	7.5	-10~70	普通液压油 或空气 Recommended: ISO-VG-32 hydraulic oil equivalent to ISO viscosity grade or dry air
CJRB-041□G□	0~25.0	0~1.0	4	28.3	有	10.0	-10~70	
CJRB-061□G□	0~25.0	0~1.0	6	28.3	有	12.5	-10~70	
CJRB-081□G□	0~25.0	0~1.0	8	28.3	有	15	-10~70	

## 外形尺寸: CJRB-021S

### External Dimensions: CJRB-021S

※本图表示CJRB-021SGS(2回路+1中央供给口)

1次侧供给口或中央供给口需要G螺纹时, 请另行咨询。  
(中央供给口通过转换接头对应)

※This drawing indicates CJRB-021SGS(2 Port Circuit+1 Center supply port)  
When G thread is necessary for a primary port side or the center supply port, please contact us separately. (The central supply port is corresponding through a conversion joint.)

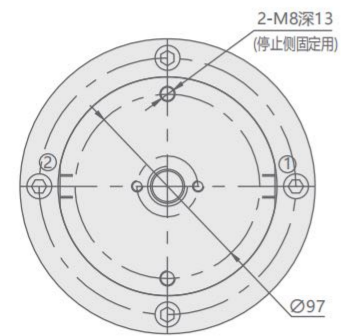
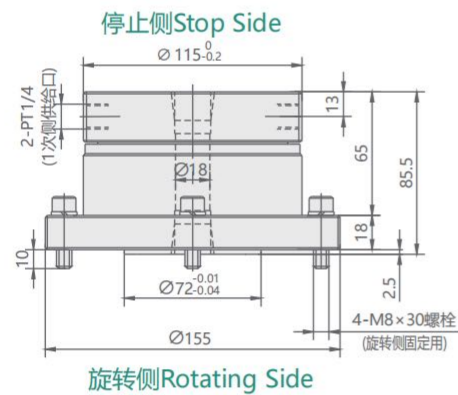
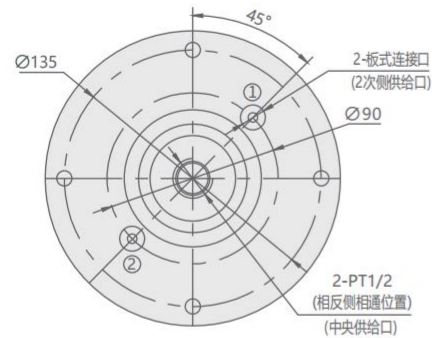

- ※1. 只有板式连接方式需要此项加工。
2. 安装面 (O型圈的密封面) 的表面粗糙度按6.3S加工。

※1. Only in the case of a gasket method, it is necessary  
2. Roughness of mounting surface (O-ring seal surface) should be 6.3s or less

## 订购标示法 ORDERING INDICATION

### CJRB-021SGS BGB

B S: 1次侧配管方式  
G : 2次侧配管方式  
B S: 中央供给口配管方式 (B:G螺纹 S:PT螺纹)

B S: Primary Side Piping Method  
G : Secondary Side Piping Method  
B S: Piping Method on Center Supply Port (B:G thread S: PT thread)

1. 旋转侧请使用螺栓固定法兰部, 停止侧请只对旋转方向进行固定。
2. 停止侧的配管请使用软管。
3. 油气并用时, 油膜有可能渗入气压回路, 请在两回路间设置残液排放回路。
4. 连续运转会导致内部密封件发热, 因此请避免连续运转。
5. 中央供给口用于冷却液供给时, 需要另行准备回转接头。
6. 各供给口均标有接口编号。

- 1.The rotation side must be fixed the flange part with of bolt, and restrain only the rotation direction of the stop side.
- 2.Please use hose for piping of stop side.
- 3.Please prepare one circuit for drainage between them when the oil slick leak from the hydraulic circuit to adjacent air circuit becomes a problem.
- 4.Please avoid continuous operation as it will cause overheating and damage to the internal packing.
- 5.When the central supply port is used for coolant supply, a rotary joint needs to be prepared separately.
- 6.Each port exhibits a port number.

1次侧供给口:	Incoming Port
2-PT1/4螺纹	2-PT1/4 Thread
2次侧供给口:	Outgoing Port
板式接口:	Gasket option
2-O型密封圈-1BP12(附带)	2-O-ring:1BP12(Included)
中央供给口:	Center supply port
2-PT1/2螺纹	2-PT1/2 Thread
附带4-M8×1.25×30螺栓	4-M8×1.25×30 thread included

### 安装部位加工尺寸 Machining Dimensions of Mounting Area

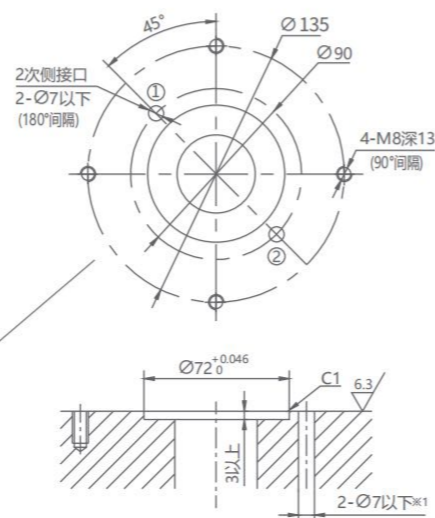

## 外形尺寸: CJRB-041

### External Dimensions: CJRB-041

※本图表示CJRB-041SGS(4回路+1中央供给口)

1次侧供给口或中央供给口需要G螺纹时, 请另行咨询。  
(中央供给口通过转换接头对应)

※This drawing indicates CJRB-041SGS(4 Port Circuit+1 Center supply port)  
When G thread is necessary for a primary port side or the center supply port, please contact us separately. (The central supply port is corresponding through a conversion joint.)

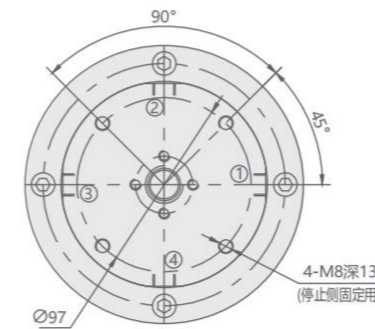
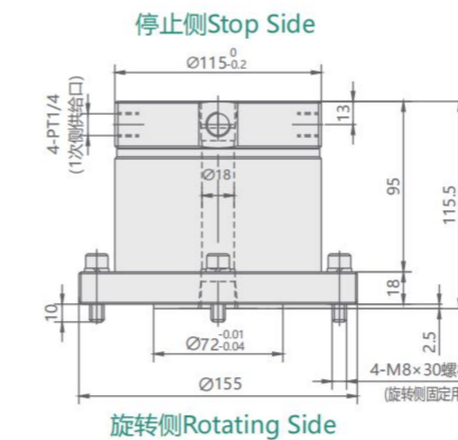
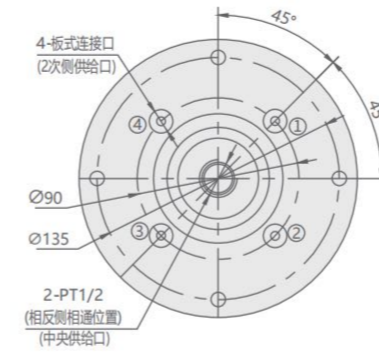

- ※1. 只有板式连接方式需要此项加工。
2. 安装面 (O型圈的密封面) 的表面粗糙度按6.3S加工。

※1. Only in the case of a gasket method, it is necessary  
2. Roughness of mounting surface (O-ring seal surface) should be 6.3s or less

## 订购标示法 ORDERING INDICATION

### CJRB-041SGS BGB

B S: 1次侧配管方式  
G : 2次侧配管方式  
B S: 中央供给口配管方式 (B:G螺纹 S:PT螺纹)

B S: Primary Side Piping Method  
G : Secondary Side Piping Method  
B S: Piping Method on Center Supply Port (B:G thread S: PT thread)

1. 旋转侧请使用螺栓固定法兰部, 停止侧请只对旋转方向进行固定。
2. 停止侧的配管请使用软管。
3. 油气并用时, 油膜有可能渗入气压回路, 请在两回路间设置残液排放回路。
4. 连续运转会导致内部密封件发热, 因此请避免连续运转。
5. 中央供给口用于冷却液供给时, 需要另行准备回转接头。
6. 各供给口均标有接口编号。

- 1.The rotation side must be fixed the flange part with of bolt, and restrain only the rotation direction of the stop side.
- 2.Please use hose for piping of stop side.
- 3.Please prepare one circuit for drainage between them when the oil slick leak from the hydraulic circuit to adjacent air circuit becomes a problem.
- 4.Please avoid continuous operation as it will cause overheating and damage to the internal packing.
- 5.When the central supply port is used for coolant supply, a rotary joint needs to be prepared separately.
- 6.Each port exhibits a port number.

1次侧供给口:	Incoming Port
4-PT1/4螺纹	4-PT1/4 Thread
2次侧供给口:	Outgoing Port
板式接口:	Gasket option
4-O型密封圈-1BP12(附带)	4-O-ring:1BP12(Included)
中央供给口:	Center supply port
2-PT1/2螺纹	2-PT1/2 Thread
附带4-M8×1.25×30螺栓	4-M8×1.25×30 thread included

### 安装部位加工尺寸 Machining Dimensions of Mounting Area

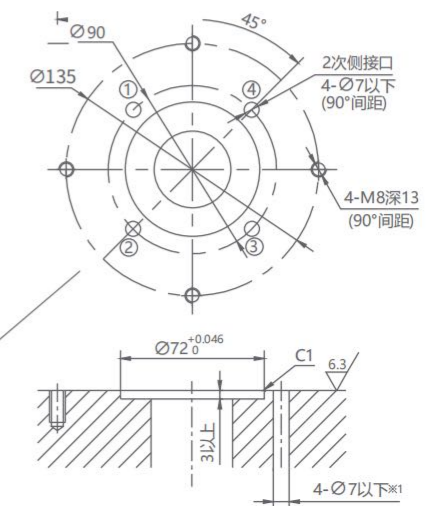

## 外形尺寸: CJRB-061

### External Dimensions: CJRB-061

※本图表示CJRB-061SGS(6回路+1中央供给口)

1次侧供给口或中央供给口需要G螺纹时, 请另行咨询。  
(中央供给口通过转换接头对应)

※This drawing indicates CJRB-061SGS(6 Port Circuit+1 Center supply port)  
When G thread is necessary for a primary port side or the center supply port, please contact us separately. (The central supply port is corresponding through a conversion joint.)

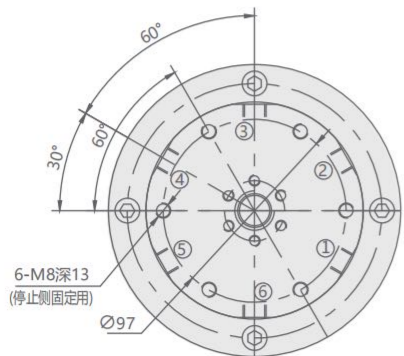
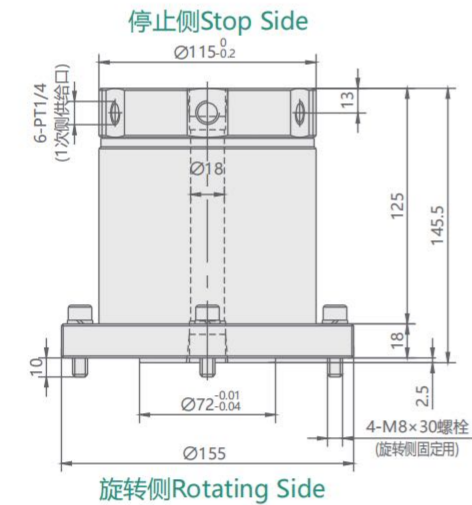
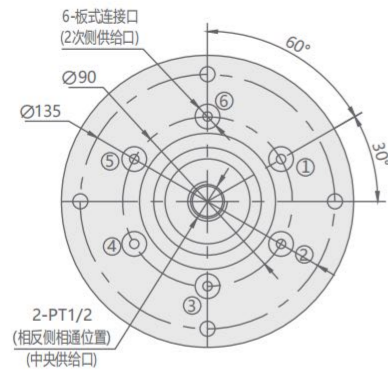

- ※1. 只有板式连接方式需要此项加工。
- 安装面 (O型圈的密封面) 的表面粗糙度按6.3S加工。

※1. Only in the case of a gasket method, it is necessary  
2. Roughness of mounting surface (O-ring seal surface) should be 6.3s or less

## 订购标示法 ORDERING INDICATION

### CJRB-061SGS BGB

B S: 1次侧配管方式  
G : 2次侧配管方式  
B S: 中央供给口配管方式 (B:G螺纹 S:PT螺纹)

B S: Primary Side Piping Method  
G : Secondary Side Piping Method  
B S: Piping Method on Center Supply Port (B:G thread S: PT thread)

1. 旋转侧请使用螺栓固定法兰部, 停止侧请只对旋转方向进行固定。
2. 停止侧的配管请使用软管。
3. 油气并用时, 油膜有可能渗入气压回路, 请在两回路间设置残液排放回路。
4. 连续运转会导致内部密封件发热, 因此请避免连续运转。
5. 中央供给口用于冷却液供给时, 需要另行准备回转接头。
6. 各供给口均标有接口编号。

1. The rotation side must be fixed the flange part with of bolt, and restrain only the rotation direction of the stop side.
2. Please use hose for piping of stop side.
3. Please prepare one circuit for drainage between them when the oil slick leak from the hydraulic circuit to adjacent air circuit becomes a problem.
4. Please avoid continuous operation as it will cause overheating and damage to the internal packing.
5. When the central supply port is used for coolant supply, a rotary joint needs to be prepared separately.
6. Each port exhibits a port number.

1次侧供给口:	Incoming Port
6-PT1/4螺纹	6-PT1/4 Thread
2次侧供给口:	Outgoing Port
板式连接口:	Gasket option
6-O型密封圈-1BP12(附带)	6-O-ring:1BP12(Included)
中央供给口:	Center supply port
2-PT1/2螺纹	2-PT1/2 Thread
附带4-M8×1.25×30螺栓	4-M8×1.25×30 thread included

### 安装部位加工尺寸 Machining Dimensions of Mounting Area

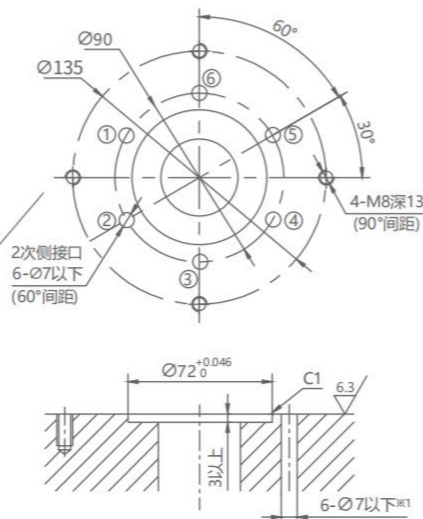

## 外形尺寸: CJRB-081

### External Dimensions: CJRB-081

※本图表示CJRB-081SGS(8回路+1中央供给口)

1次侧供给口或中央供给口需要G螺纹时, 请另行咨询。  
(中央供给口通过转换接头对应)

※This drawing indicates CJRB-081SGS(8 Port Circuit+1 Center supply port)  
When G thread is necessary for a primary port side or the center supply port, please contact us separately. (The central supply port is corresponding through a conversion joint.)

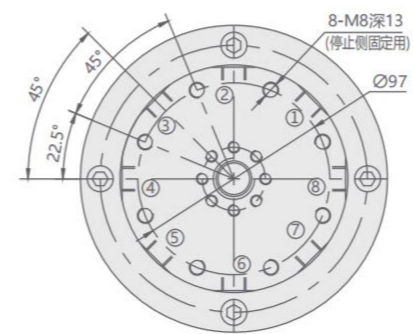
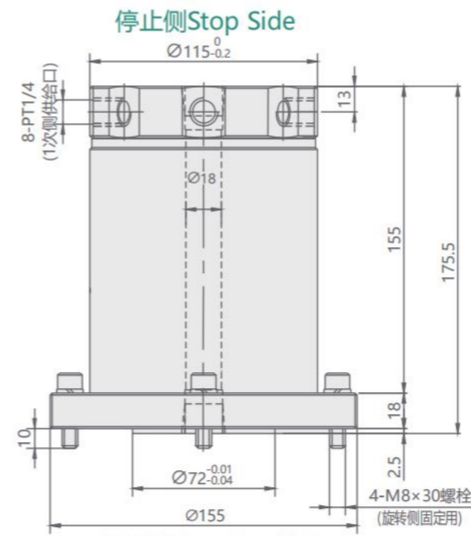
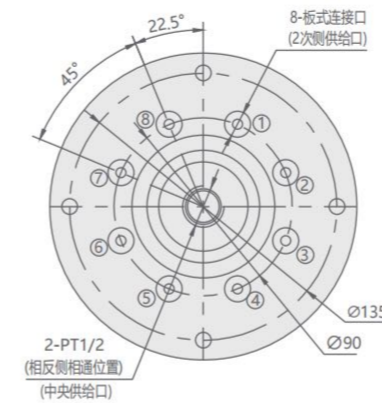

- ※1. 只有板式连接方式需要此项加工。
- 安装面 (O型圈的密封面) 的表面粗糙度按6.3S加工。

※1. Only in the case of a gasket method, it is necessary  
2. Roughness of mounting surface (O-ring seal surface) should be 6.3s or less

## 订购标示法 ORDERING INDICATION

### CJRB-081SGS BGB

B S: 1次侧配管方式  
G : 2次侧配管方式  
B S: 中央供给口配管方式 (B:G螺纹 S:PT螺纹)

B S: Primary Side Piping Method  
G : Secondary Side Piping Method  
B S: Piping Method on Center Supply Port (B:G thread S: PT thread)

1. 旋转侧请使用螺栓固定法兰部, 停止侧请只对旋转方向进行固定。
2. 停止侧的配管请使用软管。
3. 油气并用时, 油膜有可能渗入气压回路, 请在两回路间设置残液排放回路。
4. 连续运转会导致内部密封件发热, 因此请避免连续运转。
5. 中央供给口用于冷却液供给时, 需要另行准备回转接头。
6. 各供给口均标有接口编号。

1. The rotation side must be fixed the flange part with of bolt, and restrain only the rotation direction of the stop side.
2. Please use hose for piping of stop side.
3. Please prepare one circuit for drainage between them when the oil slick leak from the hydraulic circuit to adjacent air circuit becomes a problem.
4. Please avoid continuous operation as it will cause overheating and damage to the internal packing.
5. When the central supply port is used for coolant supply, a rotary joint needs to be prepared separately.
6. Each port exhibits a port number.

1次侧供给口:	Incoming Port
8-PT1/4螺纹	8-PT1/4 Thread
2次侧供给口:	Outgoing Port
板式连接口:	Gasket option
8-O型密封圈-1BP12(附带)	8-O-ring:1BP12(Included)
中央供给口:	Center supply port
2-PT1/2螺纹	2-PT1/2 Thread
附带4-M8×1.25×30螺栓	4-M8×1.25×30 thread included

### 安装部位加工尺寸 Machining Dimensions of Mounting Area

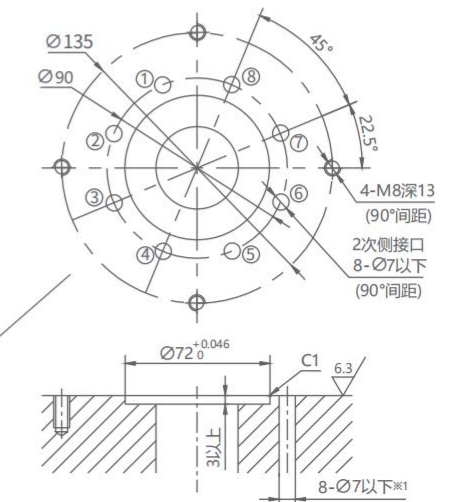

# CJRC

## 旋转接头

### CJRC ROTARY JOINT



#### 产品特性

旋转接头适用于油压/气压/的供给。  
采用专业开发的低摩擦密封件，从而实现了低转矩、顺畅的旋转动作。此接头是兼具了刚性/耐久性/密封性的嘉刚公司设计的长寿命旋转接头。供给口数量可选择2、4、6、8供给口。

#### 注意事项

- ※1.容许旋转速度是指在最高使用压力(油压7MPa)下的值。
- 1.油气并用时，油膜有可能渗入气压回路，请在两回路间设置残液排放回路。
- 2.连续运转会导致内部密封件发热，因此请避免连续运转。

#### 选配项 OPTIONS

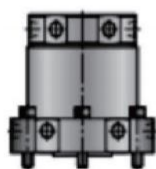

分类	供给口数量	特点	使用流体
CLASSIFICATION	THE NUMBER OF THE PORTS	FEATURES	USABLE FLUID
无中央供给口 No Center Through Port	2/4/6/8 供给口 Port	低转矩(紧凑型) Low Rotary Torque (Compact Design)	一般液压油: 7MPa以下 General Hydraulic Oil: 7 MPa or less 气压 1MPa以下 Air: 1MPa or Less

#### 订购标示法 ORDERING INDICATION

##### 示例: CJRC-020SA

CJRC	系列 Series	CJRC
02	供给口数量 The Number of the Ports	02: 2供给口2ports 04: 4供给口4ports 06: 6供给口6ports 08: 8供给口8ports
0	无中央供给口 Center Through Port	0: 无中心供给口 No Center Through Port
S	1次侧配管方式 Mounting Direction	B: 外配管式(G螺纹) Piping Option (BSPP Thread (G-Thread)) S: 外配管式(PT螺纹) Piping Option (BSPT (PT-Thread))
A	2次侧配管方式 Secondary Side Piping Method	A: 板式连接-外配管并用(附带PT螺纹堵头) A: Both Gasket and Piping Options (With BSPT Plug (PT-Thread Plug)) D: 板式连接-外配管并用(附带G螺纹堵头) D: Both Gasket and Piping Options (With BSPP (G-Thread Plug))

#### 注意事项 Note

- 1.如需要上接配管方式以外连接方式时，请另行咨询。
- 1.Please contact us if you need a piping option different than what is shown in model code of catalogue.

#### FEATURES

This product suitable for hydraulic and pneumatic supply. It adopts the original developed low friction seal and low torque enables smooth rotation. Each part of this rotary joint is highly durable and each seal provided by CLAMPTEK has low torque, highly durable and high capacity design that allows for a longer life of the component. You can select the number of ports from 2, 4, 6, 8 along with the center through port.

#### NOTE

- ※ 1. The allowable rotary speed is based on operating pressure of maximum 7MPa.
- 1. Please prepare one circuit for drainage between them when the oil slick leak from the hydraulic circuit to adjacent air circuit becomes a problem.
- 2. Please avoid continuous operation as it will cause overheating and damage to the internal packing.

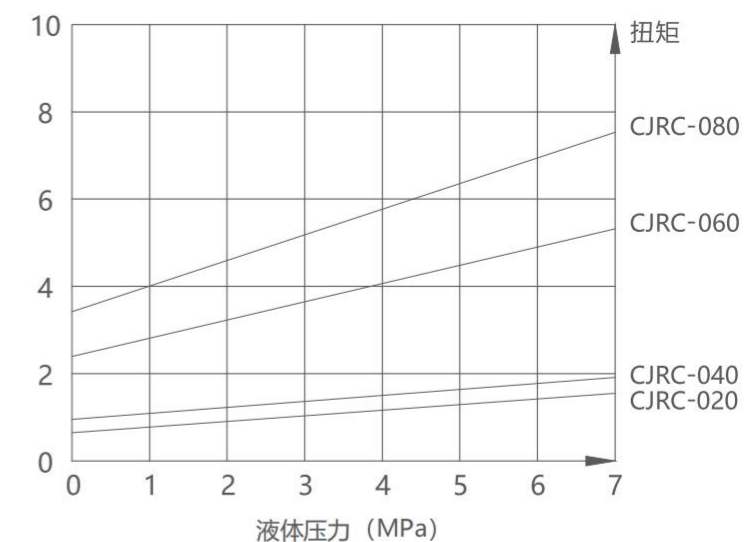

#### 能力曲线图(转矩:参考值)

PERFORMANCE CURVE  
(ROTARY TORQUE: REFERENCE VALUE)

型号 MODEL	转矩 ROTARY TORQUE (N·m)			
流体压力 FLUID PRESSURE (MPa)	CJRC-020	CJRC-040	CJRC-060	CJRC-080
7	1.5	1.8	5.5	7.5
6	1.4	1.7	5.1	6.9
5	1.4	1.6	4.7	6.4
4	1.3	1.5	4.3	5.8
3	1.2	1.5	4.0	5.3
2	1.1	1.4	3.6	4.7
1	1.1	1.3	3.2	4.2
0	1.0	1.2	2.8	3.6

#### 注意事项

- 1.本图表示转矩(N·m)与流体压力(MPa)之间的关系。
- 2.启动转矩偶尔会出现大于曲线图所示转矩2倍的情况。而且会因搁置时间等条件而发生变化。
- 3.转矩为参考值。

#### NOTE

- 1. This graph shows the relationship between the rotary torque and the fluid pressure.
- 2. The starting torque might be more than double of rotating torque shown in graphic and may change according to the conditions of the stationary down time. It varies according to the condition such as stationary down time.
- 3. The rotary torque is a reference value.

#### 规格参数表 SPECIFICATIONS

型号 MODEL	使用压力 OPERATING PRESSURE (MPa)		供给口 Ports		中央供给口 CENTER THROUGH PORT	容许旋转速度 (7MPa时)※1 ALLOWABLE ROTARY SPEED (AT 7MPa)※1(MIN-1)	重量 WEIGHT(kg)	使用温度 OPERATING TEMPERATURE(°C)	使用流体 USABLE FLUID
	油 OIL	空气 AIR	供给口数量 NUMBER	最小通路面积 MIN. PASSAGE AREA(mm²)					
CJRC-020	0~7.0	0~1.0	2	19.6	无Nothing	280	4.5	-10~70	普通液压油或空气 Recommended: ISO-VG-32 hydraulic oil equivalent to ISO viscosity grade or dry air
CJRC-040	0~7.0	0~1.0	4	19.6	无Nothing	280	5.5	-10~70	
CJRC-060	0~7.0	0~1.0	6	19.6	无Nothing	200	8.0	-10~70	
CJRC-080	0~7.0	0~1.0	8	19.6	无Nothing	200	8.6	-10~70	

外形尺寸: CJRC-020  
External Dimensions: CJRC-020

※本图表示CJRC-020SA(2回路)  
※This drawing indicates CJRC-020SA(2 Port Circuit)

1次侧供给口或2次侧供给口需要G螺纹时, 请另行咨询。  
When G thread is necessary for a primary side or secondary side port, please contact us separately.

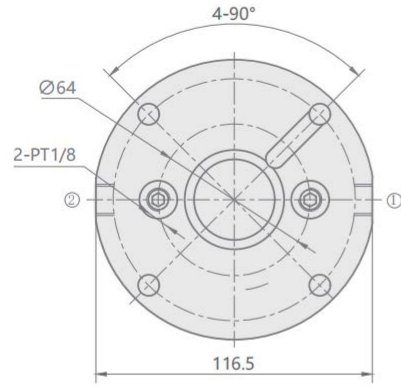

停止侧Stop Side

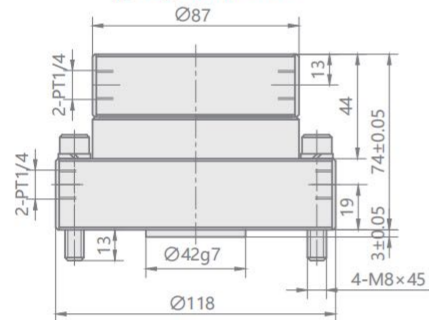

旋转侧Rotating Side

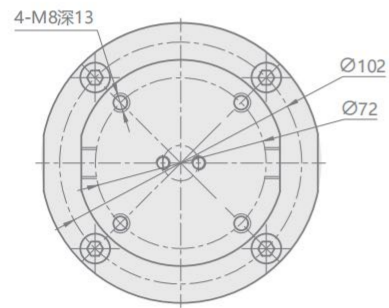

安装部位加工尺寸

Machining Dimensions of Mounting Area

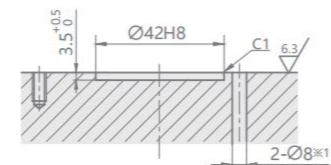
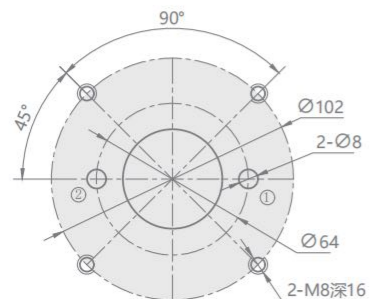

仅板式连接需要此项

订购标示法 ORDERING INDICATION  
CJRC-020BA  
SD

B S:1次侧配管方式 Primary Side Piping Method  
A D:2次侧配管方式 Secondary Side Piping Method

1. 旋转侧请使用螺栓固定法兰部, 停止侧请只对旋转方向进行固定。
2. 停止侧的配管请使用软管。
3. 油气并用时, 油膜有可能渗入气压回路, 请在两回路间设置残液排放回路。
4. 连续运转会导致内部密封件发热, 因此请避免连续运转。
5. 各供给口均标有及介面编号。
6. 2次侧使用PT1/4介面采用外配管方式连接时, 请使用附带的PT1/8螺纹堵头塞住板式连介面。当使用板式连介面时, 请安装O形密封圈和PT1/4螺纹堵头。

1. The rotation side must be fixed the flange part with of bolt, and restrain only the rotation direction of the stop side.
2. Please use hose for piping of stop side.
3. Please prepare one circuit for drainage between them when the oil slick leak from the hydraulic circuit to adjacent air circuit becomes a problem.
4. Please avoid continuous operation as it will cause overheating and damage to the internal packing.
5. Each port exhibits a port number.
6. When using PT1/4 thread for a secondary side port please attach the attached PT1/8 screw plug to the gasket port part. When using gasket option, please attach O-ring and PT1/4 plug.

1次侧供给口 Incoming Port  
2-PT1/4螺纹 2-PT1/4 Thread  
2次侧供给口 Outgoing Port  
2-PT1/4螺纹 2-PT1/4 Thread  
PT螺纹堵头(附带) With BSPT Plug (PT-Thread Plug)  
4-M8x45螺栓(附带)  
4-M8x1.25x45 Bolt (Included)

2-PT1/8螺纹 2-PT1/8 Thread  
R螺纹堵头(附带) With BSPT Plug (R-Thread Plug)  
2次侧供给口 Outgoing Port  
2-板式连介面 2-Gasket Port  
O形密封圈: 1BP12(附带)  
O-ring: 1BP12 (Included)

※1. 只有板式连接方式需要此项加工。  
2. 安装面(O形密封圈的密封面)的表面粗糙度按6.3S加工。

※1. Only in the case of a gasket method, it is necessary.  
2. Roughness of mounting surface (O-ring seal surface) should be 6.3S or less.

外形尺寸: CJRC-040  
External Dimensions: CJRC-040

※本图表示CJRC-040SA(4回路)  
※This drawing indicates CJRC-040SA(4 Port Circuit)

1次侧供给口或2次侧供给口需要G螺纹时, 请另行咨询。  
When G thread is necessary for a primary side or secondary side port, please contact us separately.

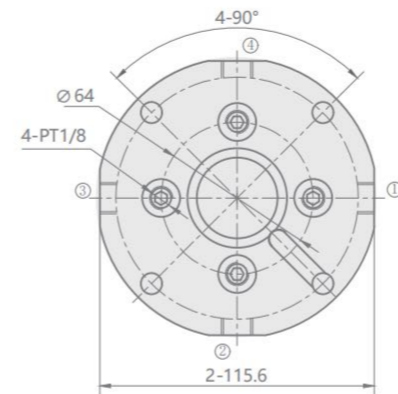

停止侧Stop Side

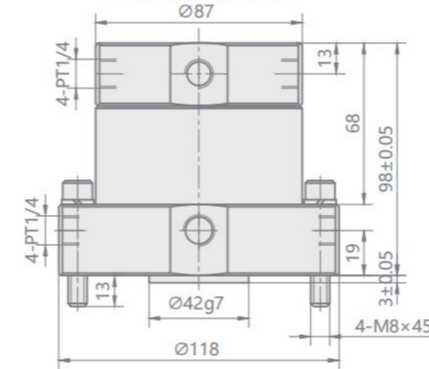

旋转侧Rotating Side

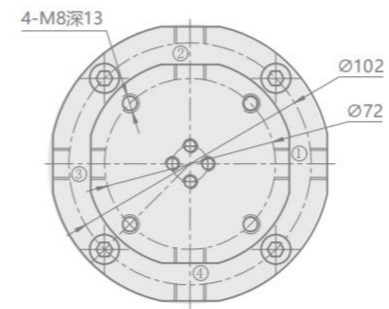

安装部位加工尺寸

Machining Dimensions of Mounting Area

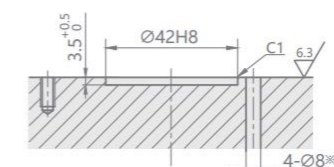
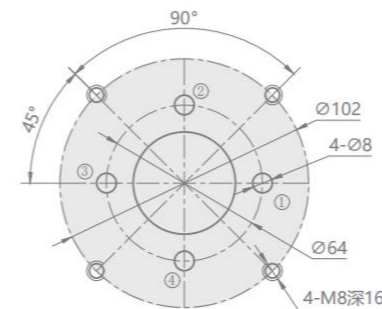

仅板式连接需要此项

订购标示法 ORDERING INDICATION  
CJRC-040BA  
SD

B S:1次侧配管方式 Primary Side Piping Method  
A D:2次侧配管方式 Secondary Side Piping Method

1. 旋转侧请使用螺栓固定法兰部, 停止侧请只对旋转方向进行固定。
2. 停止侧的配管请使用软管。
3. 油气并用时, 油膜有可能渗入气压回路, 请在两回路间设置残液排放回路。
4. 连续运转会导致内部密封件发热, 因此请避免连续运转。
5. 各供给口均标有及介面编号。
6. 2次侧使用PT1/4介面采用外配管方式连接时, 请使用附带的PT1/8螺纹堵头塞住板式连介面。当使用板式连介面时, 请安装O形密封圈和PT1/4螺纹堵头。

1. The rotation side must be fixed the flange part with of bolt, and restrain only the rotation direction of the stop side.
2. Please use hose for piping of stop side.
3. Please prepare one circuit for drainage between them when the oil slick leak from the hydraulic circuit to adjacent air circuit becomes a problem.
4. Please avoid continuous operation as it will cause overheating and damage to the internal packing
5. Each port exhibits a port number.
6. When using PT1/4 thread for a secondary side port, please attach the attached PT1/8 screw plug to the gasket port part. When using gasket option, please attach O-ring and PT1/4 plug.

1次侧供给口 Incoming Port  
4-PT1/4螺纹 4-PT1/4 Thread  
2次侧供给口 Outgoing Port  
4-PT1/4螺纹 4-PT1/4 Thread  
PT螺纹堵头(附带) With BSPT Plug (PT-Thread Plug)  
4-M8x45螺栓(附带)  
4-M8x1.25x45 Bolt (Included)

4-PT1/8螺纹 4-PT1/8 Thread  
PT螺纹堵头(附带) With BSPT Plug (PT-Thread Plug)  
2次侧供给口 Outgoing Port  
2-板式连介面 2-Gasket Port  
O形密封圈: 1BP12(附带)  
O-ring: 1BP12 (Included)

※1. 只有板式连接方式需要此项加工。  
2. 安装面(O形密封圈的密封面)的表面粗糙度按6.3S加工。

※1. Only in the case of a gasket method, it is necessary.  
2. Roughness of mounting surface (O-ring seal surface) should be 6.3S or less.

外形尺寸: CJRC-060  
External Dimensions: CJRC-060

※本图表示CJRC-060SA(6回路)  
□This drawing indicates CJRC-060SA(6 Port Circuit)

1次侧供给口或2次侧供给口需要G螺纹时, 请另行咨询。  
When G thread is necessary for a primary side or secondary side port, please contact us separately.

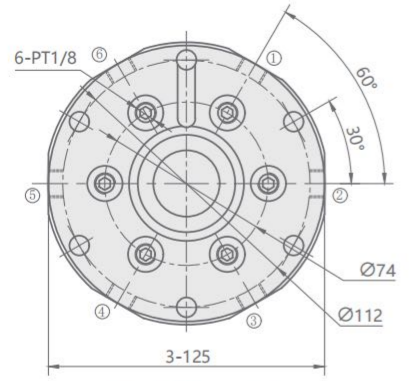

停止侧Stop Side

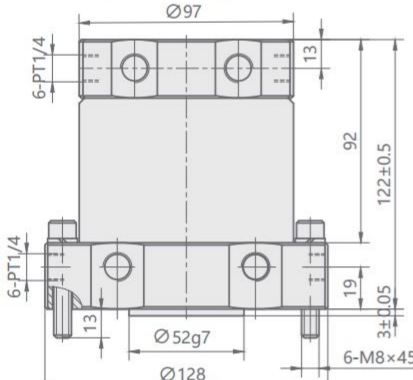

旋转侧Rotating Side

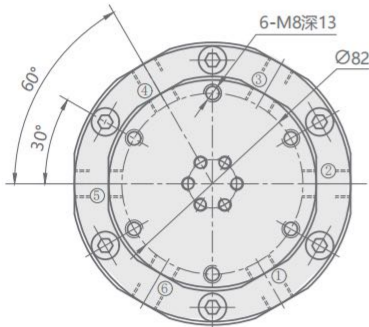

安装部位加工尺寸

Machining Dimensions of Mounting Area

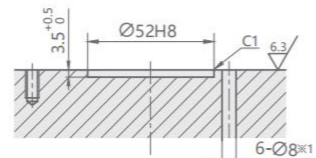
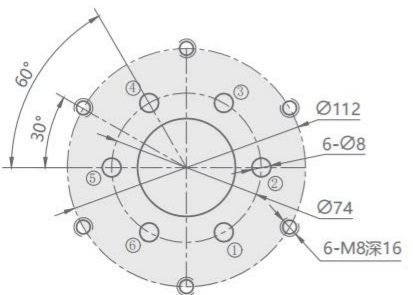

仅板式连接需要此项

订购标示法 ORDERING INDICATION  
CJRC-060BA  
SD

B S:1次侧配管方式 Primary Side Piping Method  
A D:2次侧配管方式 Secondary Side Piping Method

1. 旋转侧请使用螺栓固定法兰部, 停止侧请只对旋转方向进行固定。
2. 停止侧的配管请使用软管。
3. 油气并用时, 油膜有可能渗入气压回路, 请在两回路间设置残液排放回路。
4. 连续运转会导致内部密封件发热, 因此请避免连续运转。
5. 各供给口均标有及介面编号。
6. 2次侧使用PT1/4介面采用外配管方式连接时, 请使用附带的PT1/8螺纹堵头塞住板式连介面。当使用板式连介面时, 请安装O形密封圈和PT1/4螺纹堵头。

1. The rotation side must be fixed the flange part with of bolt, and restrain only the rotation direction of the stop side.
2. Please use hose for piping of stop side.
3. Please prepare one circuit for drainage between them when the oil slick leak from the hydraulic circuit to adjacent air circuit becomes a problem.
4. Please avoid continuous operation as it will cause overheating and damage to the internal packing
5. Each port exhibits a port number.
6. When using PT1/4 thread for a secondary side port, please attach the attached PT1/8 screw plug to the gasket port part. When using gasket option, please attach O-ring and PT1/4 plug.

- 1次侧供给口 Incoming Port  
6-PT1/4螺纹 6-PT1/4 Thread  
2次侧供给口 Outgoing Port  
6-PT1/4螺纹 6-PT1/4 Thread  
PT螺纹堵头(附带) With BSPT Plug (PT-Thread Plug)  
4-M8×45 螺栓(附带)  
4-M8×1.25×45 Bolt (Included)

- 6-PT1/8螺纹 6-PT1/8 Thread  
PT螺纹堵头(附带) With BSPT Plug (PT-Thread Plug)  
2次侧供给口 Outgoing Port  
2-板式连介面 2-Gasket Port  
O形密封圈: 1BP12(附带)  
O-ring: 1BP12 (Included)

※1. 只有板式连接方式需要此项加工。  
2. 安装面(O形密封圈的密封面)的表面粗糙度按6.3S加工。

- ※1. Only in the case of a gasket method. it is necessary.  
1. Roughness of mounting surface (O-ring seal surface) should be 6.3S or less.

外形尺寸: CJRC-080  
External Dimensions: CJRC-080

※本图表示CJRC-080SA(8回路)  
□This drawing indicates CJRC-080SA(8 Port Circuit)

1次侧供给口或2次侧供给口需要G螺纹时, 请另行咨询。  
When G thread is necessary for a primary side or secondary side port, please contact us separately.

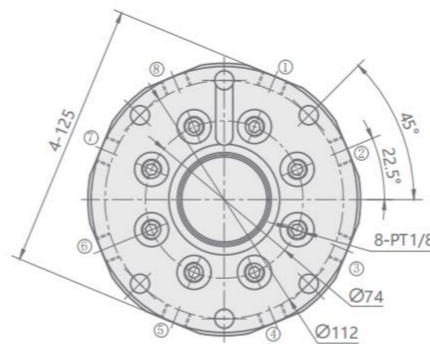

停止侧Stop Side

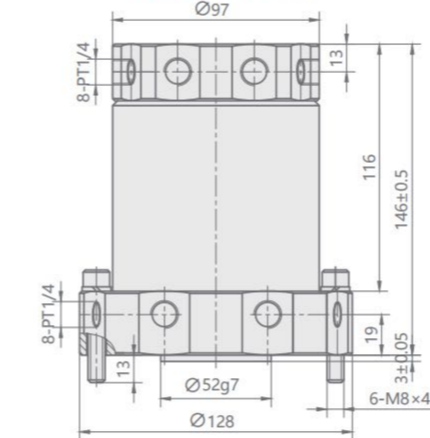

旋转侧Rotating Side

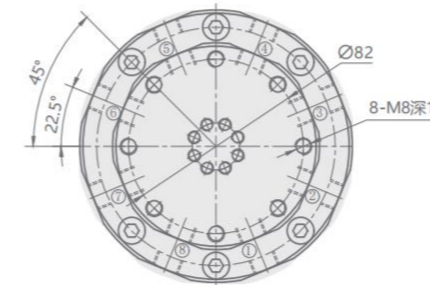

安装部位加工尺寸

Machining Dimensions of Mounting Area

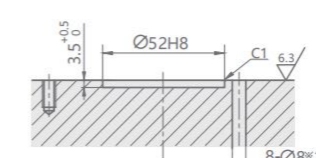
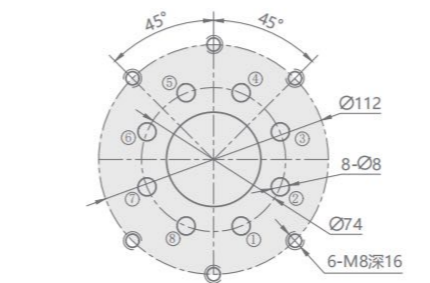

仅板式连接需要此项

订购标示法 ORDERING INDICATION  
CJRC-080BA  
SD

B S:1次侧配管方式 Primary Side Piping Method  
A D:2次侧配管方式 Secondary Side Piping Method

1. 旋转侧请使用螺栓固定法兰部, 停止侧请只对旋转方向进行固定。
2. 停止侧的配管请使用软管。
3. 油气并用时, 油膜有可能渗入气压回路, 请在两回路间设置残液排放回路。
4. 连续运转会导致内部密封件发热, 因此请避免连续运转。
5. 各供给口均标有及介面编号。
6. 2次侧使用PT1/4介面采用外配管方式连接时, 请使用附带的PT1/8螺纹堵头塞住板式连介面。当使用板式连介面时, 请安装O形密封圈和PT1/4螺纹堵头。

1. The rotation side must be fixed the flange part with of bolt, and restrain only the rotation direction of the stop side.
2. Please use hose for piping of stop side.
3. Please prepare one circuit for drainage between them when the oil slick leak from the hydraulic circuit to adjacent air circuit becomes a problem.
4. Please avoid continuous operation as it will cause overheating and damage to the internal packing
5. Each port exhibits a port number.
6. When using PT1/4 thread for a secondary side port, please attach the attached PT1/8 screw plug to the gasket port part. When using gasket option, please attach O-ring and PT1/4 plug.

- 1次侧供给口 Incoming Port  
8-PT1/4螺纹 8-PT1/4 Thread  
2次侧供给口 Outgoing Port  
8-PT1/4螺纹 8-PT1/4 Thread  
PT螺纹堵头(附带) With BSPT Plug (PT-Thread Plug)  
4-M8×45 螺栓(附带)  
4-M8×1.25×45 Bolt (Included)

- 8-PT1/8螺纹 8-PT1/8 Thread  
PT螺纹堵头(附带) With BSPT Plug (PT-Thread Plug)  
2次侧供给口 Outgoing Port  
2-板式连介面 2-Gasket Port  
O形密封圈: 1BP12(附带)  
O-ring: 1BP12 (Included)

※1. 只有板式连接方式需要此项加工。  
2. 安装面(O形密封圈的密封面)的表面粗糙度按6.3S加工。

- ※1. Only in the case of a gasket method. it is necessary.  
1. Roughness of mounting surface (O-ring seal surface) should be 6.3S or less.

# CJRD

## 旋转接头

### CJRD ROTARY JOINT



#### 产品特性

旋转接头适用于液压、气压、大容量冷却液的供给。采用专业开发的低摩擦密封件，从而实现了低转矩，顺畅的旋转动作。此接头是兼具了刚性、耐久性、密封性的嘉刚公司设计的长寿命旋转接头，供给口数量可选择12、16供给口。

#### 注意事项

1. 油气并用时，油膜有可能渗入气压回路，请在两回路间设置排油口。
2. 连续运转会导致内部密封件发热，因此请避免连续运转。

#### 选配项 OPTIONS

分类 CLASSIFICATION	供给口数量 THE NUMBER OF THE PORTS	特点 FEATURES	使用流体 USABLE FLUID
无中央供给口 No Center Through Port	12/16供给口 Port	低转矩(紧凑型) Low Rotary Torque (Compact Design)	一般液压油: 25MPa以下 General Hydraulic Oil: 25 MPa or less 气压: 1MPa以下 Air: 1MPa or Less

#### 订购标示法 ORDERING INDICATION

示例: CJRD-120SG

CJRD	系列	CJRD
12	供给口数量 The Number of the Ports	12: 12供给口 16: 16供给口 12 ports 16 ports
0	无中央供给口 Center Through Port	0: 无中央供给口 0 Center Through Port
S	1次侧配管方式 Mounting Direction	B: 外配管式 (G螺纹) Piping Option (G-Thread) S: 外配管式 (PT螺纹) Piping Option (PT-Thread)
G	2次侧配管方式 Mounting Direction	G: 板式连接型 (附带O环密封圈) G: Gasket option (O-ring included)

#### 注意事项

如需要上記配管方式以外的连接方式时，请另行咨询。

#### FEATURES

This product suitable for hydraulic & pneumatic and large-capacity cooling liquid supply. It adopts the original developed low friction seal and low torque enables smooth rotation. Each part of this rotary joint is highly durable and each seal provided by CLAMPTEK has low torque, highly durable and high capacity design that allows for a longer life of the component. You can select the number of ports from 12,16 along with the center through port.

#### NOTE

1. Please prepare one circuit for drainage between them when the oil slick leak from the hydraulic circuit to adjacent air circuit becomes a problem.
2. Please avoid continuous operation as it will cause overheating and damage to the internal packing.

#### NOTE

Please contact us if you need a piping option different than what is shown in model code of catalogue.

型号	转矩(N·m)	
	CJRD-120 □G	CJRD-160 □G
25	100.0	145.0
20	75.0	114.0
15	56.0	89.0
10	42.5	70.0
7	35.0	59.0
0	20.0	40.0

#### 注意事项

1. 本图表示转矩(N·m)与流体压力(MPa)之间的关系。
2. 启动转矩偶尔会出现大于曲线图所示转矩2倍的情况，而且会因搁置时间等条件而发生变化。
3. 转矩仅为参考值。

型号	容许转速(min <sup>-1</sup> )	
流体压力(MPa)	CJRD-120 □G	CJRD-160 □G
25	25	20
14	55	48
7	90	80
2.5	135	120

#### 注意事项

1. 本图表示容许旋转速度(min<sup>-1</sup>)与流体压力(MPa)之间的关系。
2. 即使在容许旋转速度以下，如果使用温度超出规格值时也是不可使用的。
3. 转速仅为参考值。

#### 规格参数表 SPECIFICATIONS

型号	使用压力(MPa) OPERATING PRESSURE (MPa)	供给口 PORTS	中央供给口	重量	使用温度	使用流体	
MODEL	油OIL 空气AIR	供给口数量 NUMBER	最小通路面积mm <sup>2</sup> MIN. PASSAGE AREA(mm <sup>2</sup> )	CENTER THROUGH PORT	WEIGHT (kg)	OPERATING TEMPERATURE(°C)	USABLE FLUID
CJRD-120□G	0~25.0 0~1.0	12	9.1	无Nothing	20	-10~70	普通液压油或空气 Recommended: ISO-VG-32 hydraulic oil equivalent to ISO viscosity grade or dry air
CJRD-160□G	0~25.0 0~1.0	16	9.1	无Nothing	25	-10~70	

能力曲线图 (转矩: 参考值)

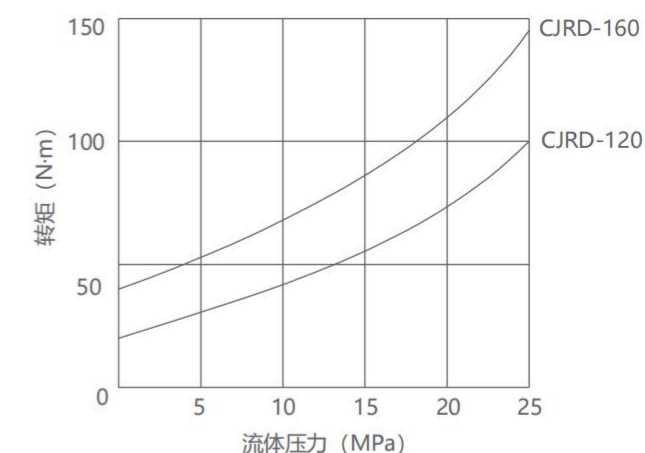

#### NOTE

1. This graph shows the relationship between torque (N·m) and fluid pressure (MPa).
2. The starting torque might be more than double of rotating torque shown in graphic and may change according to the conditions of the stationary down time. It varies according to the condition such as stationary down time.
3. The torque is only a reference value.

能力曲线图 (转速: 参考值)

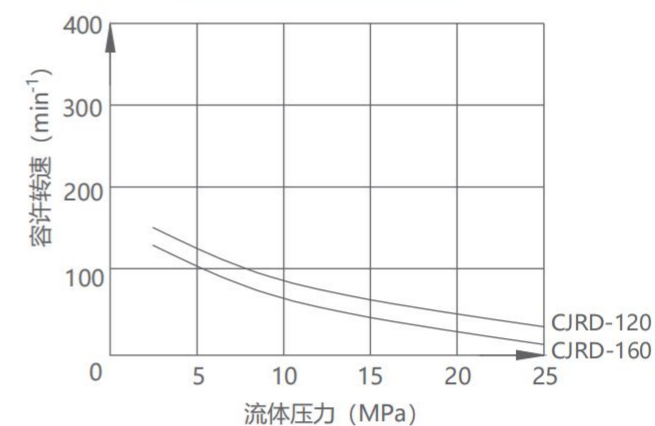

#### NOTE

1. This graph shows the relationship between the allowable rotational speed (min<sup>-1</sup>) and the fluid pressure (MPa).
2. Even below the allowable rotational speed, it cannot be used if the operating temperature exceeds the specified value.
3. The rotational speed is only a reference value.

## 外形尺寸: CJRD-120

### External Dimensions: CJRD-120

※本图表示CJRD-120SG(12回路)  
1次侧供给口需要G螺纹时, 请另行咨询。

※This drawing indicates CJRD-120SG(12 Port Circuit)  
When G thread is necessary for a primary port side, please contact us separately.

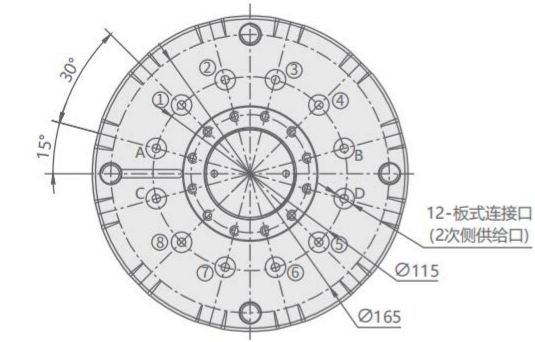

#### 停止侧Stop Side

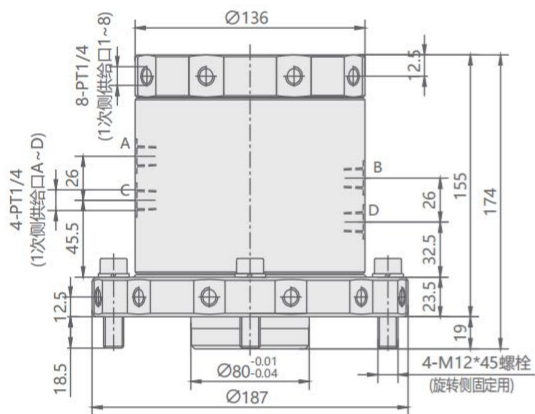

#### 旋转侧Rotating Side

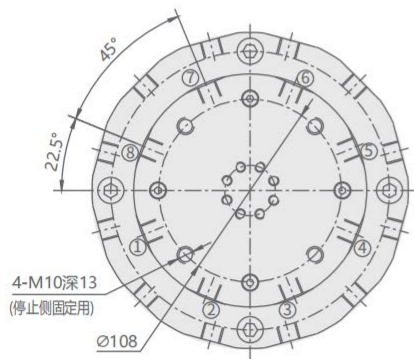

1. 安装面 (O型圈的密封面) 的表面粗糙度按6.3S加工。

1. Roughness of mounting surface (O-ring seal surface) should be 6.3s or less

## 订购标示法 ORDERING INDICATION

### CJRD-120SG B

B S: 1次侧配管方式  
G: 2次侧配管方式 (B:G螺纹 S:PT螺纹)

B S: Primary Side Piping Method  
G: Secondary Side Piping Method (B: G thread S: PT thread)

1. 旋转侧请使用螺栓固定法兰部, 停止侧请只对旋转方向进行固定。
2. 停止侧的配管请使用软管。
3. 油气并用时, 请将1~8用于油, A~D用于气。此型号旋转接头采用了双重结构, 将1~8的旋转密封直径设计的比A~D直径小。由于油压造成的密封件的阻力变小, 有效降低了旋转力矩。有效解决了从油压回路渗到气压回路的油膜问题。
4. 连续运转会导致内部密封件发热, 因此请避免连续运转。
5. 各供给口均标有接口编号。

1. The rotation side must be fixed the flange part with of bolt, and restrain only the rotation direction of the stop side.
2. Please use hose for piping of stop side.
3. When oil and air are used simultaneously, please use 1 to 8 for oil and A to D for air. This model of rotary joint adopts a dual structure, with the rotary seal diameters of 1 to 8 designed to be smaller than those of A to D.

The resistance of the seal caused by oil pressure is reduced, effectively lowering the rotational torque. It effectively solved the problem of oil film seeping from the hydraulic circuit to the pneumatic circuit.

4. Please avoid continuous operation as it will cause overheating and damage to the internal packing.
5. Each port exhibits a port number.

1次侧供给口: Incoming Port  
8-PT1/4螺纹(1~8) 8-PT1/4 Thread(1~8)  
4-PT1/4螺纹(A~D) 4-PT1/4 Thread(1~4)

2次侧供给口: Outgoing Port  
板式接口: Gasket option  
12-O型密封圈-1BP12(附带) 12-O-ring:1BP12(Included)  
附带4-M12×1.25×45螺栓 4-M12×1.25×45 thread included

#### 安装部位加工尺寸 Machining Dimensions of Mounting Area

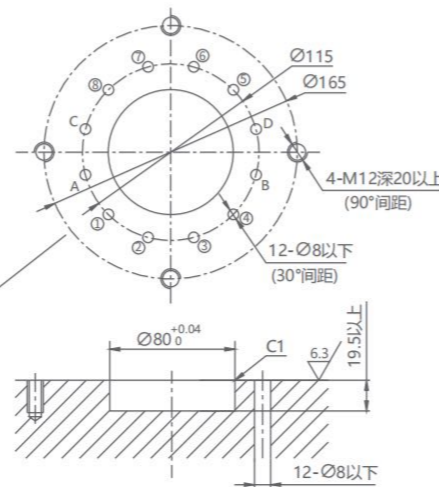

## 外形尺寸: CJRD-160

### External Dimensions: CJRD-160

※本图表示CJRD-160SG(16回路)

1次侧供给口需要G螺纹时, 请另行咨询。

※This drawing indicates CJRD-160SG(16 Port Circuit)  
When G thread is necessary for a primary port side, please contact us separately.

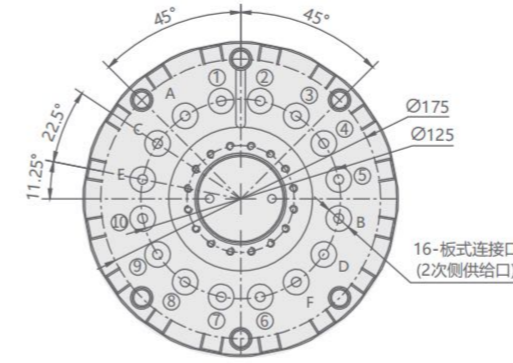

#### 停止侧Stop Side

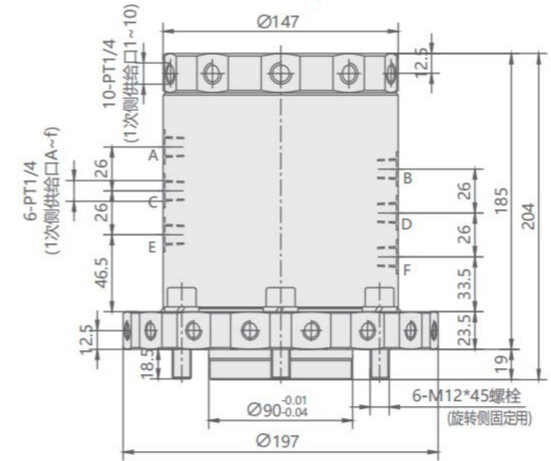

#### 旋转侧Rotating Side

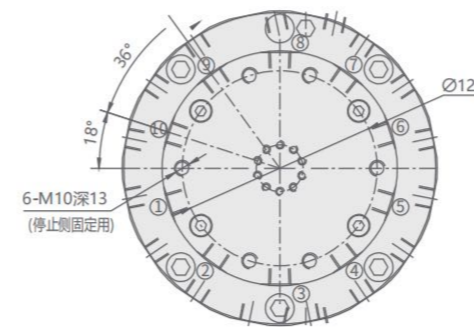

1. 安装面 (O型圈的密封面) 的表面粗糙度按6.3S加工。

1. Roughness of mounting surface (O-ring seal surface) should be 6.3s or less

## 订购标示法 ORDERING INDICATION

### CJRD-160SG B

B S: 1次侧配管方式  
G: 2次侧配管方式 (B:G螺纹 S:PT螺纹)

B S: Primary Side Piping Method  
G: Secondary Side Piping Method (B: G thread S: PT thread)

1. 旋转侧请使用螺栓固定法兰部, 停止侧请只对旋转方向进行固定。
2. 停止侧的配管请使用软管。
3. 油气并用时, 请将1~10用于油, A~F用于气。此型号旋转接头采用了双重结构, 将1~10的旋转密封直径设计的比A~F直径小。由于油压造成的密封件的阻力变小, 有效降低了旋转力矩。有效解决了从油压回路渗到气压回路的油膜问题。
4. 连续运转会导致内部密封件发热, 因此请避免连续运转。
5. 各供给口均标有接口编号。

1. The rotation side must be fixed the flange part with of bolt, and restrain only the rotation direction of the stop side.
2. Please use hose for piping of stop side.
3. When oil and air are used simultaneously, please use 1 to 10 for oil and A to F for air. This model of rotary joint adopts a dual structure, with the rotary seal diameters of 1 to 10 designed to be smaller than those of A to F.

The resistance of the seal caused by oil pressure is reduced, effectively lowering the rotational torque. It effectively solved the problem of oil film seeping from the hydraulic circuit to the pneumatic circuit.

4. Please avoid continuous operation as it will cause overheating and damage to the internal packing.
5. Each port exhibits a port number.

1次侧供给口: Incoming Port  
10-PT1/4螺纹(1~8) 10-PT1/4 Thread(1~8)  
6-PT1/4螺纹(A~D) 6-PT1/4 Thread(A~D)  
2次侧供给口: Outgoing Port  
板式接口: Gasket option  
16-O型密封圈-1BP12(附带) 16-O-ring:1BP12(Included)  
附带6-M12×1.25×45螺栓 6-M12×1.25×45 thread included

#### 安装部位加工尺寸 Machining Dimensions of Mounting Area

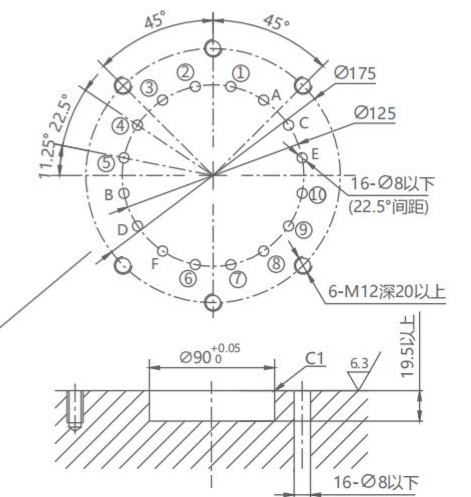

# CRA

## 油路旋转接头

### CRA HYDRAULIC ROTARY JOINT



#### 产品特性

根据国内机加客户的不断提升, 对四轴夹具的要求也越来越多, 我们对客户的反馈信息进行了筛选, 为客户量身设计了这款CRA旋转接头, 欢迎大家选购。如您在选型时有任何疑问, 请随时与我司技术人员联系。感谢您的支持!

#### FEATURES

According to the continuous improvement of domestic machining customers, there are more and more requirements for four-axis fixtures. We have screened the feedback information of customers and customized the CRA rotary joint for customers. Welcome to buy. If you have any questions about the model selection, please feel free to contact our technician. Thank you for your support!

#### 注意事项

- 1.油气并用时, 油膜有可能渗入气压回路, 请在两回路间设残液排放回路。
- 2.连续运转会导致内部密封件发热, 因此请避免连续运转。

#### NOTE

- 1.Please prepare one circuit for drainage between them when the oil slick leak from the hydraulic circuit to adjacent air circuit becomes a problem.
- 2.Please avoid continuous operation as it will cause overheating and damage to the internal packing.

#### 规格参数表 SPECIFICATIONS

型号	CRA/CRB/CRC-2	CRA/CRB/CRC-4	CRA/CRB/CRC-6
回路数	2回路	4回路	6回路
使用流体	相当于ISO黏度等级ISO-VG-32一般液压油		
最高使用压力(MPa)	25		
允许转速	因流体压力而异		
使用环境温度(°C)	0~70		
配管介面尺寸	PT1/8		
质量(kg)	255	3.18	3.80
	320	3.57	4.37
	400	3.76	4.76

#### 订购标示法 ORDERING INDICATION

示例: CRA-2-255

型式	回路数	四轴型号
CRA:旋转接头	2	255/320/400
CRB:配油器	4	
CRC:连接轴	6	320/400

### CRA/CRB/CRC-2

#### CRA-2

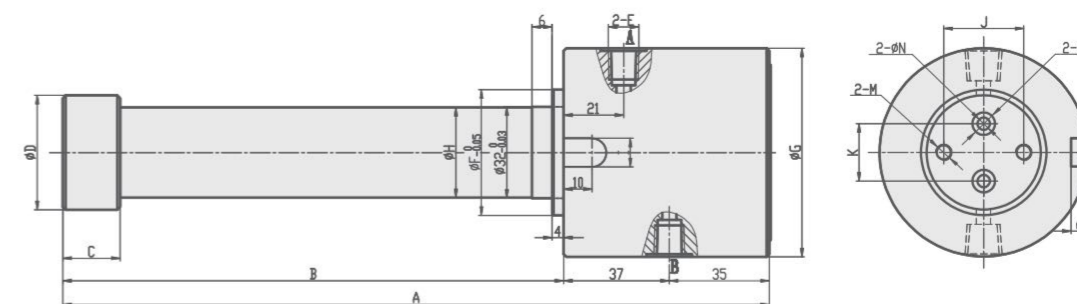

#### CRB-2

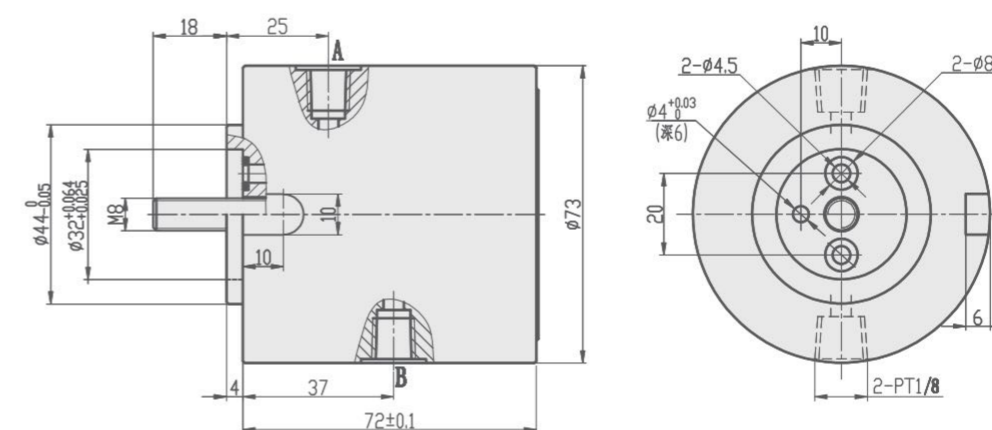

#### CRC-2

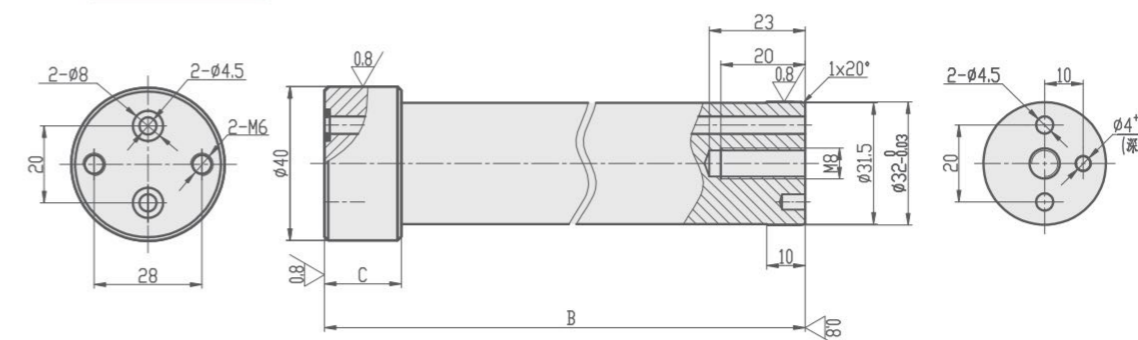

Unit:mm

型号 Model	A	B	C	D	E	F	G	H	I	J	K	L	M	N
CRA/CRC-2-255	247	175	20	40	PT1/8	44	73	31.5	10	28	20	8.0	M6	4.5
CRA/CRC-2-320	317	245	20	40	PT1/8	44	73	31.5	10	28	20	8.0	M6	4.5
CRA/CRC-2-400	362	290	20	40	PT1/8	44	73	31.5	10	28	20	8.0	M6	4.5

### CRA/CRB/CRC-4

CRA-4

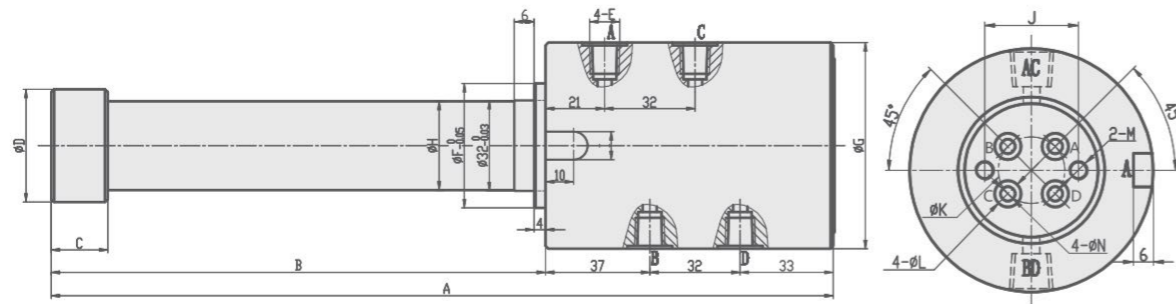

CRB-4

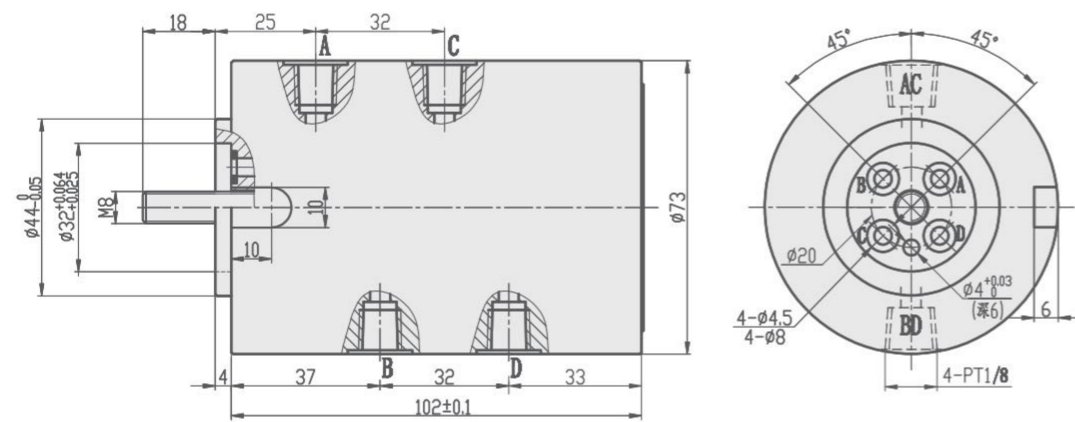

CRC-4

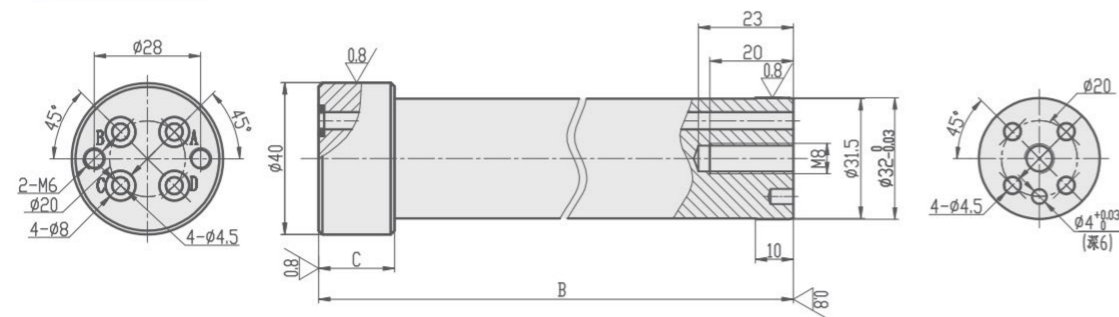

Unit:mm

型号 Model	A	B	C	D	E	F	G	H	I	J	K	L	M	N
CRA/CRC-4-255	277	175	20	40	PT1/8	44	73	31.5	10	28	20	8.0	M6	4.5
CRA/CRC-4-320	347	245	20	40	PT1/8	44	73	31.5	10	28	20	8.0	M6	4.5
CRA/CRC-4-400	392	290	20	40	PT1/8	44	73	31.5	10	28	20	8.0	M6	4.5

### CRA/CRB/CRC-6

CRA-6

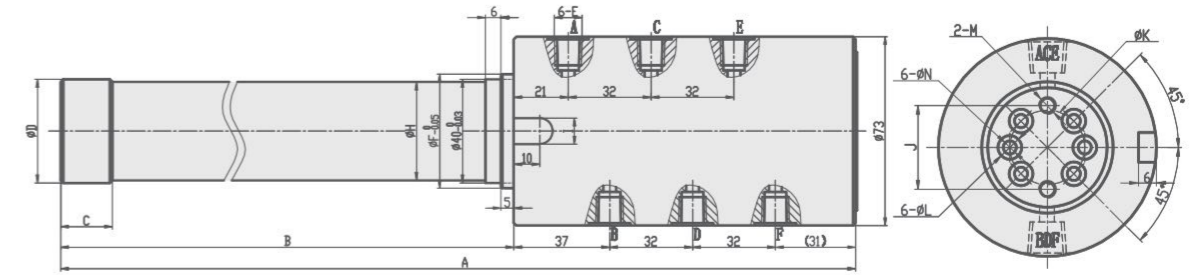

CRB-6

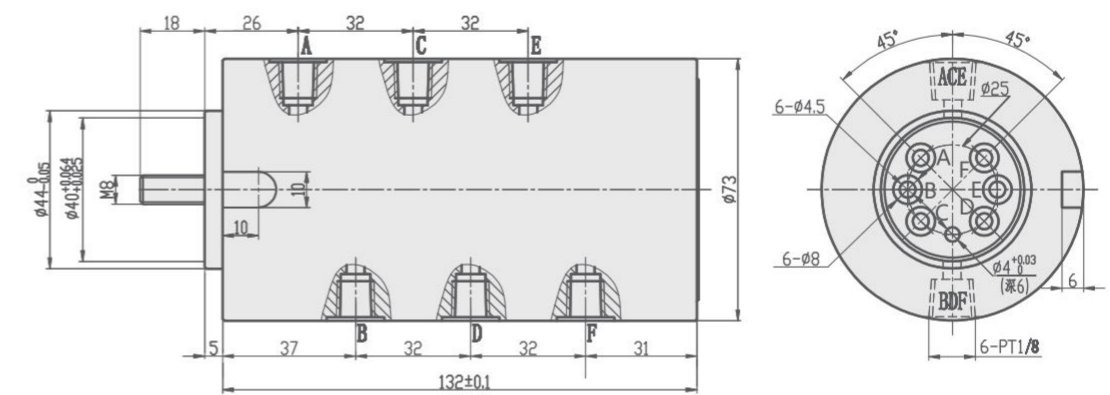

CRC-6

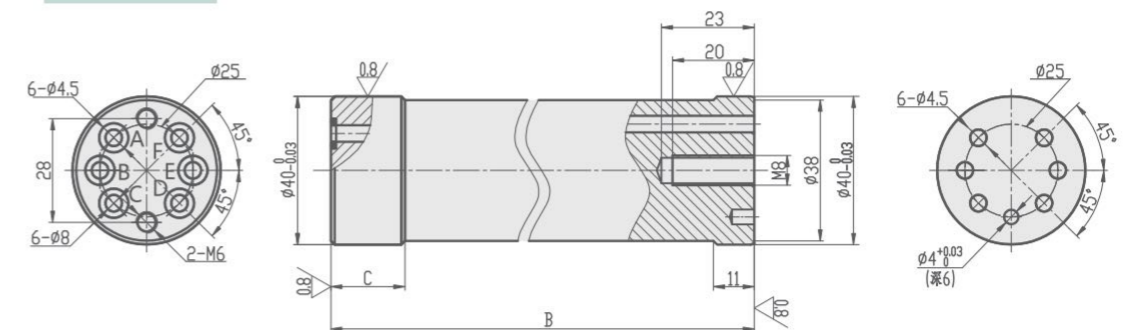

Unit:mm

型号 Model	A	B	C	D	E	F	G	H	I	J	K	L	M	N
CRA/CRC-6-320	377	245	20	40	PT1/8	44	73	38	10	28	25	8.0	M6	4.5
CRA/CRC-6-400	422	290	20	40	PT1/8	44	73	38	10	28	25	8.0	M6	4.5



# CRA-HS

快速旋转接头

## CRA-HS QUICK ROTARY JOINT



### 快速旋转接头尺寸

#### 订购标示法 ORDERING INDICATION

示例: CRA-HS-02P

CRA	系列 Series	CRA
HS	形式 Type	快速(3000rpm)
02	供油口 Port	02 04
P	精度等级 Precision	空白: 标准 Blank: Standard P: 高精度 P: High precision

#### 规格参数表 SPECIFICATIONS

型号 MODEL	CRA-HS-02	CRA-HS-02P	CRA-HS-04	CRA-HS-04P
精度等级 PRECISION	标准 Standard	高精度 High precision	标准 Standard	高精度 High precision
使用压力 PRESSURE (MPa)	油压	2.5 ~ 7.0		
	气压	0.2 ~ 1.0		
供给口 PORT	数量	2	4	
最小转动扭矩(在7MPa时) MINIMUM ROTATIONAL TORQUE (AT 7MPa) N*M		3	5	
泄漏量(在7MPa时) LEAKAGE (AT 7MPa) ml/min	≤80	≤30	≤200	≤50
额定转速(在7MPa时) RATED SPEED (AT 7MPa) rpm	3000			
使用温度范围 RANGE OF TEMPERATURE(°C)	0 ~ 70			
使用流体 USABLE FLUID	ISO-VG32 一般液压油 ISO-VG-32 hydraulic oil equivalent to ISO viscosity grade			

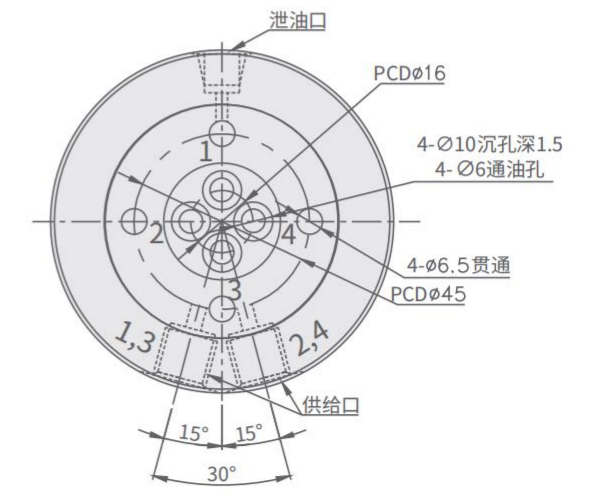
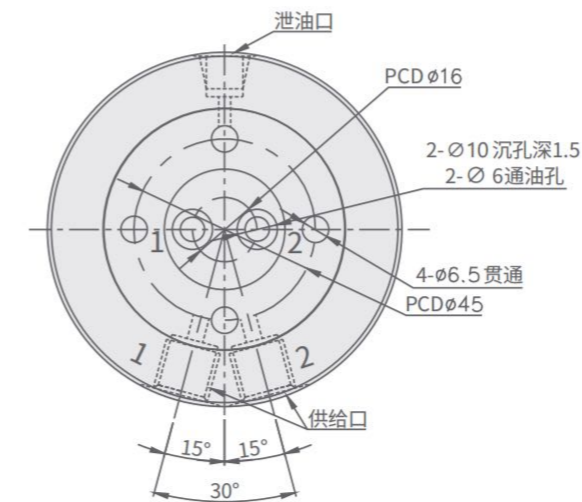
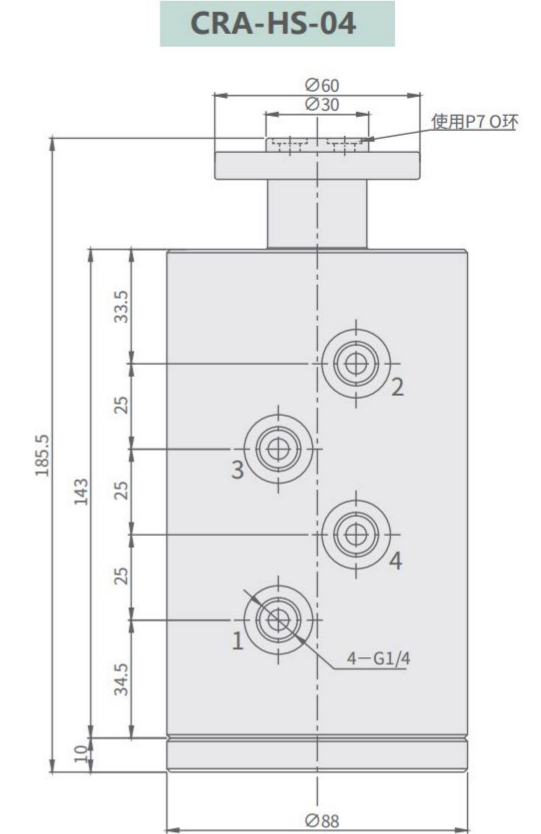
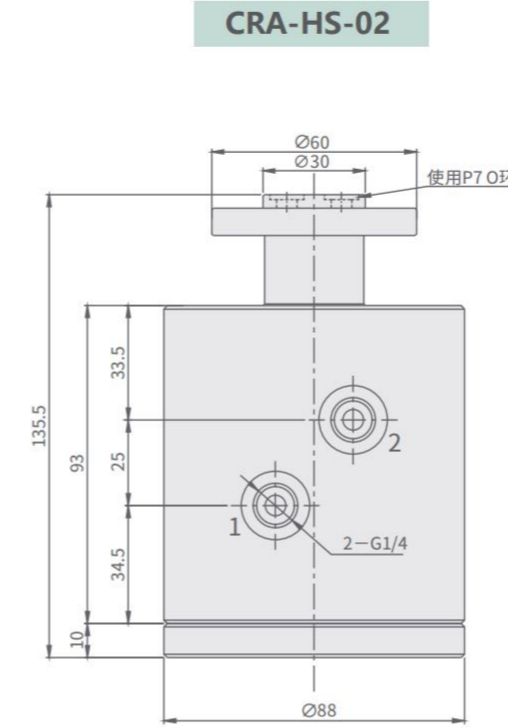

# HB

## 油压增压器

# HB HYDRAULIC BOOSTER



### 产品特性

本产品机构内附油压顺序阀，预压式特性操作时可将作动缸充满油，达到预先设定之压力，顺序阀动作，即可获得倍数增压。适用于油压专用机，MC 治具低压回路中，部份油压缸需高压操作之场合，仅需一只电磁阀或安装于管路中，即可操作HB增压器，可将低油压自动转换成高油压，获得高压支持。

最大操作压力: 50kgf/cm<sup>2</sup>  
最小操作压力: 20kgf/cm<sup>2</sup>

### FEATURES

A hydraulic sequential valve is attached to this booster. When operating, it oils cylinder and makes it be at the dual pressure and let the sequential valve act, and then it will have multiple boosting pressure. It's fit for hydraulic special purpose machine and MC damp in low pressure circuit. It needs a solenoid valve installed in the circuit, and then it will be able to operate HB super-charger. The super-charger may be converted automatically low oil- pressure into high oil-pressure and obtain a high pressure damping.

Max. operating pressure: 50kgf/cm<sup>2</sup>  
Min. operation pressure: 20kgf/cm<sup>2</sup>

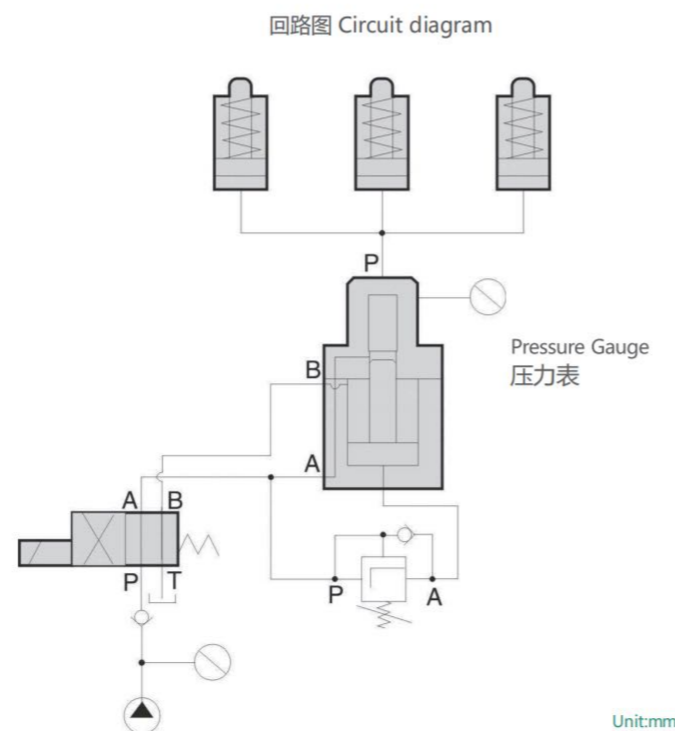
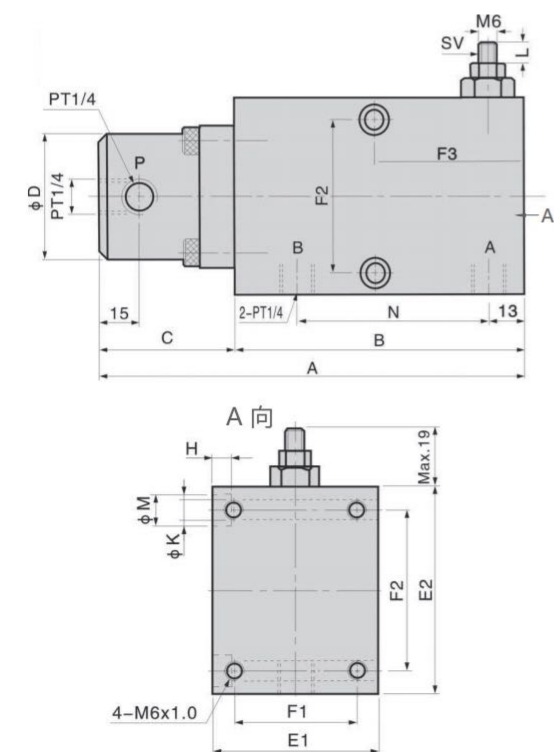

型号 Model	增压倍数 Multiple boost	高压吐油量 High pressure output	A	B	C	ΦD	E1	E2	F1	F2	F3	H	ΦK	ΦM	N
HB-9×6	9	6CC	157	107	50	Φ46	58	72	43	56	55	7	Φ7	Φ11	71
HB-8×22	8	22CC	210	139	71	Φ58	82	95	62	80	70	9	Φ9	Φ14	96
HB-5×35	5	35CC	210	139	71	Φ58	82	95	62	80	70	9	Φ9	Φ14	96
HB-3.8×45	3.8	45CC	210	139	71	Φ58	82	95	62	80	70	9	Φ9	Φ14	96

使用流体: 相当于ISO黏度等级的ISO-VG-32一般液压油 Recommended: ISO-VG-32 hydraulic oil equivalent to ISO viscosity grade

最高操作压力50kg/cm<sup>2</sup>  
Max.operation pressure

油路板型 Manifold type

HB-M3.5X15
HB-M5X10
HB-M9X6

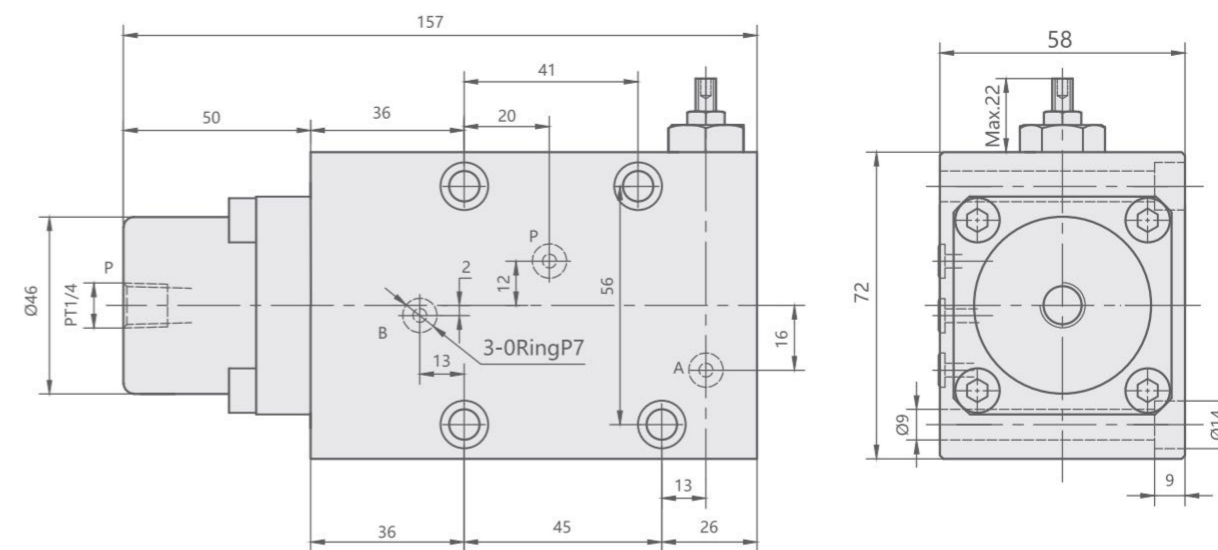

最高操作压力120kg/cm<sup>2</sup>  
Max.operation pressure

配管式 Line type

HB-3.2X25

油路板型 Manifold type

HB-M3.2X25

增压倍数 Multiple boost

3.2

高压吐油量 High pressure output

25cc

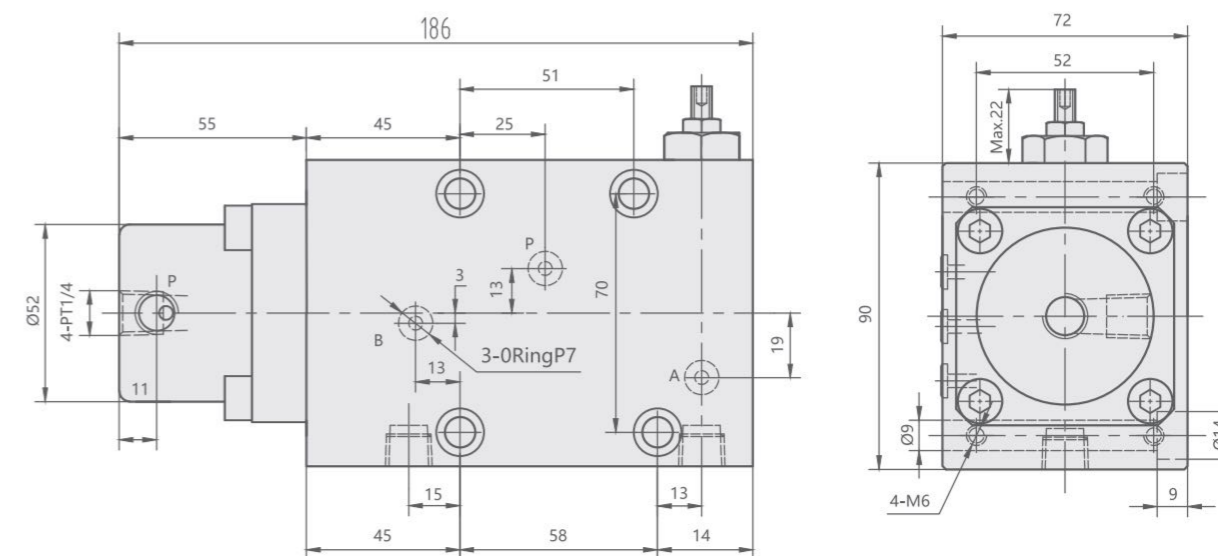

# CJSS

## 弹簧式蓄能器

# CJSS SPRING ACCUMULATOR



### 产品特性

透过弹簧式蓄能器吸收压力变动，防止因异常高压或低压而导致系统压力变化。

### FEATURES

Accumulator absorbs the pressure fluctuation so that it prevents system pressure from variation due to the high or low abnormal pressure.

### 选配项 OPTIONS

	分类	基准使用压力
	CLASSIFICATION	STANDARD OPERATING PRESSURE
	低压用弹簧式蓄能器 Spring Accumulator for Low Pressure	2/3/4/ MPa

### 订购标示法 ORDERING INDICATION

示例: CJSS-402HSB

CJSS	系列 Series	CJSS			
4	基准使用压力 Standard Operating Pressure	2 : 2.0MPa    3 : 3.0MPa    4 : 4.0MPa			
02	排出油量 Amount of Discharge Oil	02 : 2.5cm <sup>3</sup> 05 : 5.0cm <sup>3</sup> 10 : 10.0cm <sup>3</sup>			
H	安装方向 Mounting Direction	H: 横向安装 H : Horizontal Mounting	V: 纵向安装 V : Vertical Mounting		
S	配管方式 Piping Method	C : 外配管型 (G螺纹) Piping Option (BSPP Thread (G-Thread)) S : 外配管型 (Rc螺纹) Piping Option (BSPT (Rc-Thread)) G : 板式连接型 Gasket Option GC : 板式+外配管型(G螺纹)型 Gasket + Piping Option (BSPP Thread (G-Thread)) GS : 板式+外配管型(Rc螺纹)型 Gasket + Piping Option (BSPT (Rc-Thread))			
B	配管方向(H:仅限横向安装且为外配管型: C/S/GC/GS 的情况下) Piping Direction Selected for both H: Horizontal Mounting and Piping Method: C/S/GC/GS	A: 上面配管    A : Top Piping B: 侧面配管    B : Side Piping ※ V: 选择纵向安装时, 即为[无标记]. ※ For V: Vertical Mounting, Piping Direction is [Blank]. ※ H: 横向安装且为外配管型:选择G时, 即为[无标记]. ※ For H: Horizontal Mounting and Piping Method: G, Piping Direction is [Blank].			

### 特性表的解读方法

通过弹簧式蓄能器吸收压力变动，以防止因异常高压或低压而导致系统压力变化。

### HOW TO READ THE CHARACTERISTIC FORM

Accumulator absorbs the pressure fluctuation so that it prevents system pressure from variation due to the high or low abnormal pressure.

使用油缸	配管	阀类的容积	温度变化量	使用压力	热膨胀系数
Clamp Used	Piping	Valve Capacity	Temperature Change : ΔT	Operating Pressure : P	Thermal Expansion Coefficient : α
CHA-55×4 台 (1台油夹紧时的油容量 : 26.7cm <sup>3</sup> )	内径 φ6×2m (1m的配管容积: 28.3cm <sup>3</sup> )	20cm <sup>3</sup>	-20°C	4.0MPa	8×10 <sup>-4</sup>

### 选型方法

1. 夹具回路容积(V)的计算  
油缸容积+配管容积+阀类的容积  
 $V = (26.7 \times 4) + (28.3 \times 2) + 20 = 183.4 \text{ cm}^3$

2. 变化容积 (ΔV) 的计算  
夹具回路容量(V)×热膨胀系数(α)×温度变化量(ΔT)  
 $\Delta V = 183.4 \times (8 \times 10^{-4}) \times (-20) = -2.93 \text{ cm}^3$

3. 蓄能器型号的选定  
根据使用压力(P)= 4.0MPa, 选定 CJSS4□□□  
根据变化容积 (ΔV)= -2.93cm<sup>3</sup>, 选定 CJSS405 (变化容积超出范围时, 请考虑容积大的[CJSS410] 弹簧式蓄能器。)

4. 弹性蓄能器特性的确认  
温度变化(-20°C)后的压力: 2.92MPa  
残余吐出容积的剩余值: 2.07cm<sup>3</sup>

5. 请选定安装方向、配管口、配管方向。

### SELECTION METHOD

1. Calculate Fixture Circuit Capacity (V)  
Clamp Capacity + Pipe Capacity + Valve Capacity  
 $V = (26.7 \times 4) + (28.3 \times 2) + 20 = 183.4 \text{ cm}^3$

2. Calculate Change in Capacity (ΔV)  
Fixture Circuit Capacity (V) x Thermal Expansion Coefficient (α) x Amount of Temperature Change (ΔT),  $\Delta V = 183.4 \times (8 \times 10^{-4}) \times (-20) = -2.93 \text{ cm}^3$

3. Select Accumulator Mode  
Operating Pressure (P)= 4.0MPa select CJSS4□□□  
Change in Capacity (ΔV)= -2.93cm<sup>3</sup> select CJSS405. (If the required discharge capacity is greater than range select larger accumulator [e.g. CJSS410].)

4. Check the Accumulator Characteristics  
Pressure after Temperature Change (-20°C): 2.92MPa  
Residual Oil Discharge Margin : 2.07cm<sup>3</sup>

5. Select the Attachment and Piping Methods.

### 注意事项

1. 请考虑弹簧力的固有差异，在选择油容积时留有余量。  
【余量油量的标准: CJSS□02...0.5cm<sup>3</sup>、CJSS□05...1.0cm<sup>3</sup>、CJSS□10...1.5cm<sup>3</sup>】

### NOTE

1. When marking your selection, calculate tolerance for the oil capacity taking the spring force deviation into consideration.  
[Approximate amount of spare oil: CJSS□02...0.5cm<sup>3</sup>, CJSS□05...1.0cm<sup>3</sup>, CJSS□10...1.5cm<sup>3</sup>]

### 规格参数表 SPECIFICATIONS

型号	基准使用压力	耐压	吐出油量	吸入油量	压缩系数(β) ※1	重量	使用温度	使用流体
MODEL	STANDARD OPERATING PRESSURE (MPa)	WITHSTANDING PRESSURE (MPa)	DISCHARGE OIL CAPACITY (cm <sup>3</sup> )	ABSORBING CAPACITY (cm <sup>3</sup> )	Compression Factor(β) ※1 (MPa/cm <sup>3</sup> )	WEIGHT(kg)	OPERATING TEMPERATURE(°C)	USABLE FLUID
CJSS-202	2.0	14.0	2.5	1.0	0.40	0.8	0~70	相当于ISO黏度等级的ISO-VG-32一般液压油 Recommended: ISO-VG-32 hydraulic oil equivalent to ISO viscosity grade
CJSS-205	2.0	14.0	5.0	2.0	0.31	1.0	0~70	
CJSS-210	2.0	14.0	10.0	4.0	0.16	1.7	0~70	
CJSS-302	3.0	14.0	2.5	1.0	0.40	0.8	0~70	
CJSS-305	3.0	14.0	5.0	2.0	0.33	1.1	0~70	
CJSS-310	3.0	14.0	10.0	4.0	0.17	1.7	0~70	
CJSS-402	4.0	14.0	2.5	1.0	0.49	0.8	0~70	
CJSS-405	4.0	14.0	5.0	2.0	0.37	1.1	0~70	
CJSS-410	4.0	14.0	10.0	4.0	0.18	2.0	0~70	

## 外形尺寸 EXTERNAL DIMENSIONS

## 安装部位加工尺寸 MACHINING DIMENSIONS OF MOUNTING AREA

CJSS□02-H□□ CJSS□05-H□□

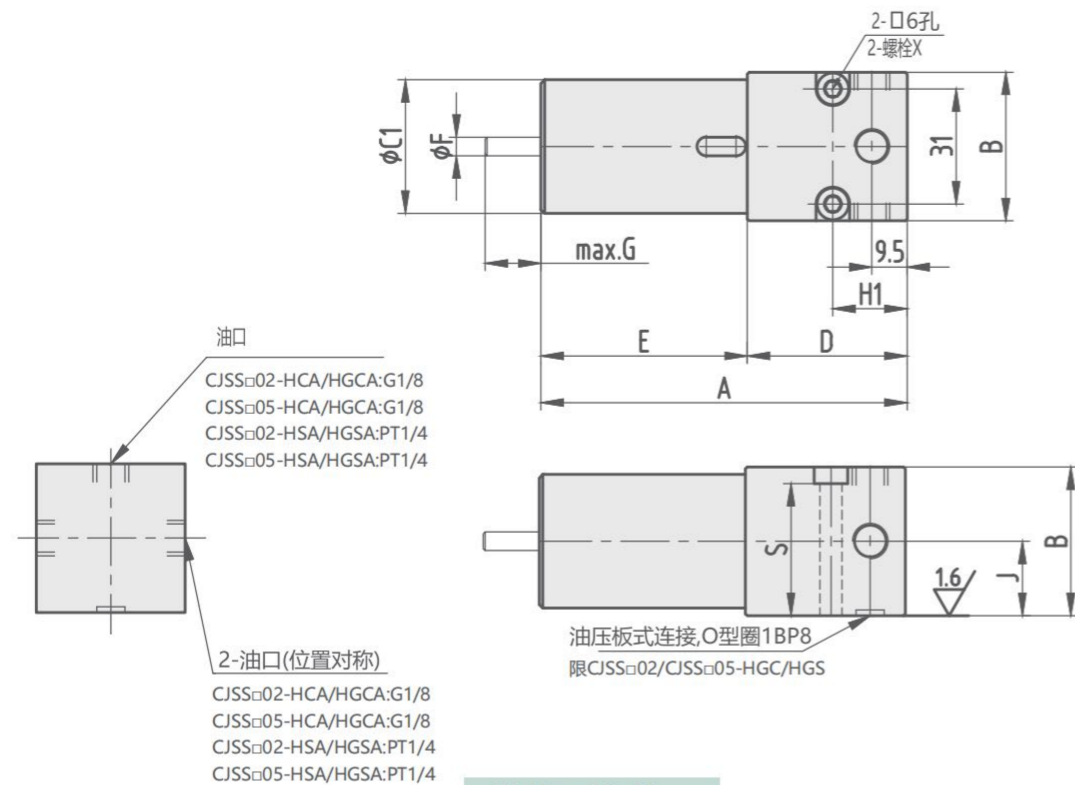

CJSS□ 10-H□□

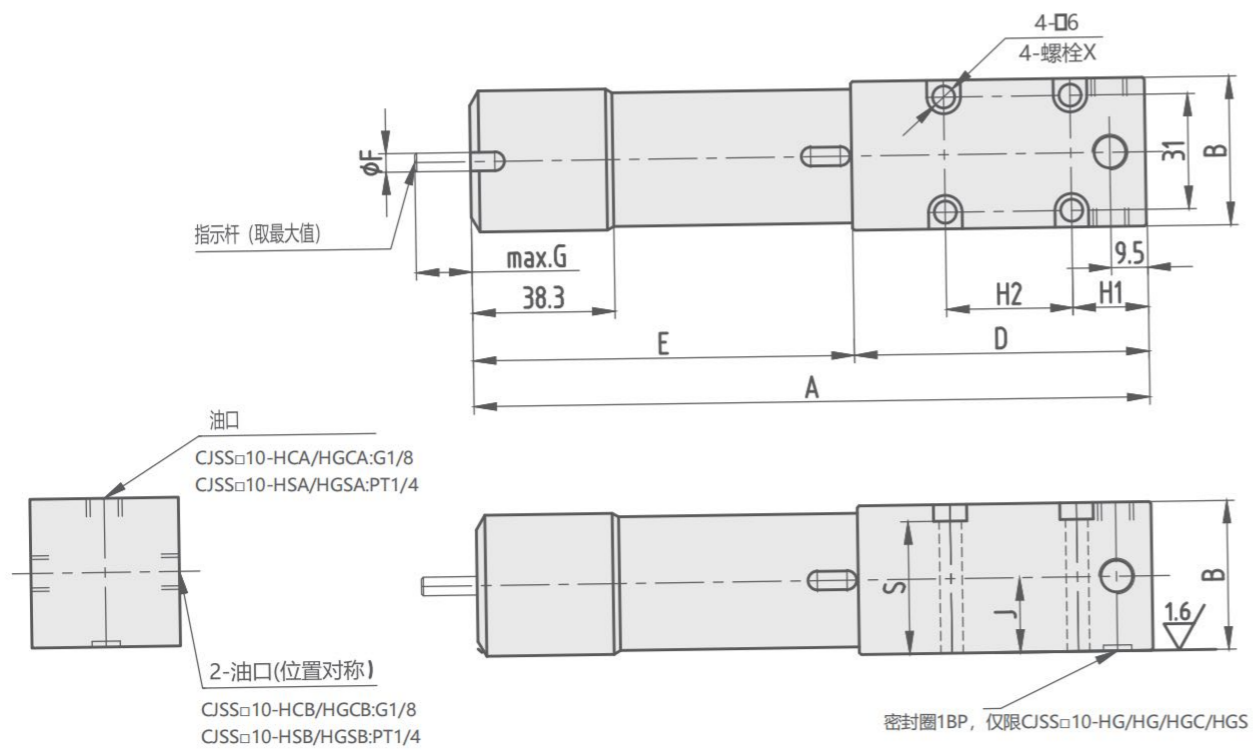

CJSS□02-V□

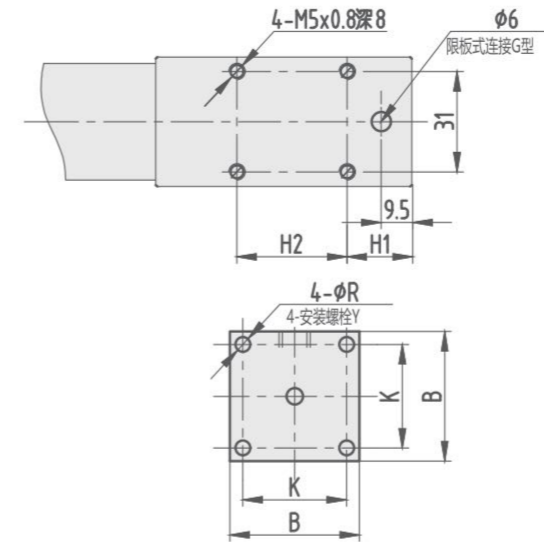

CJSS□10-V□

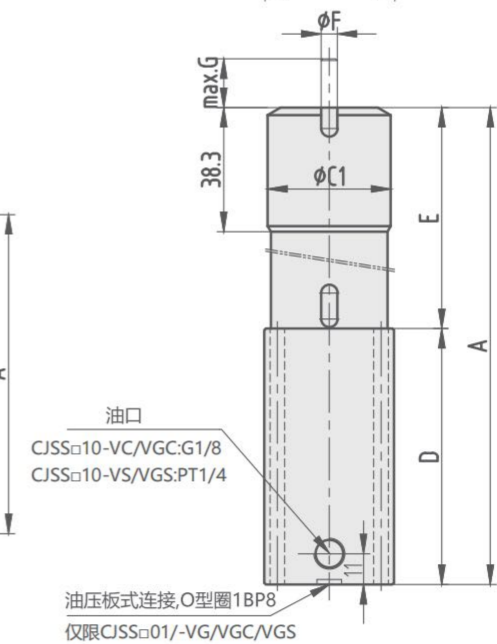
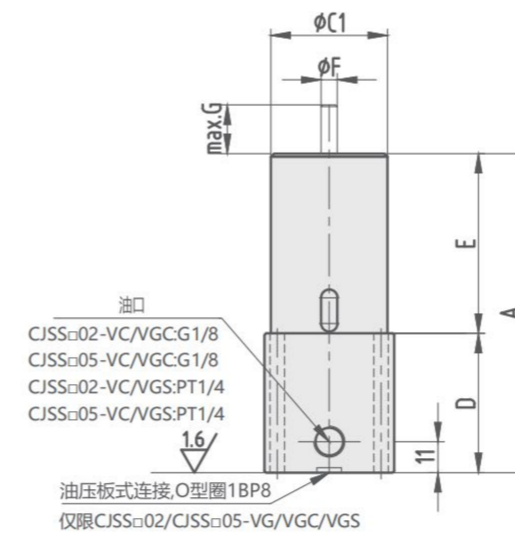
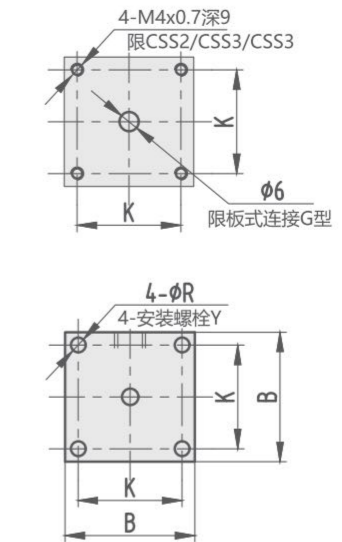

Unit:mm

MODEL	A	B	C1	C2	D	E	F	G <sup>※1</sup>	H1	H2	J	K	R	S	安装螺栓X Mounting Bolt X	安装螺栓X Mounting Bolt Y
CJSS202 CJSS302 CJSS402	98.5	40	36	—	43	55.5	5	15	20	—	20	32	4.5	34	M5×0.8×40	M4×0.7×50
CJSS205 CJSS305 CJSS405	136.5	40	36	—	55	81.5	5	27	20	—	20	32	4.5	34	M5×0.8×40	M4×0.7×60
CJSS210 CJSS310 CJSS410	241.5	40	38	36	79	162.5	5	49	20	34	20	32	4.5	34	M5×0.8×40	M4×0.7×85

### 注意事项

- ※1. 指示器会随压力变化而顶出。计划空间布置时需要考虑指示器的最大顶出量，以避免与其他部位的干涉。
- ※2. G(板式连接型)的安装面(O形密封圈密封面)的表面粗糙度应按6.3S加工。
- 1. 请勿擅自对本产品进行解体。产品内置有弹簧，擅自拆卸往往会导致零部件弹出，非常危险。

### NOTE

- ※1. Indicator extends proportionally to pressure. Be aware not to interfere with other devices of max. extension dimension when designing.
- ※2. Roughness of mounting surface (O ring seal surface) should be 6.3S or better.
- 1. Do not disassemble. Components include pressured spring parts. It is dangerous to disassemble.

# ADB-A

## 储能器

## ADB-A ACCUMULATOR



### 产品特性

隔膜式蓄能器具有储存能量、吸收冲击、补偿漏损、传递压力作紧急能源等作用。在液压系统中，能避免管路元件损坏，延长设备的使用寿命减少停工损失，提高系统的可靠性和工作效率，节约能源。具有结构紧凑、体积小、重量轻等优点。特别适合于工程矿山机械、汽车工业工程装载机、林业机械、液压机床、液压夹具和液压试验机等使用。

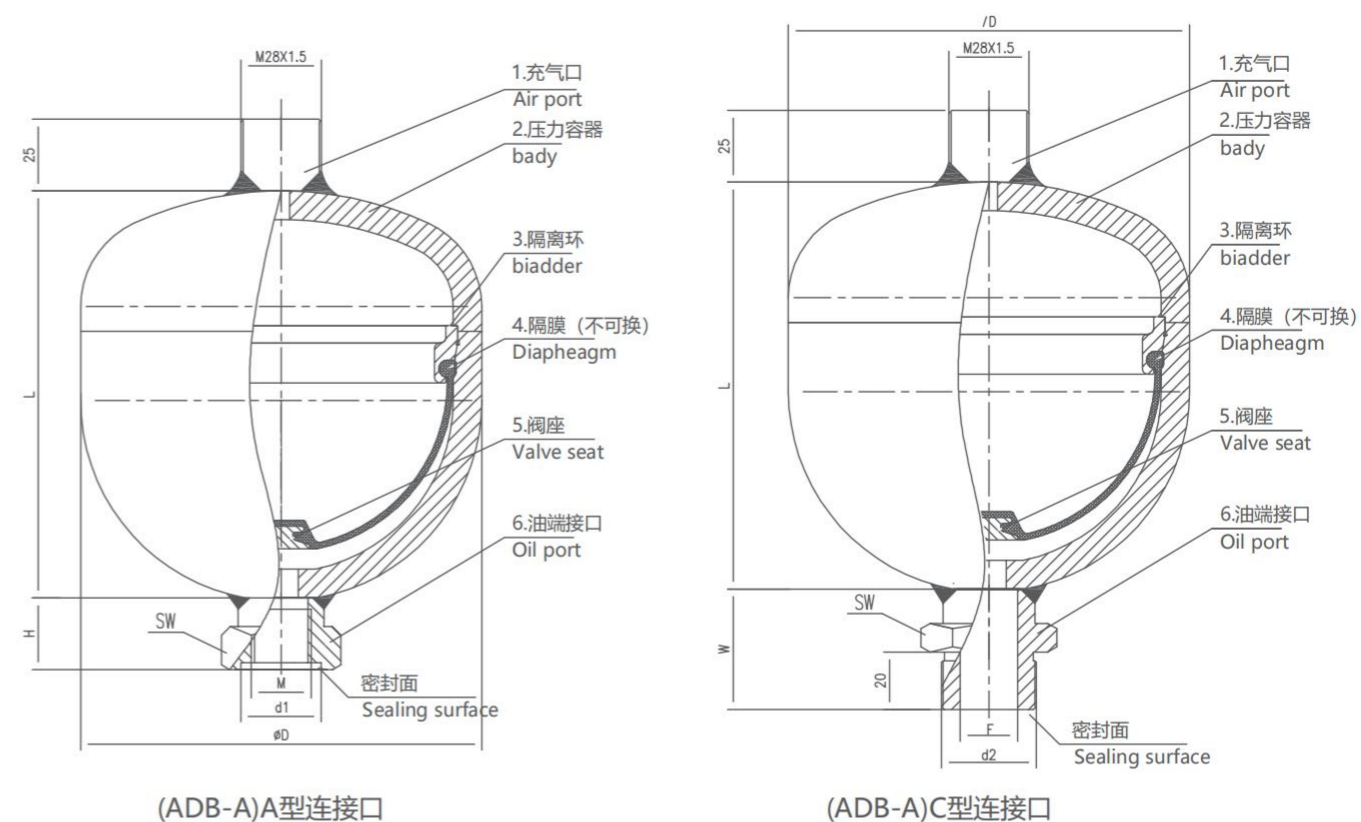

### 订购标示法 ORDERING INDICATION

示例: ADB-A/0075-33

ADB	系列 Series	ADB
A	连接方式	A型 C型
0075	公称容积	0.075L~3.5L
33	公称压力	33MPa
备注	充氮压力值	隔膜式蓄能器根据最低使用压力充氮。 充氮压力为最低工作压力的0.8倍, 订购时请备注充氮压力值。

### ADB数据表

Unit:mm

型号 Model	公称容积 Nominal Volume L	工作压力 Nominal Pressure MPa	ΦD mm	L mm	H mm	油端接口 Pore				W mm	SW mm	重量 Kg
						A型/O型圈		C型				
						公制/Metric M/d1	英制/Lnch M/d1	公制/Metric d2	英制/Lnch F			
ADB	0.075	10	64	70	M14×1.5/ (O型圈Φ25×2.4)	G1/2/ (O型圈Φ22×2.4)	M18×1.5	Φ6	36	32	1.5	
	0.16		74	80							2	
	0.25		84	85	M18×1.5/ (O型圈Φ22×2.4)		Φ20	2.5				
	0.32		93	93				3.5				
	0.5		103/107	113	M33×1.5 / M45×1.5		Φ20	4.0				
	0.6		111/115	122				5.0				
	0.75	121/125	126	M22×1.5/ (O型圈Φ30×3.1)	G3/4/ (O型圈Φ32×3.1)	M22×1.5 / G1/2	6.0					
	1	136/140	142				7.5					
	1.4	150/154	160	42	41/46	9.5						
	2	170/173	177			14.5						
	2.8	170/173	234			17.5						
	3.5	170/173	280	30			21.5					

# CMO

## 系列轻型油压缸

### CMO SERIES HYDRAULIC CYLINDER



#### 轻型油压缸结构图 INSIDE STRUCTURE

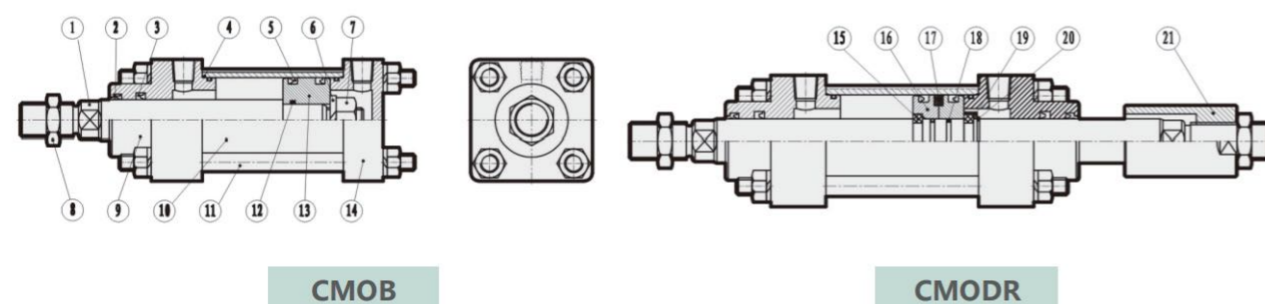

NO	零件名 Part name	数量 Quantity	NO	零件名 Part name	数量 Quantity	NO	零件名 Part name	数量 Quantity
1	活塞杆Piston rod	1	8	轴心螺母 Rod nut	1	15	半卡环Half snap ring	2
2	防尘油封Dustproof seal	1	9	前端盖Rod cover	1	16	铜活塞 Copper piston	1
3	轴用油封Oil seal for shaft	1	10	缸筒Cylinder tube	1	17	磁环Magnet ring	1
4	O型圈 Gasket	2	11	拉桿Tie rod	4	18	O型圈 Gasket	2
5	活塞油封Piston seal	2	12	O型圈 Gasket	1	19	挡环Baffle ring	1
6	弹性垫圈 Spring washer	1	13	活塞Piston	1	20	轴用挡圈Washer on shaft	1
7	螺母 Nut	1	14	后端盖End cover	1	21	可调螺母Adjustable nut	1

#### 轻型油压缸特性资料 Specifications

油缸内径Hydraulic cylinder inside diameter(mm)	Φ30	Φ40	Φ50	Φ63	Φ80	Φ100	Φ125
工作流体Power Fluid	以滤清之标准液压油Filtered Oil						
缸管材质Material of cylinder barrel	碳钢管 Carbon steel STKM-13c/白铁管 Stainless tubes SUS 304/AL Tube A6063TDS-T5						
使用压力范围The range of pressure(MPa)	0.3-7.0 MPa (3-70kg/cm <sup>2</sup> )						
使用速度范围The range of speed (mm/sec)	8~300(mm/sec)						
使用温度范围Range of temperature(°C)	-10 ~ + 60 (°C)						
标准活塞长度Length of standard piston (PM)	30	30	30	30	35	50	50
订制行程于1501-2500mm间活塞长度(PM) Piston length when the stroke is between 1501-2500 mm	60	60	60	60	70	100	100
订制行程于2501-4000mm间活塞长度(PM) Piston length when the stroke is between 2501-4000 mm	120	120	120	120	140	150	150

#### 订购标示法 ORDERING INDICATION

示例: CMOB-R-D-63/25-100-LB-Y

CMOB	系列 Series	CMOB标准型 Standard type		CMOD 双轴型 Double Rods type	
R	磁性感应 Magnetic	无记号: 不附磁石 R: 内附磁石	Blank: No magnet R:Magnet		
D	固定缓冲型式 Fixed Cushioning Type	无记号:无 F:前盖侧缓冲 B:后盖侧缓冲	Blank: No cushion D:双侧缓冲 cushions on both ends F:cushion on head cover B:cushion on end cover		
63	油缸内径 Hydraulic cylinder inside diameter		Φ30 Φ40 Φ50 Φ63 Φ80 Φ100 Φ125		
25	轴心 Rod	标准Standard 最大Max 无记号:标准轴心 Blank: standard rod	Φ16 Φ20 Φ20 Φ25 Φ30 Φ35 Φ50 - Φ25 Φ30 Φ35 Φ40 Φ50 Φ60		
100	行程 Stroke	无记号:标准轴心 钢管Steel barrel (Φ30-Φ125) 白钢管Iron barrel (Φ40-Φ100) 标准行程Standard stroke: 50, 100, 150, 200, 250, 300, 350, 400, 450, 500, 600, 700, 800, 900, 1000.		最大行程: 4米 Max:4m 最大行程: 2.8米 Max:2.8m	
LB	缸体固定型式 Accessories for body		FA 前法兰型 Front flange FB 后法兰 Rear flange LB 脚座型 Foot mount TC 耳轴型 Trunnion type	CA 单耳型 Single trunnion CB 双耳型 Double trunnion CBP CB+Pin CB with pin CAB CA+P+CB	
Y	轴心固定型式 Accessories for rod		Y Y型接头 Y joint YP Y+Pin Y with pin I I型接头 I joint KG 浮动接头 Floating joint	PHS 鱼眼接头 Rod-eye joint T T型接头 T joint H 焊套接头 Welding sleeve joint A 可调螺帽 Adjustable nut	

CMOB基本型 CMOB BASIC TYPE

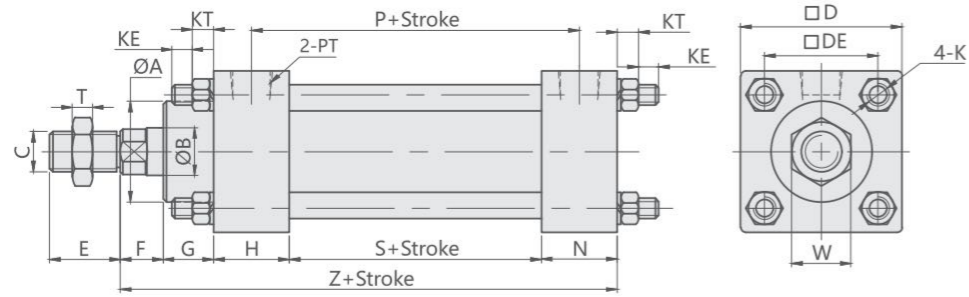

CMOD 双轴型 CMOD DOUBLE-END ROD

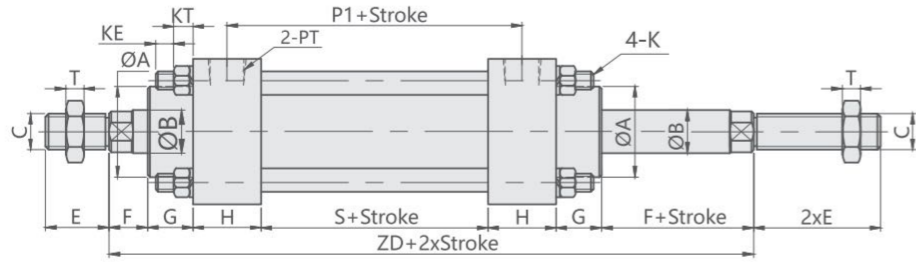

CMOD-A双轴可调型 CMOD-A ADJUSTABLE DOUBLE-END ROD

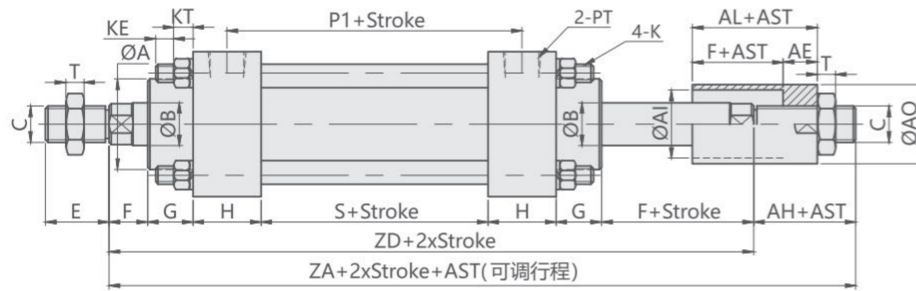

Unit:mm

CMOB-CMOD TYPE																											
BORE	ΦA	ΦB	C	□D	□DE	E	F	G	H	N	P	P1	PT	K	KE	KT	S	W	T	Z	ZA	ZD	AH	AE	ΦAI	ΦAO	AL
Φ30	30	16	M14x1.5	50	34	28	13	15	25	25	75	75	1/4"	M8X1.25	8	8.5	50	22	8	128	181	156	25	17	20	30	30
Φ40	40	20	M16x1.5	64	45	28	17	20	30	30	80	80	3/8"	M8X1.25	8	8.5	50	23.5	8	147	209	184	25	18	30	35	35
Φ50	45	20	M16x1.5	70	50	28	17	20	30	28	75	75	3/8"	M10X1.25	10	10.5	50	23.5	8	145	209	184	25	18	30	35	35
Φ63	55	25	M22x1.5	85	60	40	20	30	31	31	81	81	3/8"	M10X1.25	10	10.5	50	32	13	162	247	212	35	20	35	45	40
Φ80	62	30	M26x1.5	106	74	40	20	32	37	35	91	92	1/2"	M12X1.25	10	13	55	35	13	179	268	233	35	20	40	50	40
Φ100	78	35	M30x1.5	122	89	45	20	32	37	37	117	117	1/2"	M14X1.5	10	14.5	80	41	13	206	298	258	40	25	45	60	45
Φ125	85	50	M40x2.0	147	110	55	25	31	40	40	120	120	1/2"	M16X1.5	10	17	80	55	15	216	322	272	50	30	60	80	55

注意事项

- 1.轴心加大如未注明长度尺寸时, 依照本公司规定自行加工。
- 2.CFO系列行程未超过1500mm时, 活塞长度(PM)如附表, 订制行程如超过1500mm时, 活塞长度参阅特性资料表。
- 3.CMO系列行程超过2000mm(含)时, 须加拉杆中间固定座。
- 4.CMO系列缸径40-50油缸之行程超过500mm(含)以上时, 轴心牙改为M18\*P1.5。
- 5.AST为客户指定之可调行程。

NOTE

1. For rods extending processing, if the length is not specified, then it should follow our company's stipulation for processing.
2. For the CMO series whose stroke is less than 1500mm, the length of piston is shown in the affiliated table, for those customized stroke, which is more than 1500mm, the length of piston conforms to characteristic table.
3. Middle rod holder must be installed for those CMO series whose stroke is equal to or more than 2000mm.
4. Rod thread should be changed into M18\*P1.5 for CMO series bore size 40-50, whose stroke is equal to or more than 500mm.
5. AST stands for the adjustable stroke designated by customers.

CMOB-FA 前法兰型 CMOB-FA FRONT FLANGE TYPE

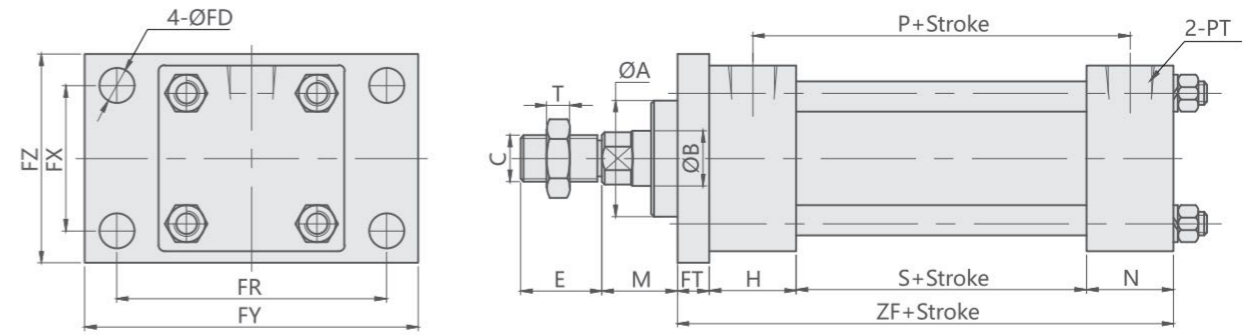

CMOB-FB 后法兰型 CMOB-FB REAR FLANGE TYPE

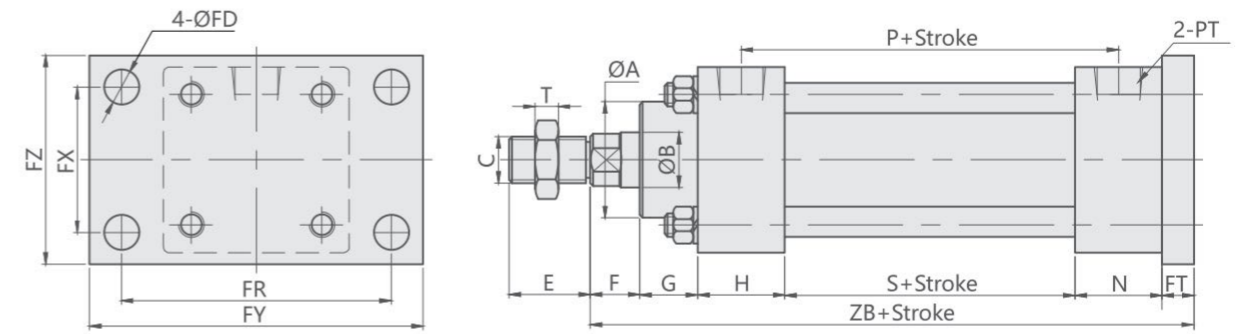

CMOB+TC 中耳轴型 CMOB+TC MIDDLE TRUNNION TYPE

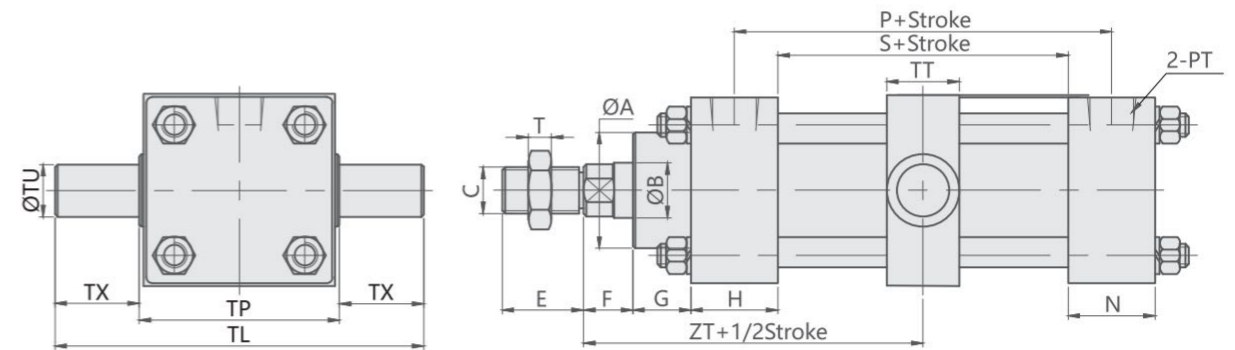

Unit:mm

CMOB TYPE														FA+FB TYPE						TC TYPE								
BORE	ΦA	ΦB	C	E	F	G	H	M	N	P	P1	PT	S	T	ZF	ZB	FD	FT	FR	FX	FY	FZ	ZT	TL	TP	TT	ΦTU	TX
Φ30	30	16	M14x1.5	28	13	15	25	17	25	75	75	1/4"	50	8	111	139	9	11	80	34	105	52	78	87	55	25	16	16
Φ40	40	20	M16x1.5	28	17	20	30	26	30	80	80	3/8"	50	8	121	158	12	11	93	50	115	72	92	127	69	25	18	29
Φ50	45	20	M16x1.5	28	17	20	30	26	28	79	80	3/8"	50	8	119	156	12	11	93	50	115	72	92	153	83	28	20	35
Φ63	55	25	M22x1.5	40	20	30	31	36	31	81	81	3/8"	50	13	126	176	14	14	117	60	140	90	106	170	98	32	25	36
Φ80	62	30	M26x1.5	40	20	32	37	32	35	91	92	1/2"	55	13	147	199	14	20	152	75	180	106	116.5	194	124	35	28	35
Φ100	78	35	M30x1.5	45	20	32	37	32	37	117	117	1/2"	80	13	174	226	16	20	158	90	200	125	129	222	142	38	30	40
Φ125	85	50	M40x2.0	55	25	31	40	36	40	120	120	1/2"	80	15	180	236	18	20	184	110	225	153	136	255	175	40	32	40

### CMOB+CA 单耳型 Single Trunnion Mounting Type

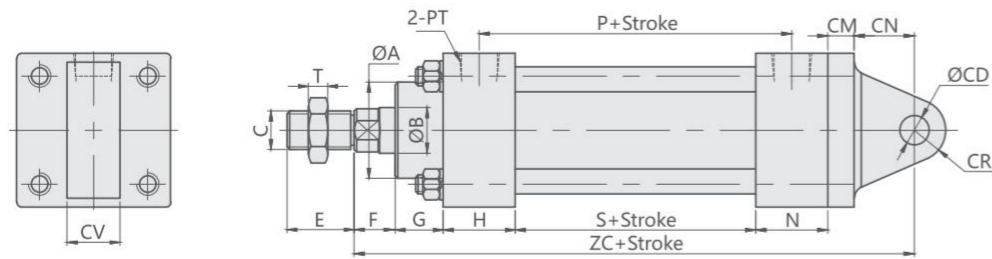

### CMOB+CB 双耳型 Double Trunnion Mounting Type

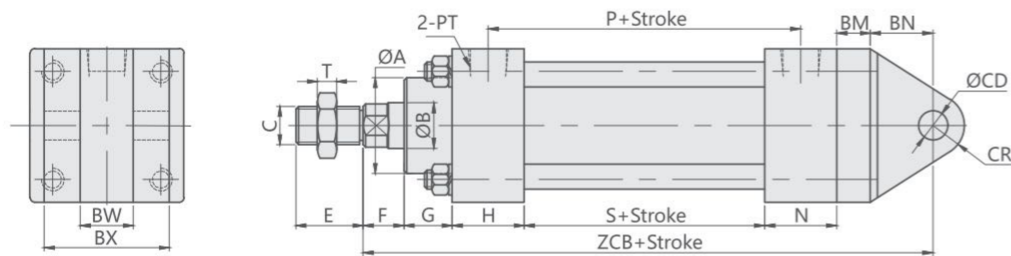

### CMOB+LB 前后脚座型 Front & Rear Foot Mounting Type

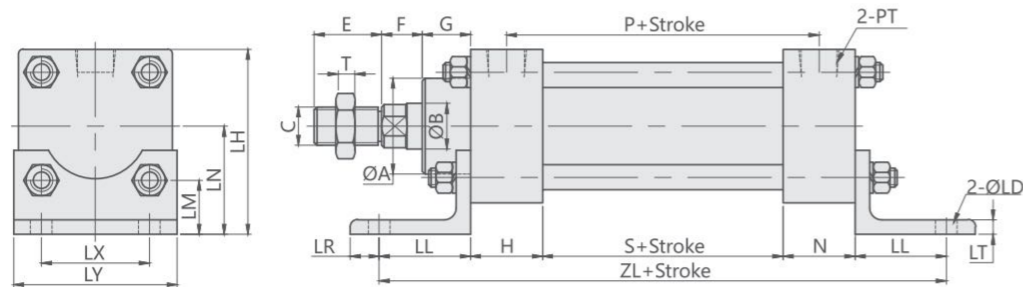

Unit:mm

CMOB TYPE														CA+CB TYPE																			
BORE	ΦA	ΦB	C	E	F	G	H	N	P	PT	S	T	ZC	ΦCD	CR	CM	CN	CV	ZCB	BM	BN	BW	BX	ZL	ΦLD	LH	LN	LM	LL	LR	LT	LX	LY
Φ30	30	16	M14x1.5	28	13	15	25	25	75	1/4"	50	8	159	10	10	11	20	16	162	12	22	16	48	156	9	60	35	18	28	10	5	34	53
Φ40	40	20	M16x1.5	28	17	20	30	30	80	3/8"	50	8	183	12	13	11	25	22	187	14	26	22	62	186	9	77	45	22.5	38	12	6	45	68
Φ50	45	20	M16x1.5	28	17	20	30	28	79	3/8"	50	8	181	12	13	12	24	22	185	14	26	22	68	184	11	81	46	21	38	12	6	50	73
Φ63	55	25	M22x1.5	40	20	30	31	31	81	3/8"	50	13	212	20	24	19	31	30	212	18	32	30	81	188	11	96	53	23	38	12	6	60	88
Φ80	62	30	M26x1.5	40	20	32	37	35	91	1/2"	55	13	247	30	30	18	50	30	247	18	50	31	61	199	13	113	60	23	36	14	6	74	105
Φ100	78	35	M30x1.5	45	20	32	37	37	117	1/2"	80	13	279	35	35	18	55	35	279	18	55	36	76	250	16	139	78	33.5	48	27	9	89	127
Φ125	85	50	M40x2.0	55	25	31	40	40	120	1/2"	80	15	289	35	35	18	55	35	289	18	55	36	76	262	18	161	87	32	51	24	9	110	150



# CHO

## 系列重型油压缸

### CHO SERIES HYDRAULIC CYLINDER



#### 重型油压缸结构图 INSIDE STRUCTURE

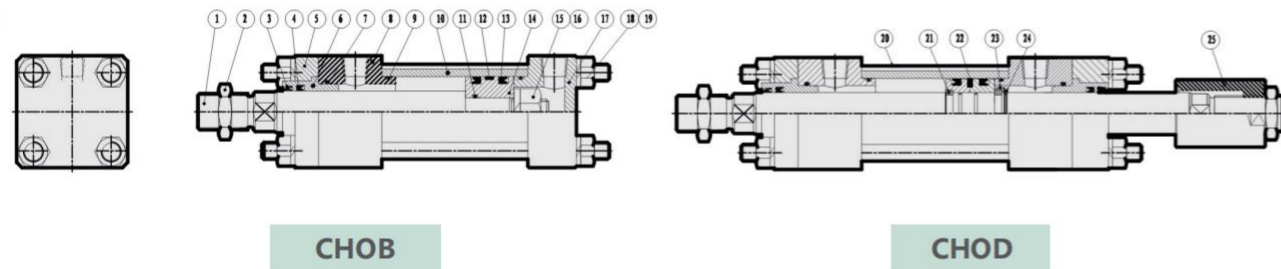

NO	零件名Part name	数量Quantity	NO	零件名Part name	数量Quantity	NO	零件名Part name	数量Quantity
1	活塞杆Piston rod	1	9,11	O型圈Gasket	3	18	螺母nut	8
2	锁紧螺母Locking nut	1	10	缸筒Cylinder tube	1	19	弹性垫圈Spring washer	8
3	防尘油封Dustproof seal	1	12	耐磨环Wearing ring	1	20	拉杆Tie rod	4
4	轴用油封Oil seal for shaft	1	13	活塞油封Piston seal	2	21	半卡环Half snap ring	2
5	压盖Gland	1	14	活塞Piston	1	22	磁环Magnet ring	1
6	导向套Guide sleeve	1	15	螺母Nut	1	23	挡环Baffle ring	1
7	O型圈Gasket	1	16	弹性垫圈Spring washer	1	24	轴用挡圈Rod baffle ring	1
8	前端盖Rod cover	1	17	后端盖End cover	1	25	可调螺母Adjustable nut	1

#### 重型油压缸特性资料 Specifications

油缸内径 Hydraulic cylinder inside diameter(mm)	Φ40	Φ50	Φ63	Φ80	Φ100	Φ125	Φ150	Φ180	Φ200
工作流体 Power Fluid	以滤清之标准液压油 Filtered Oil								
缸管材质 Material of cylinder barrel	碳钢管 Carbon steel STKM-13c/白铁管 Stainless tubes SUS 304								
使用压力范围 The range of pressure(MPa)	0.3-14 MPa (3-140kg/cm <sup>2</sup> )								
使用速度范围 The range of speed (mm/sec)	8~300(mm/sec)								
使用温度范围 Range of temperature(°C)	-10 ~ + 60 (°C)								
缓冲行程 Cushion stroke(mm)	25	25	25	30	35	40	45	50	55
标准活塞长度 Length of standard piston (PM)	30	35	35	50	60	70	60	70	70
订制行程于 1501-2500mm 间活塞长度 (PM) Piston length when the stroke is between 1501-2500 mm	60	70	70	80	100	100	100	140	140
订制行程于 2501-4000mm 间活塞长度 (PM) Piston length when the stroke is between 2501-4000 mm	120	140	140	150	180	180	180	200	200

#### 订购标示法 ORDERING INDICATION

示例:CHOB-R-D-63/35-100-LB-Y

<b>CHOB</b>	系列 Series	CHOB 标准型 Standard type		CHOD 双轴型 Double Rods type	
<b>R</b>	磁性感应 Magnetic	无记号:不附磁石 Blank: No magnet R: 内附磁石 (适用Φ40-Φ100) With magnet		本系列适用Φ40-Φ100 apply to bore Φ40-Φ100	
<b>D</b>	固定缓冲型式 Fixed Cushioning Type	无记号:无 Blank: No cushion D: 双侧缓冲 cushions on both ends F: 前盖侧缓冲 cushion on head cover B: 后盖侧缓冲 cushion on end cover			
<b>63</b>	油缸内径 Hydraulic cylinder inside diameter		Φ40 Φ50 Φ63 Φ80 Φ100 Φ125 Φ150 Φ180 Φ200		
<b>35</b>	轴心 Rod	标准Standard Φ25 Φ30 Φ35 Φ40 Φ50 Φ60 Φ80 Φ100 Φ100 最大Max - Φ35 Φ40 Φ50 Φ60 Φ80 Φ100 Φ120 Φ120 无记号:标准轴心 Blank: standard rod			
<b>100</b>	行程 Stroke	钢管Steel barrel (Φ40-Φ125) 白钢管Iron barrel (Φ40-Φ100) 标准行程 Standard stroke: 50, 100, 150, 200, 250, 300, 350, 400, 450, 500, 600, 700, 800, 900, 1000.		最大行程: 4米 Max:4m 最大行程: 2.8米 Max:2.8m	
<b>LB</b>	缸体固定型式 Accessories for body	FA 前法兰型 Front flange	FB 后法兰 Rear flange	LB 脚座型 Foot mount	LA 脚座型 Foot type
		CA 单耳型 Single trunnion	CB 双耳型 Double trunnion	CBP CB附Pin CB with pin	CAB CA+P+CB
<b>Y</b>	轴心固定型式 Accessories for rod	Y Y型接头 Y joint	YP Y+Pin Y with pin	I I型接头 I joint	KG 浮动接头 Floating joint
		PHS 鱼眼接头 Rod-eye joint	T T型接头 T joint	H 焊接接头 Welding sleeve joint	A 可调螺帽 Adjustable nut

CHOB基本型 CHOB BASIC TYPE

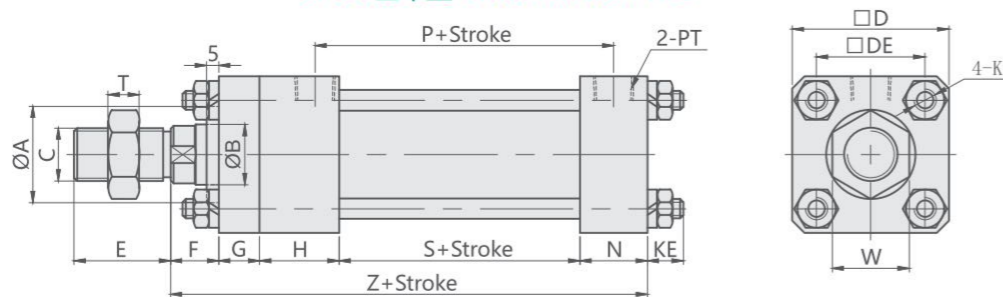

CHOD 双轴型 CHOD DOUBLE END ROD TYPE

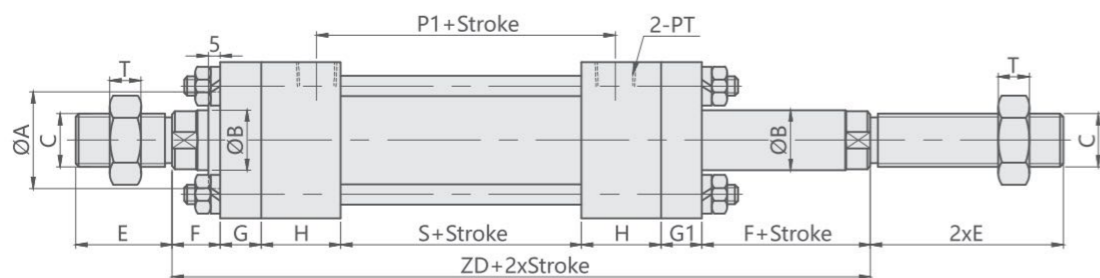

CHOD-A 双轴型附可调帽 CHOD-A ADJUSTABLE DOUBLE END ROD TYPE

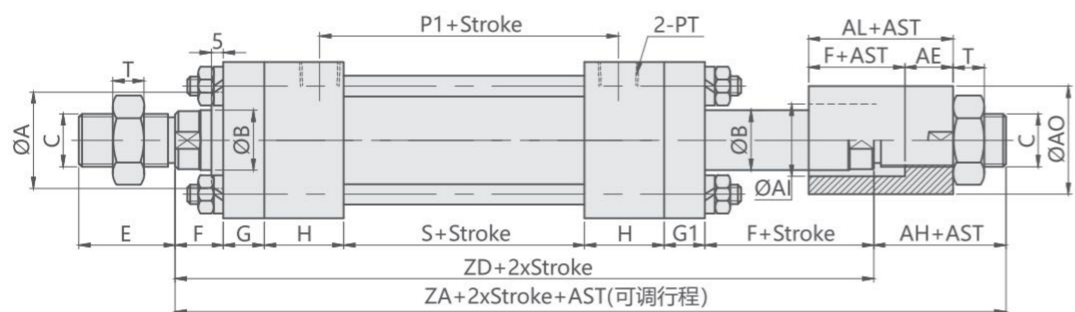

Unit:mm

CHOB-CHOD TYPE																	A(可调行程)TYPE										
BORE	ΦA	ΦB	C	□D	□DE	E	F	G	H	N	P	P1	PT	K	KE	G1	S	T	W	Z	ZD	ZA	AH	AE	AI	AO	AL
Φ40	40	25	M22xP1.5	65	45	40	20	17	33	28	76	74	3/8"	M10x1.25	20.5	22	50	13	32	148	195	230	35	20	30	45	40
Φ50	50	30	M26xP1.5	80	56	40	20	17	38	30	85	85	3/8"	M12x1.5	23	22	55	13	35	160	210	250	40	25	37	55	45
Φ63	55	35	M30xP1.5	90	63	45	20	17	38	30	85	85	3/8"	M14x1.5	24.5	22	55	13	41	160	210	250	40	25	42	60	45
Φ80	60	40	M30xP1.5	110	80	45	20	20	38	35	107	105	1/2"	M16x1.5	27	25	75	13	41	188	236	281	45	30	47	70	50
Φ100	80	50	M40xP2.0	131	95	55	25	20	41	37	123.5	120	1/2"	M18x1.5	29.5	25	90	15	55	213	267	312	45	30	57	90	55
Φ125	90	60	M50xP2.0	162	122	70	35	30	57	47	143	140	3/4"	M22x1.5	33.5	35	100	15	65	269	349	399	50	35	68	100	70
Φ150	110	80	M70xP2.0	195	144	80	35	30	60	50	135	130	3/4"	1-8UNC	46	35	90	20	90	265	345	405	60	40	90	120	75
Φ180	135	100	M90xP2.0	235	175	100	35	40	65	55	172	170	1"	M30x2.0	59	45	120	20	110	315	405	470	65	45	110	150	75
Φ200	135	100	M90xP2.0	262	193	100	40	40	65	60	175	170	1"	M33x2.0	59	45	120	20	110	325	415	480	65	40	110	150	80

注意事项

- 1.轴心加大如未注明长度尺寸时, 依照本公司规定自行加工。
- 2.CHO系列行程未超过1500mm时, 活塞长度(PM)如附表, 订制行程如超过1500mm时, 活塞长度(PM)请参阅特性资料表。
- 3.本系列行程超过2000mm(含)时, 须加拉杆中间固定座。
- 4.本系列行程轴心螺帽规格M50mm(含)以上时, 其外径为圆形。
- 5.AST为客户指定之可调行程。

NOTE

1. For rods extending processing,if the length is not specified,then it should follow our company's stipulation for processing.
2. For the CHO series whose stroke is less than 1500mm the length of the piston is shown in the affiliated table,for those customized stroke . Which is more than 1500mm,the length of piston conforms to characteristic table.
- 3.Middle rod holder must be installed for those CHO series whose stroke is equal to or more than 2000mm.
4. The external diameter would be round when the size of rod nut is equal to or more than M50mm.
- 5.AST stands for adjustable stroke designated by customers.

CHOB-FA前法兰型 CHOB-FA FRONT FLANGE TYPE

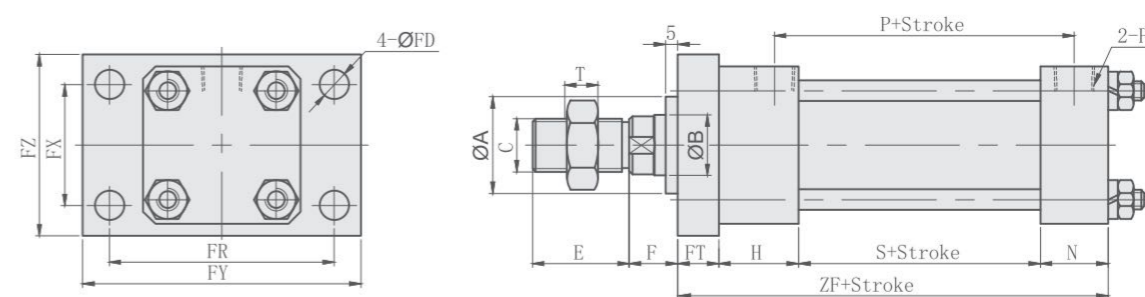

CHOB-FB后法兰型 CHOB-FB REAR FLANGE TYPE

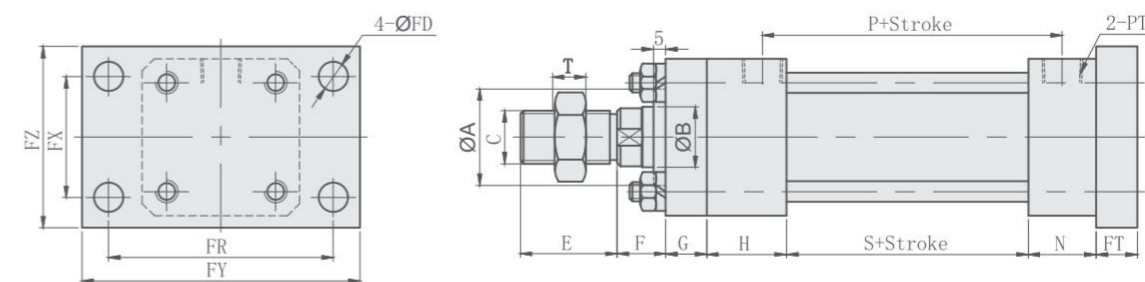

CHOD-FA 双轴前法兰型 CHOD-FA DOUBLE END FRONT FLANGE TYPE

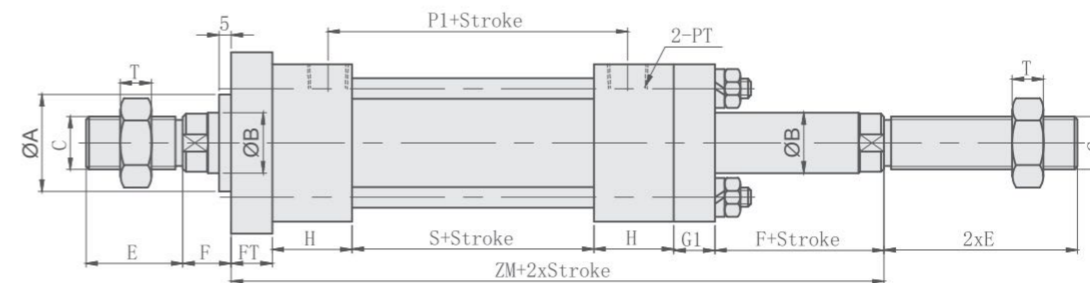

Unit:mm

CHOB-CHOD TYPE																	FA-FB TYPE						
BORE	ΦA	ΦB	C	E	F	G	H	N	P	P1	PT	S	G1	ZF	ZM	ΦFD	FR	FT	FX	FY	FZ		
Φ40	40	25	M22xP1.5	40	20	17	33	28	76	74	3/8"	50	22	128	175	12	93	17	50	115	75		
Φ50	50	30	M26xP1.5	40	20	17	38	30	85	85	3/8"	55	22	140	190	14	110	17	56	150	85		
Φ63	55	35	M30xP1.5	45	20	17	38	30	85	85	3/8"	55	22	140	190	14	126	17	68	155	95		
Φ80	60	40	M30xP1.5	45	20	20	38	35	107	105	1/2"	75	25	168	216	18	152	20	75	190	120		
Φ100	80	50	M40xP2.0	55	25	20	41	37	123.5	120	1/2"	90	25	188	242	20	180	20	100	220	140		
Φ125	90	60	M50xP2.0	70	35	30	57	47	143	140	3/4"	100	35	234	314	24	222	30	122	280	170		
Φ150	110	80	M70xP2.0	80	35	30	60	50	135	130	3/4"	90	35	230	310	28	260	30	155	310	206		
Φ180	135	100	M90xP2.0	100	35	40	65	55	172	170	1"	120	45	280	370	35	315	40	188	375	250		
Φ200	135	100	M90xP2.0	100	40	40	65	60	175	170	1"	120	45	285	375	35	355	40	207	425	272		

注意事项

- 1.轴心加大如未注明长度尺寸时, 依照本公司规定自行加工。
- 2.CHO系列行程未超过1500mm时, 活塞长度(PM)如附表, 订制行程如超过1500mm时, 活塞长度(PM)请参阅特性资料表。
- 3.本系列轴心螺帽规格M50mm(含)以上时, 其外径为圆形。

NOTE

1. For rods extending processing,if the length is not specified,then it should follow our company's stipulation for processing.
2. For the CHO series whose stroke is less than 1500mm,the length of piston is shown in the affiliated table,for those customized stroke . Which is more than 1500mm,the length of piston conforms to characteristic table.
- 3.The external diameter would be round when the size of rod nut is more than M50mm.

CHOB+TC中耳轴型 CHOB+TC MIDDLE TRUNNION TYPE

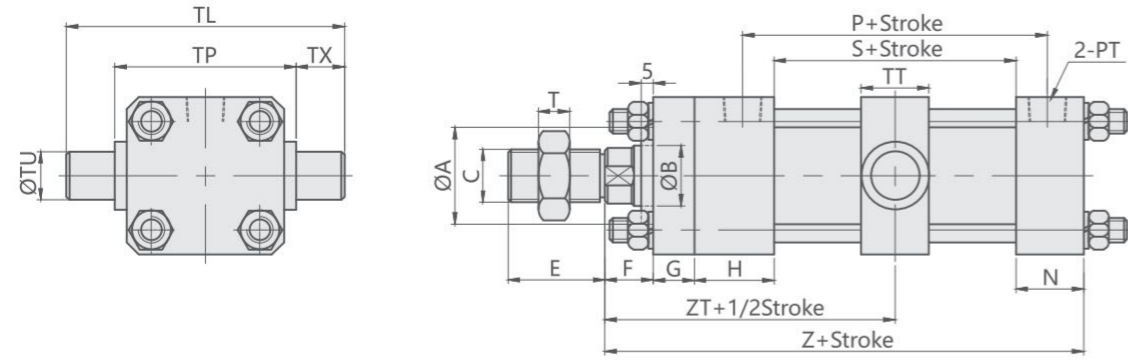

CHOB+TA前耳轴型 CHOB+TA FRONT TRUNNION TYPE

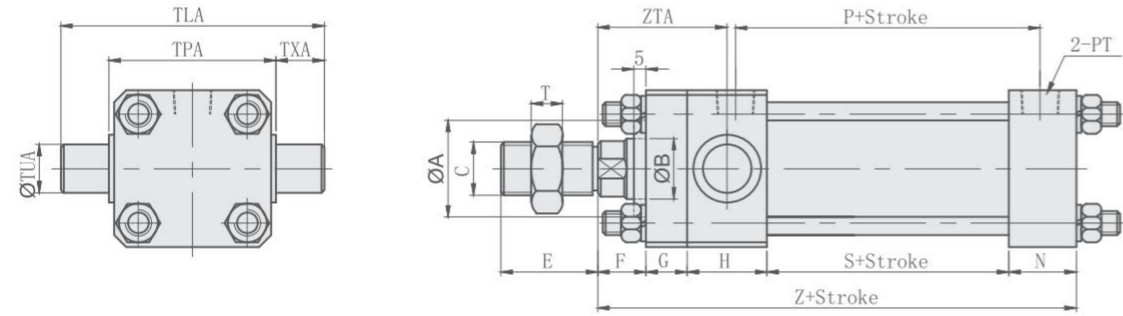

Unit:mm

CHOB TYPE													TC TYPE					TA TYPE						
BORE	ΦA	ΦB	C	E	F	G	H	N	P	PT	S	T	Z	ZT	ΦTU	TL	TP	TT	TX	ΦTUA	TLA	TPA	TXA	ZTA
Φ40	40	25	M22xP1.5	40	20	17	33	28	76	3/8"	50	13	148	95	20	115	75	28	20	20	109	69	20	53.5
Φ50	50	30	M26xP1.5	40	20	17	38	30	85	3/8"	55	13	160	102.5	25	140	90	33	25	25	134	84	25	56
Φ63	55	35	M30xP1.5	45	20	17	38	30	85	3/8"	55	13	160	102.5	32	166	102	40	32	30	154	94	30	56
Φ80	60	40	M30xP1.5	45	20	20	38	35	107	1/2"	75	13	188	115.5	32	184	120	43	32	30	174	114	30	59
Φ100	80	50	M40xP2.0	55	25	20	41	37	123.5	1/2"	90	15	213	131	40	220	140	53	40	35	205	135	35	65.5
Φ125	90	60	M50xP2.0	70	35	30	57	47	143	3/4"	100	15	269	172	50	275	175	58	50	45	258	168	45	93.5
Φ150	110	80	M70xP2.0	80	35	30	60	50	135	3/4"	90	20	265	170	60	326	206	73	60	50	300	200	50	95
Φ180	135	100	M90xP2.0	100	35	40	65	55	172	1"	120	20	315	200	80	403	243	98	80					
Φ200	135	100	M90xP2.0	100	40	40	65	60	175	1"	120	20	325	205	90	452	272	108	90					

CHOB+CA单耳环型 CHOB+CA SINGLE TRUNNION

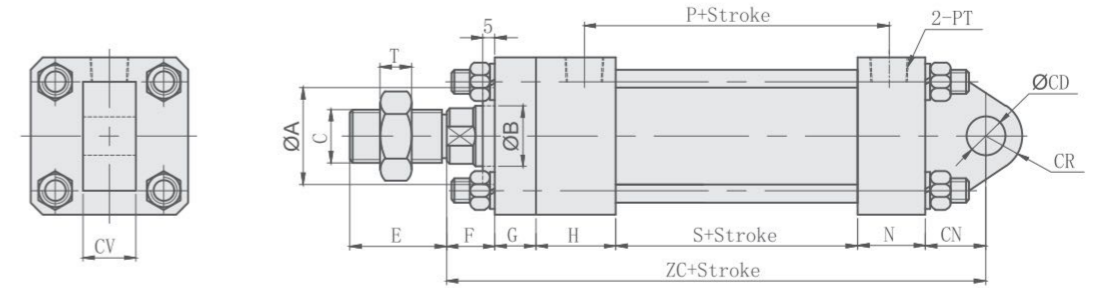

CHOB+CB双耳环型 CHOB+CB DOUBLE TRUNNION

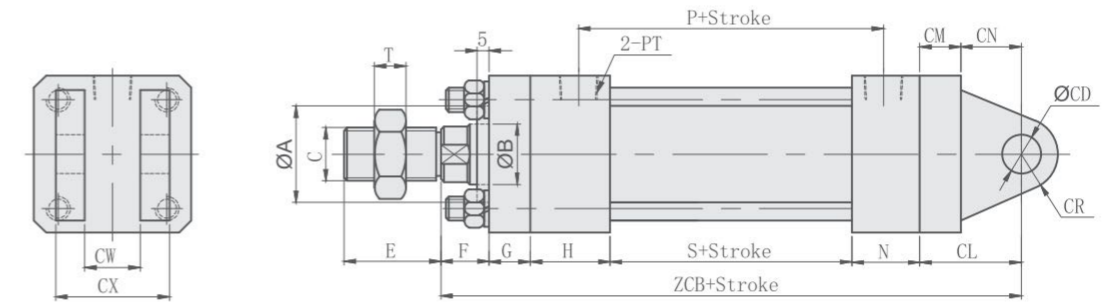

Unit:mm

CHOB TYPE													CA+CB TYPE										
BORE	ΦA	ΦB	C	E	F	G	H	N	P	PT	S	T	ZC	ZCB	ΦCD	CL	CM	CN	CR	CV	CW	CX	
Φ40	40	25	M22xP1.5	40	20	17	33	28	76	3/8"	50	13	173	190	16	42	17	25	15	22	23	47	
Φ50	50	30	M26xP1.5	40	20	17	38	30	85	3/8"	55	13	195	212	20	52	17	35	20	22	23	47	
Φ63	55	35	M30xP1.5	45	20	17	38	30	85	3/8"	55	13	205	222	25	62	17	45	25	30	31	59	
Φ80	60	40	M30xP1.5	45	20	20	38	35	107	1/2"	75	13	238	258	30	70	20	50	30	35	36	76	
Φ100	80	50	M40xP2.0	55	25	20	41	37	123.5	1/2"	90	15	273	293	35	80	20	60	35	40	41	81	
Φ125	90	60	M50xP2.0	70	35	30	57	47	143	3/4"	100	15	339	369	50	100	30	70	50	55	56	106	
Φ150	110	80	M70xP2.0	80	35	30	60	50	135	3/4"	90	20	345	375	60	110	30	80	60	60	61	121	
Φ180	135	100	M90xP2.0	100	35	40	65	55	172	1"	120	20	415	455	80	140	40	100	80	80	81	161	
Φ200	135	100	M90xP2.0	100	40	40	65	60	175	1"	120	20	435	475	90	150	40	110	90	90	91	171	

CHOB+LA 左右脚座型 CHOB+LA FEET SEAT TYPE

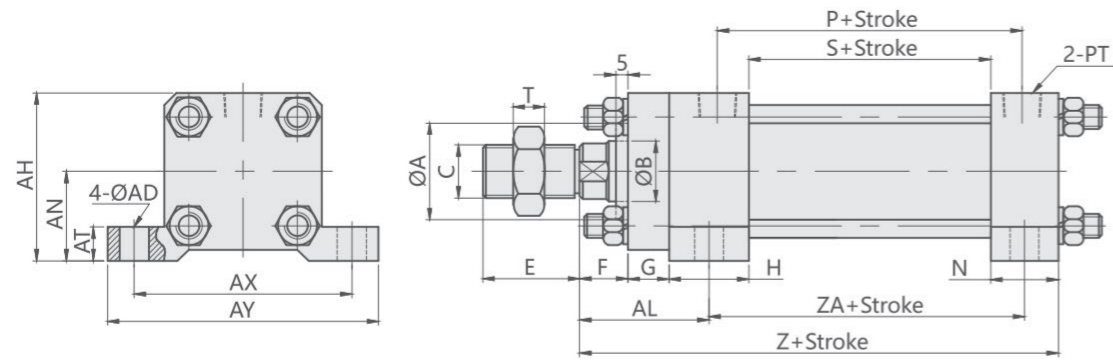

CHOB+LB 前后脚座型 CHOB+LB COURSE OF A TYPE

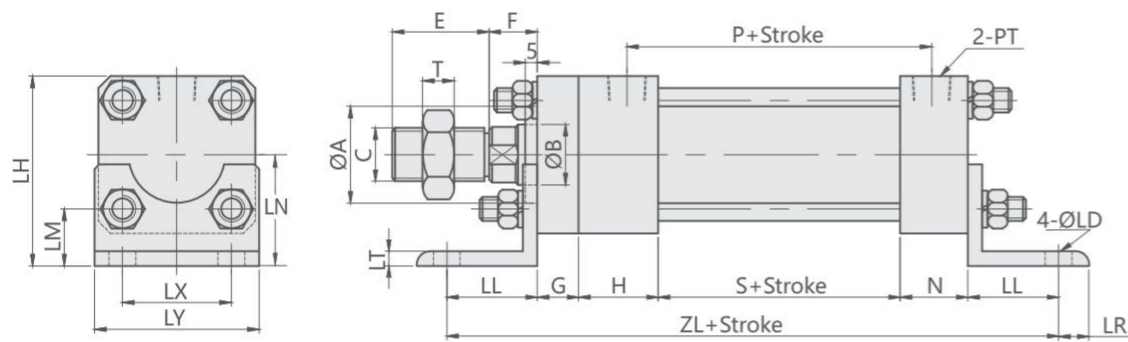

Unit:mm

BORE ΦA ΦB	CHOB TYPE													LA TYPE								LB TYPE									
	C	E	F	G	H	N	P	PT	S	T	ZA	Z	AN	AH	AL	ΦAD	AT	AX	AY	ZL	ΦLD	LL	LM	LR	LT	LX	LY	LH	LN		
Φ40	40	25	M22xP1.5	40	20	17	33	28	76	3/8	50	13	80.5	148	37	69.5	53.5	12	14	90	112	203	11	37.5	23.5	12.5	6	45	68	78.5	46
Φ50	50	30	M26xP1.5	40	20	17	38	30	85	3/8	55	13	89	160	45	85	56	14	17	115	140	224	14	42	26	22	8	56	85	94	54
Φ63	55	35	M30xP1.5	45	20	17	38	30	85	3/8	55	13	89	160	50	95	56	14	19	128	156	228	16	44	26	22	8	62	95	102	57.5
Φ80	60	40	M30xP1.5	45	20	20	38	35	107	1/2	75	13	111.5	188	60	115	59	18	25	152	184	294	18	63	36	27	13	80	120	131	76
Φ100	80	50	M40xP2.0	55	25	20	41	37	123.5	1/2	90	15	129	213	70	135.5	65.5	21	27	178	210	320	20	66	45.5	24	15	100	140	158.5	93
Φ125	90	60	M50xP2.0	70	35	30	57	47	143	3/4	100	15	152	269	90	171	93.5	24	30	230	280	394	24	80	53	30	15	122	169	195	114
Φ150	110	80	M70xP2.0	80	35	30	60	50	135	3/4	90	20	145	265	113	210.5	95	28	35	270	325	390	28	80	53	30	20	144	200	220	125
Φ180	135	100	M90xP2.0	100	35	40	65	55	172	1	120	20	180	315	143	260.5	107	35	45	330	395	460	35	90	62.5	40	20	175	240	267.5	150
Φ200	135	100	M90xP2.0	100	40	40	65	60	175	1	120	20	182.5	325	161	292	112	35	50	360	430	475	35	95	73.5	40	25	193	265	301	170

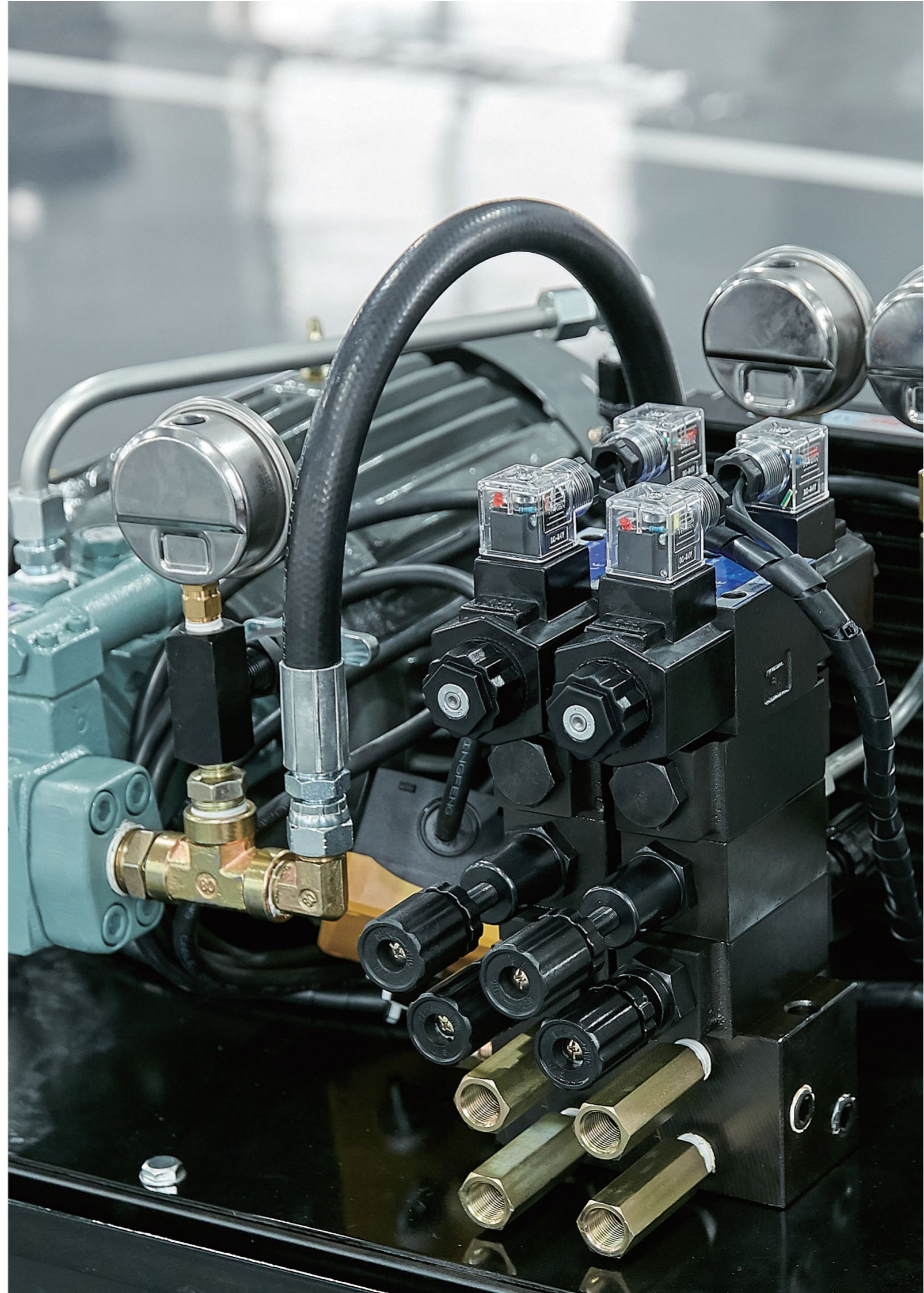

# CFO

## 系列可调缓冲油压缸

### CFO SERIES 14 MPA ADJUSTABLE CUSHIONING HYDRAULIC CYLINDER



#### 可调缓冲油压缸结构图 INSIDE STRUCTURE

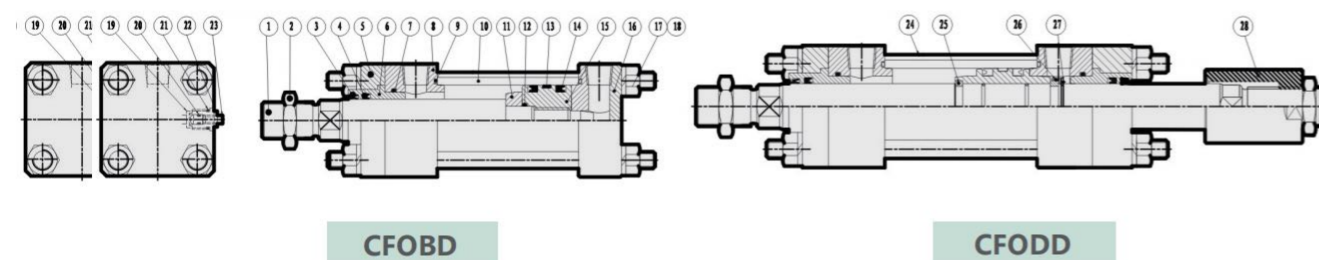

NO	零件名Part name	数量Quantity	NO	零件名Part name	数量Quantity	NO	零件名Part name	数量Quantity
1	活塞杆Piston rod	1	10	缸筒Cylinder tube	1	19	可调螺母Adjustable nut	1
2	锁紧螺母Locking nut	1	11	缓冲套Cushion collar	1	20,21	O型圈Gasket	2
3	防尘油封Dustproof seal	1	12	O型圈Gasket	1	22	六角螺母Hexagon nut	1
4	轴用油封Oil seal for shaft	1	13	耐磨环Wearing ring	1	23	调节丝杆Adjustable lead screw	1
5	压盖Gland	1	14	活塞油封Piston seal	2	24	拉杆Tie rod	4
6	导向套Guide sleeve	1	15	活塞Piston	1	25	半卡环Half snap ring	2
7	O型圈Gasket	1	16	后端盖End cover	1	26	挡环Baffle ring	1
8	前端盖Rod cover	1	17	螺母Nut	8	27	轴用挡圈Rod baffle ring	1
9	O型圈Gasket	2	18	弹性垫圈Spring washer	8	28	可调螺母Adjustable nut	1

#### 可调缓冲油压缸特性资料 Specifications

油缸内径 Hydraulic cylinder inside diameter(mm)	Φ40	Φ50	Φ63	Φ80	Φ100	Φ125
工作流体 Power Fluid	以滤清之标准液压油 Filtered Oil					
缸管材质 Material of cylinder barrel	碳钢管 Carbon steel STKM-13c/白铁管 Stainless tubes SUS 304					
使用压力范围 The range of pressure(MPa)	0.3-14 MPa (3-140kg/cm <sup>2</sup> )					
使用速度范围 The range of speed (mm/sec)	8~300(mm/sec)					
使用温度范围 Range of temperature(°C)	-10 ~ + 60 (°C)					
缓冲行程 Cushion stroke(mm)	25	25	25	25	30	30
标准活塞长度 Length of standard piston (PM)	30	32	36	40	59	59
订制行程于 1501-2500mm 间活塞长度 (PM) Piston length when the stroke is between 1501-2500 mm	60	65	65	80	120	120

#### 订购标示法 ORDERING INDICATION

示例: CFOB-R-D-63/35-100-LB-Y

CFOB	系列 Series	CFOB 标准型 Standard type	CFOD 双轴型 Double Rods type
R	磁性感应 Magnetic	无记号:不附磁石 Blank: No magnet R: 内附磁石 (适用Φ40-Φ100) With magnet	本系列适用Φ40-Φ100 apply to bore Φ40-Φ100
D	固定缓冲型式 Fixed Cushioning Type	无记号:无 Blank: No cushion D: 双侧缓冲 cushions on both ends F: 前盖侧缓冲 cushion on head cover B: 后盖侧缓冲 cushion on end cover	
63	油缸内径 Hydraulic cylinder inside diameter	Φ40 Φ50 Φ63 Φ80 Φ100 Φ125	
35	轴心 Rod	Φ20 Φ30 Φ35 Φ40 Φ50 Φ60 无记号:标准轴心 Blank: standard rod	
100	行程 Stroke	钢管 Steel barrel (Φ40-Φ200) 白钢管 Iron barrel (Φ40-Φ100) 标准行程 Standard stroke: 50, 100, 150, 200, 250, 300, 350, 400, 450, 500, 600, 700, 800, 900, 1000.	最大行程: 4米 Max:4m 最大行程: 2.8米 Max:2.8m
LB	缸体固定型式 Accessories for body	FA 前法兰型 Front flange type FB 后法兰型 Rear flange type LB 脚座型 Foot type CB 双耳环型 Double trunnion type CBP CB 附 Pin CB with pin	LA 脚座型 Foot type TC 耳轴型 Trunnion type CA 单耳型 Single trunnion type CAB CA+P+CB
Y	轴心固定型式 Accessories for rod	Y Y型接头 Y joint YP Y+Pin Y with pin I I型接头 I joint KG 浮动接头 Floating joint	PHS 鱼眼接头 Rod-eye joint T T型接头 T joint H 焊套接头 Welding sleeve joint A 可调螺帽 Adjustable nut

### 标准 CFOBD+FA型 前法兰型 Front Flange Mounting Type

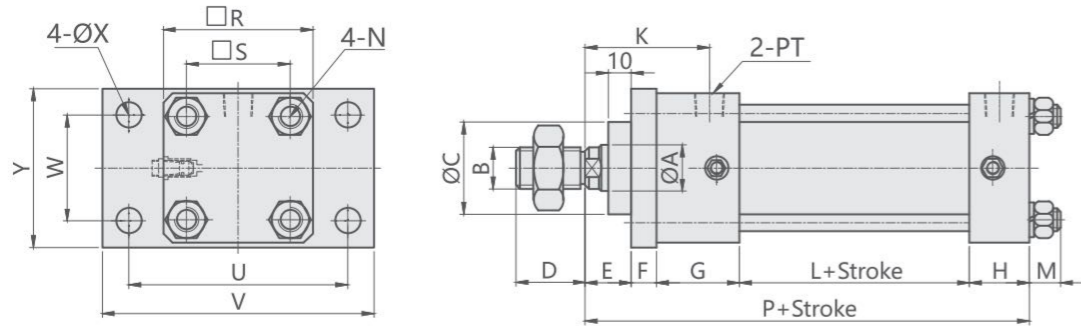

Unit:mm

本体尺寸dimensions													安装相关尺寸mounting dimensions									
BORE	A	B	D	E	F	G	H	K	L	M	N	P	R	S	PT	I	C	U	V	W	X	Y
Φ40	20	M18x1.5	30	20	11	36	26	54	50	13	M10x1.5	143	65	45	1/4"	11	40	95	118	46	11	69
Φ50	30	M26x1.5	35	30	13	42	34	68	50	13	M10x1.5	169	75	52	3/8"	13	45	115	145	58	13	85
Φ63	35	M30x1.5	40	35	15	42	34	75	50	15	M12x1.75	176	90	63	3/8"	15	55	132	165	69	15	98
Φ80	40	M35x1.5	45	35	18	46	40	79	50	17	M16x1.5	189	110	80	1/2"	18	55	155	190	87	18	118
Φ100	50	M45x1.5	55	40	20	50	40	90	69	19	M18x1.5	219	135	98	1/2"	20	65	185	224	109	20	145
Φ125	60	M50x2.0	65	45	24	58	48	104	69	21	M22x1.5	244	165	122	3/4"	24	75	224	272	132	24	175

### 标准 CFOBD+FB型 后法兰型 Rear Flange Mounting Type

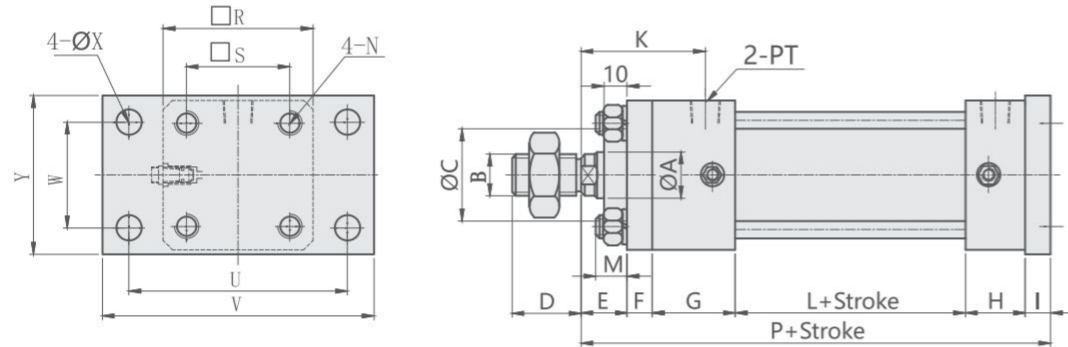

Unit:mm

本体尺寸dimensions													安装相关尺寸mounting dimensions									
BORE	A	B	D	E	F	G	H	K	L	M	N	C	R	S	PT	I	P	U	V	W	X	Y
Φ40	20	M18x1.5	30	20	11	36	26	54	50	13	M10x1.5	40	65	45	1/4"	11	154	95	118	46	11	69
Φ50	30	M26x1.5	35	30	13	42	34	68	50	13	M10x1.5	45	75	52	3/8"	13	182	115	145	58	13	85
Φ63	35	M30x1.5	40	35	15	42	34	75	50	15	M12x1.75	55	90	63	3/8"	15	191	132	165	69	15	98
Φ80	40	M35x1.5	45	35	18	46	40	79	50	17	M16x1.5	55	110	80	1/2"	18	207	155	190	87	18	118
Φ100	50	M45x1.5	55	40	20	50	40	90	69	19	M18x1.5	65	135	98	1/2"	20	239	185	224	109	20	145
Φ125	60	M50x2.0	65	45	24	58	48	104	69	21	M22x1.5	75	165	122	3/4"	24	268	224	272	132	24	175

#### 注意事项

- 1.轴心加大如未注明长度尺寸时,依照本公司规定自行加工。
- 2.CFO系列行程未超过1500mm时,活塞长度(PM)如附表,订制行程如超过1500mm时,活塞长度参阅特性资料表。
- 3.本系列行程超过2000mm(含)时,须加拉杆中间固定座。
- 4.本系列轴心螺帽规格M50mm(含)以上时,其外径为圆形。
- 5.AST为客户指定之可调行程。

#### NOTE

- 1.For axis extending processing,if the length is not specified,then it should follow our company's stipulation for processing.
2. For the CFO series whose stroke is less than 1500mm,the length of the piston is shown in the affiliated table,for those customized CFO whose stroke is more than 1500mm,the length of piston conforms to product specification.
3. Middle rod holder must be installed for those series whose stroke is equal to or more than 2000mm.
- 4.The external diameter would be round when the size of rod nut is equal to or more than M50mm.
- 5.AST stands for the adjustable stroke designated by customers.

### 标准 CFOBD+LA型 左右脚座型 Right & Left Foot Mounting Type

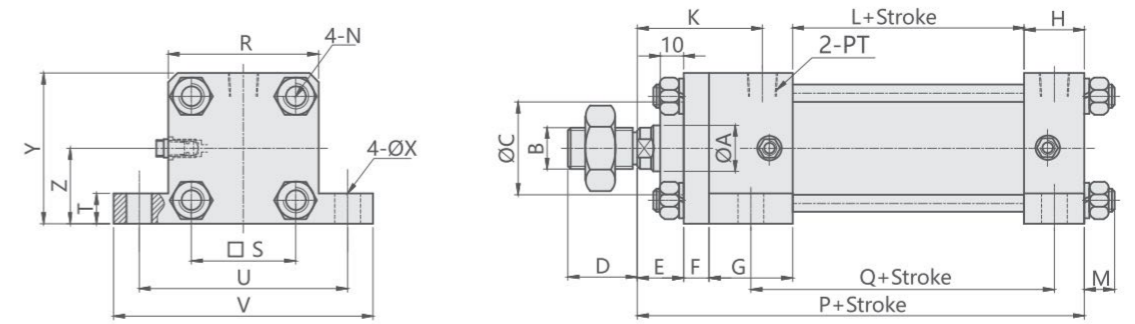

Unit:mm

本体尺寸dimensions													安装相关尺寸mounting dimensions										
BORE	A	B	D	E	F	G	H	K	L	M	N	C	R	S	PT	P	Q	T	U	V	X	Y	Z
Φ40	20	M18x1.5	30	20	11	36	26	54	50	13	M10x1.5	40	65	45	1/4"	143	81	13	90	112	11	65	32.5
Φ50	30	M26x1.5	35	30	13	42	34	68	50	13	M10x1.5	45	75	52	3/8"	169	88	15	109	132	13	75	37.5
Φ63	35	M30x1.5	40	35	15	42	34	75	50	15	M12x1.75	55	90	63	3/8"	176	88	18	128	154	15	90	45
Φ80	40	M35x1.5	45	35	18	46	40	79	50	17	M16x1.5	55	110	80	1/2"	189	93	20	152	184	18	110	55
Φ100	50	M45x1.5	55	40	20	50	40	90	69	19	M18x1.5	65	135	98	1/2"	219	114	24	178	210	20	135	67.5
Φ125	60	M50x2.0	65	45	24	58	48	104	69	21	M22x1.5	75	165	122	3/4"	244	122	28	211	250	24	165	82.5

### 标准 CFOBD+LB型 前后脚座型 Front & Rear Foot Mounting Type

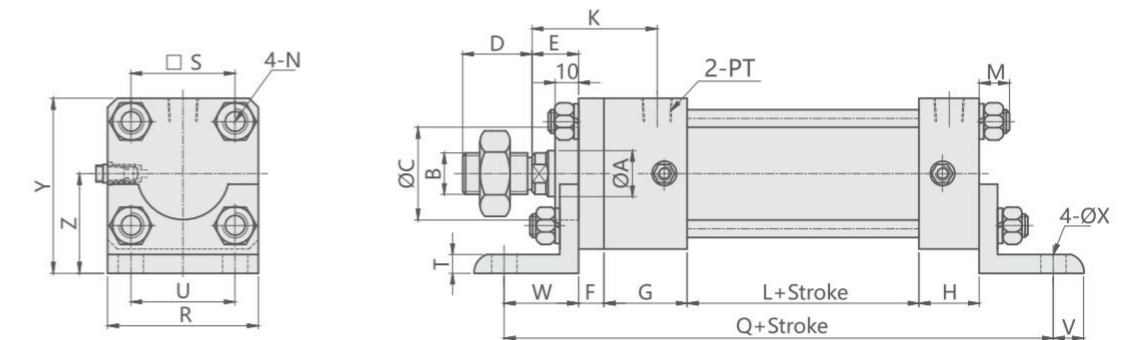

Unit:mm

本体尺寸dimensions													安装相关尺寸mounting dimensions										
BORE	A	B	D	E	F	G	H	K	L	M	N	C	R	S	PT	Q	T	U	V	W	X	Y	Z
Φ40	20	M18x1.5	30	20	11	36	26	54	50	13	M10x1.5	40	65	45	1/4"	187	8	45	13	32	11	75.5	43
Φ50	30	M26x1.5	35	30	13	42	34	68	50	13	M10x1.5	45	75	52	3/8"	209	8	52	15	35	13	87.5	50
Φ63	35	M30x1.5	40	35	15	42	34	75	50	15	M12x1.75	55	90	63	3/8"	225	10	63	18	42	15	105	60
Φ80	40	M35x1.5	45	35	18	46	40	79	50	17	M16x1.5	55	110	80	1/2"	254	12	80	20	50	18	127	72
Φ100	50	M45x1.5	55	40	20	50	40	90	69	19	M18x1.5	65	135	98	1/2"	289	12	98	23	55	20	152.5	85
Φ125	60	M50x2.0	65	45	24	58	48	104	69	21	M22x1.5	75	165	122	3/4"	331	15	122	29	66	24	187.5	105

### 标准 CFOBD+CA型 单耳型 Single Trunion Mounting Type

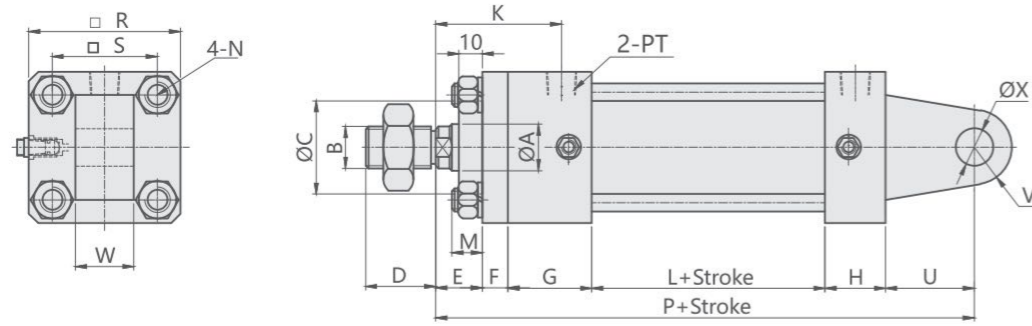

Unit:mm

本体尺寸dimensions													安装相关尺寸mounting dimensions						
BORE	A	B	D	E	F	G	H	K	L	M	N	R	S	PT	P	U	V	W	X
Φ40	20	M18x1.5	30	20	11	36	26	54	50	13	M10x1.5	65	45	1/4"	181	38	16	25	16
Φ50	30	M26x1.5	35	30	13	42	34	68	50	13	M10x1.5	75	52	3/8"	214	45	20	31.5	20
Φ63	35	M30x1.5	40	35	15	42	34	75	50	15	M12x1.75	90	63	3/8"	239	63	31.5	40	31.5
Φ80	40	M35x1.5	45	35	18	46	40	79	50	17	M16x1.5	110	80	1/2"	261	72	31.5	40	31.5
Φ100	50	M45x1.5	55	40	20	50	40	90	69	19	M18x1.5	135	98	1/2"	303	84	40	50	40
Φ125	60	M50x2.0	65	45	24	58	48	104	69	21	M22x1.5	165	122	3/4"	307	63	50	53	50

### 标准 CFOBD+TC型 耳轴型 Trunion Mounting Type

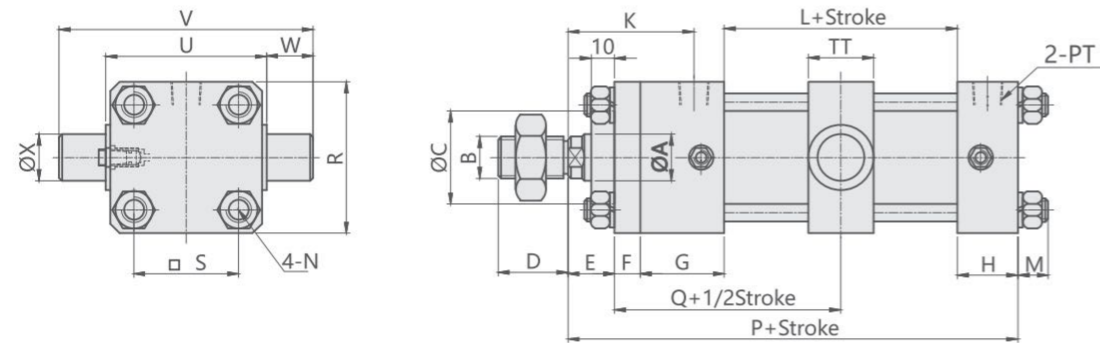

Unit:mm

本体尺寸dimensions													安装相关尺寸mounting dimensions								
BORE	A	B	D	E	F	G	H	K	L	M	N	R	S	PT	P	Q	U	V	W	X	TT
Φ40	20	M18x1.5	30	20	11	36	26	54	50	13	M10x1.5	65	45	1/4"	143	72	69	109	20	20	28
Φ50	30	M26x1.5	35	30	13	42	34	68	50	13	M10x1.5	75	52	3/8"	169	80	85	135	25	25	33
Φ63	35	M30x1.5	40	35	15	42	34	75	50	15	M12x1.75	90	63	3/8"	176	82	98	161	31.5	31.5	40
Φ80	40	M35x1.5	45	35	18	46	40	79	50	17	M16x1.5	110	80	1/2"	189	89	118	181	31.5	31.5	43
Φ100	50	M45x1.5	55	40	20	50	40	90	69	19	M18x1.5	135	98	1/2"	219	104.5	145	225	40	40	53
Φ125	60	M50x2.0	65	45	24	58	48	104	69	21	M22x1.5	165	122	3/4"	244	116.5	175	275	50	50	58

#### 注意事项

1. 轴心加大或缩小时如未注明长度尺寸时, 依照本公司规定自行加工
2. CFO40系列行程超过500mm以上时, 轴心牙加大为M18xP1.5。
3. CFO系列行程未超过1499mm时, 活塞长度(PM)依据表组装, 行程如超过1500mm以上时, 活塞长度(PM)请参阅特性资料表。
4. 前盖螺帽(ΦJ)与轴心螺帽(W)规格大于M50时, 其外径为圆型W, J指其外径。
5. AST为客户指定之可调行程。

#### NOTE

1. For rods extending or reducing processing, if the length is not specified, then it should follow our company's stipulation for processing.
2. Rod thread tooth should be extending into M18\*P1.5 for CFO series bore size 40 whose stroke is more than 500mm.
3. For the CFO series whose stroke is not exceeding 1499mm, the length of piston conforms to specification table for assembling. For those whose stroke is more than 1500mm, the length of piston conforms to characteristics table.
4. The external diameter should be round when the size of rod cover nut (ΦJ) and rod nut (ΦW) is more than M50, WJ refer to its external diameter.
5. AST stands for adjustable stroke designated by customers.

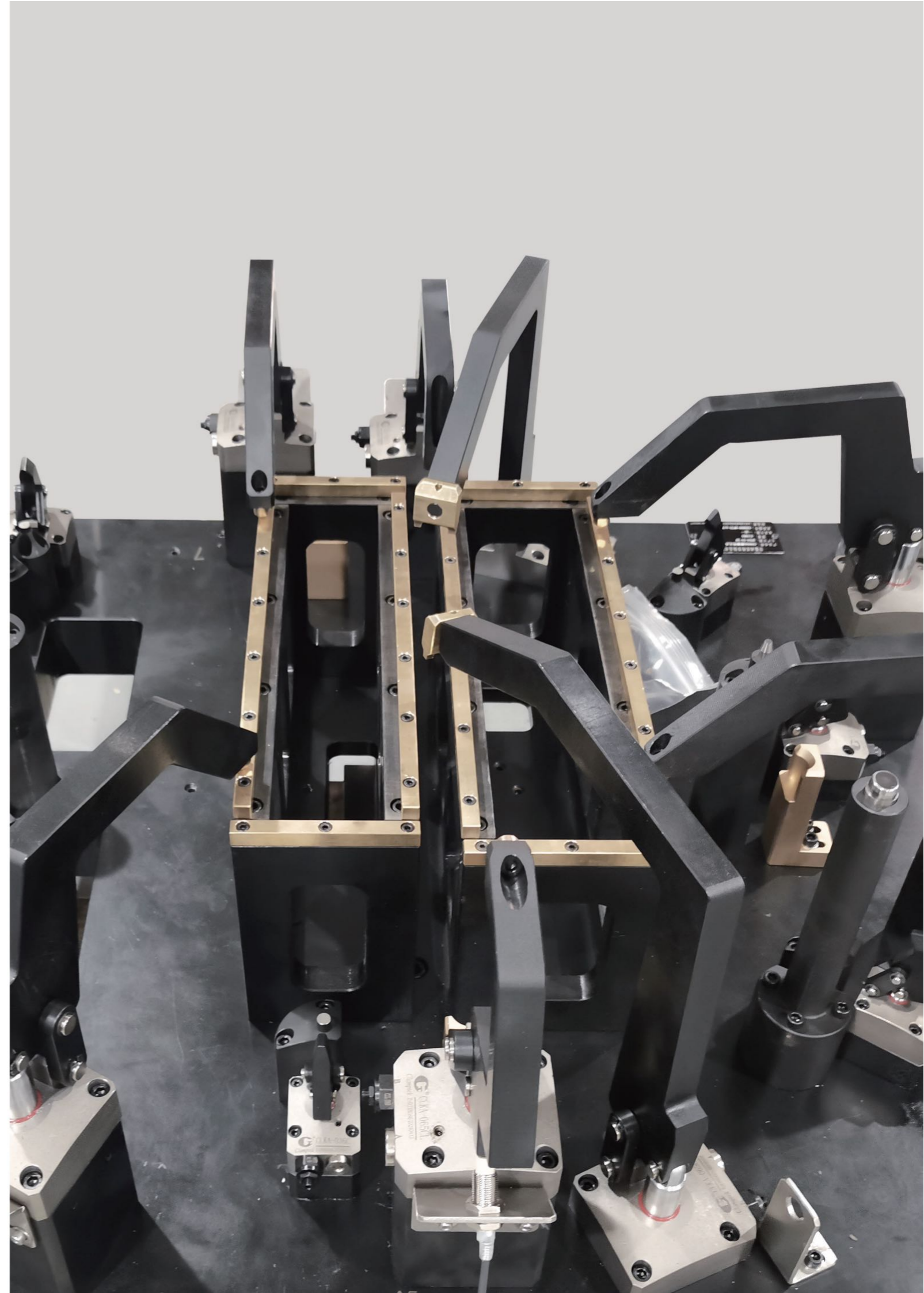

# CRO

## 系列圆型油压缸

# CRO SERIES 14 MPA ROUND HYDRAULIC CYLINDER



### 圆型油压缸结构图 INSIDE STRUCTURE

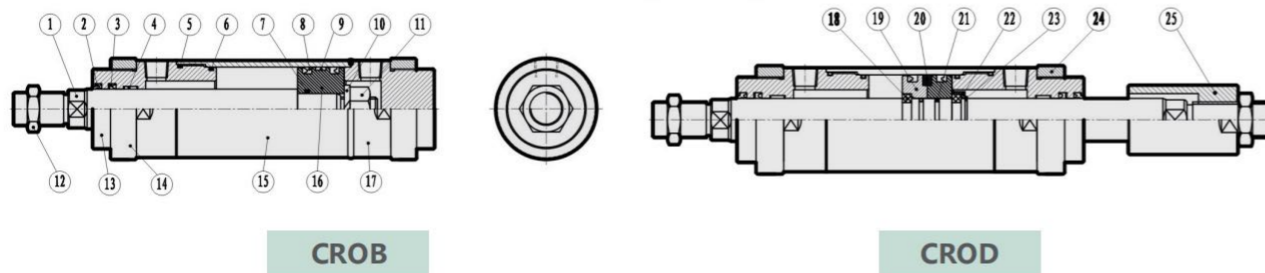

NO	零件名 Part name	数量 Quantity	NO	零件名 Part name	数量 Quantity	NO	零件名 Part name	数量 Quantity
1	活塞杆Piston rod	1	10	弹性垫卷Spring washer	2	18	半卡环 Half snap ring	2
2	防尘油封Dustproof seal	1	11	螺母 Nut	1	19	铜活塞 Copper piston	1
3	轴用油封Oil seal for shaft	1	12	轴心螺母Rod nut	1	20	磁环 Magnet Ring	1
4	导向带 Guidance tape	1	13	前端盖 Rod cover	1	21	O型圈 Gasket	1
5	O型环 Gasket	1	14	锁紧螺母 Lock Nut	1	22	挡环 Baffle Ring	1
6	O型环 Gasket	1	15	缸筒 Cylinder tube	1	23	轴用挡圈 Washer On Shaft	1
7	O型环 Gasket	1	16	活塞 Piston	1	24	锁紧螺母 Lock Nut	1
8	活塞油封 Piston seal	2	17	后端盖 End cover	1	25	可调螺母 Adjustable Nut	1
9	耐磨环 Wearing ring	1						

### 可调缓冲油压缸特性资料 Specifications

油缸内径Hydraulic cylinder inside diameter(mm)	Φ40	Φ50	Φ63	Φ80	Φ100	Φ125
工作流体 Power Fluid	以滤清之标准液压油 Filtered Oil					
缸管材质 Material of cylinder barrel	碳钢管 Carbon steel STKM-13c/白铁管Stainless tubes SUS 304					
使用压力范围 The range of pressure(MPa)	0.3-14 MPa (3-140kg/cm <sup>2</sup> )					
使用速度范围 The range of speed (mm/sec)	8~300(mm/sec)					
使用温度范围 Range of temperature(°C)	-10 ~ + 60 (°C)					
标准活塞长度 Length of standard piston (PM)	30	35	35	50	60	70
订制行程于1501-2500mm间活塞长度 (PM) Piston length when the stroke is between 1501-2500 mm	60	70	70	100	100	120
订制行程于2501-4000mm间活塞长度 (PM) Piston length when the stroke is between 2501-4000 mm	90	100	100	150	180	200

### 订购标示法 ORDERING INDICATION

示例: CROB-R-D-63/35-100-LB-Y

CROB	型式 Type	CROA(平尾型) Flat tail type	CROB(B型) B type	CROC(CA型) CA type	CROD(双轴型) Double rods
R	磁性感应 Magnetic	无记号: 不附磁石 Blank: No magnet R: 内附磁石 (适用Φ40-Φ100) With magnet			本系列适用Φ40-Φ100 apply to bore Φ40-Φ100
D	固定缓冲型式 Fixed Cushioning Type	无记号:无 Blank: No cushion D: 双侧缓冲 cushions on both ends F:前盖侧缓冲 cushion on head cover B: 后盖侧缓冲 cushion on end cover			
63	油缸内径 Hydraulic cylinder inside diameter		Φ40 Φ50 Φ63 Φ80 Φ100 Φ125		
35	轴心 Rod	标准Standard 最大Max 无记号:标准轴心 Blank: standard rod	Φ20 Φ25 Φ35 Φ40 Φ50 Φ60 Φ25 Φ30 Φ40 Φ50 Φ70 Φ80		
100	行程 Stroke	钢管Steel barrel (Φ40-Φ200) 白钢管Iron barrel (Φ40-Φ200)		最大行程: 4米 Max:4m 最大行程: 2.8米 Max:2.8m	
LB	缸体固定型式 Accessories for body	FA前法兰型 Front flange type		LA 脚座型 Foot type	
		FB后法兰型 Rear flange type		TC 耳轴型 Trunnion type	
Y	轴心固定型式 Accessories for rod	Y Y型接头 Y joint		PHS 鱼眼接头 Rod-eye joint	
		YP Y+Pin Y with pin		T T型接头 T joint	
		I I型接头 I joint		H 焊套接头 Welding sleeve joint	
		KG 浮动接头 Floating joint		A 可调螺帽 Adjustable nut	

### CROB 标准型 CROB STANDARD TYPE

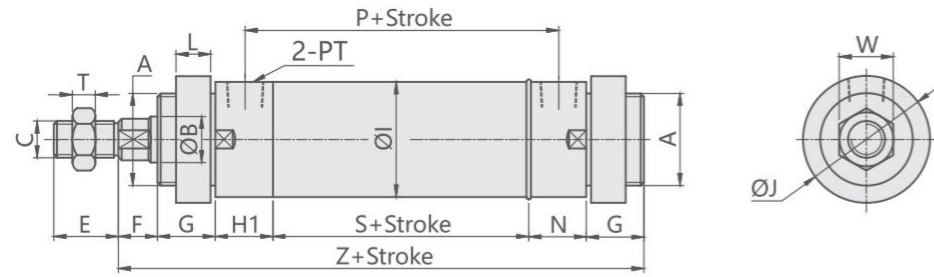

### CROA+FA 前法兰型 CROA+FA FRONT FLANGE TYPE

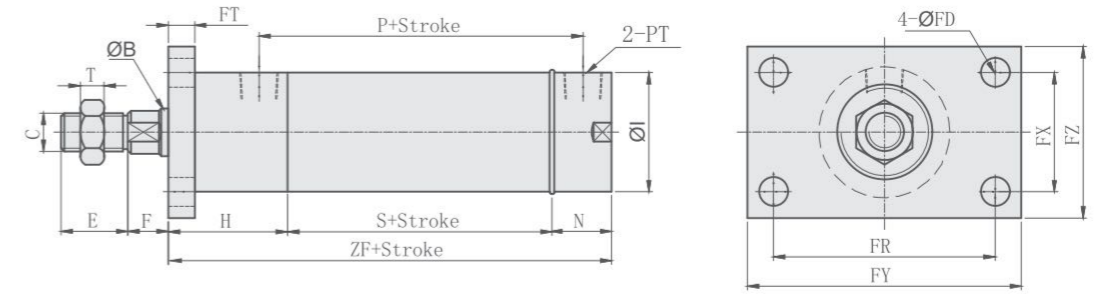

### CROD 标准型 CROB STANDARD TYPE

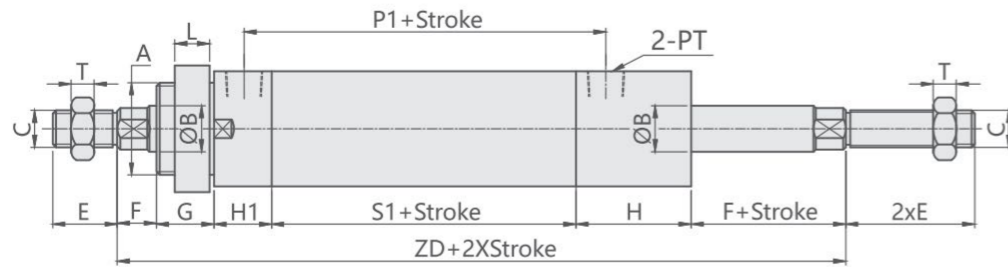

### CROB+FB 后法兰型 CROB+FB REAR FLANGE TYPE

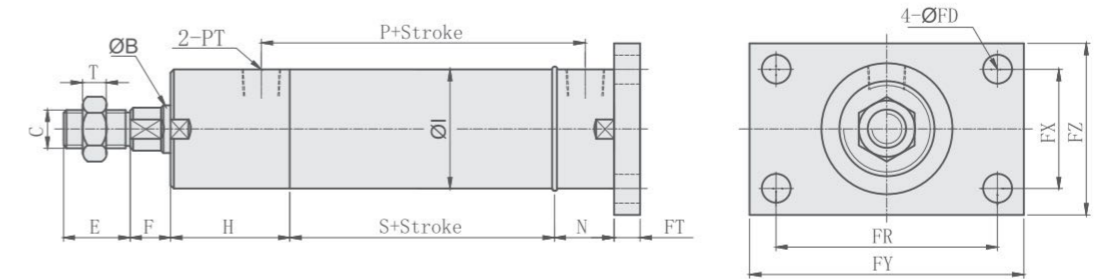

### CROD-A 双轴可调型 CROD-A ADJUSTABLE DOUBLE-END ROD TYPE

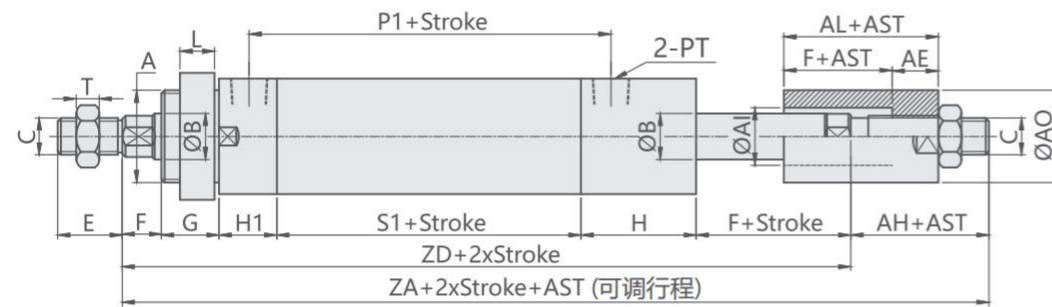

### CROD+FA 双轴前法兰型 CROD + FA DOUBLE END FRONT FLANGE TYPE

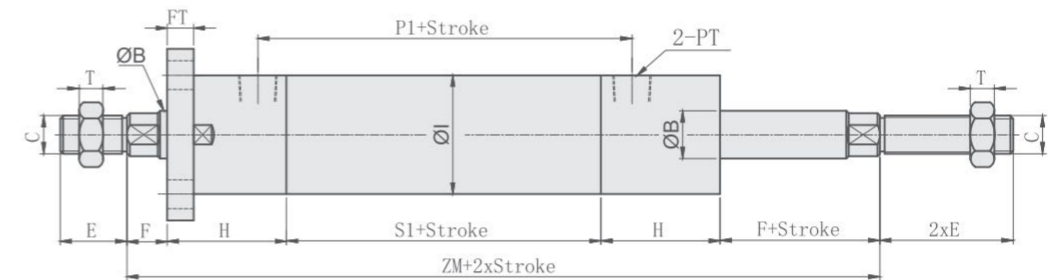

Unit:mm

CROB-CROD TYPE																			A(可调行程)TYPE								
BORE	A	ΦB	C	E	F	G	H	H1	ΦI	L	N	ΦJ	P	PT	S	W	T	Z	P1	S1	ZA	ZD	AH	AE	ΦAI	ΦAO	AL
Φ40	M40XP2.0	20	M16XP1.5	28	17	25	50	25	50	15	25	55	86	3/8"	61	23.5	8	178	107	82	246	216	30	20	25	40	37
Φ50	M50XP2.0	25	M22XP1.5	40	20	25	50	25	60	15	30	65	96	3/8"	66	32	13	191	112	87	267	227	40	25	35	50	45
Φ63	M60XP2.0	35	M30XP1.5	45	20	30	50	30	73	20	35	80	105	3/8"	70	41	13	215	125	95	295	255	40	25	45	60	45
Φ80	M70XP2.0	40	M30XP1.5	45	20	30	60	30	95	20	40	90	127.5	1/2"	90	41	13	240	150	120	325	280	45	30	50	70	50
Φ100	M90XP2.0	50	M40XP2.0	55	25	30	60	30	114	20	40	110	147.5	1/2"	110	55	15	265	180	150	365	320	45	30	60	90	55
Φ125	M120XP2.0	60	M50XP2.0	70	30	30	70	40	145	20	50	150	172.5	3/4"	125	65	15	305	210	170	420	370	50	35	70	100	65

#### 注意事项

- 1.轴心加大或缩小时如未注明长度尺寸时, 依照本公司规定自行加工。
- 2.CRO系列行程未超过1499mm时, 活塞长度(PM)依据表组装, 行程如超过1500mm以上时, 活塞长度(PM)请参阅特性资料表。
- 3.前盖螺帽(中)与轴心螺帽(W)规格大于M50时, 其外径为圆形W指其外径。
- 4.AST为客户指定之可调行程。

#### NOTE

1. For rods extending or reducing processing,if the length is not specified,then it should follow our company's stipulation for processing.
2. For the CRO series whose stroke is not exceeding 1499mm,the length of piston conforms to specification table for assembling,For those whose stroke is more than 1500mm,the length of piston conforms to characteristics table.
3. The external diameter should be round when the size of rod cover nut(I) and rod nut (W) is more than M50,WJ refer to its external diameter.
- 4.AST stands for adjustable stroke designated by customers.

Unit:mm

CROA-CROB-CROD TYPE																FA-FB TYPE					
BORE	ΦB	C	E	F	H	P1	ΦI	N	P	PT	S	T	S1	ZF	ZM	ΦFD	FT	FR	FX	FY	FZ
Φ40	20	M16XP1.5	28	17	50	107	50	25	86	3/8"	61	8	82	136	199	12	11	93	50	115	72
Φ50	25	M22XP1.5	40	20	50	112	60	30	96	3/8"	66	13	87	146	207	14	17	110	56	150	85
Φ63	35	M30XP1.5	45	20	60	125	73	35	105	3/8"	70	13	95	165	235	14	17	126	68	155	95
Φ80	40	M30XP1.5	45	20	60	150	95	40	127.5	1/2"	90	13	120	190	260	18	20	152	75	190	120
Φ100	50	M40XP2.0	55	25	60	180	114	40	147.5	1/2"	110	15	150	210	295	20	20	180	100	220	140
Φ125	60	M50XP2.0	70	30	70	210	145	50	172.5	3/4"	125	15	170	245	340	24	30	222	122	280	170

#### 注意事项

- 1.轴心加大或缩小时如未注明长度尺寸时, 依照本公司规定自行加工。
- 2.CRO系列行程未超过1499mm时, 活塞长度(PM)依据表组装, 行程如过1500mm以上时, 活塞长度(PM)请参阅特性资料表。
- 3.前盖螺帽(中)与轴心螺帽(W)规格大于M50时, 其外径为圆形W指其外径。
- 4.AST为客户指定之可调行程

#### NOTE

1. For rods extending or reducing processing,if the length is not specified,then it should follow our company's stipulation for processing.
2. For the CRO series whose stroke is not exceeding 1499mm,the length of piston conforms to specification table for assembling,For those whose stroke is more than 1500mm,the length of piston conforms to characteristics table.
3. The external diameter should be round when the size of rod cover nut (ΦJ) and rod nut (ΦW) is more than M50,WJ refer to its external diameter.
4. AST stands for adjustable stroke designated by customers.

### CRO+CA 单耳环型 CRO+CA SINGLE TRUNNION TYPE

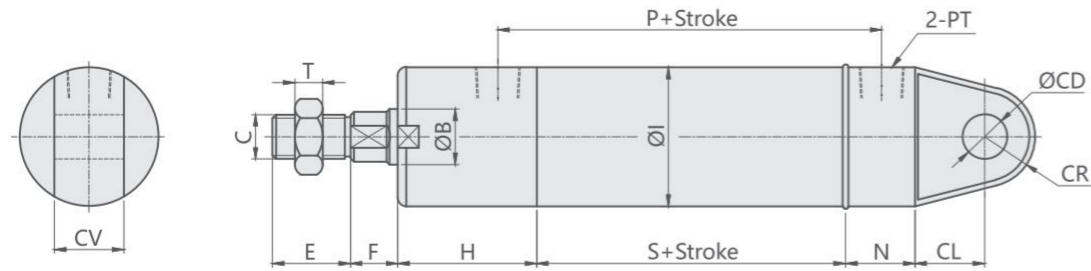

### CROB+LB 前后脚座型 CROB+LB FOOT MOUNT TYPE

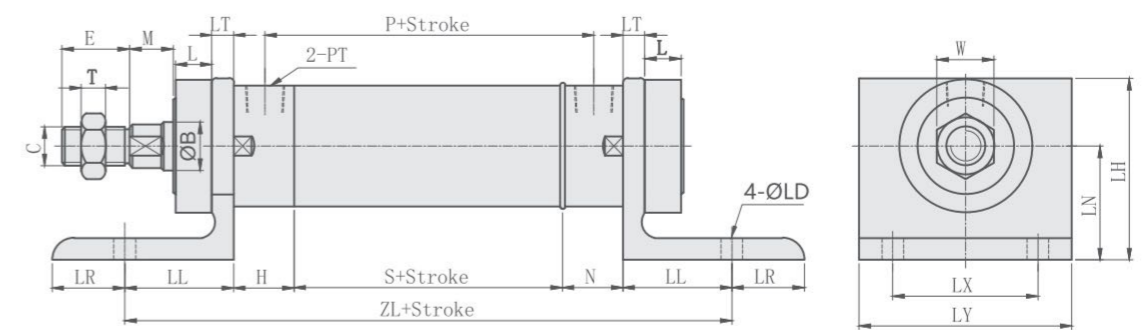

### CRO+CB 双耳环型 CRO+CB DOUBLE TRUNNION TYPE

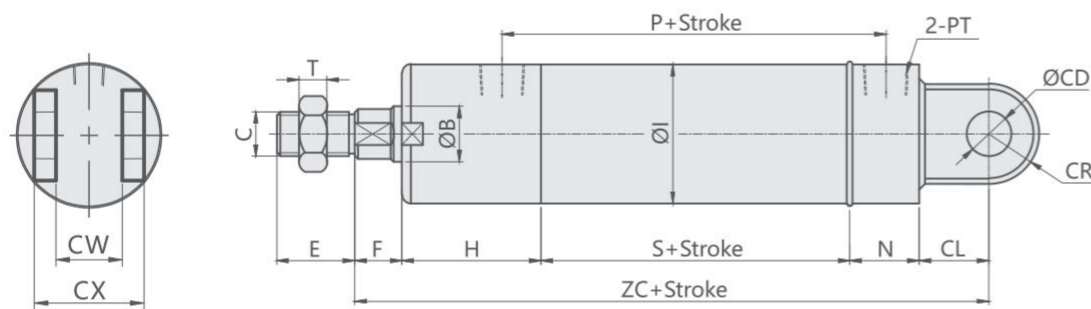

### CROA+TC 中间耳轴型 CROA+TC MIDDLE TRUNNION TYPE

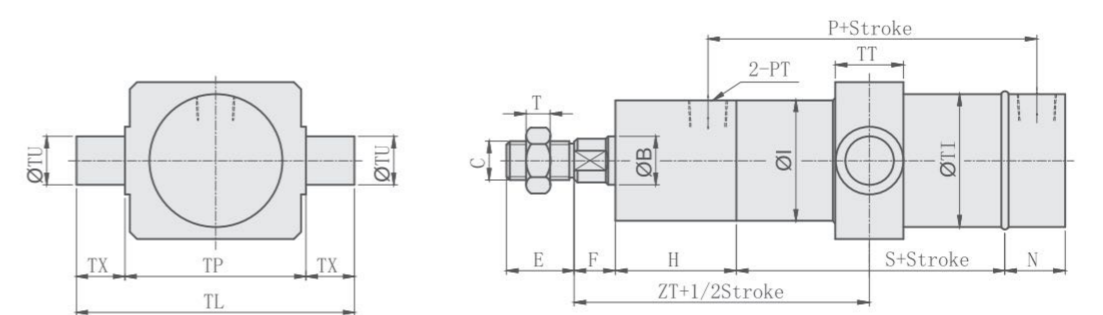

Unit:mm

CRO TYPE														CA,CB TYPE					
BORE	ΦB	C	E	F	H	ΦI	N	P	PM	PT	S	T	ZC	CW	CL	ΦCD	CR	CV	CX
Φ40	20	M16XP1.5	28	17	50	50	25	88	30	3/8"	61	8	178	26	25	16	18	25	41
Φ50	25	M22XP1.5	40	20	50	60	30	96	35	3/8"	66	13	201	26	35	20	25	25	46
Φ63	35	M30XP1.5	45	20	60	73	35	105	35	3/8"	70	13	230	31	45	25	30	30	56
Φ80	40	M30XP1.5	45	20	60	95	40	127.5	50	1/2"	90	13	260	36	50	30	30	35	66
Φ100	50	M40XP2.0	55	25	60	114	40	147.5	60	1/2"	110	15	295	41	60	35	35	40	81
Φ125	60	M50XP2.0	70	30	70	145	50	172.5	70	3/4"	125	15	345	56	70	50	50	55	106

#### 注意事项

- 1.轴心加大或缩小时如未注明长度尺寸时, 依照本公司规定自行加工。
- 2.CRO系列行程未超过1499mm时, 活塞长度(PM)依据表组装, 行程如超过1500mm时, 活塞长度(PM)请参阅特性资料表。
- 3.前盖螺帽(ΦI)与轴心螺帽(W)规格大于M50时, 其外径为圆形,W指其外径。
- 4.AST为客户指定之可调行程。

#### NOTE

1. For rods extending or reducing processing,if the length is not specified,then it should follow our company's stipulation for processing.
2. For the CRO series whose stroke is not exceeding 1499mm,the length of piston conforms to specification table for assembling,For those whose stroke is more than 1500mm,the length of piston conforms to characteristics table.
3. The external diameter should be round when the size of rod cover nut (ΦI) and rod nut (ΦW) is more than M50,WJ refer to its external diameter.
- 4.AST stands for adjustable stroke designated by customers.

Unit:mm

CROA-CROB TYPE														LB TYPE						TC TYPE										
BORE	ΦB	C	E	M	H	N	L	P	PT	S	T	ZL	ΦLD	LH	LN	LL	LR	LT	LX	LY	ZT	F	H	ΦI	ΦTI	ΦTU	TL	TP	TT	TX
Φ40	20	M16XP1.5	28	18	25	25	15	86	3/8"	61	8	201	12	75	47	45	30	9	60	88	97.5	17	50	50	55	20	115	75	28	20
Φ50	25	M22XP1.5	40	18	25	30	15	96	3/8"	66	13	231	14	88	57	55	33	9	70	100	103	20	50	60	65	25	140	90	33	25
Φ63	35	M30XP1.5	45	17	30	35	20	105	3/8"	70	13	271	16	101	63	68	33	13	70	124	115	20	60	76	83	32	166	102	40	32
Φ80	40	M30XP1.5	45	17	30	40	20	127.5	1/2"	90	13	296	18	101	60	68	33	13	80	140	125	20	60	95	102	32	184	120	43	32
Φ100	50	M40XP2.0	55	20	30	40	20	147.5	1/2"	110	15	320	28	140	80	70	35	15	90	144	140	25	60	114	120	40	220	140	53	40
Φ125	60	M50XP2.0	70	25	40	50	20	172.5	3/4"	125	15	375	22	190	110	80	40	20	120	160	162.5	30	70	145	150	50	275	175	58	50

#### 注意事项

- 1.轴心加大或缩小时如未注明长度尺寸时, 依照本公司规定自行加工。
- 2.CRO系列行程未超过1499mm时, 活塞长度(PM)依据表组装, 行程如超过1500mm时, 活塞长度(PM)请参阅特性资料表。
- 3.前盖螺帽(ΦI)与轴心螺帽(W)规格大于M50时, 其外径为圆形,W指其外径。
- 4.AST为客户指定之可调行程。

#### NOTE

1. For rods extending or reducing processing,if the length is not specified,then it should follow our company's stipulation for processing.
2. For the CRO series whose stroke is not exceeding 1499mm,the length of piston conforms to specification table for assembling,For those whose stroke is more than 1500mm,the length of piston conforms to characteristics table.
3. The external diameter should be round when the size of rod cover nut (ΦI) and rod nut (ΦW) is more than M50,WJ refer to its external diameter.
- 4.AST stands for adjustable stroke designated by customers.

# CMO/CHO/CRO/CFO

油压缸轴心配件

## CMO/CHO/CRO/CFO HYDRAULIC CYLINDER AXIS ACCESSORIES

Y型接头 Y CONNECTORS

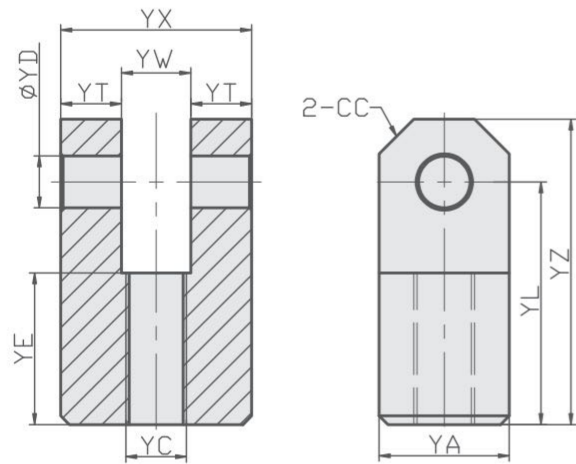

I型接头 I CONNECTORS

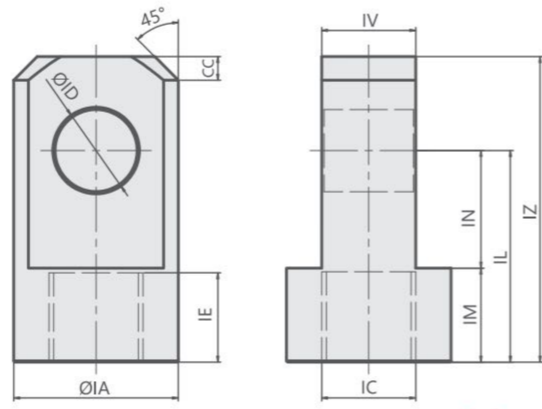

Unit:mm

Y型接头 ROD CLEVIS										MATERIAL : 45 #
TYPE	YA	YC	YD	YE	YL	YT	YW	YX	YZ	CC
MY-014	30	M14x1.5	12	35	56	14	16	44	70	8
MY-016	30	M16x1.5	12	35	56	14	16	44	70	8
MY-018	30	M18x1.5	12	35	56	14	16	44	70	8
MY-022	45	M22x1.5	20	35	70	14	24	52	93	10
MY-026	50	M26x1.5	20	35	70	15	28	58	96	10
MY-030	55	M30x1.5	20	41	80	20	32	72	107	12
MY-030A	55	M30x1.5	25	41	80	22	40	84	107	12
MY-40	70	M40x2.0	35	47	93	20	30	70	127	15
MY-50	80	M40x2.0	40	50	100	22.5	35	80	140	15

Unit:mm

I型接头 I ROD CLEVIS										MATERIAL : 45 #
TYPE	IA	IC	ID	IE	IL	IM	IN	IV	IZ	CC
FI-014	30	M14XP1.5	16	18	37	21	16	15	52	5
FI-016	30	M16XP1.5	16	18	37	21	16	15	52	5
FI-018	32	M18XP1.5	16	23	50	25	25	18	70	8
FI-022	40	M22XP1.5	20	23	55	25	30	20	80	10
FI-026	50	M26XP1.5	25	28	60	30	30	25	90	10
FI-030	60	M30XP1.5	30	32	75	35	40	35	110	10
FI-040	70	M40XP2.0	35	38	90	40	50	40	130	10

T型接头 T CONNECTORS

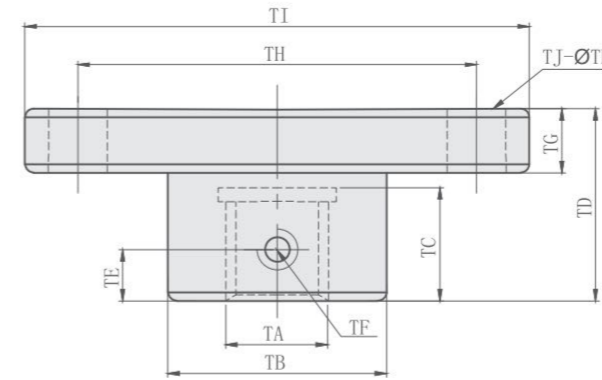

H型焊套接头 H WELDING JOINT

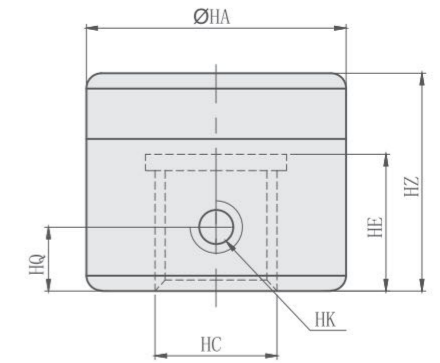

Unit:mm

T型接头 ROD END MOUNTING							MATERIAL : 45 #				
TYPE	TA	TB	TC	TD	TE	TF	TG	TH	TI	TJ	TK
T-010	M10xP1.25	20	20	30	10	M6XP1.0	8	40	60	4	8
T-014	M14xP1.5	30	25	40	12	M8XP1.25	10	55	80	4	10
T-016	M16xP1.5	30	25	40	12	M8XP1.25	10	55	80	4	10
T-018	M18xP1.5	30	25	40	12	M8XP1.25	10	55	80	4	10
T-022	M22xP1.5	35	32	50	15	M8XP1.25	15	65	85	4	10
T-026	M26xP1.5	40	32	50	15	M8XP1.25	15	70	90	4	10
T-030	M30xP1.5	55	35	55	20	M8XP1.25	20	75	100	4	12
T-036	M36xP2.0	50	48	55	20	M8XP1.25	20	80	105	4	12
T-040	M40xP2.0	60	48	65	25	M10XP1.5	25	90	115	6	12
T-045	M45xP2.0	70	55	65	25	M10XP1.5	25	100	125	6	12
T-050	M50xP2.0	80	55	75	25	M10XP1.5	25	110	140	6	14
T-060	M60xP2.0	90	55	80	30	M10XP1.5	30	120	150	6	14
T-070	M70xP2.0	100	65	100	30	M12XP1.75	30	140	180	6	18
T-090	M90xP2.0	140	85	120	40	M12XP1.75	40	180	220	6	18

Unit:mm

H型焊套接头 H ROD END MOUNTING							MATERIAL : 45 #			
TYPE	ΦHA	HC	HE	HK	HQ	HZ				
H-010	20	M10xP1.25	20	M6XP1.0	10	30				
H-014	35	M14xP1.5	25	M8XP1.25	12	40				
H-016	35	M16xP1.5	25	M8XP1.25	12	40				
H-018	35	M18xP1.5	25	M8XP1.25	12	40				
H-022	40	M22xP1.5	32	M8XP1.25	15	50				
H-026	45	M26xP1.5	32	M8XP1.25	15	50				
H-030	50	M30xP1.5	35	M8XP1.25	20	55				
H-036	55	M36xP1.5	40	M8XP1.25	20	60				
H-040	60	M40xP2.0	48	M10XP1.5	25	65				
H-045	70	M45xP2.0	52	M10XP1.5	25	70				
H-050	80	M50xP2.0	55	M10XP1.5	25	75				
H-060	90	M60xP2.0	55	M10XP1.5	30	80				
H-070	100	M70xP2.0	65	M12XP1.75	30	100				
H-090	140	M90xP2.0	85	M12XP1.75	40	120				

# CGO

## 系列重型油压缸

### CGO SERIES 21 MPA TIE-ROD HYDRAULIC CYLINDER



#### 重型油压缸结构图 INSIDE STRUCTURE

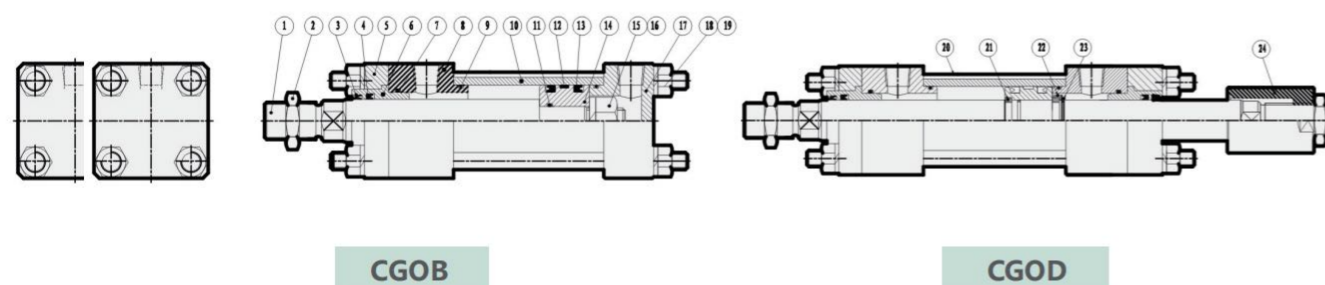

NO	零件名 Part name	数量 Quantity	NO	零件名 Part name	数量 Quantity	NO	零件名 Part name	数量 Quantity
1	活塞杆 Piston rod	1	9	O型圈 Gasket	2	17	后端盖 End cover	1
2	锁紧螺母 Locking nut	1	10	缸筒 Cylinder tube	1	18	螺母 Nut	8
3	防尘油封 Dustproof seal	1	11	O型圈 Gasket	1	19	弹性垫圈 Spring washer	8
4	轴用油封 Oil seal for shaft	1	12	耐磨环 Wearing ring	1	20	拉杆 Tie rod	4
5	压盖 Gland	1	13	活塞油封 Piston seal	2	21	半卡环 Half snap ring	2
6	导向套 Guide sleeve	1	14	活塞 Piston	1	22	挡环 Baffle ring	1
7	O型圈 Gasket	1	15	螺母 Nut	1	23	轴用挡圈 Rod baffle ring	1
8	前段盖 Rod cover	1	16	弹性垫圈 Spring washer	1	24	可调螺母 Adjustable nut	1

#### 重型油压缸特性资料 Specifications

油缸内径 Hydraulic cylinder inside diameter (mm)	Φ40	Φ50	Φ63	Φ80	Φ100	Φ125	Φ140	Φ150	Φ160
工作流体 Power Fluid	以滤清之标准液压油 Filtered Oil								
缸管材质 Material of cylinder barrel	碳钢管 Carbon steel STKM-13c/白铁管 Stainless tubes SUS 304								
使用压力范围 The range of pressure (MPa)	0.3-21 MPa (3-210kg/cm <sup>2</sup> )								
使用速度范围 The range of speed (mm/sec)	8~300 (mm/sec)								
使用温度范围 Range of temperature (°C)	-10 ~ + 60 (°C)								
缓冲行程 Cushion stroke (mm)	25	25	25	25	30	30	30	30	30
标准活塞长度 Length of standard piston (PM)	40	44	51	57	65	71	74	84	92
订制行程于 1501-2500mm 间活塞长度 (PM) Piston length when the stroke is between 1501-2500 mm	80	88	100	110	120	140	140	160	170
订制行程于 2501-4000mm 时活塞长度 (PM) Customized stroke is 2501-4000mm	160	170	200	210	220	250	260	270	270

#### 订购标示法 ORDERING INDICATION

示例: CGOB-D-63/35-100-LB-Y

CGOB	系列 Series	CGOB 标准型 Standard type		CGOD 双轴型 Double Rods type						
D	固定缓冲型式 Fixed Cushioning Type	无记号:无 Blank: No cushion	D: 双侧缓冲 cushions on both ends	F: 前盖侧缓冲 cushion on head cover	B: 后盖侧缓冲 cushion on end cover					
63	油缸内径 Hydraulic cylinder inside diameter	Φ40	Φ50	Φ63	Φ80	Φ100	Φ125	Φ140	Φ150	Φ160
35	轴心 Rod 缓冲用轴心	缓冲用轴心 最大 Max 标准 Standard 无记号:标准轴心 Blank: standard rod	Φ25	Φ30	Φ35	Φ45	Φ50	Φ70	Φ80	Φ90
100	行程 Stroke	钢管 Steel barrel (Φ40-Φ200) 白铁管 Iron barrel (Φ40-Φ200)	最大行程: 4米 Max: 4m	最大行程: 2.8米 Max: 2.8m						
LB	缸体固定型式 Accessories for body	FA 前法兰型 Front flange type		CA 单耳环型 Single trunnion type						
		FB 后法兰型 Rear flange type		CB 双耳环型 Double trunnion type						
		LB 脚座型 Foot mount type		CBP CB 附 PIN CB with PIN						
		TC 耳轴型 Trunnion type		CAB CA+P+CB						
Y	轴心固定型式 Accessories for rod	Y Y型接头 Y joint		PHS 鱼眼接头 Rod-eye joint						
		YP Y+Pin Y with pin		T T型接头 T joint						
		I I型接头 I joint		H 焊套接头 Welding sleeve joint						
		KG 浮动接头 Floating joint		A 可调螺帽 Adjustable nut						

### 标准 CGOB 标准型 Single Rod Type

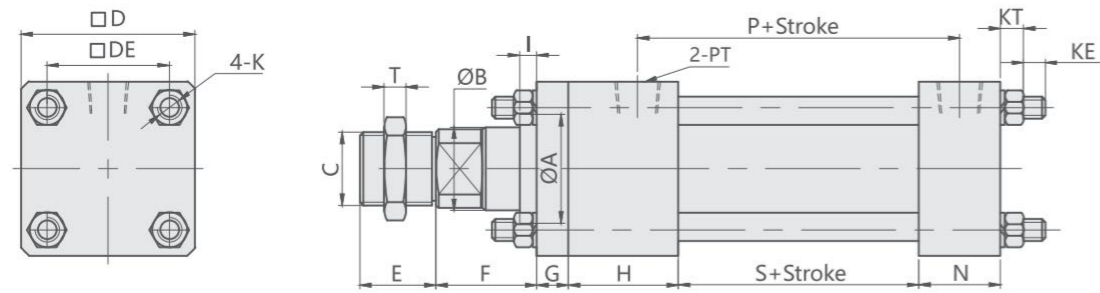

Unit:mm

BORE	ΦA	ΦB	C	□D	□DE	E	F	G	H	I	N	P	PT	K	KE	KT	S	T
Φ40	40	25	M22*1.5	70	50	25	30	17	47	9	32	98	3/8"	M12*1.5	10	13	64	13
Φ50	50	30	M26*1.5	85	62	30	30	20	52	9	37	106	1/2"	M14*1.5	10	15	68	13
Φ63	55	35	M30*1.5	100	74	35	35	24	57	9	37	113	1/2"	M16*1.5	10	17	75	13
Φ80	65	45	M39*1.5	125	92	45	35	24	67	9	42	129	3/4"	M18*1.5	10	20	85	15
Φ100	80	50	M40*2.0	160	120	55	40	31	67	9	42	139	3/4"	M22*1.5	10	24	95	18
Φ125	95	70	M64*2.0	190	145	75	45	37	77	9	52	159	1"	M27*1.5	10	31	105	24
Φ140	105	80	M72*2.0	215	160	80	50	40	77	10	52	164	1"	M30*1.5	15	34	110	28
Φ150	120	90	M80*2.0	230	170	90	55	45	80	10	52	174	1"	M33*1.5	15	39	120	30
Φ160	125	90	M80*2.0	240	180	90	55	45	80	10	52	186	1"	M33*1.5	15	39	132	30

### 标准 CGOD型 标准双轴型 Doubles Rod Type

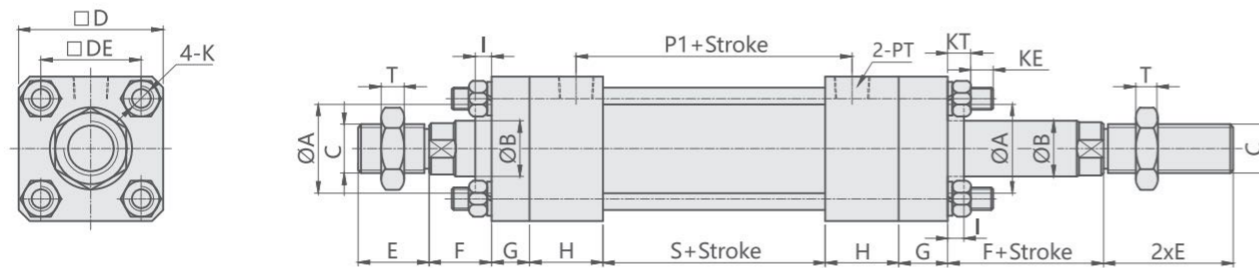

Unit:mm

BORE	ΦA	ΦB	C	□D	□DE	E	F	G	H	I	P1	PT	K	KE	KT	S	T
Φ40	40	25	M22*1.5	70	50	25	30	17	47	9	100	3/8"	M12*1.5	10	13	64	13
Φ50	50	30	M26*1.5	85	62	30	30	20	52	9	108	1/2"	M14*1.5	10	15	68	13
Φ63	55	35	M30*1.5	100	74	35	35	24	57	9	117	1/2"	M16*1.5	10	17	75	13
Φ80	65	45	M39*1.5	125	92	45	35	24	67	9	133	3/4"	M18*1.5	10	20	85	15
Φ100	80	50	M40*2.0	160	120	55	40	31	67	9	143	3/4"	M22*1.5	10	24	95	18
Φ125	95	70	M64*2.0	190	145	75	45	37	77	9	165	1"	M27*1.5	10	31	105	24
Φ140	105	80	M72*2.0	215	160	80	50	40	77	10	170	1"	M30*1.5	15	34	110	28
Φ150	120	90	M80*2.0	230	170	90	55	45	80	10	180	1"	M33*1.5	15	39	120	30
Φ160	125	90	M80*2.0	240	180	90	55	45	80	10	192	1"	M33*1.5	15	39	132	30

#### 注意事项

- 1.轴心加大如未注明长度尺寸时,依照本公司规定自行加工。
- 2.CGO系列行程未超过1500mm时,活塞长度(PM)如附表,订制行程如超过1500mm时,活塞长度(PM)请参阅特性资料表。
- 3.本系列行程如超过2000(含)mm时,须加拉杆中间固定座。
- 4.本系列轴心螺帽规格M50mm(含)以上时,其外径为圆形。
- 5.AST为客户指定之可调行程。

#### NOTE

1. For rods extending processing,if the length is not specified,then it should follow our company's stipulation for processing.
2. For the CGO series whose stroke is less than 1500mm,the length of the piston is shown in the affiliated table,for those customized CGO whose stroke is more than 1500mm,the length of piston conforms to product specification.
3. Middle rod holder must be installed for those CGO whose stroke is equal to or more than 2000mm.
4. The external diameter would be round when the size of rod nut is equal to or more than M50mm.
5. AST stands for adjustable stroke designated by customers.

### 标准CGOD+A型 双轴型附可调帽 Double Rods with Adjustable Nut Type

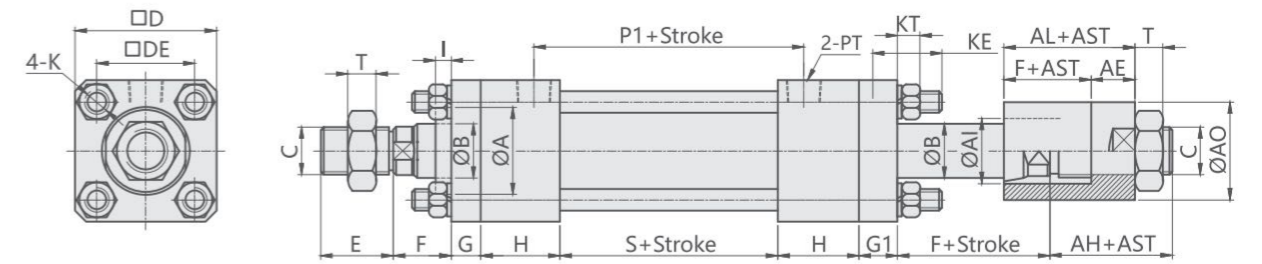

Unit:mm

BORE	ΦA	ΦB	C	□D	□DE	E	F	G	H	I	P1	PT	K	KE	KT	S	T	AI	AL	AO	AE	AH	G1
Φ40	40	25	M22*1.5	70	50	25	30	17	47	9	100	3/8"	M12*1.5	10	13	64	13	30	55	45	25	35	26
Φ50	50	30	M26*1.5	85	62	30	30	20	52	9	108	1/2"	M14*1.5	10	15	68	13	38	60	55	30	40	29
Φ63	55	35	M30*1.5	100	74	35	35	24	57	9	117	1/2"	M16*1.5	10	17	75	13	42	65	65	30	45	33
Φ80	65	45	M39*1.5	125	92	45	35	24	67	9	133	3/4"	M18*1.5	10	20	85	15	52	70	75	35	55	33
Φ100	80	50	M40*2.0	160	120	55	40	31	67	9	143	3/4"	M22*1.5	10	24	95	18	63	75	90	35	65	40
Φ125	95	70	M64*2.0	190	145	75	45	37	77	9	165	1"	M27*1.5	10	31	105	24	78	85	105	40	80	46
Φ140	105	80	M72*2.0	215	160	80	50	40	77	10	170	1"	M30*1.5	15	34	110	28	90	90	120	40	85	50
Φ150	120	90	M80*2.0	230	170	90	55	45	80	10	180	1"	M33*1.5	15	39	120	30	100	100	130	45	95	55
Φ160	125	90	M80*2.0	240	180	90	55	45	80	10	192	1"	M33*1.5	15	39	132	30	100	100	130	45	95	55

### 标准CGOB+FA型 前法兰型 Front Flange Mounting Type

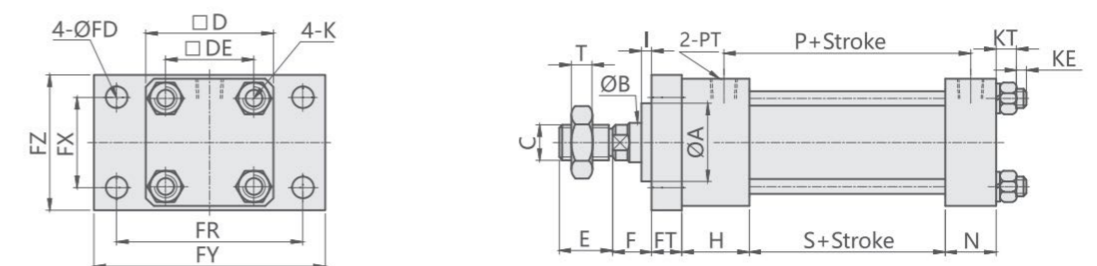

Unit:mm

BORE	ΦA	ΦB	C	□D	□DE	E	F	G	H	I	N	P	PT	K	KE	KT	S	T	ΦFD	FT	FR	FX	FY	FZ
Φ40	40	25	M22*1.5	70	50	25	30	17	47	9	32	98	3/8"	M12*1.5	10	13	64	13	11	17	98	50	122	73
Φ50	50	30	M26*1.5	85	62	30	30	20	52	9	37	106	1/2"	M14*1.5	10	15	68	13	14	20	118	60	145	88
Φ63	55	35	M30*1.5	100	74	35	35	24	57	9	37	113	1/2"	M16*1.5	10	17	75	13	18	24	140	73	175	106
Φ80	65	45	M39*1.5	125	92	45	35	24	67	9	42	129	3/4"	M18*1.5	10	20	85	15	22	24	175	90	210	130
Φ100	80	50	M40*2.0	160	120	55	40	31	67	9	42	139	3/4"	M22*1.5	10	24	95	18	26	31	215	115	260	165
Φ125	95	70	M64*2.0	190	145	75	45	37	77	9	52	159	1"	M27*1.5	10	31	105	24	33	37	270	145	330	205
Φ140	105	80	M72*2.0	215	160	80	50	40	77	10	52	164	1"	M30*1.5	15	34	110	28	33	40	280	160	335	218
Φ150	120	90	M80*2.0	230	170	90	55	45	80	10	52	174	1"	M33*1.5	15	39	120	30	36	45	315	180	375	243
Φ160	125	90	M80*2.0	240	180	90	55	45	80	10	52	186	1"	M33*1.5	15	39	132	30	36	45	315	180	375	243

标准CGOB+FB型 后法兰型 Rear Flange Mounting Type

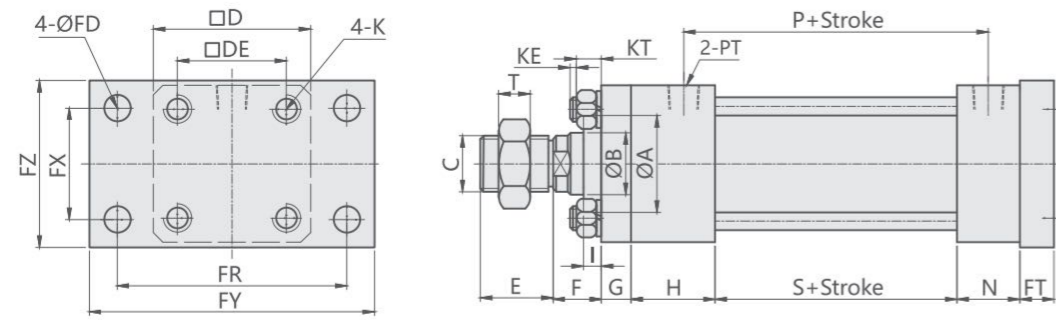

Unit:mm

BORE	ΦA	ΦB	C	□D	□DE	E	F	G	H	I	N	P	PT	K	KE	KT	S	T	ΦFD	FT	FR	FX	FY	FZ
Φ40	40	25	M22*1.5	70	50	25	30	17	47	9	32	98	3/8"	M12*1.5	10	13	64	13	11	17	98	50	122	73
Φ50	50	30	M26*1.5	85	62	30	30	20	52	9	37	106	1/2"	M14*1.5	10	15	68	13	14	20	118	60	145	88
Φ63	55	35	M30*1.5	100	74	35	35	24	57	9	37	113	1/2"	M16*1.5	10	17	75	13	18	24	140	73	175	106
Φ80	65	45	M39*1.5	125	92	45	35	24	67	9	42	129	3/4"	M18*1.5	10	20	85	15	22	24	175	90	210	130
Φ100	80	50	M40*2.0	160	120	55	40	31	67	9	42	139	3/4"	M22*1.5	10	24	95	18	26	31	215	115	260	165
Φ125	95	70	M64*2.0	190	145	75	45	37	77	9	52	159	1"	M27*1.5	10	31	105	24	33	37	270	145	330	205
Φ140	105	80	M72*2.0	215	160	80	50	40	77	10	52	164	1"	M30*1.5	15	34	110	28	33	40	280	160	335	218
Φ150	120	90	M80*2.0	230	170	90	55	45	80	10	52	174	1"	M33*1.5	15	39	120	30	36	45	315	180	375	243
Φ160	125	90	M80*2.0	240	180	90	55	45	80	10	52	186	1"	M33*1.5	15	39	132	30	36	45	315	180	375	243

标准CGOB+TA型 前耳轴型 Front Trunnion Mounting Type

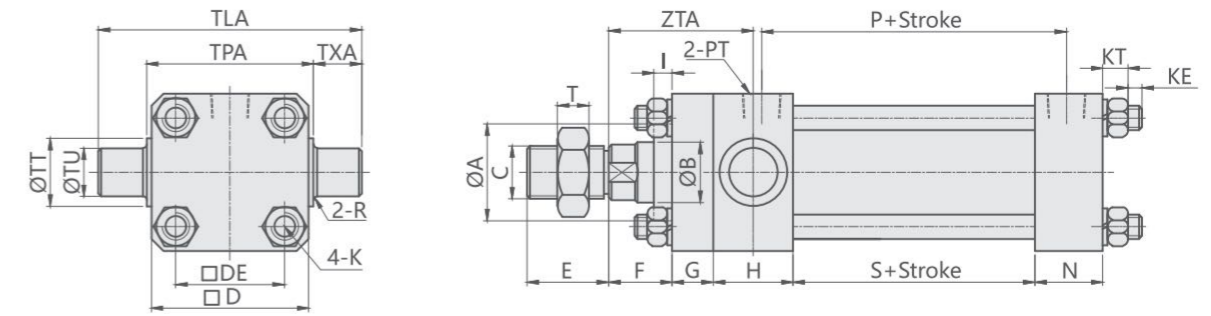

Unit:mm

BORE	ΦA	ΦB	C	□D	□DE	E	F	G	H	I	N	P	PT	K	KE	KT	S	T	ΦTT	ZTA	ΦTU	TLA	TPA	TXA	R
Φ40	40	25	M22*1.5	70	50	25	30	17	47	9	32	98	3/8"	M12*1.5	10	13	64	13	33	70.5	25	123	73	25	2.5
Φ50	50	30	M26*1.5	85	62	30	30	20	52	9	37	106	1/2"	M14*1.5	10	15	68	13	33	76	25	138	88	25	2.5
Φ63	55	35	M30*1.5	100	74	35	35	24	57	9	37	113	1/2"	M16*1.5	10	17	75	13	43	87.5	31.5	169	106	31.5	2.5
Φ80	65	45	M39*1.5	125	92	45	35	24	67	9	42	129	3/4"	M18*1.5	10	20	85	15	53	92.5	40	208	128	40	3
Φ100	80	50	M40*2.0	160	120	55	40	31	67	9	42	139	3/4"	M22*1.5	10	24	95	18	63	104.5	50	270	170	50	3
Φ125	95	70	M64*2.0	190	145	75	45	37	77	9	52	159	1"	M27*1.5	10	31	105	24	78	120.5	63	331	205	63	4
Φ140	105	80	M72*2.0	215	160	80	50	40	77	10	52	164	1"	M30*1.5	15	34	110	28	88	128.5	71	367	225	71	4
Φ150	120	90	M80*2.0	230	170	90	55	45	80	10	52	174	1"	M33*1.5	15	39	120	30	98	140	80	415	245	80	4
Φ160	125	90	M80*2.0	240	180	90	55	45	80	10	52	186	1"	M33*1.5	15	39	132	30	98	140	80	415	255	80	4

标准CGOB+TC型 中间耳轴型 Middle Trunnion Mounting Type

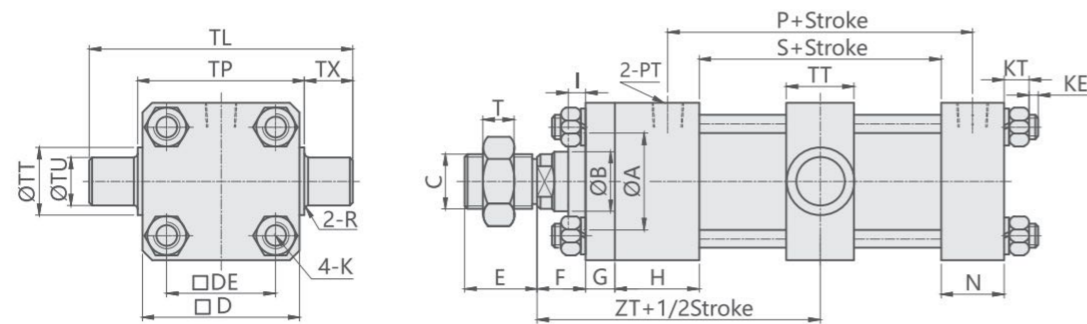

Unit:mm

BORE	ΦA	ΦB	C	□D	□DE	E	F	G	H	I	N	P	PT	K	KE	KT	S	T	TT	ZT	ΦTU	TL	TP	TX	R
Φ40	40	25	M22*1.5	70	50	25	30	17	47	9	32	98	3/8"	M12*1.5	10	13	64	13	33	125	25	123	73	25	2.5
Φ50	50	30	M26*1.5	85	62	30	30	20	52	9	37	106	1/2"	M14*1.5	10	15	68	13	33	136	25	138	88	25	2.5
Φ63	55	35	M30*1.5	100	74	35	35	24	57	9	37	113	1/2"	M16*1.5	10	17	75	13	43	154	31.5	169	106	31.5	2.5
Φ80	65	45	M39*1.5	125	92	45	35	24	67	9	42	129	3/4"	M18*1.5	10	20	85	15	53	169	40	208	128	40	3
Φ100	80	50	M40*2.0	160	120	55	40	31	67	9	42	139	3/4"	M22*1.5	10	24	95	18	63	185	50	270	170	50	3
Φ125	95	70	M64*2.0	190	145	75	45	37	77	9	52	159	1"	M27*1.5	10	31	105	24	78	212	63	331	205	63	4
Φ140	105	80	M72*2.0	215	160	80	50	40	77	10	52	164	1"	M30*1.5	15	34	110	28	88	222	71	367	225	71	4
Φ150	120	90	M80*2.0	230	170	90	55	45	80	10	52	174	1"	M33*1.5	15	39	120	30	98	240	80	415	245	80	4
Φ160	125	90	M80*2.0	240	180	90	55	45	80	10	52	186	1"	M33*1.5	15	39	132	30	98	246	80	415	255	80	4

标准CGOB+LA型 左右脚座型 Right & Left Foot Mounting Type

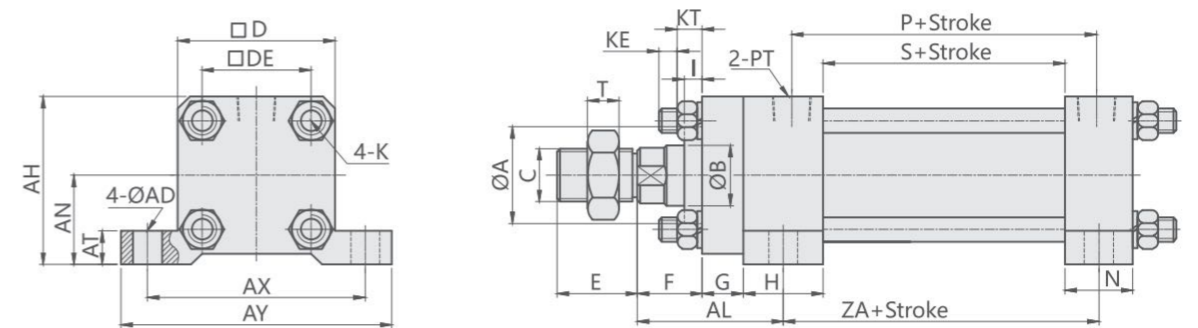

Unit:mm

BORE	ΦA	ΦB	C	□D	□DE	E	F	G	H	I	N	P	PT	K	KE	KT	S	T	ZA	AL	AT	AN	AH	ΦAD	AY	AX
Φ40	40	25	M22*1.5	70	50	25	30	17	47	9	32	98	3/8"	M12*1.5	10	13	64	13	111	63	15	42	77	11	122	98
Φ50	50	30	M26*1.5	85	62	30	30	20	52	9	37	106	1/2"	M14*1.5	10	15	68	13	120	68	20	55	97.5	14	145	118
Φ63	55	35	M30*1.5	100	74	35	35	24	57	9	37	113	1/2"	M16*1.5	10	17	75	13	132	77	25	63	113	18	175	140
Φ80	65	45	M39*1.5	125	92	45	35	24	67	9	42	129	3/4"	M18*1.5	10	20	85	15	152	80	30	75	137.5	22	210	175
Φ100	80	50	M40*2.0	160	120	55	40	31	67	9	42	139	3/4"	M22*1.5	10	24	95	18	162	94	35	85	165	26	260	215
Φ125	95	70	M64*2.0	190	145	75	45	37	77	9	52	159	1"	M27*1.5	10	31	105	24	182	110	45	105	200	33	330	270
Φ140	105	80	M72*2.0	215	160	80	50	40	77	10	52	164	1"	M30*1.5	15	34	110	28	187	118	45	112	219.5	33	335	280
Φ150	120	90	M80*2.0	230	170	90	55	45	80	10	52	174	1"	M33*1.5	15	39	120	30	200	131	50	120	235	36	365	300
Φ160	125	90	M80*2.0	240	180	90	55	45	80	10	52	186	1"	M33*1.5	15	39	132	30	212	131	50	125	245	36	375	315

标准 CGOB+LB型 前后脚座型 Front & Rear Foot Mounting Type

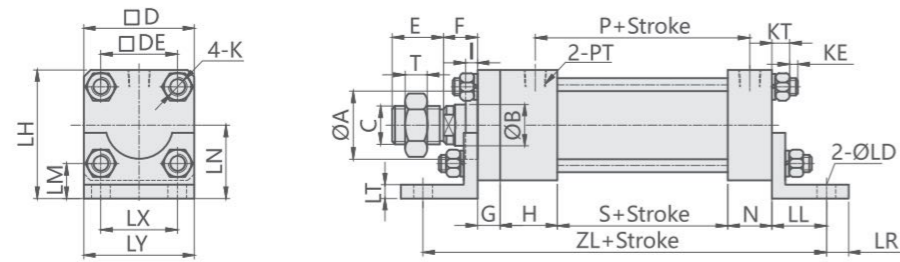

Unit:mm

BORE	ΦA	ΦB	C	□D	□DE	E	F	G	H	I	N	P	PT	K	KE	KT	S	T	ΦLD	LR	LL	ZL	LT	LH	LM	LX	LY	LN
Φ40	40	25	M22*1.5	70	50	25	30	17	47	9	32	98	3/8"	M12*1.5	10	13	64	13	14	20	42	244	8	83	23	50	70	48
Φ50	50	30	M26*1.5	85	62	30	30	20	52	9	37	106	1/2"	M14*1.5	10	15	68	13	16	22	46	269	10	100	26.5	62	85	57.5
Φ63	55	35	M30*1.5	100	74	35	35	24	57	9	37	113	1/2"	M16*1.5	10	17	75	13	18	27	65	323	13	118	31	74	100	68
Φ80	65	45	M39*1.5	125	92	45	35	24	67	9	42	129	3/4"	M18*1.5	10	20	85	15	20	30	70	358	15	145	36.5	92	125	82.5
Φ100	80	50	M40*2.0	160	120	55	40	31	67	9	42	139	3/4"	M22*1.5	10	24	95	18	24	32	80	395	18	188	48	120	160	108
Φ125	95	70	M64*2.0	190	145	75	45	37	77	9	52	159	1"	M27*1.5	10	31	105	24	28	35	90	451	20	220	52.5	145	190	125
Φ140	105	80	M72*2.0	215	160	80	50	40	77	10	52	164	1"	M30*1.5	15	34	110	28	32	40	95	469	25	250	62.5	160	215	142.5
Φ150	120	90	M80*2.0	230	170	90	55	45	80	10	52	174	1"	M33*1.5	15	39	120	30	35	40	100	497	28	268	68	170	230	153
Φ160	125	90	M80*2.0	240	180	90	55	45	80	10	52	186	1"	M33*1.5	15	39	132	30	35	40	100	509	28	278	68	180	240	158

标准 CGOB+CA 单耳型 Single Trunnion Mounting Type

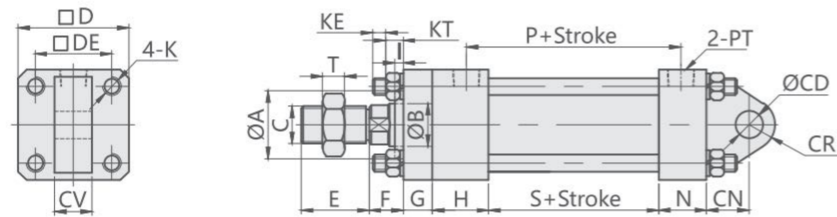

Unit:mm

BORE	ΦA	ΦB	C	□D	□DE	E	F	G	H	I	N	P	PT	K	KE	KT	S	T	CN	ΦCD	CR	CV
Φ40	40	25	M22*1.5	70	50	25	30	17	47	9	32	98	3/8"	M12*1.5	10	13	64	13	25	20	25	32
Φ50	50	30	M26*1.5	85	62	30	30	20	52	9	37	106	1/2"	M14*1.5	10	15	68	13	32	25	30	36
Φ63	55	35	M30*1.5	100	74	35	35	24	57	9	37	113	1/2"	M16*1.5	10	17	75	13	40	31.5	35	40
Φ80	65	45	M39*1.5	125	92	45	35	24	67	9	42	129	3/4"	M18*1.5	10	20	85	15	50	40	45	50
Φ100	80	50	M40*2.0	160	120	55	40	31	67	9	42	139	3/4"	M22*1.5	10	24	95	18	63	50	55	63
Φ125	95	70	M64*2.0	190	145	75	45	37	77	9	52	159	1"	M27*1.5	10	31	105	24	79	63	70	80
Φ140	105	80	M72*2.0	215	160	80	50	40	77	10	52	164	1"	M30*1.5	15	34	110	28	89	71	80	80
Φ150	120	90	M80*2.0	230	170	90	55	45	80	10	52	174	1"	M33*1.5	15	39	120	30	100	80	90	100
Φ160	125	90	M80*2.0	240	180	90	55	45	80	10	52	186	1"	M33*1.5	15	39	132	30	100	80	90	100

标准 CGOB+CB型 双耳型 Double Trunnion Type

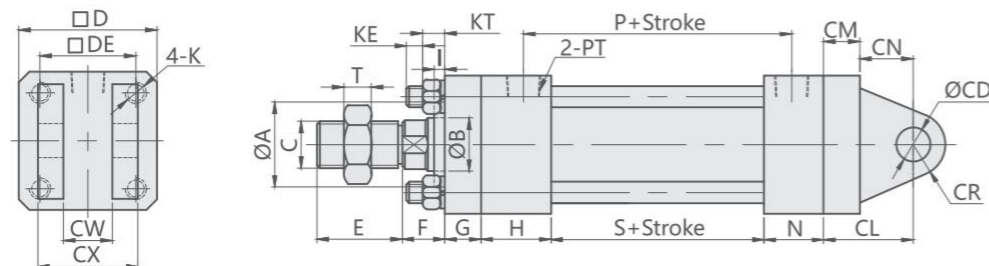

Unit:mm

BORE	ΦA	ΦB	C	□D	□DE	E	F	G	H	I	N	P	PT	K	KE	KT	S	CM	CN	T	ΦCD	CR	CL	CW	CX
Φ40	40	25	M22*1.5	70	50	25	30	17	47	9	32	98	3/8"	M12*1.5	10	13	64	17	25	13	20	25	42	32.5	64
Φ50	50	30	M26*1.5	85	62	30	30	20	52	9	37	106	1/2"	M14*1.5	10	15	68	20	32	13	25	30	52	36.5	72
Φ63	55	35	M30*1.5	100	74	35	35	24	57	9	37	113	1/2"	M16*1.5	10	17	75	24	40	13	31.5	35	64	40.5	80
Φ80	65	45	M39*1.5	125	92	45	35	24	67	9	42	129	3/4"	M18*1.5	10	20	85	24	50	15	40	45	74	50.5	100
Φ100	80	50	M40*2.0	160	120	55	40	31	67	9	42	139	3/4"	M22*1.5	10	24	95	31	63	18	50	55	94	63.5	126
Φ125	95	70	M64*2.0	190	145	75	45	37	77	9	52	159	1"	M27*1.5	10	31	105	37	79	24	63	70	116	80.5	150
Φ140	105	80	M72*2.0	215	160	80	50	40	77	10	52	164	1"	M30*1.5	15	34	110	40	89	28	71	80	129	80.5	160
Φ150	120	90	M80*2.0	230	170	90	55	45	80	10	52	174	1"	M33*1.5	15	39	120	45	100	30	80	90	145	100.5	200
Φ160	125	90	M80*2.0	240	180	90	55	45	80	10	52	186	1"	M33*1.5	15	39	132	45	100	30	80	90	145	100.5	200

CGO 系列型接头、Y型接头 CGO Series I,Y type connector

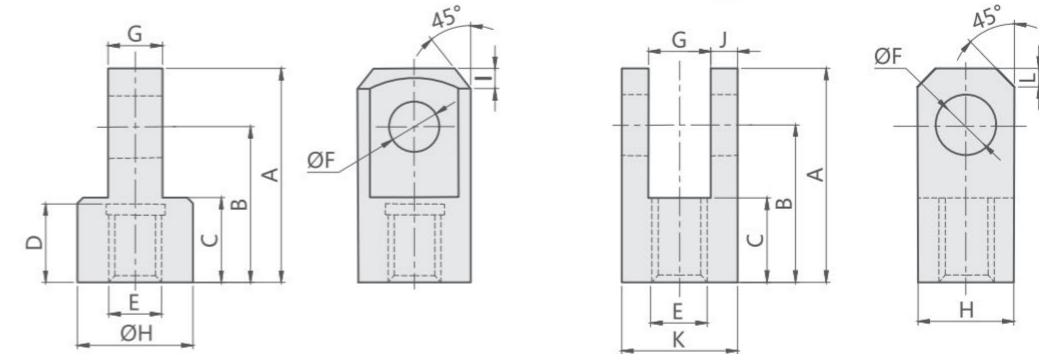

Unit:mm

BORE	A	B	C	D	E	F	G	H	I	J	K	L
Φ40	70	50	25	25	M22*1.5	20	32	40	8	16	64	10
Φ50	85	60	30	30	M26*1.5	25	36	50	10	18	72	12
Φ63	105	70	35	35	M30*1.5	31.5	40	63	15	20	80	15
Φ80	130	90	45	45	M39*1.5	40	50	80	20	25	100	20
Φ100	160	110	55	55	M40*2.0	50	63	100	25	31.5	126	25
Φ125	205	142	75	75	M64*2.0	63	75	126	30	40	150	30
Φ140	230	155	80	80	M72*2.0	71	80	142	35	40	160	35
Φ150	255	175	90	90	M80*2.0	80	100	160	40	50	200	40
Φ160	255	175	90	90	M80*2.0	80	100	160	40	50	200	40

GB板接头销 GB Plate.Y Joint Pin

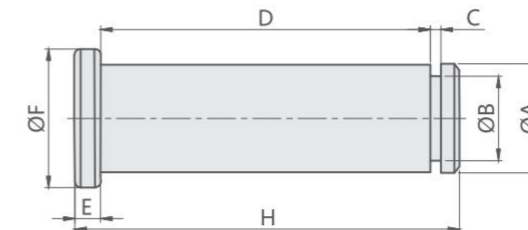

Unit:mm

BORE	ΦA	ΦB	C	D	E	ΦF	H
Φ40	Φ20 <sup>-0.02</sup> <sub>-0.072</sub>	Φ19 <sup>0</sup> <sub>-0.11</sub>	1.1	65	5	Φ25	77
Φ50	Φ25 <sup>-0.02</sup> <sub>-0.072</sub>	Φ23.9 <sup>0</sup> <sub>-0.21</sub>	1.3	73	5	Φ30	85
Φ63	Φ31.5 <sup>-0.02</sup> <sub>-0.072</sub>	Φ28.6 <sup>0</sup> <sub>-0.21</sub>	1.3	81	5	Φ36	93
Φ80	Φ40 <sup>-0.025</sup> <sub>-0.087</sub>	Φ37.5 <sup>0</sup> <sub>-0.25</sub>	1.7	101	8	Φ50	118
Φ100	Φ50 <sup>-0.025</sup> <sub>-0.087</sub>	Φ47 <sup>0</sup> <sub>-0.25</sub>	2.2	127	8	Φ60	144
Φ125	Φ63 <sup>-0.03</sup> <sub>-0.104</sub>	Φ60 <sup>0</sup> <sub>-0.3</sub>	2.7	151	10	Φ70	173
Φ140	Φ71 <sup>-0.03</sup> <sub>-0.104</sub>	Φ67 <sup>0</sup> <sub>-0.3</sub>	2.7	161	10	Φ80	183
Φ150	Φ80 <sup>-0.03</sup> <sub>-0.104</sub>	Φ76.5 <sup>0</sup> <sub>-0.3</sub>	2.7	201	10	Φ90	223
Φ160	Φ80 <sup>-0.03</sup> <sub>-0.104</sub>	Φ76.5 <sup>0</sup> <sub>-0.3</sub>	2.7	201	10	Φ90	223

# CHRO

系列大型油压缸

## CHRO SERIES 21MPA ROUND HYDRAULIC CYLINDER



### 大型油压缸结构图 INSIDE STRUCTURE

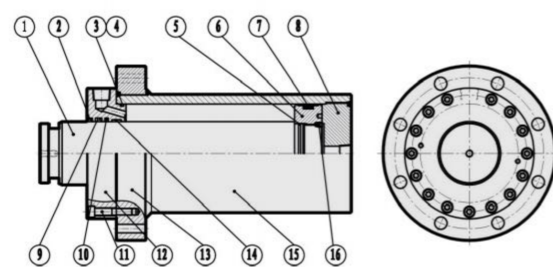

CHROA

NO	零件名 Part name	数量 Quantity	NO	零件名 Part name	数量 Quantity	NO	零件名 Part name	数量 Quantity
1	活塞杆Piston rod	1	7	活塞专用密封圈 Piston Seal	2	13	法兰板 Front flange	1
2	防尘油封 Dustproof seal	1	8	后端盖 End cover	1	14	导向带 Guidance tape	1
3	O型圈 Gasket	1	9	轴用油封 Oil seal for shaft	1	15	缸筒 Cylinder tube	1
4	O型圈支撑环 Gasket support ring	1	10	活塞杆阶梯封 Rod ladder seal	1	16	止动螺钉 Lock screw	1
5	O型圈 Gasket	1	11	内六角螺钉 Socket Head cup screw	15			
6	活塞 Piston	1	12	前端盖 Rod Cover	1			

### 大型油压缸特性资料 Specifications

油缸内径 Hydraulic cylinder inside diameter(mm)	Φ125	Φ150	Φ180	Φ200	Φ225	Φ250	Φ280	Φ300
工作流体 Power Fluid	以滤清之标准液压油 Filtered Oil							
缸管材质 Material of cylinder barrel	碳钢管 Carbon steel STKM-13c/白铁管 Stainless tubes SUS 304							
使用压力范围 The range of pressure(MPa)	1-21MPa (10-210kg/cm <sup>2</sup> )							
使用速度范围 The range of speed (mm/sec)	8~500(mm/sec)							
使用温度范围 Range of temperature(°C)	-30 ~ +100 (°C)							
标准活塞长度 Length of standard piston (PM)	60	60	70	70	70	70	70	70
订制行程于 1501-2500mm 间活塞长度 (PM) Piston length when the stroke is between 1501-2500 mm	120	120	140	140	140	140	140	150
订制行程于 2501-4000mm 间活塞长度 (PM) Customized stroke is 2501-4000mm	200	200	200	200	200	200	200	200

### 订购标示法 ORDERING INDICATION

示例: CHROA-125/60-100-Y-DM

CHROA	系列 Series	CHROA PT在法兰前 PT in front of flange		CHROB PT在法兰后 PT in rear of flange	
		CHROC CA型 CA type		CHROD 双轴型 Double Rods type	
		CHROE 法兰在后侧 Rear flange type			
125	油缸内径 Hydraulic cylinder inside diameter		Φ125 Φ150 Φ180 Φ200 Φ225 Φ250 Φ280 Φ300		
60	轴心 Rod	标准 Standard 最大 Max	Φ60 Φ80 Φ100 Φ125 Φ140 Φ160 Φ180 Φ200 Φ80 Φ100 Φ120 Φ140 Φ160 Φ200 Φ220 Φ250		
100	行程 Stroke	钢管 Steel barrel (Φ125-Φ300)		最大行程: 4米 Max:4m	
Y	轴心固定型式 Accessories	YP Y附Pin		TW 半月套 TW rod end mounting	
		Y connectors with pin		TH 半月套+焊套 TH rod end mounting	
		I 型接头 I connectors		A 可调螺帽 Adjustable nut	
DM	无记号:心车沟 Blank: Standard DM: 车牙型 DM type				

标准 CHROA 型 标准A型 Single Rod Type

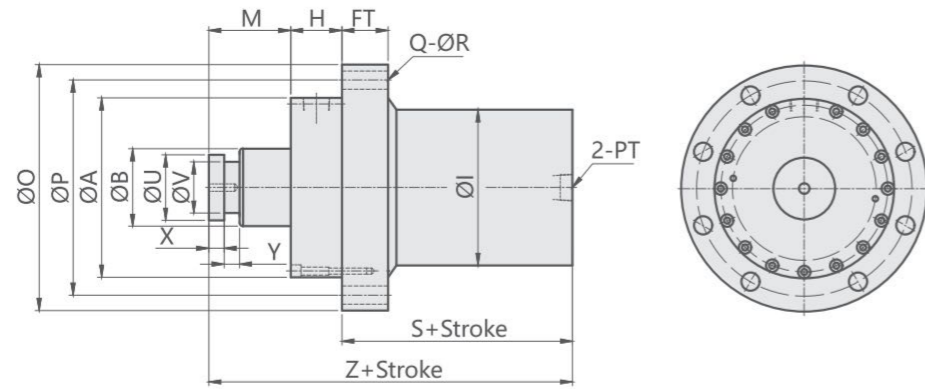

标准 CHROD 型 双轴型附可调帽 Double Rods with Adjustable Nut Type

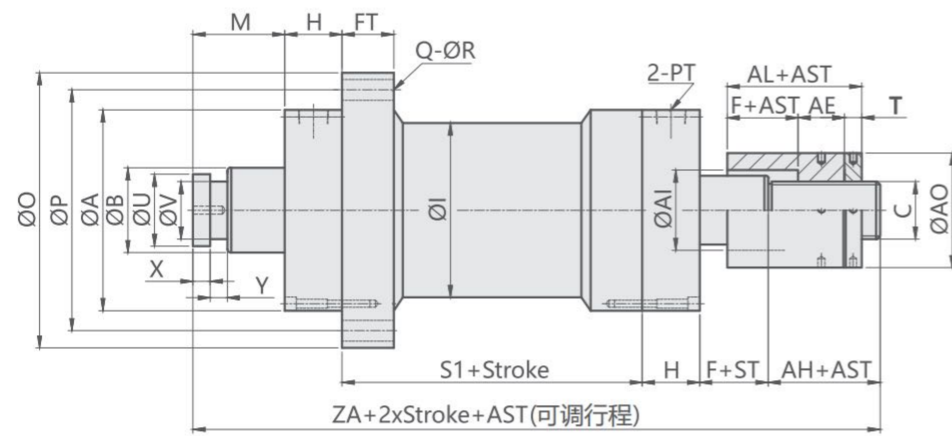

Unit:mm

BORE	CHROA-CHROD TYPE																	A(可调帽)TYPE										
	A	B	C	F	FT	H	I	M	O	P	PM	PT	Q	R	S	S1	T	U	V	X	Y	Z	ZA	AH	AE	AI	AO	AL
Φ125	175	60	M50XP2.0	25	45	50	152	80	240	210	60	3/4"	6	18	125	100	15	60	50	15	15	255	355	50	35	70	100	60
Φ150	200	80	M70XP2.0	25	50	50	180	80	280	240	60	1"	6	18	130	100	20	80	70	15	15	260	365	60	40	95	120	65
Φ180	240	100	M90XP2.0	30	60	60	216	100	320	280	70	1"	6	18	150	110	30	95	85	25	25	310	430	70	40	120	150	70
Φ200	260	125	M100XP2.0	30	65	70	242	100	350	310	70	1.1/4"	6	20	155	110	30	115	100	25	25	325	450	70	40	140	180	70
Φ225	290	140	M120XP3.0	30	70	70	270	120	380	340	70	1.1/4"	8	20	160	110	30	135	120	25	25	350	475	75	45	160	200	75
Φ250	330	160	M140XP3.0	30	75	75	298	120	440	380	70	1.1/4"	8	24	170	120	35	155	140	30	30	365	505	85	50	190	240	80
Φ280	360	180	M160XP3.0	30	80	80	330	150	500	430	70	1.1/2"	10	26	175	120	40	175	150	30	30	405	550	90	50	210	260	80
Φ300	380	200	M180XP3.0	35	85	90	350	150	550	460	90	1.1/2"	10	28	200	140	40	195	170	35	35	440	605	100	60	230	290	95

注意事项

- 1.CHRO行程超过1500mm时, 活塞长度(PM)自行加长, 其加长尺寸请参阅特性资料表。
- 2.本系列轴心加大时, 其相关尺寸依加大比例自行放大。
- 3.AST为客户指定之可调行程。

NOTE

- 1.Piston length proportionally extends if the stroke of CHRO is more than 1500mm,the extending length conforms to characteristics table.
- 2.In this hydraulic cylinder series,relevant size of the other part proportionally extends when the rod is extending.
- 3.AST stands for adjustable stroke designated by customers.

标准CHROB型标准B型 Single Rod Type

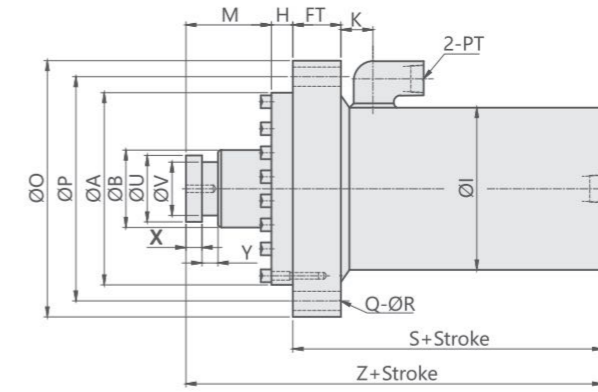

Unit:mm

CHROB TYPE																			
BORE	A	B	FT	H	I	K	M	O	P	PM	PT	Q	R	S	U	V	X	Y	Z
Φ125	180	60	45	20	152	30	80	240	210	60	3/4"	6	18	190	60	50	15	15	290
Φ150	205	80	50	20	180	30	80	280	240	60	1"	6	18	200	80	70	15	15	300
Φ180	245	100	60	30	216	30	100	320	280	70	1"	6	18	230	95	85	20	20	360
Φ200	265	125	65	30	242	35	100	350	310	70	1.1/4"	6	20	250	115	100	25	25	380
Φ225	295	140	70	35	270	35	120	380	340	70	1.1/4"	8	20	260	135	120	25	25	415
Φ250	335	160	75	35	298	40	120	440	380	70	1.1/4"	8	24	275	155	140	30	30	430
Φ280	365	180	80	40	330	40	150	500	430	70	1.1/2"	10	26	290	175	150	30	30	480
Φ300	385	200	85	40	350	45	150	550	460	90	1.1/2"	10	28	320	195	170	35	35	510

注意事项

- 1.CHRO行程超过1500mm时, 活塞长度(PM)自行加长, 其加长尺寸请参阅特性资料表。
- 2.本系列轴心加大时, 其相关尺寸依加大比例自行放大。

NOTE

- 1.Piston length proportionally extends if the stroke of CHRO is more than 1500mm,the extending length conforms to characteristics table.
- 2.In this hydraulic cylinder series,relevant size of the other part proportionally extends when the rod is extending.

外牙型规格表 Vertical screw of rod

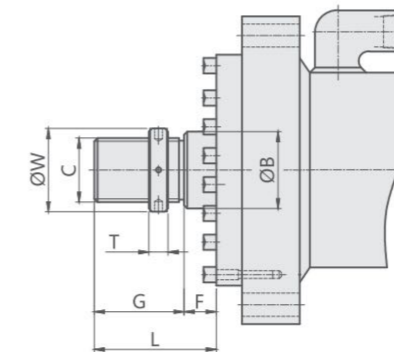

Unit:mm

CHROB TYPE							
BORE	B	C	F	G	L	T	W
Φ125	60	M50XP2.0	25	70	95	15	65
Φ150	80	M70XP2.0	25	80	105	20	95
Φ180	100	M90XP2.0	30	100	130	30	120
Φ200	125	M100XP2.0	30	120	150	30	140
Φ225	140	M120XP3.0	30	140	170	30	160
Φ250	160	M140XP3.0	30	150	180	35	190
Φ280	180	M160XP4.0	30	160	190	40	210
Φ300	200	M180XP4.0	35	160	195	40	230

### 标准 CHROC型 单耳轴型 Single Trunnion Mounting Type

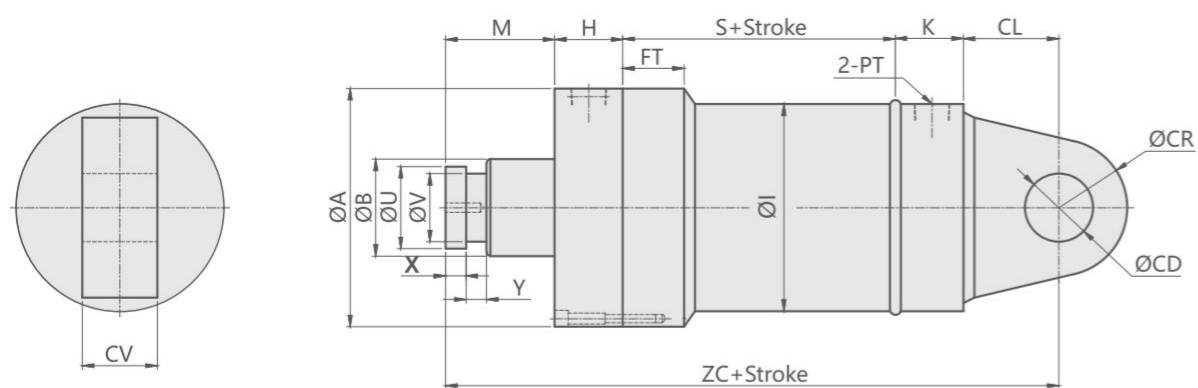

Unit:mm

HROC TYPE														CA TYPE					
BORE	A	B	H	I	FT	K	M	PM	PT	S	U	V	X	Y	ZC	CD	CL	CR	CV
Φ125	175	60	50	152	45	50	80	60	3/4"	100	60	50	15	15	270	50	70	50	55
Φ150	200	80	50	180	50	55	80	60	1"	100	80	70	15	15	285	60	80	60	60
Φ180	240	100	60	216	60	55	100	70	1"	110	95	85	20	20	325	70	100	70	80
Φ200	260	125	70	242	65	65	100	70	1.1/4"	110	115	100	25	25	355	80	110	80	90
Φ225	290	140	70	270	70	65	120	70	1.1/4"	110	135	120	25	25	365	90	120	90	100
Φ250	330	160	75	298	75	70	120	70	1.1/4"	115	155	140	30	30	410	100	150	100	120
Φ280	360	180	80	330	80	80	150	70	1.1/2"	115	175	150	30	30	425	100	150	100	120
Φ300	380	200	90	350	85	80	150	90	1.1/2"	135	195	170	35	35	465	120	160	120	140

#### 注意事项

- 1.CHRO行程超过1500mm时, 活塞长度(PM)自行加长, 其加长尺寸请参阅特性资料表。
- 2.本系列轴心加大时, 其相关尺寸依加大比例自行放大。

#### NOTE

- 1.Piston length proportionally extends if the stroke of CHRO is more than 1500mm,the extending length conforms to characteristics table.
- 2.In this hydraulic cylinder series,relevant size of other part proportionally extends when the rod is extending.

### 外牙型规格表 Vertical screw of rod

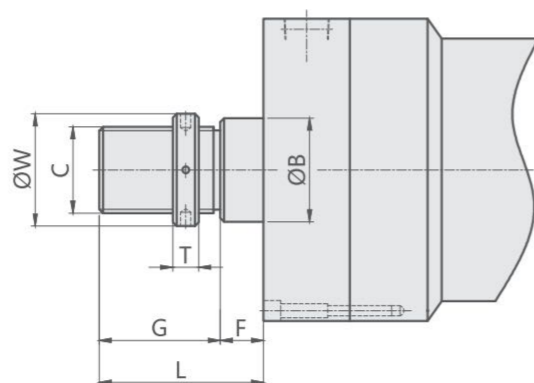

Unit:mm

BORE	B	C	F	G	L	T	W
Φ125	60	M50XP2.0	25	70	95	15	65
Φ150	80	M70XP2.0	25	80	105	20	95
Φ180	100	M90XP2.0	30	100	130	30	120
Φ200	125	M100XP2.0	30	120	150	30	140
Φ225	140	M120XP3.0	30	140	170	30	160
Φ250	160	M140XP3.0	30	150	180	35	190
Φ280	180	M160XP4.0	30	160	190	40	210
Φ300	200	M180XP4.0	35	160	195	40	230

### 标准 CHROE型 后法型 Rear Flange Mounting Type

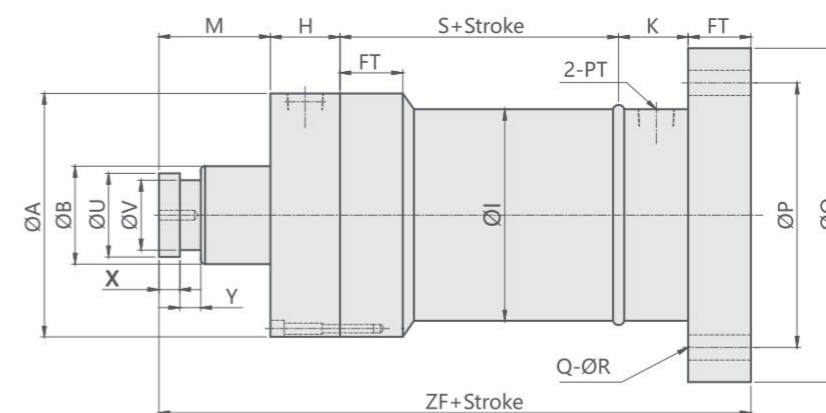

Unit:mm

CHROE TYPE																			
BORE	A	B	FT	H	I	K	M	O	P	PM	PT	Q	R	S	U	V	X	Y	ZF
Φ125	175	60	45	50	152	50	80	240	190	60	3/4"	6	18	100	60	50	15	15	245
Φ150	200	80	50	50	180	55	80	280	240	60	1"	6	18	100	80	70	15	15	255
Φ180	240	100	60	60	216	55	100	320	280	70	1"	6	18	110	95	85	20	20	285
Φ200	260	125	65	70	242	65	100	350	310	70	1.1/4"	6	20	110	115	100	25	25	310
Φ225	290	140	70	70	270	65	120	380	340	70	1.1/4"	8	20	110	135	120	25	25	315
Φ250	330	160	75	75	298	70	120	440	380	70	1.1/4"	8	24	115	155	140	30	30	335
Φ280	360	180	80	80	330	80	150	500	430	70	1.1/2"	10	26	115	175	150	30	30	355
Φ300	380	200	85	90	350	80	150	550	460	90	1.1/2"	10	28	135	195	170	35	35	390

#### 注意事项

- 1.CHRO行程超过1500mm时, 活塞长度(PM)自行加长, 其加长尺寸请参阅特性资料表。
- 2.本系列轴心加大时, 其相关尺寸依加大比例自行放大。

#### NOTE

- 1.Piston length proportionally extends if the stroke of CHRO is more than 1500mm,the extending length conforms to characteristics table.
- 2.In this hydraulic cylinder series,relevant size of other part proportionally extends when the rod is extending.

### 外牙型规格表 Vertical screw of rod

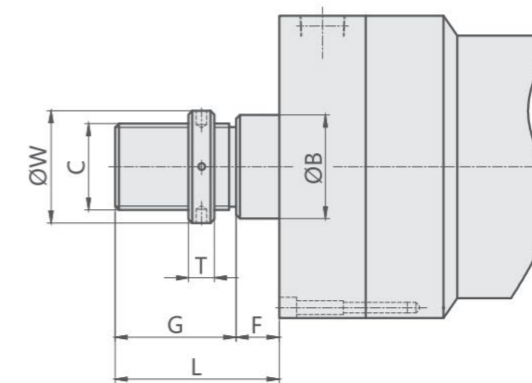

Unit:mm

BORE	B	C	F	G	L	T	W
Φ125	60	M50XP2.0	25	70	95	15	65
Φ150	80	M70XP2.0	25	80	105	20	95
Φ180	100	M90XP2.0	30	100	130	30	120
Φ200	125	M100XP2.0	30	120	150	30	140
Φ225	140	M120XP3.0	30	140	170	30	160
Φ250	160	M140XP3.0	30	150	180	35	190
Φ280	180	M160XP4.0	30	160	190	40	210
Φ300	200	M180XP4.0	35	160	195	40	230

大型油压缸轴心配件尺寸 Accessories For CHRO Series Cylinders

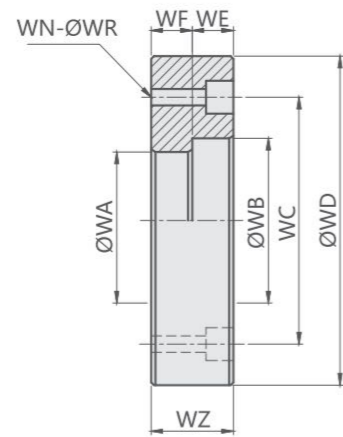

Unit:mm

TW 半月套 TW Rod end Mounting									
TYPE	WA	WB	WC	WD	WE	WF	WN	WR	WZ
TW-125	50	60	90	120	15	15	6	12	30
TW-150	70	80	110	140	15	15	6	12	30
TW-180	85	95	140	180	20	20	6	14	40
TW-200	100	115	160	200	25	25	6	14	50
TW-225	120	135	180	220	25	25	8	18	50
TW-250	140	155	210	260	30	30	8	18	60
TW-280	150	175	140	300	30	30	8	22	60
TW-300	170	195	260	320	35	35	8	22	70

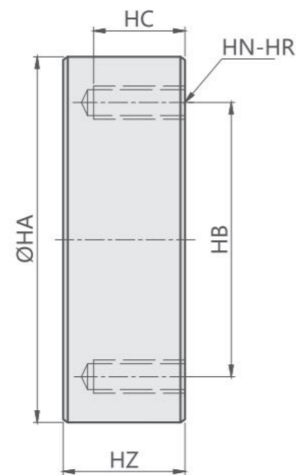

Unit:mm

TH 焊接图板 TH Rod end Mounting						
TYPE	HA	HB	HC	HN	HR	HZ
TW-125	120	90	30	6	M10xP1.5	40
TW-150	140	110	30	6	M10xP1.5	40
TW-180	180	140	35	6	M12xP1.75	45
TW-200	200	160	35	6	M12xP1.75	45
TW-225	220	180	40	8	M16xP2.0	50
TW-250	260	210	40	8	M16xP2.0	50
TW-280	300	240	45	8	M20xP2.5	55
TW-300	320	260	50	8	M20xP2.5	60

Material:SS41

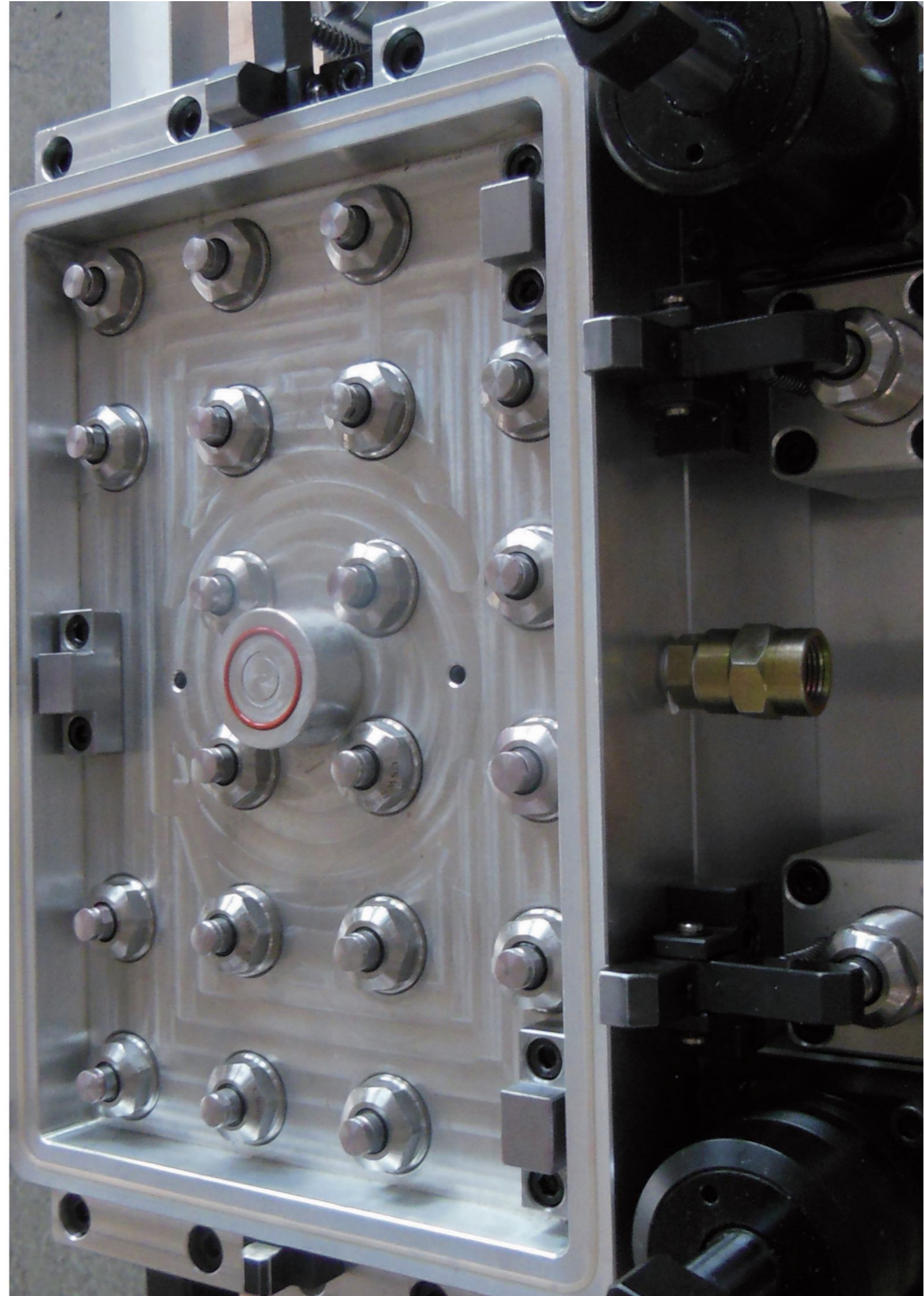

# CHSG

## CHSG焊接高压缸

## CHSG HYDRAULIC CYLINDER



### 订购标示法 ORDERING INDICATION

示例: CHSG-63/35-100-FA-W-B1-CO

CHSG	系列 Series	CHSG
63	油缸内径 Hydraulic cylinder inside diameter	Φ40, Φ50, Φ63, Φ80, Φ100, Φ125, Φ150, Φ180, Φ200, Φ220, Φ250
35	活塞杆径 Piston rod diameter	Φ25, Φ30, Φ35, Φ45, Φ55, Φ70/Φ80, Φ100, Φ120, Φ120, Φ140, Φ160
100	行程Stroke	
FA	缸体固定型式 Barrel fixing type	FA 前法兰型 Front flange
		FB 后法兰 Rear flange
		TC 铰轴 Cardinal axes
W	缸体固定型式 Barrel fixing type	C1 耳环通孔 Eye through port
		C2 耳环带衬套 Eye with bush
		C3 耳环带关节轴承 Eye with spherical plain bearing
B1	活塞杆端 连接方式 Piston on rod end connection method	W 外螺纹 Exterior thread
		N 内螺纹 Inner thread
B1	活塞杆端 连接方式 Piston on rod end connection method	B1 耳环通孔 Eye through port
		B2 耳环带衬套 Eye with bush
		B3 耳环带关节轴承 Eye with spherical plain bearing

图 1-1 Drawing 1-1

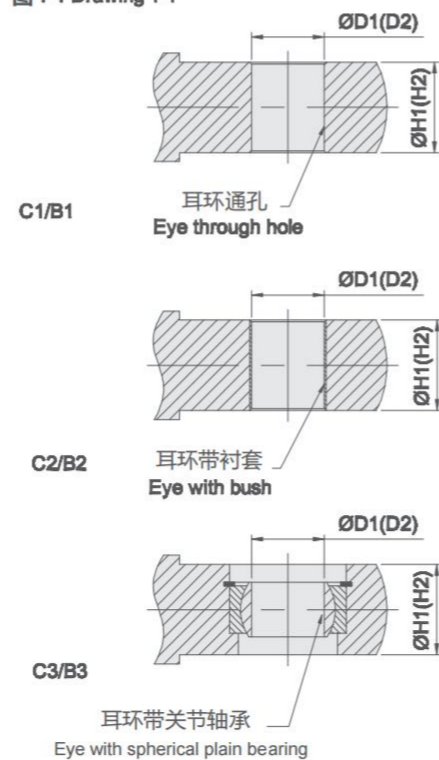

CO	阀配件 alve accessories	空白: 无 CB: 带双向平衡 (抗衡) 阀 CO: 带双向液控单向阀 Blank: No CB: With modular counter balance valve CO: With modular pilot operated check valve	<p>注:带双向平衡(抗衡)阀或带双向液控单向阀,适用于外负荷变化而要求行走速度平稳、容易控制、锁紧时间较长、防止重物因自重下落、防止油管爆裂油缸下落                      Note: With modular counter balance valve or with modular pilot operated check valve are applicable to make sure the cylinder working steadily,easy to control, long fasten time, not falling because of dead weight ,and not falling because of pipe burst when external load changes.</p>
----	----------------------------	---	---

### 大型油压缸特性资料 Specifications

油缸内径 Hydraulic cylinder inside diameter(mm)	Φ40 Φ50 Φ63 Φ80 Φ100 Φ125 Φ150 Φ180 Φ200 Φ220 Φ250
使用流体 Usable fluid	Recommended ISO-VG-32 hydraulic oil equivalent to ISO viscosity grade
缸管材质 Material of cylinder barrel	碳钢管 Carbon steel STKM-13A~C
使用压力范围 The range of pressure(MPa)	10~210 kgf/cm <sup>2</sup>
使用速度范围 The range of speed (mm/sec)	8~500(mm/sec)
使用温度范围 Range of temperature(°C)	-30 ~ +100 (°C)

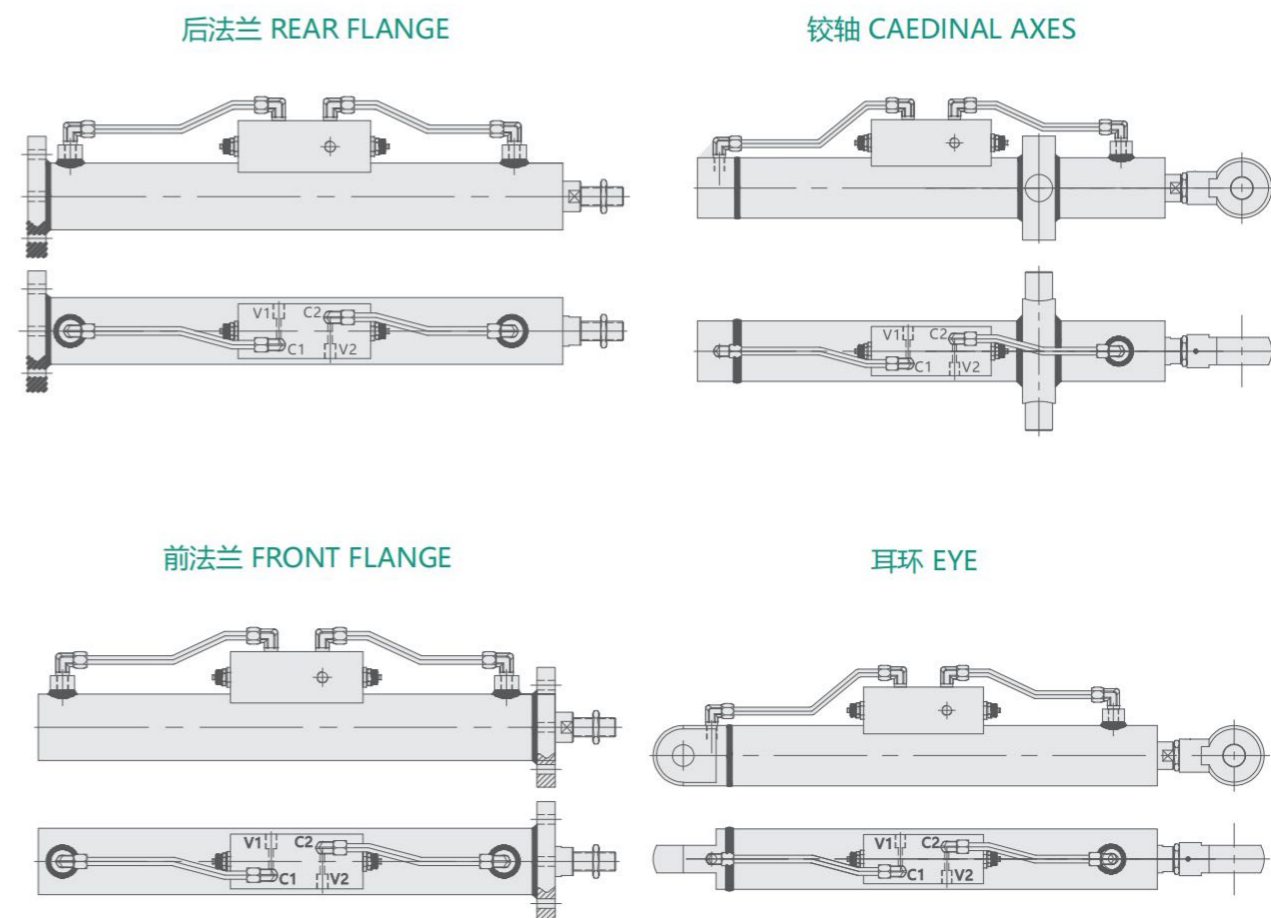

后耳环、内牙 REAR EYE INTERIOR THREAD

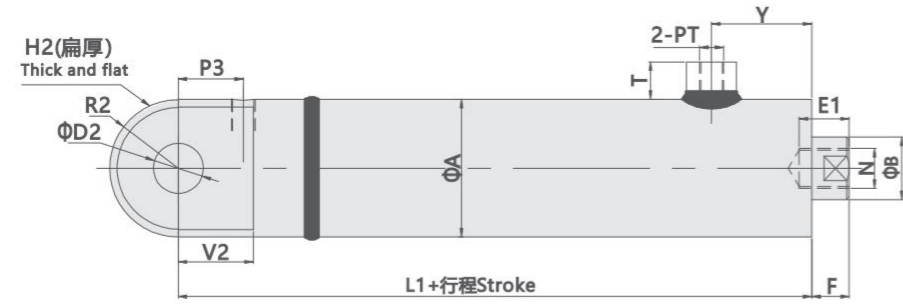

后耳环、外牙 REAR EYE EXTERIOR THREAD

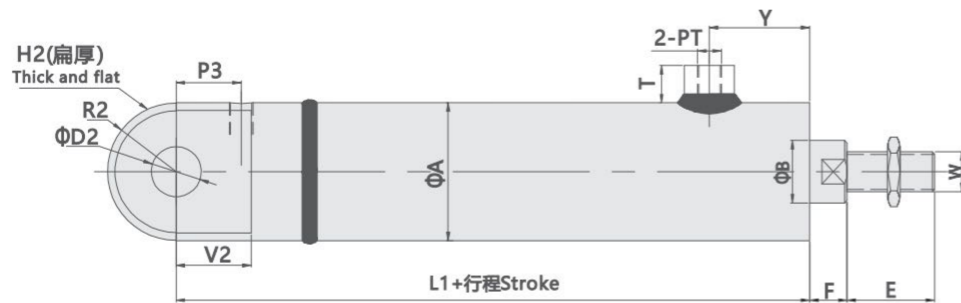

后耳环、前耳环 REAR EYE FRONT EYE

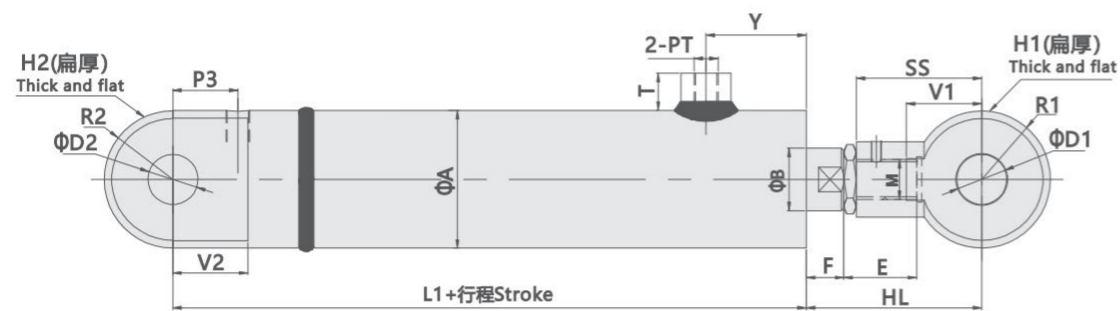

Unit:mm

HSG系列油缸外形尺寸 Dimension table

BORE	A	B	N	W	E	E1	F	SS	V1	V2	Y	P3	T	PT	H1	H2	R1	R2	D1	D2	HL	L1
Φ40	55	25	M16×1.5	M16×1.5	35	20	15	50	30	30	40	26	15	3/8"	25	25	25	25	20	20	80	153
Φ50	65	30	M20×1.5	M24×1.5	35	25	20	60	40	40	45	34	15	3/8"	35	35	35	35	30	30	95	173
Φ63	83	35	M27×1.5	M30×1.5	40	33	20	65	40	40	45	34	15	3/8"	35	35	35	35	30	30	100	173
Φ80	102	45	M30×1.5	M39×1.5	50	40	20	80	50	50	55	44	20	1/2"	45	45	45	45	40	40	115	244
Φ100	127	55	M42×2	M48×1.5	50	45	25	110	65	65	65	60	20	1/2"	60	60	60	60	50	50	150	265
Φ125	152	70/80	M52×2	M64×2	60	55	30	140	65	65	78	67	25	3/4"	60	60	60	60	50	50	190	297
Φ150	180	100	M68×2	M80×2	80	70	35	160	75	75	75	65	25	3/4"	70	70	70	70	60	60	215	315
Φ180	219	120	M85×2	M90×2	100	90	40	190	85	85	90	85	30	1"	80	80	80	80	70	70	255	390
Φ200	245	120	M85×3	M90×2	100	90	40	210	95	95	105	100	30	1"	90	90	90	90	80	80	275	440
Φ220	273	140	M105×3	M120×3	120	100	50	220	105	105	105	190	35	1-1/4"	90	90	90	90	90	90	300	450
Φ250	299	160	M140×3	M140×3	140	110	50	230	115	115	125	225	35	1-1/4"	110	110	110	110	100	100	300	500

前法兰、内牙 FRONT FLANGE INTERIOR THREAD

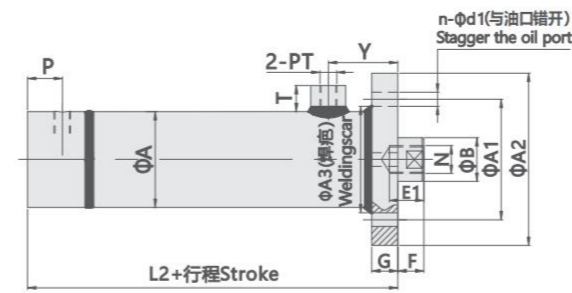

前法兰、外牙 REAR FLANGE EXTERIOR THREAD

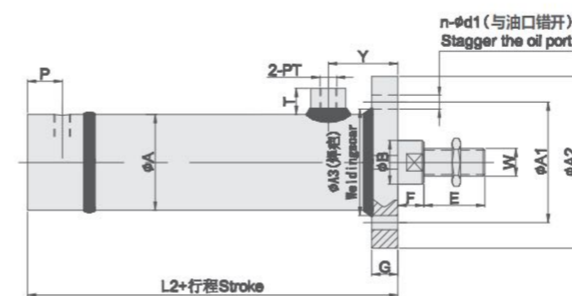

后法兰、内牙 REAR FLANGE INTERIOR THREAD

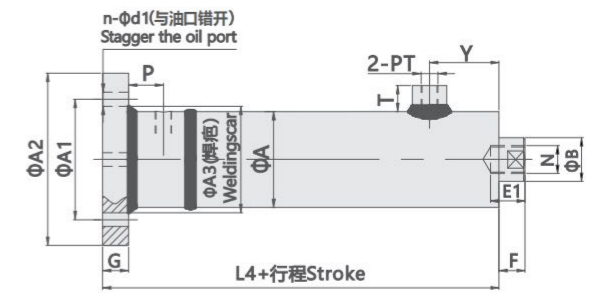

后法兰、外牙 REAR FLANGE EXTERIOR THREAD

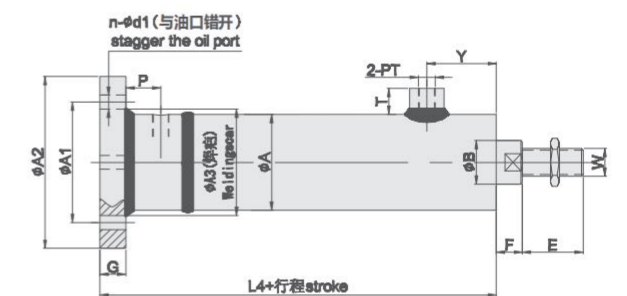

前法兰、前耳环 FRONT FLANGE FRONT EYE

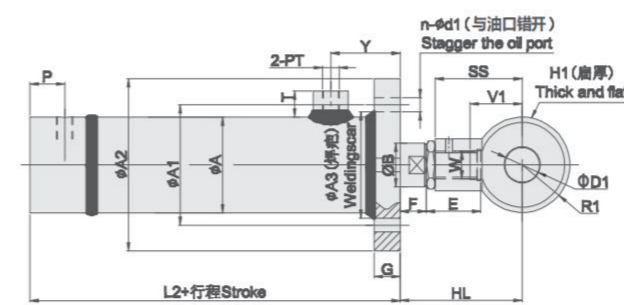

后法兰、前耳环 REAR FLANGE FRONT EYE

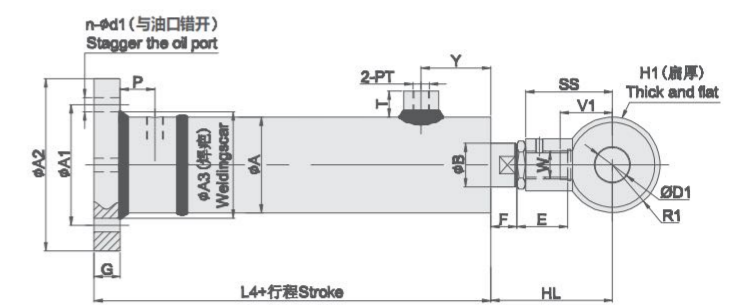

Unit:mm

HSG系列油缸外形尺寸 Dimension table

BORE	A	B	N	W	E	E1	F	G	A1	A2	A3	n-d1	SS	V1	Y	P	T	PT	H1	R1	D1	HL	L2	L4
Φ40	55	25	M16×1.5	M16×1.5	35	20	15	15	80	99	65	6-Φ8	50	30	40	20	15	3/8"	25	25	20	80	113	128
Φ50	65	30	M20×1.5	M24×1.5	35	25	20	15	90	109	75	6-Φ10	60	40	45	20	15	3/8"	35	35	30	95	123	138
Φ63	83	35	M27×1.5	M30×1.5	40	33	20	17	110	128	100	6-Φ10	65	40	45	20	15	3/8"	35	35	30	100	128	145
Φ80	102	45	M30×1.5	M39×1.5	50	40	20	25	145	173	118	6-Φ14	80	50	55	25	20	1/2"	45	45	40	115	164	189
Φ100	127	55	M42×2	M48×1.5	50	45	25	25	180	207	145	6-Φ18	110	65	65	25	20	1/2"	60	60	50	150	184	209

前法兰、内牙  
FRONT FLANGE INTERIOR THREAD

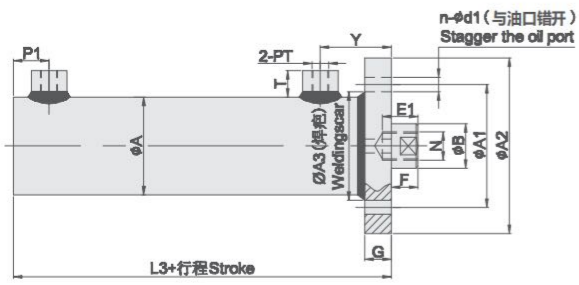

后法兰、内牙  
REAR FLANGE INTERIOR THREAD

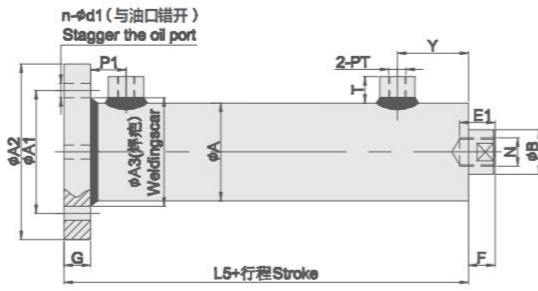

(Φ40-Φ100缸径) 铰轴、内牙  
(Φ40-Φ100BORE) CARDINAL AXES  
INTERIOR THREAD

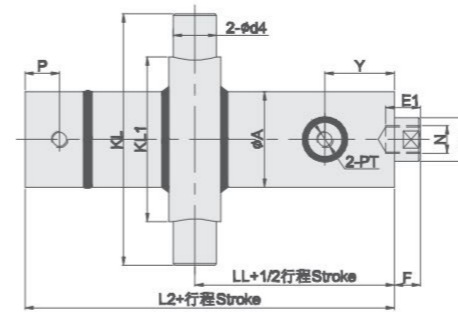

(Φ125-Φ250缸径) 铰轴、内牙  
(Φ125-Φ250BORE) CARDINAL AXES  
INTERIOR THREAD

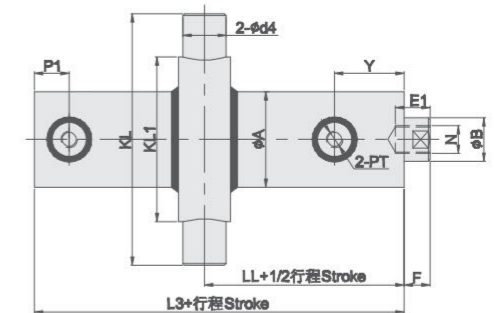

前法兰、外牙  
FRONT FLANGE EXTERIOR THREAD

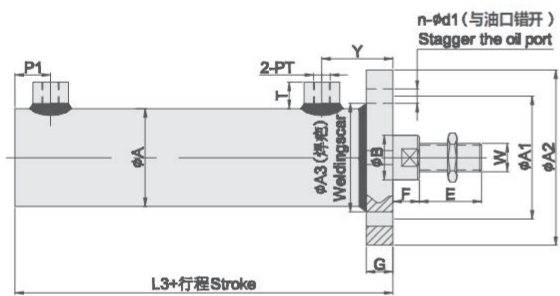

后法兰、外牙  
REAR FLANGE EXTERIOR THREAD

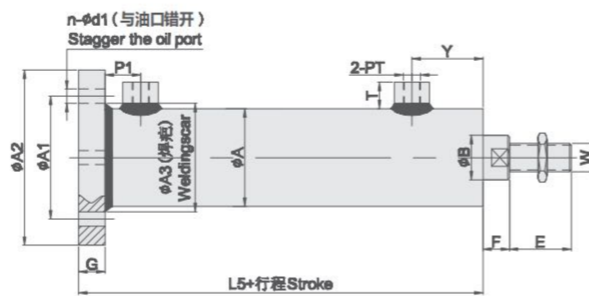

(Φ40-Φ100缸径) 铰轴、外牙  
(Φ40-Φ100BORE) CARDINAL AXES  
EXTERIOR THREAD

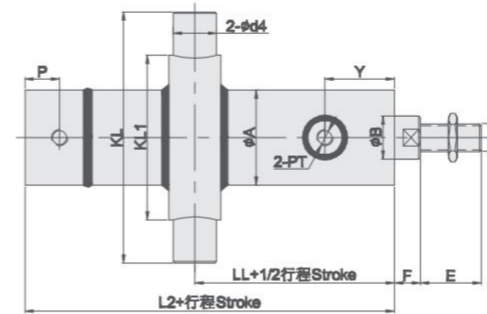

(Φ125-Φ250缸径) 铰轴、外牙  
(Φ125-Φ250BORE) CARDINAL AXES  
EXTERIOR THREAD

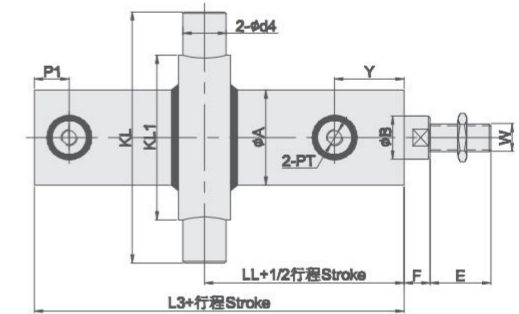

前法兰、前耳环  
FRONT FLANGE FRONT EYE

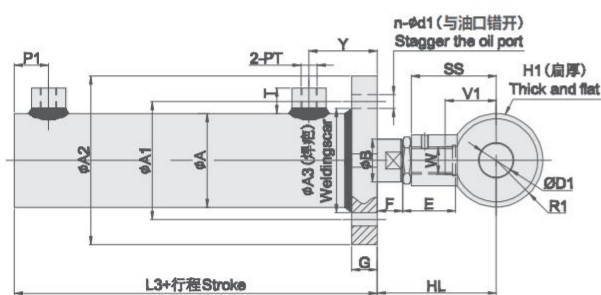

后法兰、前耳环  
REAR FLANGE FRONT EYE

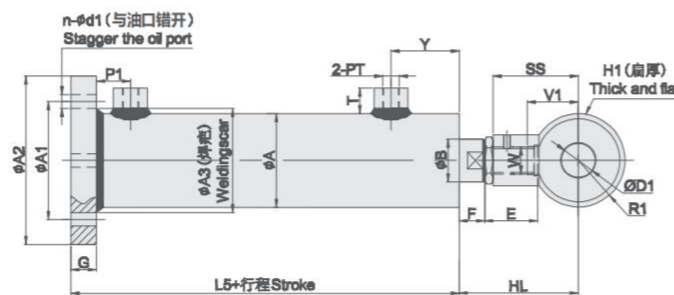

(Φ40-Φ100缸径) 铰轴、前耳环  
(Φ40-Φ100BORE) CARDINAL AXES  
FRONT EYE

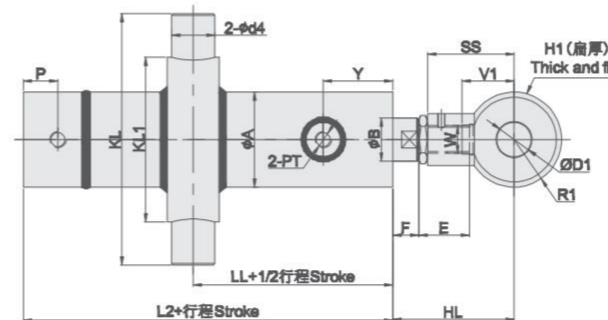

(Φ125-Φ250缸径) 铰轴、前耳环  
(Φ125-Φ250BORE) CARDINAL AXES  
FRONT EYE

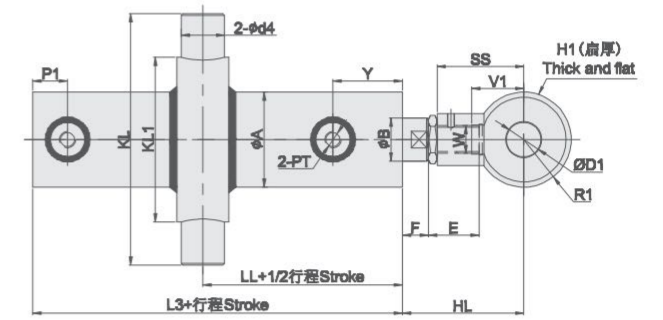

Unit:mm

HSG系列油缸外形尺寸 Dimension table

BORE	A	B	N	W	E	E1	F	G	A1	A2	A3	n-d1	SS	V1	Y	P1	T	PT	H1	R1	D1	HL	L3	L5
Φ125	152	70/80	M52×2	M64×2	60	55	30	30	210	237	170	8-Φ18	140	65	78	45	25	3/4"	60	60	50	190	210	240
Φ150	180	100	M68×2	M80×2	80	70	35	40	245	282	200	8-Φ22	160	75	75	55	25	3/4"	70	70	60	215	235	275
Φ180	219	120	M85×2	M90×2	100	90	40	50	285	322	240	8-Φ24	190	85	90	70	30	1"	80	80	70	255	395	345
Φ200	245	120	M85×3	M90×2	100	90	40	60	320	362	270	8-Φ26	210	95	105	85	30	1"	90	90	80	275	335	395
Φ220	273	140	M105×3	M120×3	120	100	50	60	355	402	300	8-Φ29	220	105	105	85	35	1-1/4"	90	90	90	295	345	405
Φ250	299	160	M140×3	M140×3	140	110	50	80	390	447	330	8-Φ32	230	115	125	110	35	1-1/4"	110	110	100	305	385	465

Unit:mm

HSG系列油缸外形尺寸 Dimension table

BORE	A	B	N	W	E	E1	F	SS	P1	V1	Y	P	R1	PT	D1	H1	HL	KL	KL1	d4	LL	L2	L3	最小行程
Φ40	55	25	M16×1.5	M16×1.5	35	20	15	50	-	30	40	20	25	3/8"	20	25	80	145	95	25	65	113	-	50
Φ50	65	30	M20×1.5	M24×1.5	35	25	20	60	-	40	45	20	35	3/8"	30	35	95	155	105	30	70	123	-	50
Φ63	83	35	M27×1.5	M30×1.5	40	33	20	65	-	40	45	20	35	3/8"	30	35	100	171	115	30	70	128	-	50
Φ80	102	45	M30×1.5	M39×1.5	50	40	20	80	-	50	55	25	45	1/2"	40	45	115	185	125	40	90	164	-	50
Φ100	127	55	M42×2	M48×1.5	50	45	25	110	-	65	65	25	60	1/2"	50	60	150	230	155	50	110	184	-	60
Φ125	152	70/80	M52×2	M64×2	60	55	30	140	45	65	78	-	60	3/4"	50	60	190	260	185	50	120	-	210	80
Φ150	180	100	M68×2	M80×2	80	70	35	160	55	75	75	-	70	3/4"	60	70	215	305	215	60	130	-	235	80
Φ180	219	120	M85×2	M90×2	100	90	40	190	70	85	90	-	80	1"	70	80	255	360	255	70	160	-	295	80
Φ200	245	120	M85×3	M90×2	100	90	40	210	85	95	105	-	90	1"	80	90	275	405	285	80	180	-	335	80
Φ220	273	140	M105×3	M120×3	120	100	50	220	85	105	105	-	90	1-1/4"	90	90	295	455	320	90	180	-	345	80
Φ250	299	160	M120×3	M140×3	140	110	50	230	110	115	125	-	110	1-1/4"	100	110	305	500	350	100	205	-	385	90

# CHK

## 柱型模具油压缸

### CHK COLUMN-TYPE HYDRAULIC CYLINDER

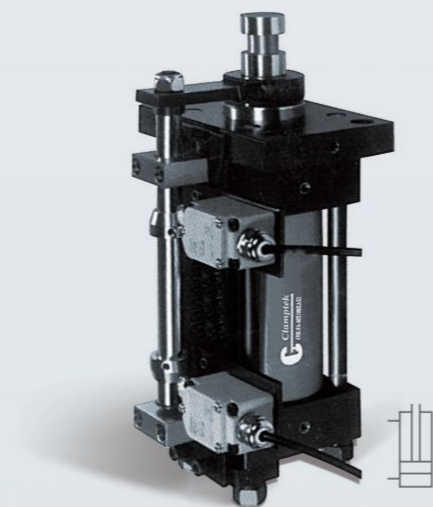

#### 产品说明

CHK柱型模具油为通用型中高压油缸，特别适用于压铸模具领域，通用性广泛。

CHK柱型模具油缸增加了导出系统可准确的控制油缸行程。CHK柱型模具油缸内部增加了缓冲装置提高了油缸及模具行程滑块的使用寿命。

最大操作压力：140 kgf/cm<sup>2</sup>

最小操作压力：10 kgf/cm<sup>2</sup>

#### FEATURES

CHK column-type hydraulic cylinder is a medium and high-voltage cylinder which has wide application. It is especially applicable in the field of die-casting mould.

CHK column-type hydraulic cylinder adds guiding system to controls stroke adequately during operating. CHK column-type hydraulic cylinder internal adds buffer device to prolong service life of the cylinder and slide block.

Max.operating pressure: 140 kgf/cm<sup>2</sup>

Min.operating pressure: 10 kgf/cm<sup>2</sup>

#### 注意事项

可接受订制，欢迎与本公司洽询。

如客户使用工况的温度超过标准使用范围，则需订制高温密封件，请下单前与我司联系。

#### NOTE

Orders with customized request are available, welcome to contact us.

If the temperature of the working environment used by the customer exceeds the standard operating range, high-temperature sealing parts need to be customized. Please contact us before placing an order.

#### 订购标示法 ORDERING INDICATION

示例: CHK-FA80-100D-S2T

CHK	系列 Series	CHK
FA	安装型式 Fixing type	FA前法兰安装
80	油缸内径 Hydraulic cylinder inside diameter	Φ40, Φ50, Φ63, Φ80, Φ100, Φ125, Φ150, Φ180, Φ200, Φ220, Φ250.
100	行程 Stroke	依客户要求
D	活塞杆连接方式 Piston connection type	A型: 脖子型 B型: 外牙型 C型: 内牙型 D型: 窄圆脖子型 E型: 窄圆外牙型 F型: 宽圆型
S2	行程开关数量	S1: 一个 S2: 两个 S1 of 1 pc, S2 of 2 pcs
T	耐高温型	最高使用温度150°C

使用流体:普通矿物油基液压油 (相当于ISO-VG-32)

Recommended ISO-VG-32 hydraulic oil equivalent to ISO viscosity grade

FA(特殊型)尺寸参考图 FA(SPECIAL TYPE)REFERENCE DRAWING

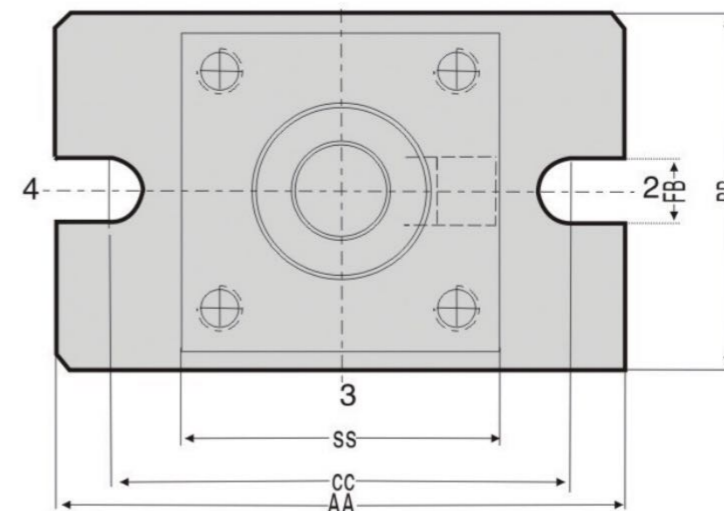

Unit:mm

BORE	活塞杆径	AA	BB	CC	FB	SS
40	18	118	70	94	14	65
50	22	135	85	108	18	75
63	28	160	100	130	18	90
80	36	185	122	150	22	110
100	45	220	145	180	26	135
125	56	255	175	210	33	165
150	70	305	212	254	33	196
180	80	365	250	300	39	236
200	90	405	280	335	42	265
220	100	470	335	395	45	310
250	110	515	355	425	48	330

注:AA.BB.CC.FB是参考值，可限据客户要求制作。

#### 柱型模具油压缸特性资料 Specifications

油缸内径 Hydraulic cylinder inside diameter(mm)	Φ40	Φ50	Φ63	Φ80	Φ100	Φ125	Φ150	Φ180	Φ200	Φ220	Φ250
缸管材质 Material of cylinder barrel	碳钢管 Carbon steel STKM-13C										
最小缓冲行程 Min. Cushion stroke(mm)	50	50	50	50	80	80	80	100	100	100	100
使用温度范围 Range of temperature(°C)	-10 ~ +70 (°C)										

注:油缸行程小于最小缓冲行程时不配缓冲装置

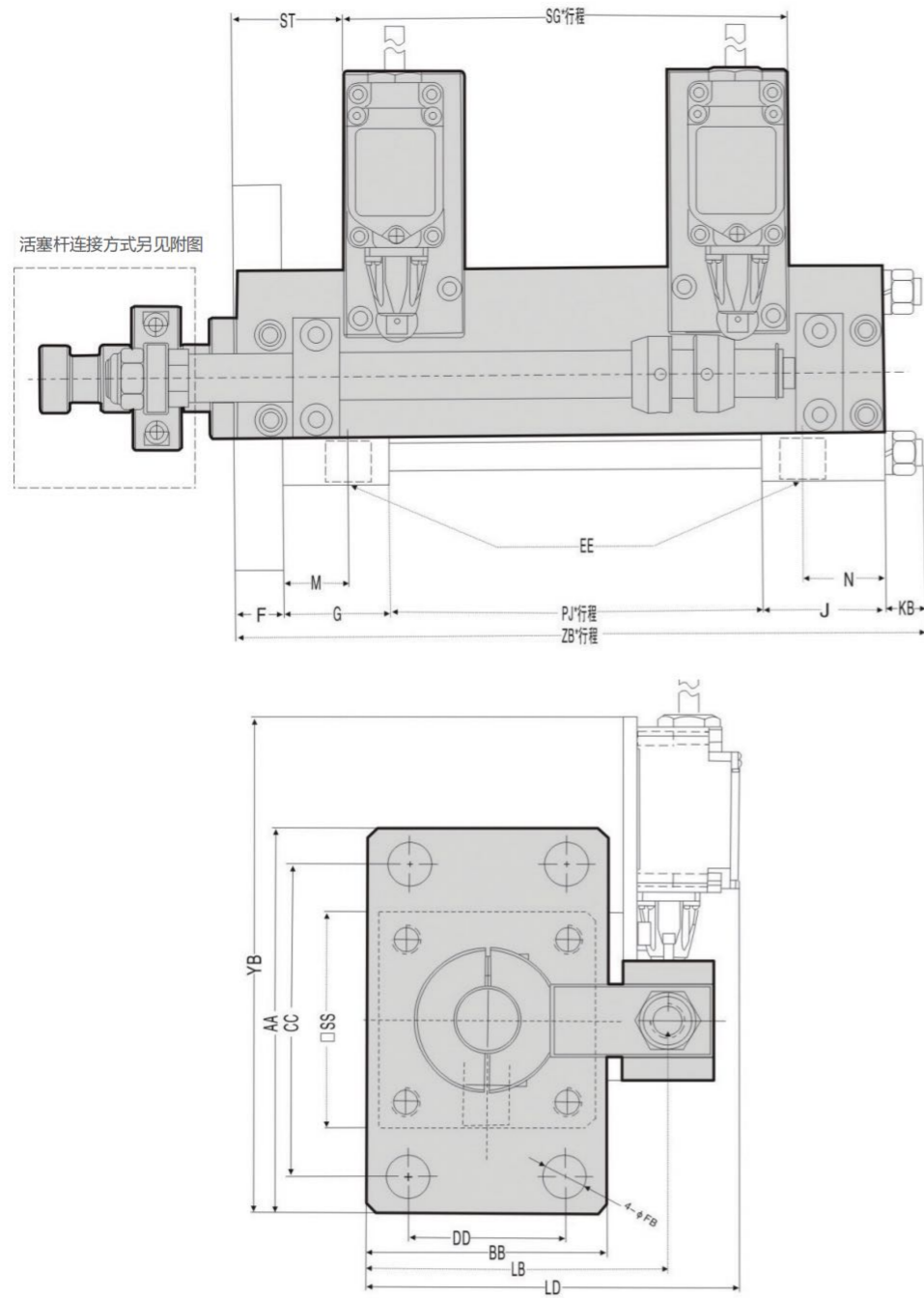

活塞杆连接方式另见附图

Unit:mm

BORE	活塞杆径	EE(PT)	M	N	F	G	J	KB	ST	AA	BB	CC	DD	LB	SS	LD	ΦFB	YB	SG	PJ	ZB
40	18	3/8	17	13	18	38	28	15	41	118	70	94	40	95	65	125	10	186	83	46	145
50	22	3/8	29	21	20	44	36	15	46	135	85	108	50	110	75	140	14	194	84	54	169
63	28	1/2	27	19	20	44	36	16	46	160	100	130	65	125	90	155	18	207	84	54	170
80	36	1/2	28	22	25	48	42	23	46	185	122	150	80	147	110	177	18	219	84	58	196
100	45	3/4	30	20	30	52	42	25	46	220	145	180	100	170	135	200	22	237	84	70	218.5
125	56	3/4	38	28	32	58	48	29	46	255	175	210	125	200	165	230	26	254	84	87	254
150	70	3/4	42	30	37	62	50	34	46	305	212	254	150	237	196	267	33	279	84	93	275.5
180	80	1	52	38	45	74	60	39	46	365	250	300	180	275	236	305	33	309	84	106	324
200	90	1	49	33	50	78	62	43	46	405	280	335	210	305	265	335	39	329	84	118	351
220	100	1-1/4	48	36	60	82	70	50	46	470	335	395	230	360	310	390	42	362	84	158	419.5
250	110	1-1/4	56	42	65	92	78	51	46	515	355	425	250	380	330	410	45	384	84	138	423.5

CHK柱型模具油缸活塞杆连接方式的尺寸图  
CONNECTION DRAWING OF SHAFT FOR CHK COLUMN-TYPE HYDRAULIC CYLINDER

A型-脖子型

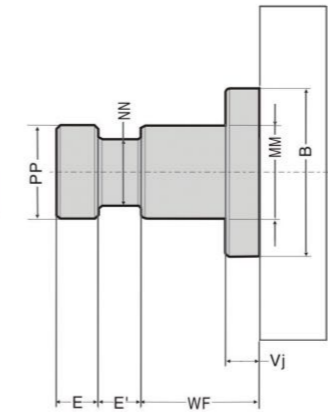

B型-外牙型

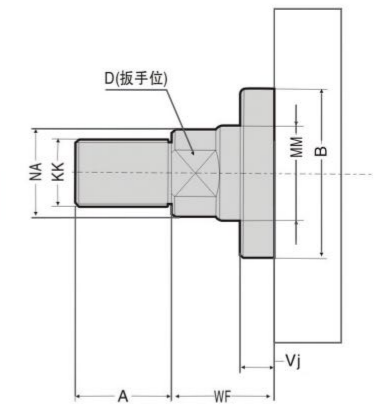

D型-窄圆脖子型

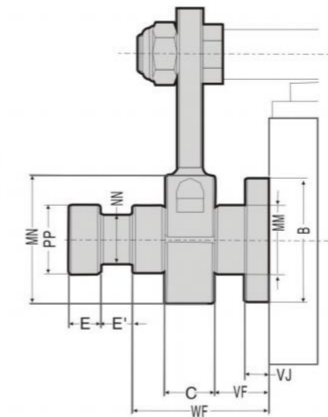

E型-窄圆外牙型

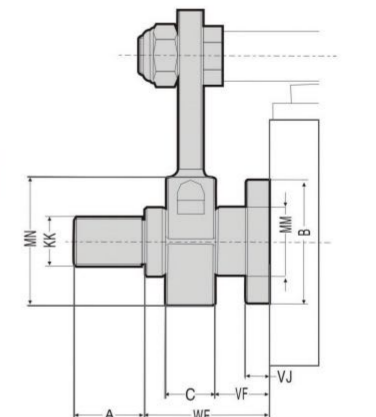

C型-内牙型

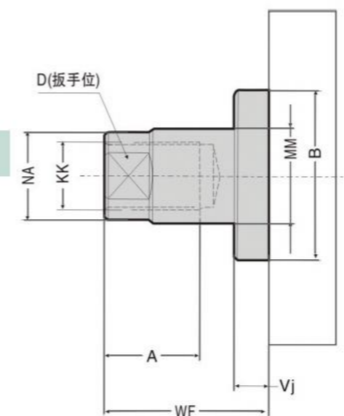

F型-宽圆型

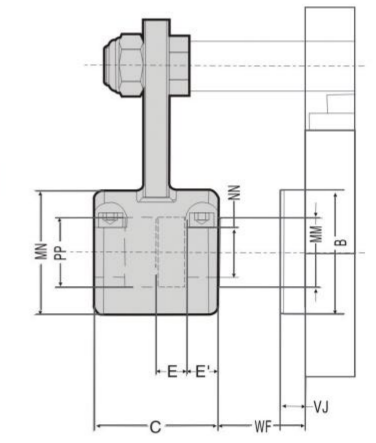

Unit:mm

BORE	活塞杆径	ΦPP	ΦNN	E	E'	KK	A	ΦB	D	ΦNA	VJ	VF	WF				C				ΦMN	
													A/F型	B型	C型	D型	E型	D/E型	F型	D/E型	F型	F型
40	18	18	13	12.5	12.5	M14xP1.5	18	36	15	17	5	7	30	27	35	40	37	20	50	50	40	
50	22	22	16	12.5	12.5	M16xP1.5	22	42	18	21	10	12	35	28	41	45	38	20	50	55	42	
63	28	28	20	12.5	12.5	M20xP1.5	28	50	22	26	10	12	35	30	48	45	40	20	50	60	46	
80	36	36	25	15	15	M27xP2.0	36	65	30	34	10	12	40	30	51	50	40	20	60	65	54	
100	45	45	31	15	15	M33xP2.0	45	70	39	43	10	12	45	35	57	55	45	20	60	80	62	
125	56	56	38	20	20	M42xP2.0	56	75	48	56	10	12	50	40	57	60	50	20	80	90	75	
150	70	70	46	25	25	M48xP2.0	63	90	62	68	10	12	60	54	57	70	64	20	100	100	94	
180	80	80	55	25	25	M56xP2.0	75	115	70	78	10	12	65	60	57	75	70	20	100	106	116	
200	90	90	60	30	30	M64xP3.0	85	120	80	88	10	12	70	85	57	80	75	20	120	110	130	
220	100	100	66	35	35	M72xP3.0	85	145	90	98	10	12	80	85	57	90	95	20	140	130	140	
250	110	110	72	40	40	M80xP3.0	95	160	100	108	10	12	80	85	57	90	95	20	160	150	150	

# CP

## 同步油缸

### CP SYNCHRONOUS CLAMP

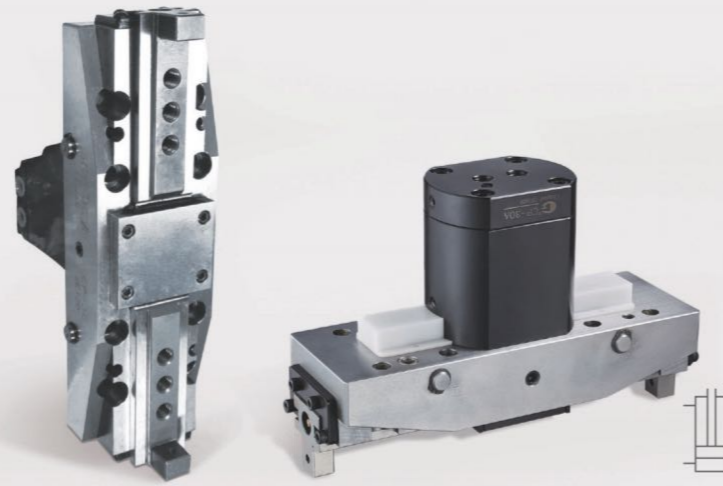

#### 产品特性

曲柄型二滑块同步油缸,滑块行程长。  
折动面均经硬化及精密研磨,并直接润滑。  
高夹持精度,防尘效果特佳。

最大操作压力: 35kgf/cm<sup>2</sup>  
最小操作压力: 10kgf/cm<sup>2</sup>

#### FEATURES

It's a CRANK type 2 slider synchronous clamp cylinder with long slider stroke.  
Matching surface of all parts hardened, ground and lubricated directly. Construction of high rigidity and high clamping accuracy.

Max. operating pressure: 35kgf/cm<sup>2</sup>  
Min. operation pressure: 10kgf/cm<sup>2</sup>

型号 Model	CP-20 CP-20W	CP-30A CP-30AW	CP-30 CP-30W	CP-50 CP-50W	CP-70 CP-70W
推出受压面积 Eff. piston area clamp (cm <sup>2</sup> )	28.27	28.27	28.27	38.48	50.26
滑块行程 Slider stroke (mm)	20	30	30	50	70
理论夹持力 (35kgf/cm <sup>2</sup> ) Clamping force at 35kgf/cm <sup>2</sup>	1653	1806	1806	2071	2603
使用温度范围 Range of temperature(°C)	-10 ~ + 70 (°C)				

使用流体: 普通矿物油基液压油 (相当于ISO-VG-32)  
Recommended ISO-VG-32 hydraulic oil equivalent to ISO viscosity grade  
W: 表示防尘盖

#### CP 外形尺寸

注: 具体外形参见前页产品图片

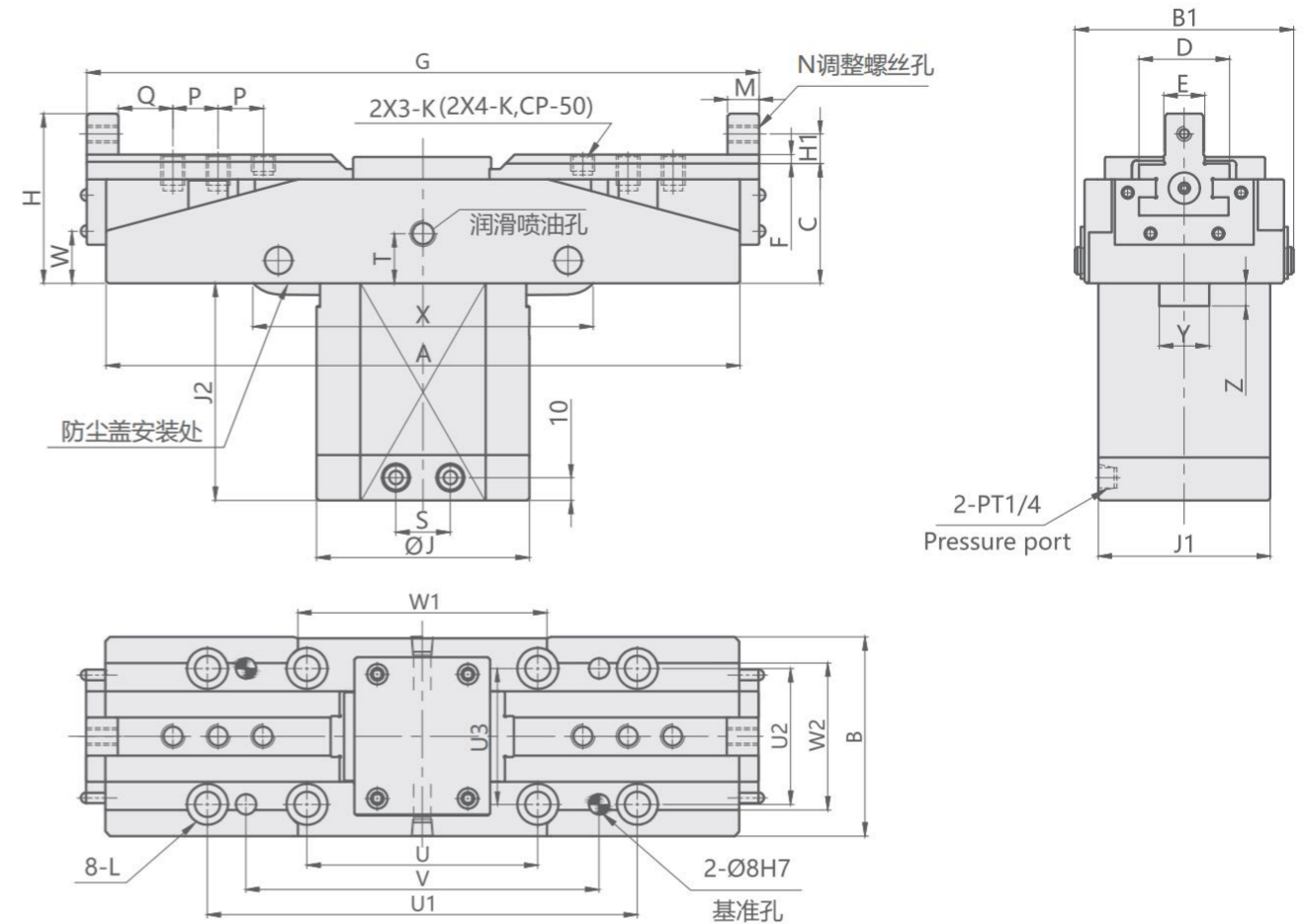

Unit:mm

MODEL	A	B	B1	C	D	E(h6)	F	G	H	H1	J	J1	J2	K	L	M	N	
								MAX	MIN									
CP-20	215	88	96	53	40	18	4	249	229	75	13	94	76	83.5	M10xP1.5	M10	12	M6xP1
CP-30A	250	88	96	53	40	18	4	295	265	75	13	94	76	96	M10xP1.5	M10	14	M6xP1
CP-30	280	88	96	53	40	22	4	327	297	75	13	94	76	96	M12xP1.75	M10	14	M6xP1
CP-50	300	110	115	65	50	28	5	369	319	90	15	105	-	120	M12xP1.75	M10	16	M8xP1.25
CP-70	346	120	126	89	55	32	5	429	359	114	15	115	-	146	M14xP2.0	M12	16	M8xP1.25

Unit:mm

MODEL	P	Q	S	T	U	U1	U2	U3	V	W	W1	W2	X	Y	Z	含防尘盖		
																X	Y	Z
CP-20	18	20	24	22	102	190	60	-	156	32	110	65	150	22	4	171	41	7
CP-30A	20	24	25	22	102	190	60	-	156	20	120	65	156	22	6	181	41	15
CP-30	20	24	25	22	102	190	60	-	156	23	110	65	156	22	6	181	41	15
CP-50	21	28	30	32	105	230	85	-	195	22	140	88	180	30	10	184	50	18
CP-70	23	28	30	56	118.5	276	96	95	240	40	155	90	218	29	15	240	55	27

# CFVA

对心夹

## CFVA CLAMPING CYLINDER



### 产品特性

二滑块同步油缸，具有高精度重复定位行程。传动面经硬化及精密研磨，并直接润滑。高夹持精度，防尘效果特佳。

最大操作压力：70 kgf/cm<sup>2</sup>  
最小操作压力：15 kgf/cm<sup>2</sup>

### FEATURES

2 Slider synchronous clamp cylinder, with high precision repeated positioning stroke. Transmission surface of all parts hardened, ground and lubricated directly. Construction of high rigidity and high clamping accuracy.

Max. operating pressure: 70 kgf/cm<sup>2</sup>  
Min. operating pressure: 15 kgf/cm<sup>2</sup>

### 注意事项

夹紧及放松动作速度需适当放缓。可接受订制，欢迎与本公司洽询。

### NOTE

The speed of clamping / undamping action needs to be slowed down appropriately. Customization is available upon request, please contact us for more info.

### 订购标示法 ORDERING INDICATION

示例：CFVA-063

CFVA	系列 Series	CFVA
063	缸径 cylinder diameter	040/063/100

### 外形尺寸

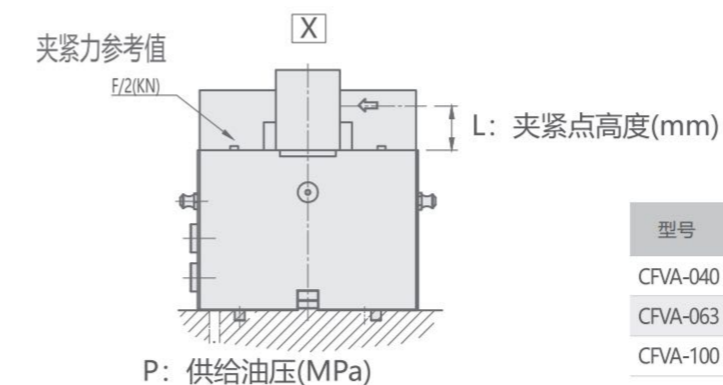
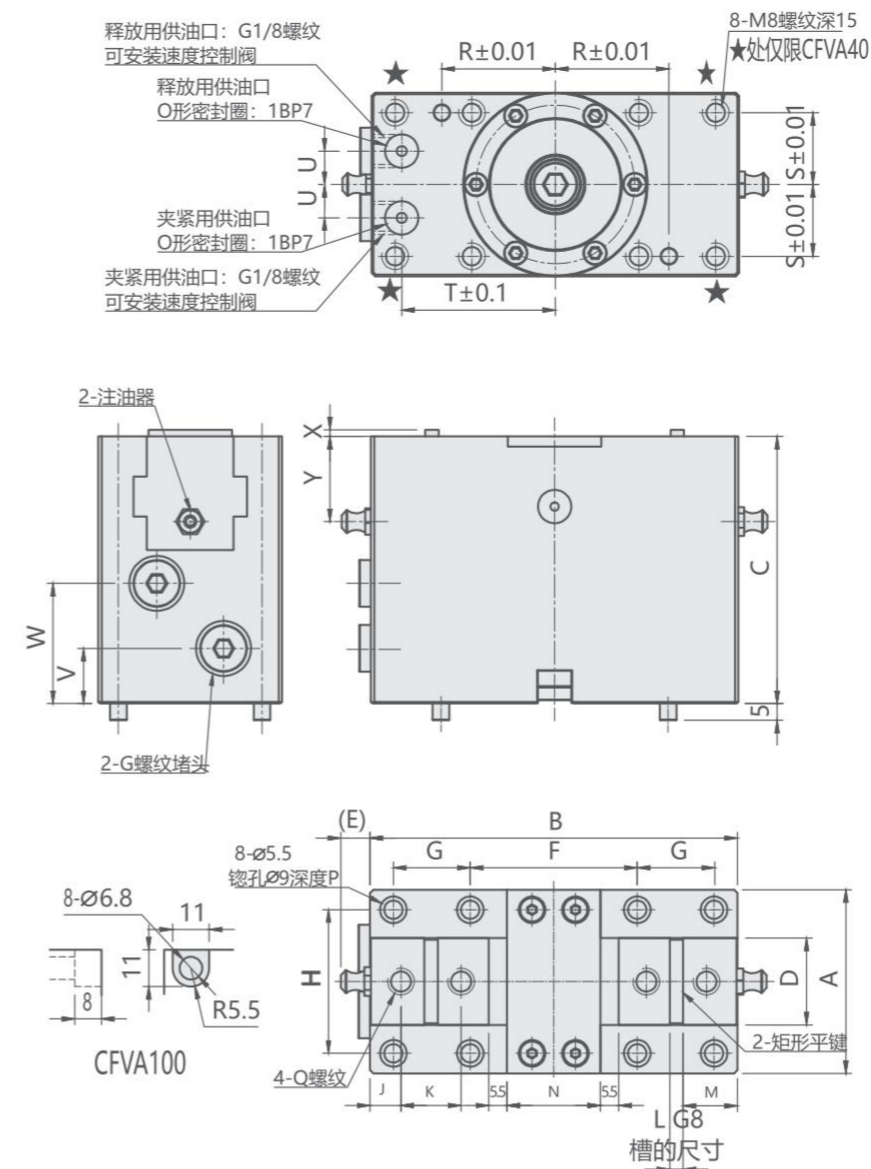

型号	夹紧力计算公式	供给油压P(MPa)	夹紧力(KN)	夹紧点高度L(mm)
CFVA-040	$F=(148 \cdot P)/(183+L)$	7	4.86	30
CFVA-063	$F=(272 \cdot P)/(204+L)$	7	8.14	30
CFVA-100	$F=(480 \cdot P)/(226+L)$	7	13.13	30

### 规格参数表 SPECIFICATIONS

型号	夹紧行程(单边)	总行程	推出容积	拉入容积	推出受压面积	拉入受压面积	使用温度范围	使用流体
CFVA-040	5	10	5.5	5.5	6.0	6.0	0°~+70°C	使用流体: 普通矿物油 基液压油(相当于 ISO-VG-32) Recommended ISO-VG- 32 hydraulic oil equivale nt to ISO viscosity grade
CFVA-063	5	10	9.1	9.1	10	10	0°~+70°C	
CFVA-100	5	10	14.4	14.4	15.8	15.8	0°~+70°C	

Unit:mm

型号 Model No	CFVA-040	CFVA-063	CFVA-100
A	50	55	60
B	100	110	120
C	72	80	85
D	23	26	28
E	9	15	15
F	45	50	65
G	20	23	20
H	39	43	49
J	7	9	9
K	18	18	22
L	4 <sup>+0.022</sup> <sub>+0.004</sub>	4 <sup>+0.022</sup> <sub>+0.004</sub>	5 <sup>+0.022</sup> <sub>+0.004</sub>
M	14	16	17.5
N	24	28	28
P	6	7	-
Q (公称*深度)	M6*12	M8*13	M10*15
R	32	35	42.5
S	19.5	21.5	24.5
T	41	46	51
U	9	10	10
V	15	16.5	17
W	31	36	36.5
X	2	2	2.5
Y	23.5	25.5	29.5
矩形平键	4*4*20	4*4*25	5*5*25

# CYTC

## 下拉式台钳

### CYTC PULL-DOWN BENCH VISE



#### 产品特性

单作用下压式夹钳，弹簧复位，板式连接，应用在边缘夹紧的场所，产生直进夹紧动作，配合下拉力将工件夹住下拉，下压力约为各自夹紧力的1/3，标准产品有锯齿状硬质钳口，管式连接供油。

最大操作压力:400kgf/cm<sup>2</sup>

#### PRODUCT FEATURE

Single-acting push-down clamp, spring return, gasket connection, is applied in edge clamping places, generating a direct clamping action, and in combination with the downward pulling force, the workpiece is clamped and pulled down. The downward force is approximately 1/3 of the respective clamping force. The standard product has a serrated hard jaw and a pipe connection for oil supply.

Max.operating pressure :400kgf/cm<sup>2</sup>

#### 注意事项

钳口和活塞通过接头连接避免了向活塞引入弯矩并延长夹具寿命，钳口和活塞通过接头连接避免了向活塞引入弯矩，并延长夹具寿命，上部用两个安装螺栓系紧，下部用四个保证在运行限度内最稳固。

#### NOTE

The jaw and the piston are connected through a joint, which avoids introducing bending moment to the piston and extends the fixture's life time. The upper part is fastened with two installation bolts, and the lower part is fastened with four bolts to ensure the most stable operation within the operating limit.

#### 规格参数表 SPECIFICATIONS

型号 MODEL	40MPa时夹持力 (KN)	行程D (mm)	用油量 (cm <sup>3</sup> )	重量 (g)
	20	8	4	2500
CYTC-S20	安装螺栓	最大扭矩(Nm)	最小复位力(N)	
	M12*80	72	160	

#### 外形尺寸 EXTERNAL DIMENSIONS

Unit:mm

型号 MODEL	A	B	C	D	E	F	G	H
	135	50	50	8	3	14	58	12.5
CYTC-S20	J	K	L	M	N	P	Q	R
	67	74	18	36	M8	12	14	G1/4

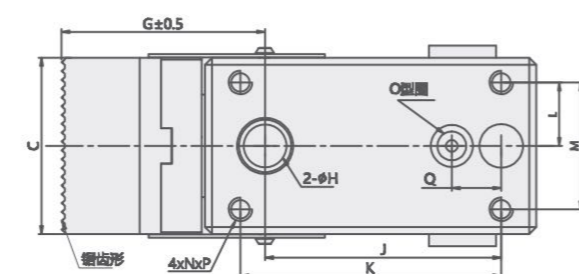
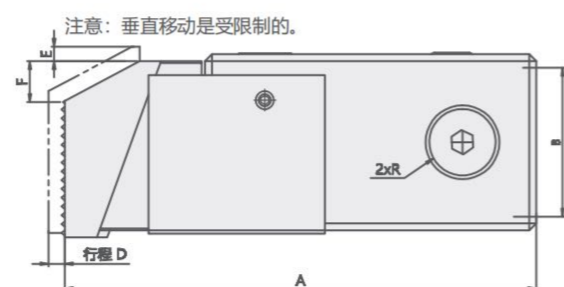

# ROA

## 夹紧油缸

### ROA CLAMPING CYLINDER



#### 夹紧油缸特性资料 Specifications

使用压力范围 The range of pressure(MPa)	0.5-10MPa
使用温度范围 Range of temperature(°C)	Range of temperature(°C) -10 ~ +60(°C)
使用速度范围 The range of speed (mm/sec)	The range of speed(mm/sec) 8 ~ 300(mm/sec)
工作流体 Power Fluid	滤清之标准液压油 Filtered oil

#### 订购标示法 ORDERING INDICATION

示例: ROA-50-125-FA-T

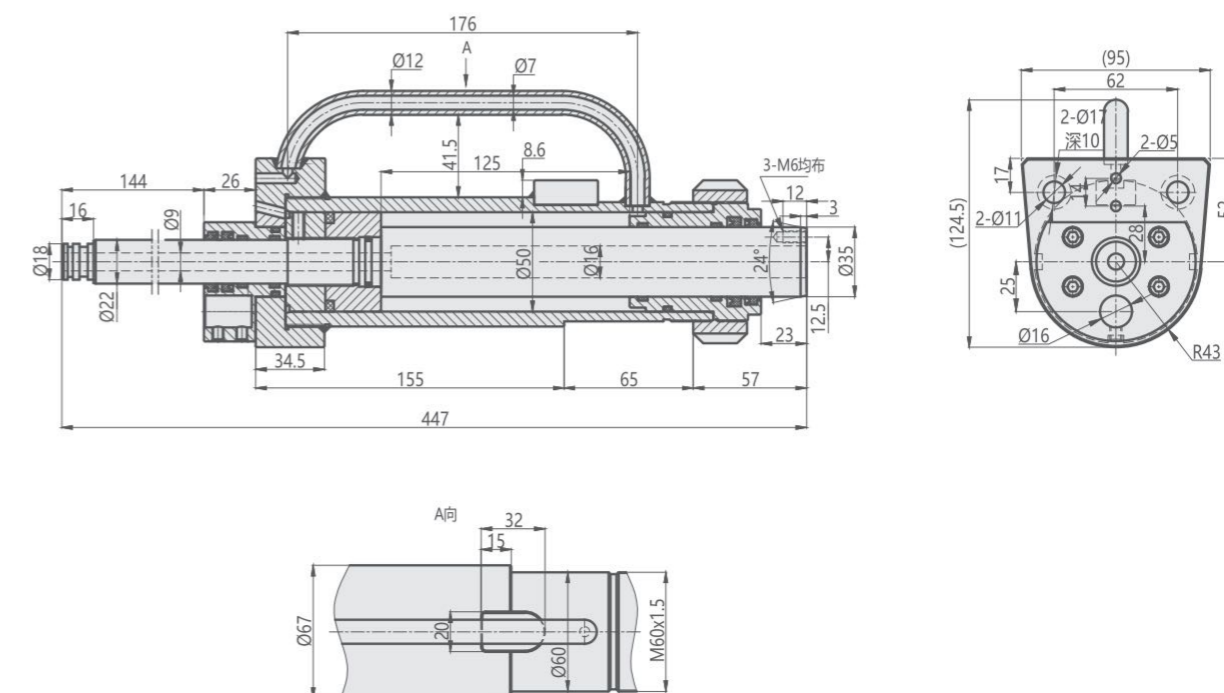

# 自动

## 平衡系统

# AUTO BALANCE SYSTEM



### 产品特性

无需外接动力,节省能源。  
可适应高转速时快速平稳提升下降,无噪音,改善配重油压系统之缺点。  
在加工过程可使精度及光洁度大幅提升,减去微震动,延长螺杆及电机使用寿命。  
安装简单。正确使用下,基本无需任何保养

### 订购标示法 ORDERING INDICATION

示例: HPT-30-08

HPT	氮气充填压力(MPa)
30	容积 (L)
08	系列编号

注: 氮气最大充填压力9MPa

订购时需一并提供下述咨询

- |                      |  |
|----------------------|--|
| 1.配重重量 _____ KG      | 6.配重油缸类型□活塞式□柱塞式   |
| 2.最大位移速度 _____ M/min | 7.配重缸入油方向□前盖入油□后盖入油                                      |
| 3.实际位移行程 _____ mm    | 8.如配重缸有特殊尺寸要求请提供相关图面或与本公司服务人员联络,若无特殊要求请参照本公司RO及HO系列产品尺寸。 |
| 4.配重油缸数量 _____ pcs   |  |
| 5.油管长度 _____ mm      |  |

\*Currently sold in Mainland China only.



图中红色虚线框中之充、排氮气阀 (C) 及其连接之充气管 (E) 为选配部件,标准产品不含此两项部件 (需另购)。

### 说明

- A. 出油口:连接油缸用
- B. 球阀:液压油开关, 逆时针方向为开, 氮气瓶与油缸油液互通; 顺时针方向为关, 氮气瓶与油缸油液截断。
- C. 充、排放气阀(选配部件, 需另购):氮气瓶充、排气工具。
- D. 耐震压力表:可显示系统压力。
- E. 充气管(选配部件, 需另购):一端连接氮气源, 另一端连接

- 充、排气阀, 作为氮气源与氮气瓶传输管道。
- F. 充、排气口:加气及泄压介面。
- G. 氮气瓶:储存液压力及氮气。
- H. 压力开关:当系统压力低于设定值时, 压力开关将输出信号, 提醒使用者及时充气补充压力。

### 搬运方法



### 压力开关设定

压力开关设定, 平衡系统上设有一压力开关, 当平衡系统压力大于设定值时:

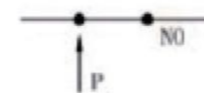

当平衡系统压力小于设定值时:



设定值出厂时会设定好贵公司机器所需压力值, 如需自行设定, 请用一字螺丝刀拆下保护帽, 内有一字螺丝槽, 顺时针旋转压力升高, 逆时针旋转压力降低, 请自行调到合适位置, 此处压力称为设定值。

### 压力开关接线说明:

- 1.压力开关使用电压为220V或DC24V, 拆除压力开关保护帽, 接入压力开关接线柱
- 2.开机后调节合适的设定值
- 3.设定值调节好之后装上保护帽

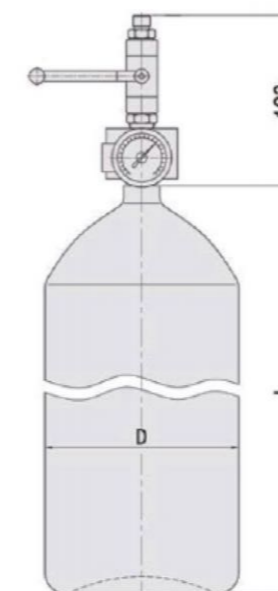

### 泄压步骤

- 1.先确定球阀为关闭状态。
- 2.取下充、排气口上之螺帽。
- 3.确定充、排气阀上截止阀为关闭状态后将充、排气阀正确安装于充、排气口上, 用扳手锁紧。
- 4.缓慢开启充、排气阀上之截止开关。
- 5.观察充、排气阀上之压力表, 当压力表缓慢降低至所需压力时将截止阀关闭, 卸下充、排气阀。
- 6.用肥皂水涂抹在充、排气口, 测试是否泄漏。
- 7.将充、排气口螺帽锁紧。

### 充气步骤

- 1.先确定球阀为关闭状态。
- 2.取下充、排气口上之螺帽。
- 3.确定充、排气阀上截止阀为关闭状态后将充、排气阀正确安装于充、排气口上用扳手锁紧。
- 4.使用充气管正确连接氮气源及充、排气阀。
- 5.开启氮气源开关, 并缓慢开启充、排气阀上截止阀。
- 6.观察充、排气阀上之压力表, 当压力缓慢升高至所需压力时将充、排气阀与氮气源截止阀关闭, 卸下充、排气阀。
- 7.用肥皂水涂抹在充、排气口, 测试是否泄漏。
- 8.将充、排气口螺帽锁紧。

### 使用注意事项

- 1.安装完成后球阀依逆时针方向缓慢旋转(严禁急速打开球阀)。
- 2.球阀扳手依逆时针缓慢旋转至45°位置后先暂停, 用手轻握油管, 会感觉液压油在管内流动。
- 3.当液压油慢慢充满管路及油缸后再完全打开球阀, 使油缸的出力与主轴重量达到平衡。
- 4.机器运转过程中禁止关闭球阀, 球阀上扳手请取下放置工具箱, 避免因误触发生故障或危险。

容积	瓶身高度L	外径D
6.3L	525	140
10L	705	152
20L	740	219
30L	1010	219
40L	1350	219
60L	1350	267
80L	1740	267

# 非标工程缸(重型油压缸)

Non-standard hydraulic cylinder



# CALC/YALC/YJGL

杠杆式气压缸

CALC/YALC/YJGL PNEUMATIC LEVERAGE CLAMP



### 产品特性

此型式气压缸，采用标准规格化治具缸，加装杠杆式夹持机构，活塞推出为夹紧状态，主要机构零件安装于缸体外部，易于维护。缸体材质采用铝合金，内壁表面光滑，具耐磨性，使用寿命长，夹持机构材料均采用机械构造用碳素钢，坚固耐用。本系列各种型号均可安装磁性感应开关。

最大操作压力: 7kgf/cm<sup>2</sup>  
 最小操作压力: 3kgf/cm<sup>2</sup>  
 作动方式: 复动式

### 注意事项

夹紧及放松作动速度需适当放缓

### FEATURES

The series is a type of pneumatic cylinder that uses a standard lever-type clamping mechanism based on the principle of leverage. When the piston is pushed out, the pneumatic cylinder is in its clamped state. The main component parts are installed externally, which is optimal for product maintenance. The cylinder body is made with aluminum alloy for anti-abrasion, whereas the mechanical components are made with carbon steel to enhance durability and product lifespan. Options to include magnetic induction switches are available amongst various models, please contact us for more information.

Max. operating pressure: 7kgf/cm<sup>2</sup>  
 Min. operation pressure: 3kgf/cm<sup>2</sup>  
 Double acting

### NOTE

The speed of clamping and unclamping action needs to be slowed down appropriately.

剖面图 Sectional view

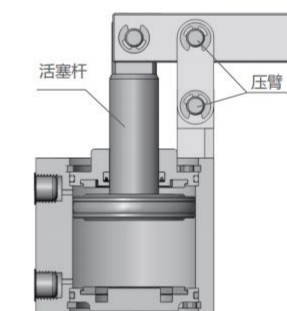

### 订购标示法 ORDERING INDICATION

示例: CALC-MS32F-S1

CALC	系列 Series	CALC/YALC/YJGL
MS	空白: Blank MS	标准型 Standard type (YALC仅标准型) 附磁石感应 With magnetic induction (YJGL仅附磁石感应型)
32	气缸内径 Cylinder inside diameter	Φ25, Φ32, Φ40, Φ50, Φ63, Φ80, Φ100
F	气路版式	仅CALC系列
S1	感应开关 Sensor switch	S1: 1个 S1: 1 pc of S1 S2: 2个 S2: 2 pcs of S2

Unit:mm

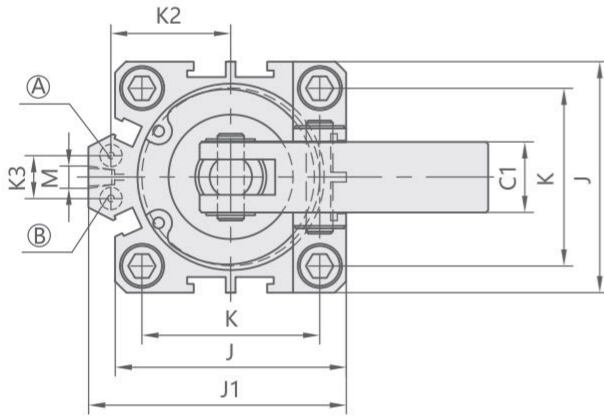
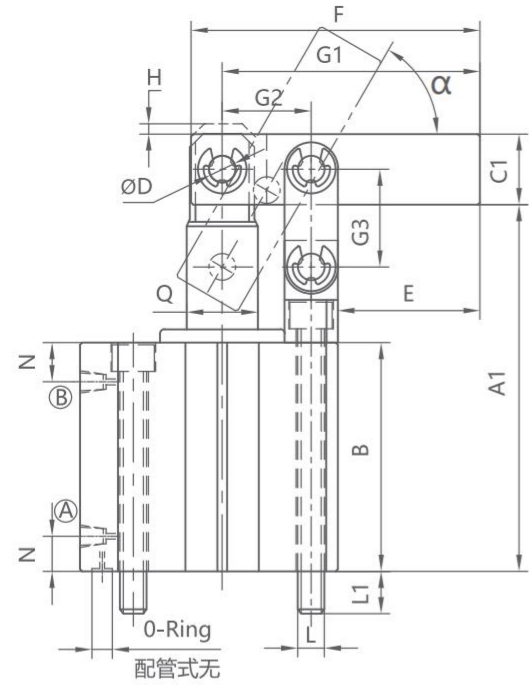

- Ⓐ 夹持气孔 Clamping port
- Ⓑ 放松气孔 Unclamping port

型号 Model	CALC-25	CALC-32	CALC-40	CALC-50	CALC-63	CALC-80	CALC-100	
标准型 Standard type	A1 65.5	78	82.5	96.6	115.5	138	163.5	
	B 41	49	51.5	58.6	72.5	84	99	
附磁石型 With magnet	A1 75.5	93	97.5	106.6	125.5	148	173.5	
	B 51	64	66.5	68.6	82.5	94	109	
C1	□13	□16	□16	□19	□22	□22	□25	
C2	6	8	8	10	10	10	12	
ΦD	Φ5	Φ6	Φ6	Φ8	Φ8	Φ10	Φ12	
E	25	31	32	35	38.5	47	53	
F	50	60	65	75	85	105	125	
G1	45	53	58	66	76	94	110	
G2	14	17	20	23	29.5	37	45	
G3	17	20	22	27	32	40	45	
H	3	3	3	3	3	3	3	
J	40	44	52	62	75	94	114	
J1	42	50	58	71	84.5	104	124	
K	28	34	40	48	60	74	90	
L	M5X0.8	M5X0.8	M6X1.0	M6X1.0	M6X1.0	M8	M10	
L1	10.5	11	9.5	11	11	15.5	15	
配管式 M	M5X0.8	PT1/8	PT1/8	PT1/4	PT1/4	PT1/4	PT1/4	
	N	8	9	10	11	14	18	
α	75°	70°	65°	70°	65°	65°	60°	
Q	Φ10	Φ12	Φ16	Φ20	Φ20	Φ25	Φ32	
气路版式	K2	-	23	27	33	40	49	59
	K3	-	7	7	13	13	14	14
	O环	-	S3	S3	P4	P4	P5	P5

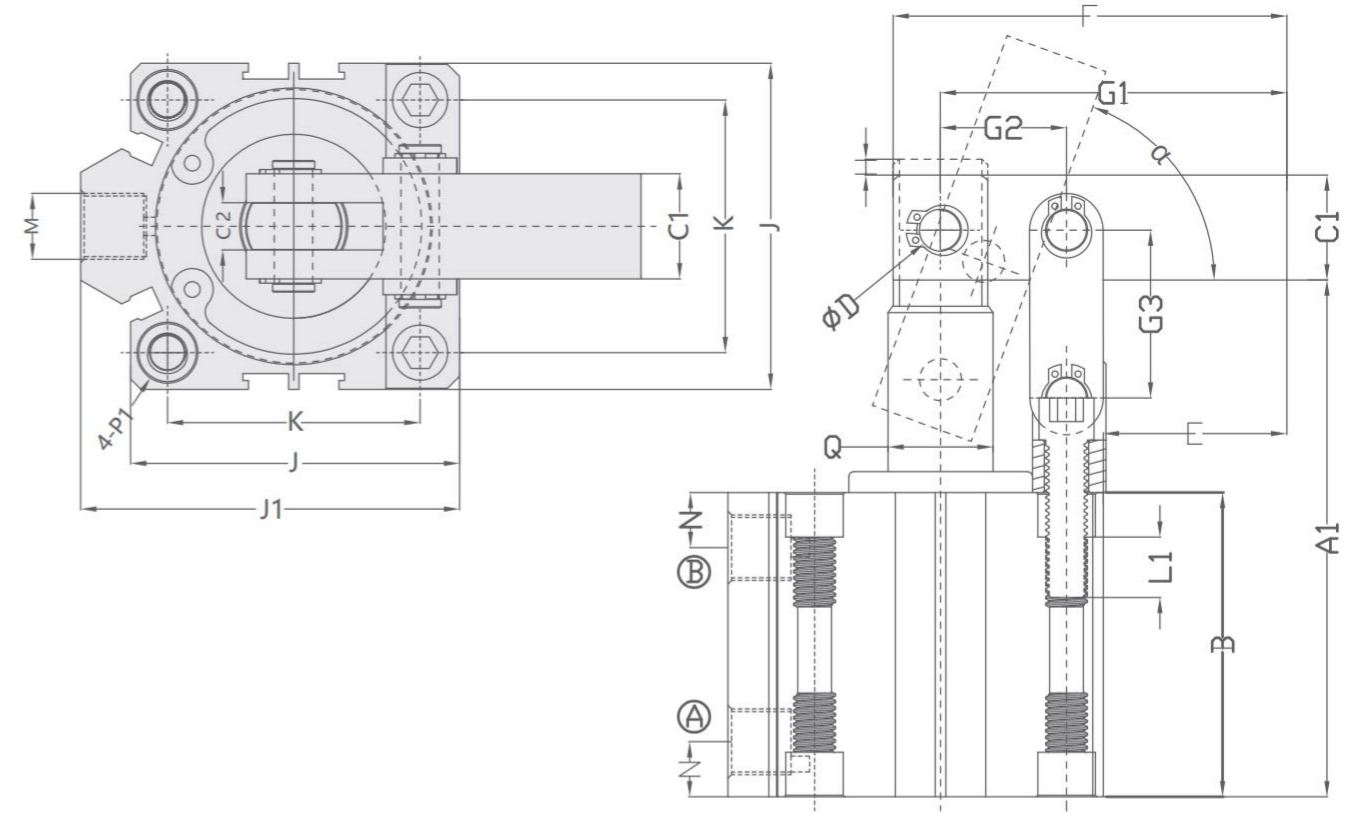

Unit:mm

型号 Model	YALC-25/ YJGL-25	YALC-32/ YJGL-32	YALC-40/ YJGL-40	YALC-50/ YJGL-50	YALC-63/ YJGL-63	YALC-80/ YJGL-80	YALC-100/ YJGL-100
YALC标准型 Standard type	A1	66	78.5	84	97.5	116	137
	B	41	49.5	51	58	72	81
YJGL附磁石型 With magnet	A1	76	83.5	94	107.5	126	147
	B	51	54.5	61	68	82	91
C1	□14	□16	□16	□20	□22	□22	□25
C2	6.1	8.1	8.1	10.1	10.1	10.1	12.2
ΦD	φ6	φ6	φ6	φ8	φ8	φ10	φ12
E	25	32	32	35	39	47	54
F	50	60	65	75	85	105	125
G1	45	53	58	66	76.5	94	111
G2	14	17	20	24	30	37	45
G3	15	20	22	31.5	36	40	47
H	3	3	3	3	3	3	3
J	40	44	52	62	75	94	114
J1	42	50	58	71	84.5	104	124
K	28	34	40	48	60	74	90
L1	8	8	9.5	11	11	15.5	15.5
M	M5x0.8	PT1/8	PT1/8	PT1/4	PT1/4	PT3/8	PT3/8
N	上9.5下5.5	9	9.5	10.5	12	14.5	上20.5下17
a	77°	70°	73°	73°	75°	65°	60°
Q	φ10	φ12	φ16	φ20	φ20	φ25	φ32
P1(不配 安装螺丝)	YALC-25/YJGL-25	双边沉孔φ8.2		深5.5	牙M6X1.0	通孔5.1	
	YALC-32/YJGL-32	双边沉孔φ8.2		深5.5	牙M6X1.0	通孔5.1	
	YALC-40/YJGL-40	双边沉孔φ10		深8.5	牙M8X1.25	通孔6.5	
	YALC-50/YJGL-50	双边沉孔φ11		深8.5	牙M8X1.25	通孔6.5	
	YALC-63/YJGL-63	双边沉孔φ11		深8.5	牙M8X1.25	通孔6.5	
	YALC-80/YJGL-80	双边沉孔φ14		深11	牙M12X1.75	通孔9.2	
	YALC-100/YJGL-100	双边沉孔φ17.6		深13	牙M14X2	通孔11.3	

规格参数表 SPECIFICATIONS

型号	理论夹持力 (7kgf/cm <sup>2</sup> )	夹紧行程	总行程	推出容积	拉入容积	推出受压面积	拉入受压面积	使用温度范围	使用流体
MODEL	CLAMPING FORCE AT 7kgf/cm <sup>2</sup> (kgf)	CLAMPING STROKE (mm)	TOTAL STROKE(mm)	EFF.PISTON CAPACITY CLAMP(cm <sup>3</sup> )	CYLINDER CAPACITY UNCLAMP(cm <sup>3</sup> )	EFF.PISTON AREA CLAMP(cm <sup>2</sup> )	EFF.PISTON AREA UNCLAMP(cm <sup>2</sup> )	RANGE OF TEMPERATURE(°C)	USABLE FLUID
CALC/YALC/YJGL-25	20	17	20	9.82	8.24	4.91	4.12	-10~+60°C	过滤之干燥 压缩空气 Filtered dry compressed air
CALC/YALC/YJGL-32	31	20	23	18.49	15.89	8.04	6.91	-10~+60°C	
CALC/YALC/YJGL-40	56	22	25	31.40	26.40	12.57	10.56	-10~+60°C	
CALC/YALC/YJGL-50	91	27	30	58.89	49.47	19.63	16.49	-10~+60°C	
CALC/YALC/YJGL-63	169	32	35	109.06	98.00	31.16	28	-10~+60°C	
CALC/YALC/YJGL-80	279	40	43	216.03	195.22	50.24	45.4	-10~+60°C	
CALC/YALC/YJGL-100	469	45	48	376.80	338.4	78.5	70.5	-10~+60°C	

# CPLCU

## 气压杠杆缸

### CPLCU PNEUMATIC LEVERAGE CLAMP



#### 产品特性

缸体的材质采用铝合金，活塞杆材质是45钢热处理，表面镀铬。  
本产品使用了的密封圈，可避免了气缸的泄漏，且其寿命长。  
应用了杠杆原理，使工件容易夹紧，提高效率。

最大操作压力：7kgf/cm<sup>2</sup>  
最小操作压力：3kgf/cm<sup>2</sup>  
作动方式：复动式

#### FEATURES

Body material: Aluminum alloy 6061T6 hard coat.  
Piston: S45C, Hard Chromed.  
Use high-quality seal to avoid leakage and keep long operation.  
Leverage structure design, the fixture can clamp easily, perform efficiently.

Max. operating pressure: 7kgf/cm<sup>2</sup>  
Min. operation pressure: 3kgf/cm<sup>2</sup>  
Double acting

#### 剖面图 Sectional view

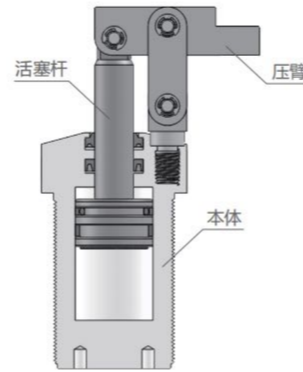

#### 注意事项

夹紧及放松作动速度需适当放缓。

#### NOTE

The speed of clamping and unclamping action needs to be slowed down appropriately.

#### 订购标示法 ORDERING INDICATION

##### 示例: CPLCU-40R-WF

CPLCU	系列 Series	CPLCU	
40	气缸内径 Cylinder inside diameter	Φ25, Φ32, Φ40, Φ50, Φ63	
R	压臂安装方式 Lever arm direction	标准型: 空白 L: 左 R: 右	Standard: Blank L: Left R: Right
W	W: 缸体上三方具有压臂安装座孔		
F	气路版式		

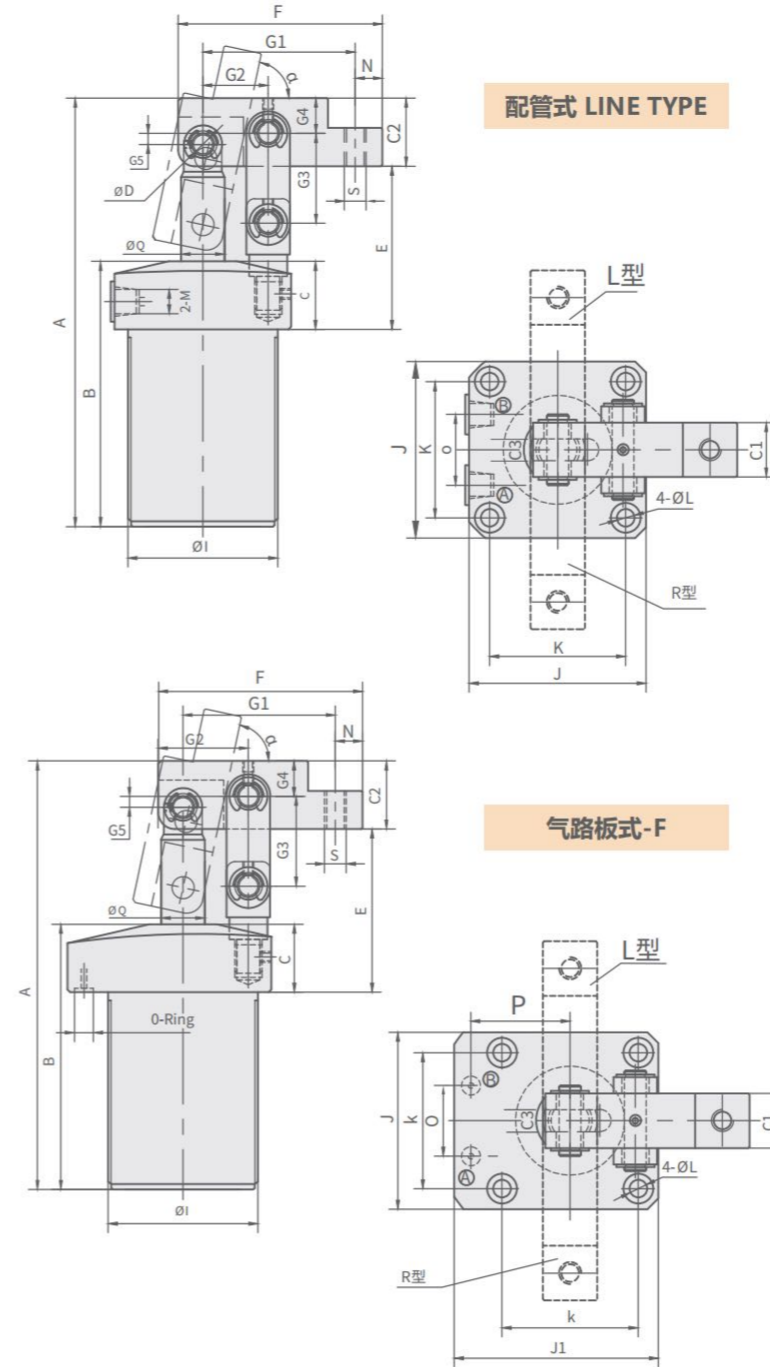

Unit:mm

型号 Model	CPLCU-25	CPLCU-32	CPLCU-40	CPLCU-50	CPLCU-63
A	128.5	149.5	157.5	174	179
B	86.5	97.5	97.5	104	105
C	25	25	25	25	25
C1	16	18	20	22	22
C2	17	20	25	30	30
C3	6	8	8	10	10
ΦD	Φ6	Φ6	Φ8	Φ10	Φ10
E	50	57	60	65	69
F	55	68	75	87.5	98
G1	41	52	56	63.5	74
G2	18	22	24	27.5	32
G3	26	33	33	44	48
G4	6.5	8	13	11	11
G5	4.5	5	4	10	10
H (行程余量)	2	4	3	3	3
ΦI	M40x1.5	M50x1.5	M55x1.5	M65x1.5	M80x1.5
J	50	60	65	75	90
K	37	45	50	58	70
L	Φ5.5- Φ9x5.5D	Φ6.5- Φ11x6.5D	Φ6.5- Φ11x6.5D	Φ8.5- Φ14x8.5D	Φ8.5- Φ14x8.5D
M	M5	PT1/8	PT1/8	PT1/8	PT1/8
N	7	8	10	14	14
O	23	23	26	32	35
Q	Φ14	Φ16	Φ16	Φ20	Φ20
S	M6	M8	M8	M12	M12
α	70°	75°	78°	70°	60°
气路板式 J1	60	70	75	88	108
P	26	30.5	33	38	48
O环	P3	P7	P7	P7	P7

- Ⓐ 夹持气孔 Clamping port
- Ⓑ 放松气孔 Unclamping port

#### 规格参数表 SPECIFICATIONS

型号	理论夹持力 (7kgf/cm <sup>2</sup> )	夹紧行程	总行程	推出容积	拉入容积	推出受压面积	拉入受压面积	使用温度范围	使用流体
MODEL	CLAMPING FORCE AT 7kgf/cm <sup>2</sup> (kgf)	CLAMPING STROKE (mm)	TOTAL STROKE(mm)	CYLINDER CAPACITY CLAMP(cm <sup>3</sup> )	CYLINDER CAPACITY UNCLAMP(cm <sup>3</sup> )	EFF.PISTON AREA CLAMP(cm <sup>2</sup> )	EFF.PISTON AREA UNCLAMP(cm <sup>2</sup> )	RANGE OF TEMPERATURE(°C)	USABLE FLUID
CPLCU-25	27	20	24	11.78	8.09	4.91	3.37	-10~+60°C	过滤之干燥 压缩空气 Filtered dry compressed air
CPLCU-32	42	28	32	25.73	19.30	8.04	6.03	-10~+60°C	
CPLCU-40	67	30	33	41.45	34.82	12.56	10.55	-10~+60°C	
CPLCU-50	107	30	33	64.78	54.42	19.63	16.49	-10~+60°C	
CPLCU-63	170	30	33	102.83	92.47	31.16	28.02	-10~+60°C	

# ASC

## 气压转角缸

### ASC PNEUMATIC SWING CLAMP



#### 产品特性

本产品适用于量产零件之专用机及MC治具，提高生产效率的帮手。主要功能为气压缸动作时，活塞下压行程中压板会旋转到设计的角度，再沿着直线继续下压直到压板夹紧工件。建议使用气压转角缸，请加装流量控制阀，避免速度过快，以及转角行程中，请勿夹持工件，导致损坏缸体及内部零件。缸体材质采用铝合金，表面硬膜处理，内壁表面光滑，使用寿命长。

最大操作压力：7 kgf/cm<sup>2</sup>  
 最小操作压力：4 kgf/cm<sup>2</sup>  
 动作方式：复动式

#### 注意事项

夹紧及放松动作速度需适当放缓。特殊压臂长度及重量不得超过标准压臂的1.5倍。压臂旋转示意图及安装拆卸方式，请参见第4页。

#### FEATURES

This machine with MC clamp is exclusively to mass produce spare parts. It is a big helper to raise production efficiency. The clamping arm of this clamp will swing around the angle when the piston traveling down, and then keep straight on until the clamping arm clamps the work-piece tightly. You had better install a flow control valve to adjust the acting speed, and don't clamp the workpiece when the clamp is running. Otherwise will be easy to damage the body and the spare parts. The material of the cylinder body is made of aluminum metal alloy the surface is processed with the hard membrane and the inside of it is smooth. It is long-lived to use.

Max. operating pressure: 7 kgf/cm<sup>2</sup>  
 Min. operation pressure: 4 kgf/cm<sup>2</sup>  
 Double acting

#### NOTE

The speed of clamping and unclamping action needs to be slowed down appropriately. The length and weight of the customized damping arm shall not exceed 1.5 times of the standard clamping arm. Please refer to Page 4 for installation instructions or removal methods of the clamping arm. Customization is available upon request, please contact us for more info.

#### 剖面图 Sectional view

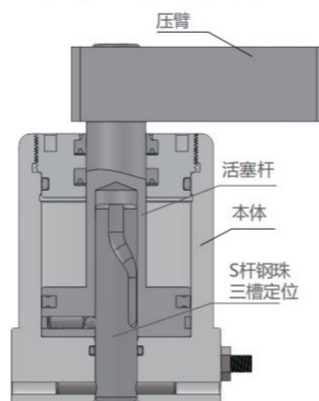

#### 订购标示法 ORDERING INDICATION

示例: ASC-MF32SR-90E

ASC	系列 Series	ASC
MF	类型 Type	空白: 配管式 Blank: Line type MS: 感应型 MS: Magnetic type MF: 深孔型附调速 FA: 法兰型 FA: Flange type TB: 全牙型 TB: Threaded body
32	气缸内径 Cylinder inside diameter	Φ25, Φ32, Φ40, Φ50, Φ63
S	压板型式 Clamping arm type	S: 单边压板 D: 双边压板 S: Single side arm D: Double side arm
R	转角方向 Rotating direction	R: 顺时针右转 L: 逆时针左转 N: 0°不旋转 R: Turn right L: Turn left N: 0°No swing
90	转角角度 Rotating angle	标准角度 Standard angle 90° (±2°) 订做角度 Order angle 0°, 45° (±2°), 60° (±2°)
E	行程加长 Stroke extension	(具体行程加长型号详见后面尺寸表)

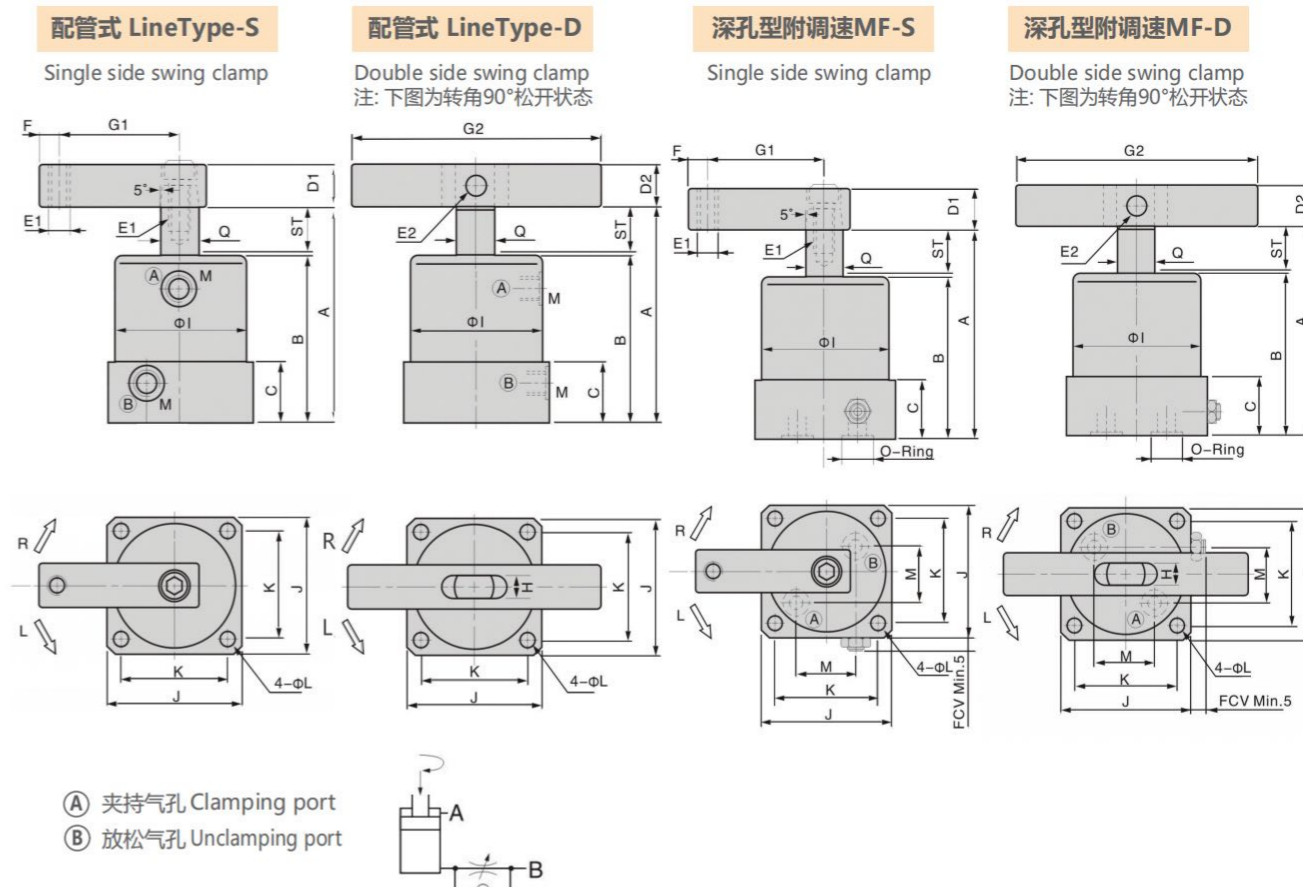

MODEL	ST:Swing A /Clamping Unclamp	B	C	D1	D2	E1	E2	F	G1	G2	H	ΦI	J	K	L	M	O-RING	Q	
ASC-25	22:9/13	89	65	23	□16	-	M6×1.0	-	6	35	-	Φ35	38	30	Φ4.6	M5×0.8	-	Φ14	
ASC-32	26:11/15 41:11/30	108 138	78 93	28	□19	□19	M8×1.25	Φ8	8	50	140	9	Φ46	50	40	Φ5.6	PT1/8	-	Φ16
ASC-40	26:11/15 41:11/30	108 138	78 93	28	□19	□19	M8×1.25	Φ8	8	55	140	9	Φ55	60	48	Φ6.8	PT1/8	-	Φ16
ASC-50	30:13/17 47:13/34	124 158	90 107	31	□25	□22	M10×1.5	Φ8	10	60	160	10	Φ65	70	57	Φ6.8	PT1/8	-	Φ20
ASC-63	30:13/17 47:13/34	124 158	90 107	31	□25	□22	M10×1.5	Φ8	10	70	160	10	Φ78	83	67	Φ9	PT1/8	-	Φ20
ASC-MF32	26:11/15	108	78	22	□19	□19	M8×1.25	Φ8	8	50	140	9	Φ46	50	40	Φ5.6	19	P7	Φ16
ASC-MF40	26:11/15	108	78	22	□19	□19	M8×1.25	Φ8	8	55	140	9	Φ55	60	48	Φ6.8	23	P7	Φ16
ASC-MF50	30:13/17	124	90	25	□25	□22	M10×1.5	Φ8	10	60	160	10	Φ65	70	57	Φ6.8	28	P9	Φ20
ASC-MF63	30:13/17	124	90	25	□25	□22	M10×1.5	Φ8	10	70	160	10	Φ78	83	67	Φ9	32	P9	Φ20

#### 规格参数表 SPECIFICATIONS

型号	理论夹持力 (7kgf/cm <sup>2</sup> )	转角行程	夹紧行程	总行程	推出容积	拉入容积	推出受压面积	拉入受压面积	使用温度范围	使用流体
MODEL	CLAMPING FORCE AT 7kgf/cm <sup>2</sup> (kgf)	SWING STROKE(mm)	CLAMPING STROKE (mm)	TOTAL STROKE(mm)	CYLINDER CAPACITY UNCLAMP(cm <sup>3</sup> )	CYLINDER CAPACITY CLAMP(cm <sup>3</sup> )	EFF.PISTON AREA UNCLAMP(cm <sup>2</sup> )	EFF.PISTON AREA CLAMP(cm <sup>2</sup> )	RANGE OF TEMPERATURE(°C)	USABLE FLUID
ASC-25	24	9	13	22	12.28	7.41	4.91	3.37	-10~+60°C	过滤之干燥 压缩空气 Filtered dry compressed air
ASC-32	42	11	15/30	26/41	20.9/32.96	15.68/24.73	8.04	6.03	-10~+60°C	
ASC-40	74	11	15/30	26/41	32.66/51.5	27.43/43.26	12.56	10.55	-10~+60°C	
ASC-50	115	13	17/34	30/47	58.89/92.26	49.47/77.5	19.63	16.49	-10~+60°C	
ASC-63	196	13	17/34	30/47	93.48/146.45	84.06/131.69	31.16	28.02	-10~+60°C	

### 感应式 MS25S

Single side swing clamp

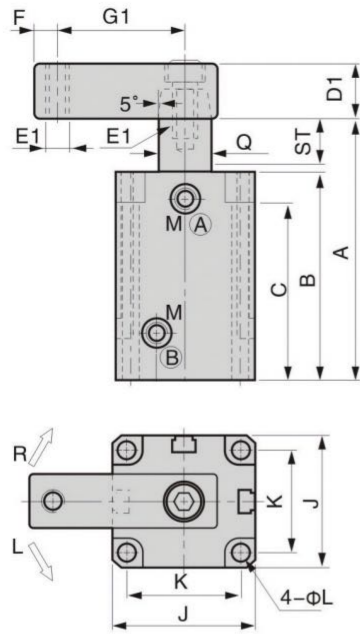

### 感应式 MS32S-63S

Single side swing clamp

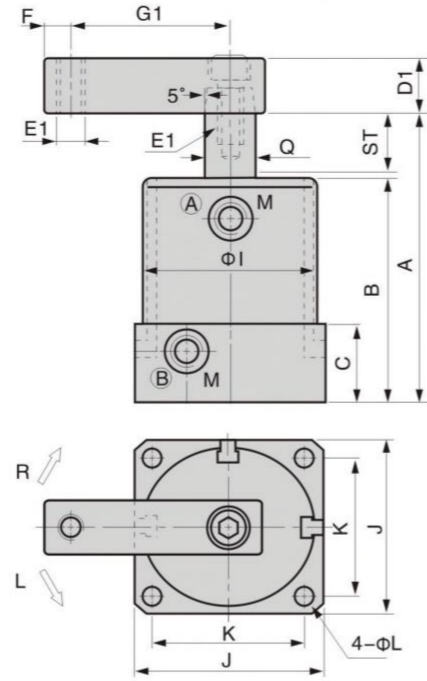

### 感应式 MS32D-63D

Double side swing clamp  
注: 下图为转角90°松开状态

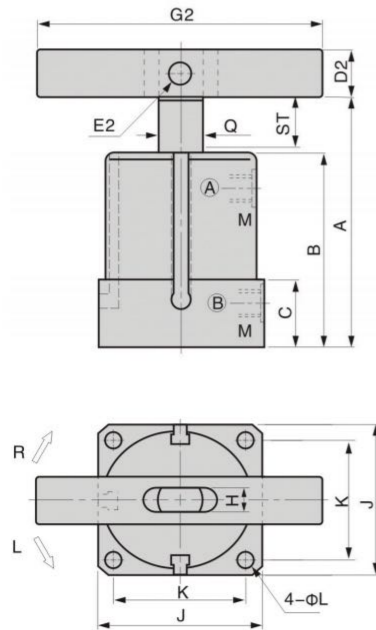

### 法兰型FA-S

Single side swing clamp

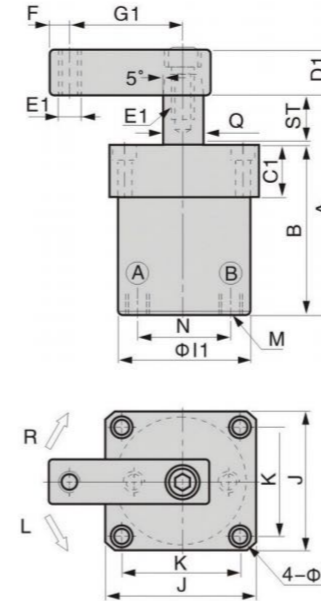

### 全牙型TB-S

Single side swing clamp

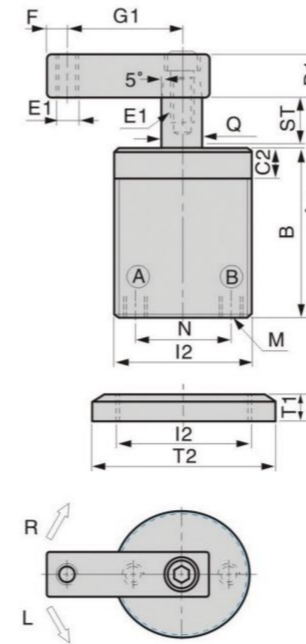

- Ⓐ 夹持气孔 Clamping port
- Ⓑ 放松气孔 Unclamping port

### 法兰型FA-D

Double side swing clamp  
注: 下图为转角90°松开状态

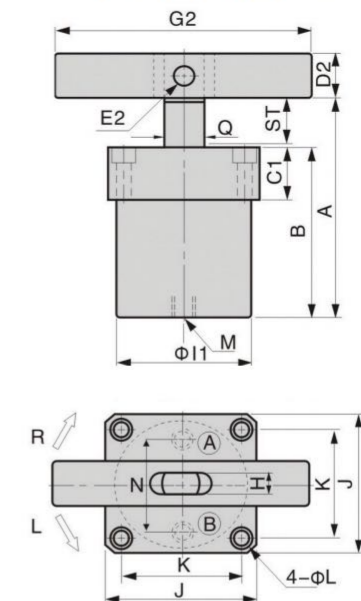

### 全牙型TB-D

Double side swing clamp  
注: 下图为转角90°松开状态

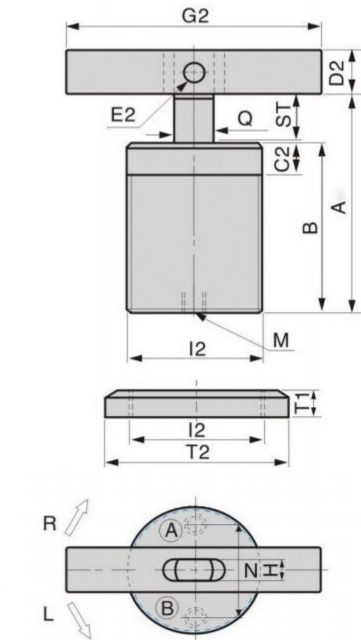

Unit:mm

MODEL	ST:Swing A /Clamping	松开状态 Unclamp	B	C	D1	D2	E1	E2	F	G1	G2	H	ΦI	J	K	L	M	Q
ASC-MS25	22:9/13	94	70	60	□16	-	M6×1.0	-	6	35	-	-	Φ35	38	30	Φ4.6	M5×0.8	Φ14
ASC-MS32	26:11/15	113	83	28	□19	□19	M8×1.25	Φ8	8	50	140	9	Φ46	50	40	Φ5.6	PT1/8	Φ16
ASC-MS40	26:11/15	113	83	28	□19	□19	M8×1.25	Φ8	8	55	140	9	Φ55	60	48	Φ6.8	PT1/8	Φ16
ASC-MS50	30:13/17	129	95	31	□25	□22	M10×1.5	Φ8	10	60	160	10	Φ65	70	57	Φ6.8	PT1/8	Φ20
ASC-MS63	30:13/17	129	95	31	□25	□22	M10×1.5	Φ8	10	70	160	10	Φ78	83	67	Φ9	PT1/8	Φ20

Unit:mm

MODEL	ST:Swing A /Clamping	松开状态 Unclamp	B	C1	C2	D1	D2	E1	E2	F	G1	G2	H	ΦI1	I2	J	K	L	M	N	T1× 2PCS	T2	Q
ASC-FA32 ASC-TB32	26:11/15	108	78	22	12	□19	□19	M8×1.25	Φ8	8	50	140	9	Φ46	M50×1.5	50	40	Φ5.6-Φ9×5.5D	PT1/8	32	11	Φ70	Φ16
ASC-FA40 ASC-TB40	26:11/15	108	78	22	12	□19	□19	M8×1.25	Φ8	8	55	140	9	Φ55	M55×1.5	60	48	Φ6.8-Φ10.5×6.5D	PT1/8	40	11	Φ75	Φ16
ASC-FA50 ASC-TB50	30:13/17	124	90	25	15	□25	□22	M10×1.5	Φ8	10	60	160	10	Φ65	M65×1.5	70	57	Φ6.8-Φ10.5×6.5D	PT1/8	50	12	Φ85	Φ20
ASC-FA63	30:13/17	124	90	25	-	□25	□22	M10×1.5	Φ8	10	70	160	10	Φ78	-	83	67	Φ9-Φ14×9D	PT1/8	63	-	-	Φ20

# NAU

## 上法兰气路板型气压转角缸

## NAU PNEUMATIC SWING CLAMP



### 产品特性

缸体的材料是铝合金，表面进行了发黑处理，表面热处理增加其耐磨性。压紧的方法有单臂和双臂两种。

最大操作压力：7 kgf/cm<sup>2</sup>  
 最小操作压力：4 kgf/cm<sup>2</sup>  
 作动方式：复动式

### FEATURES

Aluminum alloy body Blackening, Surface heat-treatment for product good wear-resisting. The type of clamping includes single side swing clamp and double side swing clamp.

Max. operating pressure: 7 kgf/cm<sup>2</sup>  
 Min. operation pressure: 4 kgf/cm<sup>2</sup>  
 Double acting

### 注意事项

夹紧及放松作动速度需适当放缓。特殊压臂长度及重量不得超过标准压臂的1.5倍。压臂旋转示意图及安装拆卸方式，请参见第4页。

### NOTE

The speed of clamping and unclamping action needs to be slowed down appropriately. The length and weight of the customized clamping arm shall not exceed 1.5 times of the standard clamping arm. Please refer to Page 4 for installation instructions or removal methods of the clamping arm.

### 订购标示法 ORDERING INDICATION

#### 示例：NAUL-40-90

<b>NAU</b>	系列 Series	NAU/NAUD
<b>L</b>	转角方向 Rotating direction	右转R或左转L Turn right R or turn left L
<b>40</b>	气缸内径 Cylinder inside diameter	Φ32, Φ40, Φ50, Φ63
<b>90</b>	转角角度 Rotating angle	标准角度 Standard angle 90°(±2°) 订做角度 Order angle 0°,45°(±2°),60°(±2°)

### NAU

Single side swing clamp

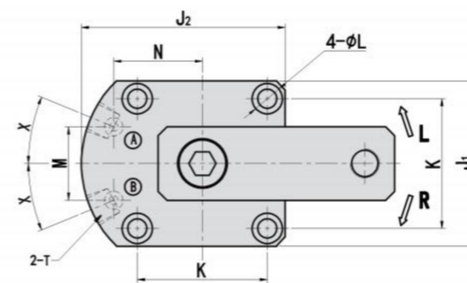
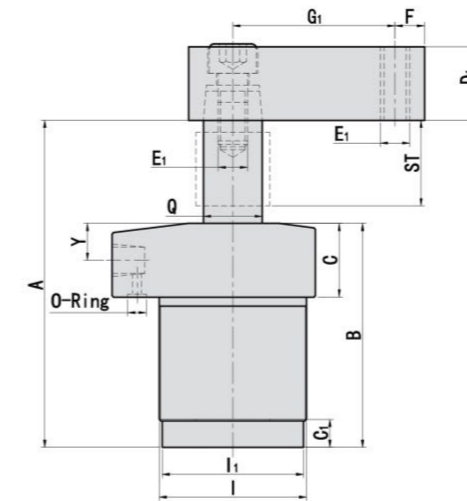

### NAUD

Double side swing clamp  
 注：下图为转角90°松开状态

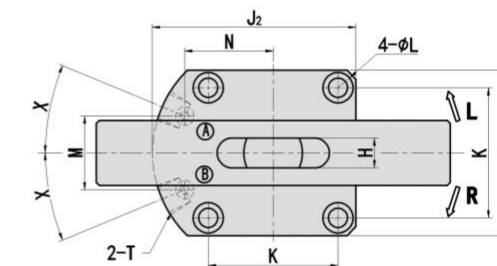
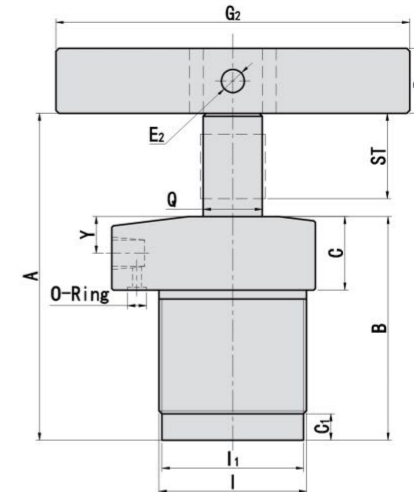

- (A) 夹持气孔 Clamping port
- (B) 放松气孔 Unclamping port

型号	理论夹持力 (7kgf/cm <sup>2</sup> )	转角行程	夹紧行程	总行程	拉入容积	推出容积	拉入受压面积	推出受压面积	使用温度范围
MODEL	CLAMPING FORCE AT 7kgf/cm <sup>2</sup> (kgf)	SWING STROKE(mm)	CLAMPING STROKE (mm)	TOTAL STROKE(mm)	CYLINDER CAPACITY CLAMP(cm <sup>3</sup> )	CYLINDER CAPACITY UNCLAMP(cm <sup>3</sup> )	EFF.PISTON AREA CLAMP(cm <sup>2</sup> )	EFF.PISTON AREA UNCLAMP(cm <sup>2</sup> )	RANGE OF TEMPERATURE(°C)
NAU-32	34	14	15	29	14.21	23.32	4.9	8.04	-10~+60°C
NAU-40	66	14	15	29	27.32	36.42	9.42	12.56	-10~+60°C
NAU-50	115	14	15	29	47.82	56.93	16.49	19.63	-10~+60°C
NAU-63	184	14	15	29	76.13	90.36	26.25	31.16	-10~+60°C

Unit:mm

MODEL	ST:Swing /Clamping	A:松开状态 Unclamp	B	C	C1	D1	D2	E1	E2	F	G1	G2	H	I	I1	J1	J2	K	L	M	N	T	X	Y	Q	O-Ring
NAU-32 NAUD-32	29:14/15	111	76	25	9	25	22	M10	Φ8	10	55	120	10	M50×1.5	Φ48	56	69	44	Φ6.5-Φ10.5×6.5D	24.9	30	PT1/8	22.5°	12.5	Φ20	P5
NAU-40 NAUD-40	29:14/15	113.6	80	27	9	25	22	M10	Φ8	10	55	120	10	M55×1.5	Φ53	62	71.5	48	Φ6.5-Φ10.5×6.5D	26	31.4	PT1/8	22.5°	14	Φ20	P5
NAU-50 NAUD-50	29:14/15	114.5	80	27	9	25	22	M10	Φ8	10	55	120	10	M65×1.5	Φ63	74	87	57	Φ8.5-Φ14×9D	27.4	37.6	PT1/8	20°	14	Φ20	P7
NAU-63 NAUD-63	29:14/15	118	85	32	9	32	25	M12	Φ10	11	75	140	12	M80×1.5	Φ77	88	105.5	70	Φ11-Φ16.5×11D	38	46	PT1/8	22.5°	19	Φ25	P7

# PB

## 感应式气压转角缸

### PB PNEUMATIC SWING CLAMP



#### 产品特性

设计简单，结构紧凑，重量轻，寿命长以及高的夹持力使它成为一种好的夹具。本产品有长行程及短行程两种可任意选择上面和下面安装。广泛应用于工业自动化，例如：薄片金属的夹持、输送带上工件的夹紧输送，以及包装流水线作业。

最大操作压力：7 kgf/cm<sup>2</sup>  
 最小操作压力：4 kgf/cm<sup>2</sup>  
 作动方式：复动式

#### 注意事项

夹紧及放松作动速度需适当放缓。特殊压臂长度及重量不得超过标准压臂的1.5倍。压臂旋转示意图及安装拆卸方式，请参见第4页。

#### 订购标示法 ORDERING INDICATION

示例：PBS-40R-90-S2

PB	系列 Series	PB
S	行程 Stroke	长行程L: Long stroke 短行程S: Short stroke
40	气缸内径 Cylinder inside diameter	Φ25, Φ32, Φ40, Φ50
R	转角方向 Rotating direction	右转R或左转L Turn right or turn left
90	转角角度 Rotating angle	标准角度 Standard angle 90° (±2°) 订做角度 Order angle 0°, 45° (±2°), 60° (±2°)
S2	感应开关 Sensor switch	S1: 1个 S1: 1 pc of S1 S2: 2个 S2: 2 pcs of S2

#### FEATURES

Simple and compact structure, lightweight, high clamping capacity, and long product lifespan. This series has the option of choosing a long or a short stroke, which can be installed at the top or the bottom. It is widely used in industrial automation, such as clamping of sheet metal, clamping of workpieces on conveyor belts, and packaging assembly line operations.

Max. operating pressure: 7 kgf/cm<sup>2</sup>  
 Min. operation pressure: 4 kgf/cm<sup>2</sup>  
 Double acting

剖面图 Sectional view

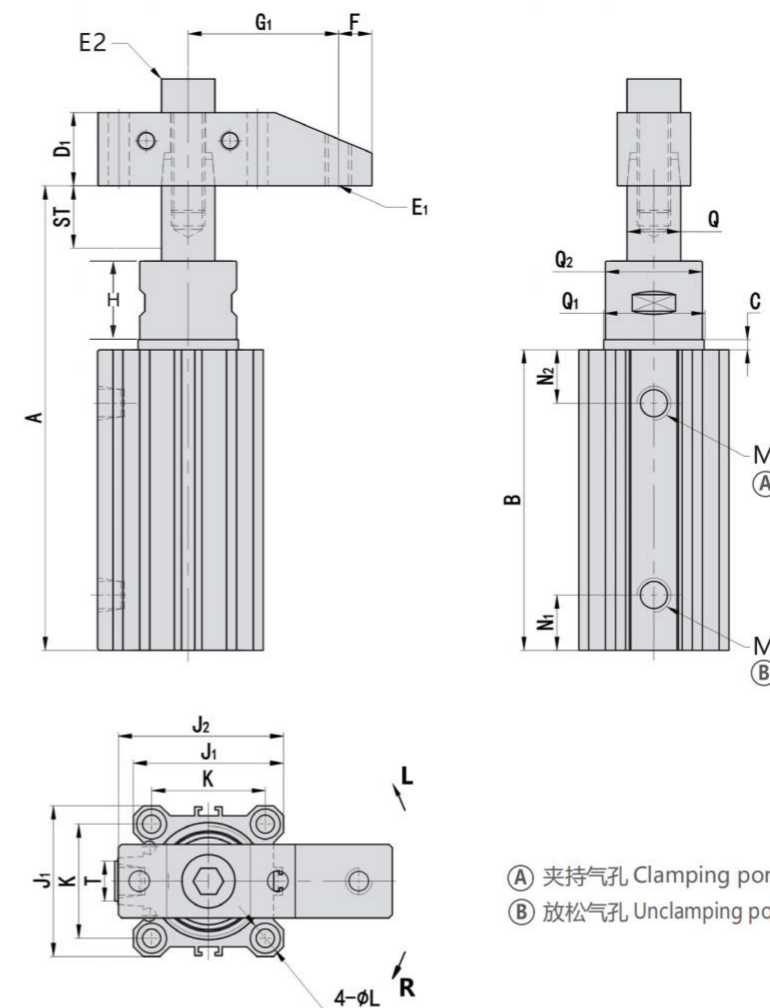
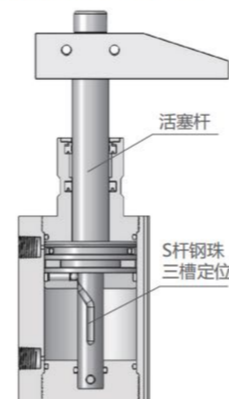

Ⓐ 夹持气孔 Clamping port  
 Ⓑ 放松气孔 Unclamping port

#### 规格参数表 SPECIFICATIONS

型号 MODEL	理论夹持力 (7kgf/cm <sup>2</sup> ) CLAMPING FORCE AT 7kgf/cm <sup>2</sup> (kgf)	转角行程 SWING STROKE(mm)	夹紧行程 CLAMPING STROKE (mm)	总行程 TOTAL STROKE(mm)	拉入容积 CYLINDER CAPACITY CLAMP(cm <sup>3</sup> )	推出容积 CYLINDER CAPACITY UNCLAMP(cm <sup>3</sup> )	拉入受压面积 EFF.PISTON AREA CLAMP(cm <sup>2</sup> )	推出受压面积 EFF.PISTON AREA UNCLAMP(cm <sup>2</sup> )	使用温度范围 RANGE OF TEMPERATURE(°C)	使用流体 USABLE FLUID
PBS-25	24	9.5	10	19.5	6.57	9.57	3.37	4.91	-10~+60°C	过滤之干燥压缩空气 Filtered dry compressed air
PBL-25	24	9.5	20	29.5	9.94	14.48	3.37	4.91	-10~+60°C	
PBS-32	42	15	10	25	15.05	20.10	6.02	8.04	-10~+60°C	
PBL-32	42	15	20	35	21.07	28.14	6.02	8.04	-10~+60°C	
PBS-40	74	15	10	25	26.40	31.40	10.56	12.56	-10~+60°C	
PBL-40	74	15	20	35	36.96	43.96	10.56	12.56	-10~+60°C	
PBS-50	116	19	20	39	64.35	76.56	16.5	19.63	-10~+60°C	
PBL-50	116	19	50	69	113.85	135.45	16.5	19.63	-10~+60°C	

Unit:mm

MODEL	ST:Swing /Clamping	A:松开状态 /Unclamp	B	C	D1	E1	E2	F	G1	H	J1	J2	K	L	M	N1	N2	Q	Q1	Q2	T
PBS-25	19.5:9.5/10	109	73	3	□16	M6	M8	7	32	9	40	42	28	Φ5.5-Φ9×9D	M5	16.5	14	Φ14	Φ26	Φ25	11
PBL-25	29.5:9.5/20	129	83	3	□22	M8	M10	10	45	23.5	45	49.5	34	Φ5.5-Φ9×9D	PT1/8	16.5	16	Φ16	Φ30	Φ29	14.8
PBS-40	25:15/10	134.5	80	3	□22	M8	M10	10	45	24.5	52	57	40	Φ5.5-Φ9×12D	PT1/8	19	16	Φ16	Φ30	Φ29	14.8
PBL-40	35:15/20	154.5	90	3.5	□25	M10	M12	10	65	39	64	71	50	Φ6.6-Φ11×13D	PT1/4	24	17	Φ20	Φ37	Φ36	20

# PSB

## 气压块状转角缸

## PSB PNEUMATIC SWING CLAMP

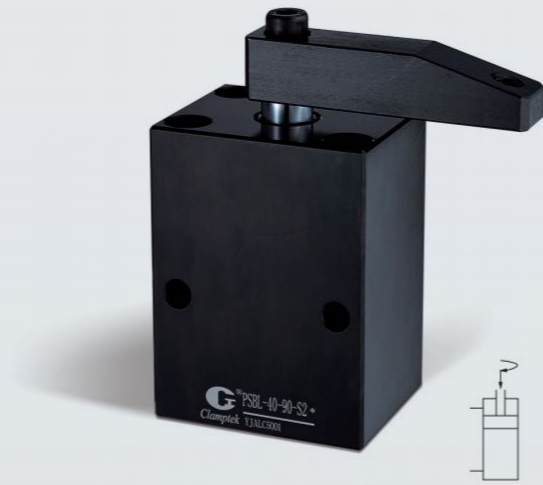

### 产品特性

设计简单，结构紧凑，重量轻，寿命长以及高的夹持力使它成为一种好的夹具。本产品有可加装感应器，可任意选择上面和下面及侧面安装。

最大操作压力: 7 kgf/cm<sup>2</sup>  
 最小操作压力: 4 kgf/cm<sup>2</sup>  
 作动方式: 复动式

### FEATURES

Simple and compact structure, lightweight, high clamping capacity, and long product lifespan. This product can be equipped with sensor switches with the option to install on the top, bottom or on the side.

Max. operating pressure: 7 kgf/cm<sup>2</sup>  
 Min. operation pressure: 4 kgf/cm<sup>2</sup>  
 Double acting

剖面图 Sectional view

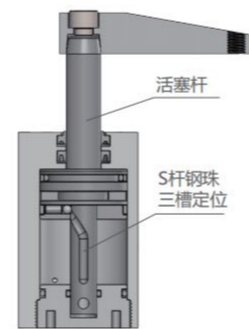

### 注意事项

夹紧及放松作动速度需适当放缓。特殊压臂长度及重量不得超过标准压臂的1.5倍。压臂旋转示意图及安装拆卸方式，请参见第4页。

### NOTE

The speed of clamping and unclamping action needs to be slowed down appropriately. The length and weight of the customized clamping arm shall not exceed 1.5 times of the standard clamping arm. Please refer to page 4 for the rotation diagram, installation instruction and removal methods of the clamping arm.

### 订购标示法 ORDERING INDICATION

示例: PSBL-40-90-S1

PSB	系列 Series	PSB
L	转角方向 Rotating direction	右转R或左转L Turn right or turn left
40	气缸内径 Cylinder inside diameter	Φ25, Φ32, Φ40, Φ50, Φ63
90	转角角度 Rotating angle	标准角度 Standard angle 90° (±2°) 订做角度 Order angle 0°, 45° (±2°), 60° (±2°)
S1	感应开关 Sensor switch	S1: 1个 S1:1 pc of S1 S2: 2个 S2:2 pcs of S2

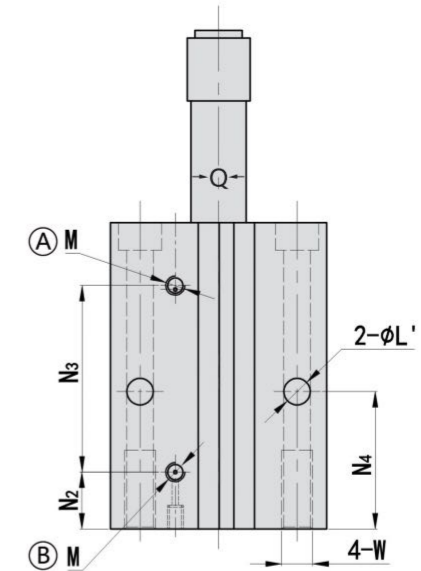
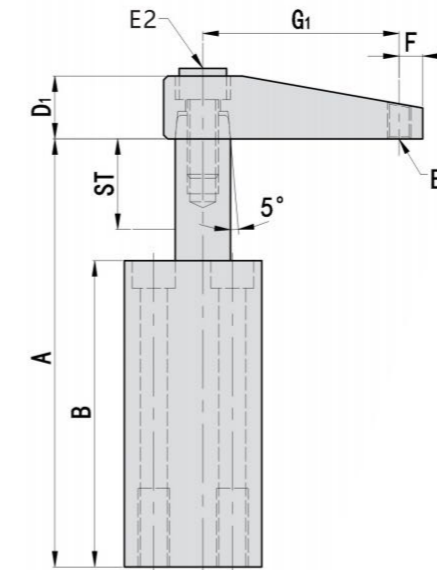

Ⓐ 夹持气孔 Clamping port  
 Ⓑ 放松气孔 Unclamping port

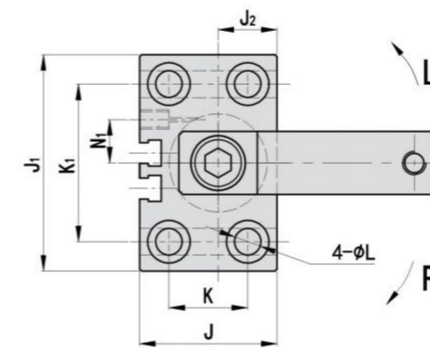

### 规格参数表 SPECIFICATIONS

型号	理论夹持力 (7kgf/cm <sup>2</sup> )	转角行程	夹紧行程	总行程	拉入容积	推出容积	拉入受压面积	推出受压面积	使用温度范围	使用流体
MODEL	CLAMPING FORCE AT 7kgf/cm <sup>2</sup> (kgf)	SWING STROKE(mm)	CLAMPING STROKE (mm)	TOTAL STROKE(mm)	CYLINDER CAPACITY CLAMP(cm <sup>3</sup> )	CYLINDER CAPACITY UNCLAMP(cm <sup>3</sup> )	EFF.PISTON AREA CLAMP(cm <sup>2</sup> )	EFF.PISTON AREA UNCLAMP(cm <sup>2</sup> )	RANGE OF TEMPERATURE(°C)	USABLE FLUID
PSB-25	24	13	14	27	9.10	13.26	3.37	4.91	-10~+60°C	过滤之干燥 压缩空气 Filtered dry compressed air
PSB-32	42	16	14	30	18.06	24.12	6.02	8.04	-10~+60°C	
PSB-40	74	15	15	30	31.68	37.68	10.56	12.56	-10~+60°C	
PSB-50	116	17	15	32	52.80	62.82	16.5	19.63	-10~+60°C	
PSB-63	196	15	15	30	84.06	93.48	28.02	31.16	-10~+60°C	

Unit:mm

MODEL	ST:Swing /Clamping	A:松开状态 Unclamp	B	D1	E1	E2	F	G1	J	J1	J2	K	K1	N1	N2	N3	N4	L	L'	M	W	Q
PSB-25	27:13/14	109	78	□16	M6	M8	6	50	35	55	15	20	40	11	14.5	47.5	35	Φ6.8- Φ11×7D	Φ6.8	M5	M8×20D	Φ14
PSB-32	30:16/14	126	90	□19	M8	M8	9	60	45	60	20	30	45	12	21	51.5	45	Φ6.8- Φ11×7D	Φ6.8	PT1/8	M8×25D	Φ16
PSB-40	30:15/15	126	90	□19	M8	M8	9	70	55	70	25	37	52	15	22	49	40	Φ8.5- Φ14×9D	Φ8.5	PT1/8	M10×20D	Φ16
PSB-50	32:17/15	137	100	□25	M12	M10	10	80	65	85	30	46	66	17.5	25	53.5	40	Φ8.5- Φ14×9D	Φ8.5	PT1/8	M10×30D	Φ20
PSB-63	30:15/15	137	100	□25	M12	M10	10	90	80	100	37.5	60	80	18	20.5	56.5	35	Φ10.5- Φ16.5×10.5D	Φ10.5	PT1/8	M12×25D	Φ20

# CSW

## 气压支撑缸

### CSW PNEUMATIC SUPPORT CLAMP



#### 产品特性

##### 气压上升型:

活塞杆初始状态为下降, 供给气压使活塞杆上升并接触供件任意位置后停止, 在停止的同时气压作用于夹套的夹紧力施加于活塞杆, 使活塞杆得以稳固的支撑工件。

##### 弹簧上升型:

活塞杆初始状态为上升, 将工件放置于活塞杆上因工件的重量而下降到特定距离, 此时供给气压作用于夹套的夹紧力施加于活塞杆, 使活塞杆得以稳固的支撑工件。

#### FEATURES

##### Air pressure rising type:



The initial state of the piston rod is falling. The supply air pressure makes the piston rod rise and stop after getting into contact with any position of the supply part. At the same time, the clamping force acting on the clamp cover by air pressure is applied to the piston rod, so that the piston rod can firmly support the workpiece.

##### Spring rising type:

The initial state of the piston rod is rising, and the workpiece is placed on the piston rod and lowered to a certain distance due to the weight of the workpiece. At this time, the clamping force acting on the clamp cover by supply air pressure is applied to the piston rod, so that the piston rod can firmly support the workpiece.

#### 订购标示法 ORDERING INDICATION

##### 示例: CSW-30BLPL

CSW	系列 Series	CSW				
30	气缸外径 Cylinder external diameter	M26×1.5 M36×1.5 M30×1.5 M45×1.5				
B	型式 type	A: 弹簧上升型 B: 气压上升型(标准)	A: Spring rising type B: Pneumatic rising type(standard)		  弹簧上升型 气压上升型	
L	压强 Pressure	低压 1MPa	Low Pressure 1 MPa			
P	版本 Version					
L	弹簧力	无记号: 标准型 L:弱弹簧型	No mark: Standard L:Low spring			

#### 规格参数表 SPECIFICATIONS

型号 MODEL	支撑力 CLAMPING FORCE		气缸容量(cm³) CYLINDER CAPACITY (cm³)	上升弹簧力(Kgf) RISING SPRING		行程 STROKE (mm)	使用压力 范围 RANGE OF WORK PRESSURE(MPa)	帽盖最大允许重量 MAX. ALLOWABLE MASS OF CAP		重量 WEIGHT(Kg)
	气压为1MPa时 AT 1MPa(kgf)	气压为0.5MPa时 AT 0.5MPa(kgf)		标准型 STANDARD TYPE (kgf)	弱弹簧型 LOW SPRING TYPE(kgf)			标准型 STANDARD TYPE (kgf)	弱弹簧型 LOW SPRING TYPE(kgf)	
CSW-26	80	30	0.8	0.6~0.8	0.1~0.3	6.5	0.4~1MPa	0.05	0.025	0.2
CSW-30	130	50	1.3	0.6~0.8	0.2~0.4	6.5				0.3
CSW-36	190	70	2.2	0.6~0.8	0.2~0.4	8.0				0.4
CSW-45	350	130	3.6	0.8~1.1	0.2~0.4	8.0				0.8

#### 气压与工件支撑力的关系

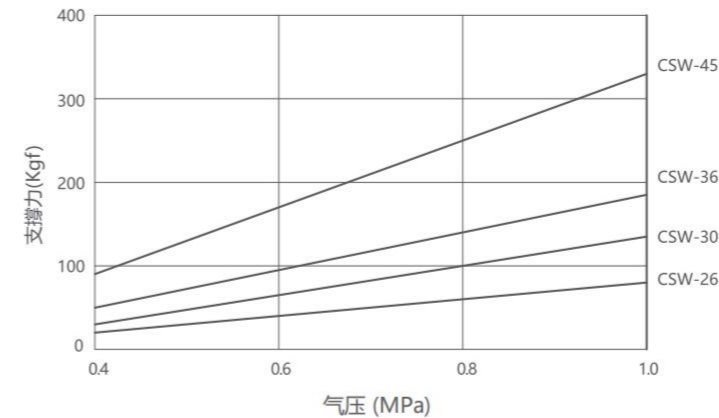

本图表示静态负荷条件下的支撑力

#### 负荷与变位量的关系

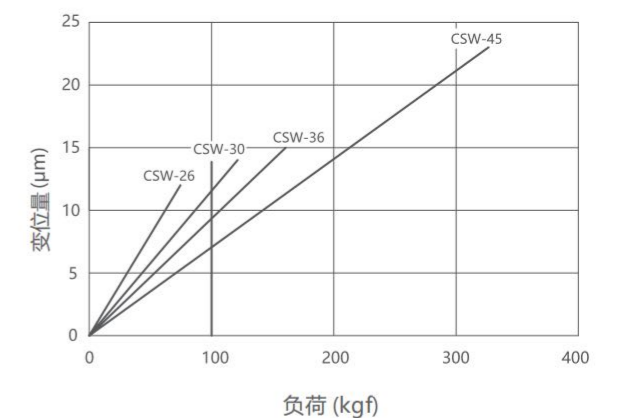

本图表示在气压 1MPa 条件下的静态负荷下的变化

#### CSW-AL

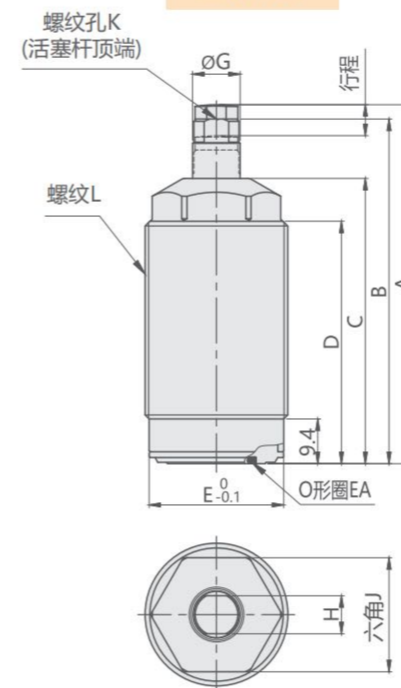

#### CSW-BL

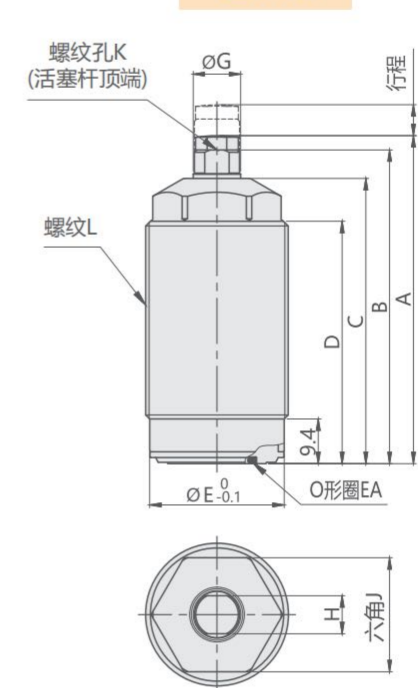

#### 气压回路图

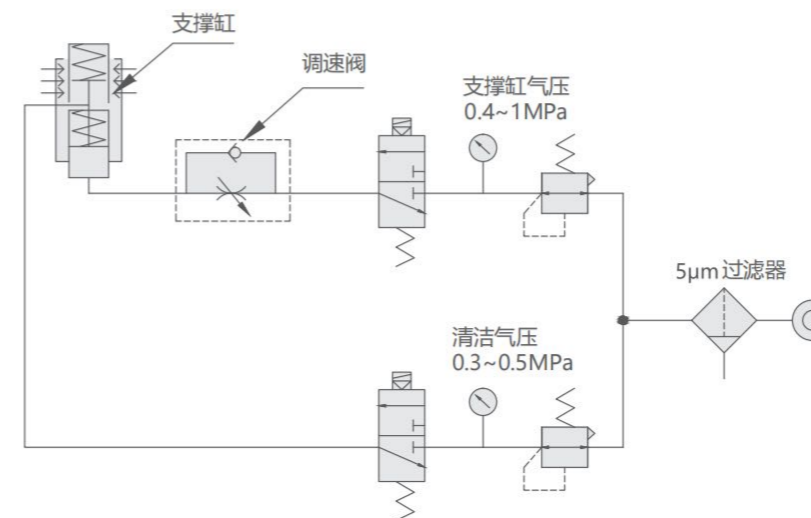

#### 注意事项

1. 请通过调速阀来调整支撑杆的上升动作度, 使其上升动作时间在0.5秒以上。
2. 请避免以下使用方法。否则会导致支撑缸动作不顺及支撑力下降。
  - ×向支撑杆施加偏心负荷
  - ×施加超过额定支撑力的负荷
  - ×锁定时转动支撑杆
3. 请使通气孔与大气连通, 且必须阻止切液、切屑等异物进入。否则会导致支撑缸损坏。
4. 请仅在换夹工件时进行空气清洁。空气清洁时, 支撑杆会有上升。
5. 与压紧缸对置使用时, 支撑力需要满足压紧缸压紧力+切削负荷的1.5倍以上。

帽盖详图

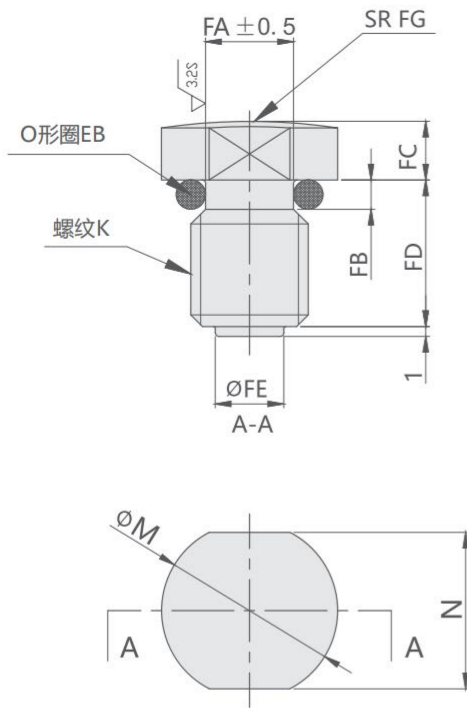

安装尺寸

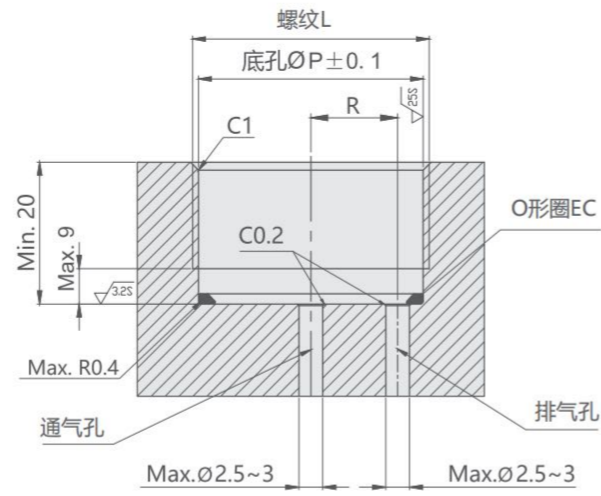

订购标示法 ORDERING INDICATION

示例: CSW-32

CSW	系列 Series	CSW
32	规格 Specification	25,32

注: 此款皆为弹簧上升型  
Note: All these models are spring rising type



气压与工件支撑力的关系

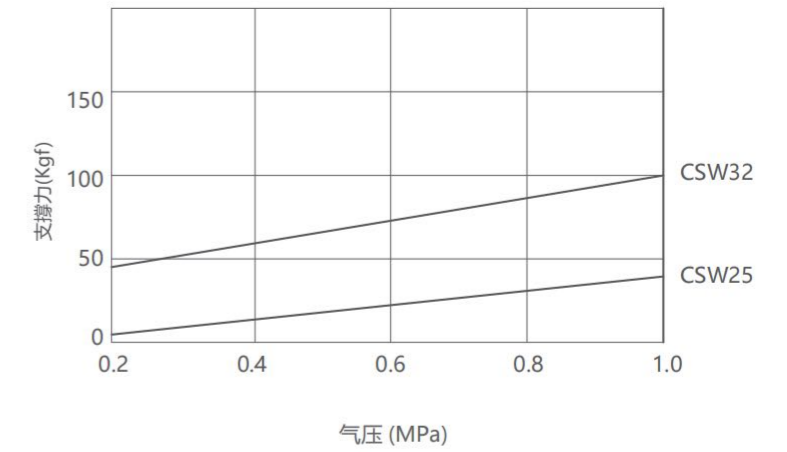

规格参数表 SPECIFICATIONS

型号 MODEL	支撑力 CLAMPING FORCE		向下行程 PISTON STROKE (mm)	气缸容积 CYLINDER CAPACITY (cm <sup>3</sup> )	上顶升力 PISTON UPWARD FORCE (N)	工作压力 RANGE OF WORK PRESSURE (MPa)	工作温度 RANGE OF TEMPERATURE (°C)
	工作气压 1.0Mpa AT 1MPa (kgf)	工作气压 0.5Mpa AT 0.5MPa (kgf)					
CSW-25	50	20	10	2.4	1.3~5.2	0.4~1.0	0~70
CSW-32	120	65	10	3.6	1.3~5.2	0.4~1.0	0~70

CSW-25尺寸图

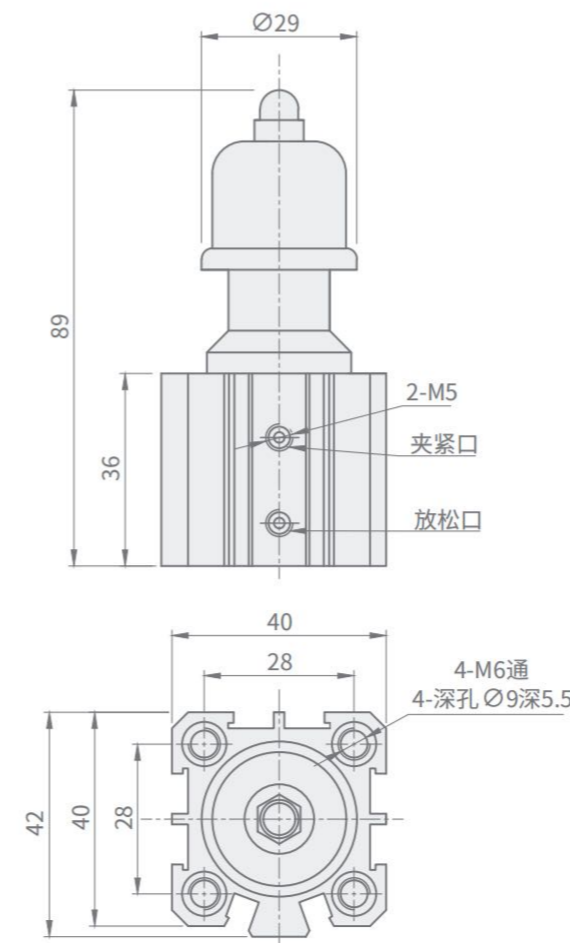

CSW-32尺寸图

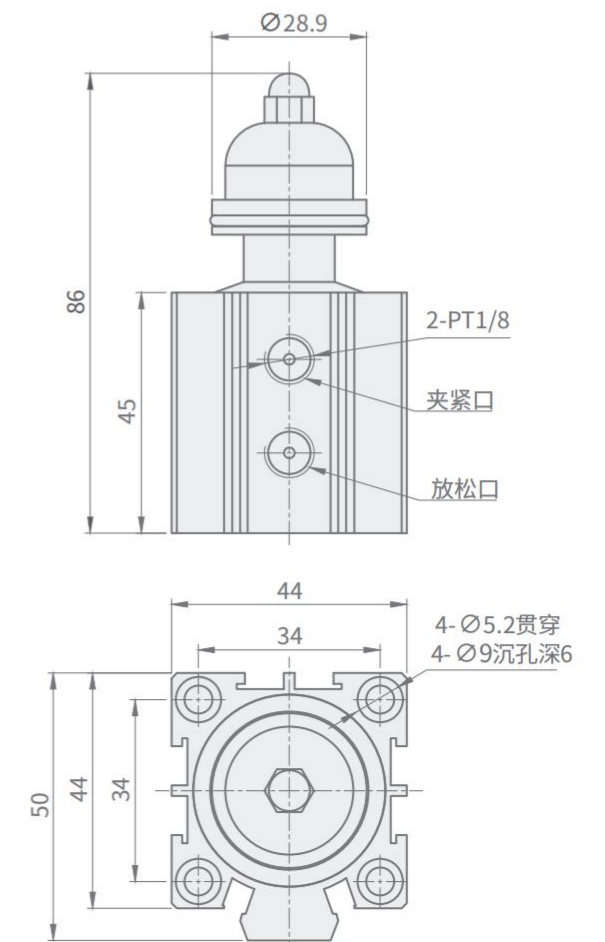

Unit:mm

型号	CSW-26AL	CSW-26BL	CSW-30AL	CSW-30BL	CSW-36AL	CSW-36BL	CSW-45AL	CSW-45BL
A	68.5	62	75.5	69	81	73	95	87
B	65.5	59	72.5	66	78	70	91	83
C	53	53	60	60	64	64	76	76
D	44	44	51	51	52	52	61	61
ØE	24.3	24.3	28.3	28.3	34.3	34.3	43.3	43.3
ØG	10	10	10	10	10	10	12	12
H (活塞杆对边宽)	8	8	8	8	8	8	10	10
J (六角对边宽)	22	22	24	24	30	30	36	36
K (公称直径X螺距)	M6x1	M6x1	M6x1	M6x1	M6x1	M6x1	M8x1.25	M8x1.25
L (公称直径X螺距)	M26x1.5	M26x1.5	M30x1.5	M30x1.5	M36x1.5	M36x1.5	M45x1.5	M45x1.5
ØM	9	9	9	9	9	9	11.5	11.5
N (对边宽)	8	8	8	8	8	8	10	10
ØFA	4.5	4.5	4.5	4.5	4.5	4.5	6	6
FB	1.5	1.5	1.5	1.5	1.5	1.5	1.9	1.9
FC	3	3	3	3	3	3	4	4
FD	7.5	7.5	7.5	7.5	7.5	7.5	9	9
ØFE	3.5	3.5	3.5	3.5	3.5	3.5	4.3	4.3
ØP	24.5	24.5	28.5	28.5	34.5	34.5	43.5	43.5
R	9	9	11	11	13	13	15	15
O型圈EA (氟橡胶硬度Hs90)	AS568-013	AS568-013	AS568-014	AS568-014	AS568-014	AS568-014	AS568-015	AS568-015
O型圈EB (氟橡胶硬度Hs70)	S5	S5	S5	S5	S5	S5	S6	S6
O型圈EC (氟橡胶硬度Hs90)	AS568-020	AS568-020	AS568-022	AS568-022	AS568-026	AS568-026	AS568-030	AS568-030

# CSWC

## 气动吸盘支撑缸

### CSWC PNEUMATIC SUCTION CUP SUPPORT CLAMP



#### 产品特性

集气动支撑缸与真空吸盘两大功能于一体，巧妙融合支撑与吸附双重力量。不仅保留了传统支撑缸的稳定支撑特性，更通过真空吸盘作用，实现了对工件的牢固吸附，为薄壁工件及轻型工件的加工提供了前所未有的稳固支撑。

#### FEATURES

It integrates the functions of a pneumatic support clamp and a vacuum suction cup, ingeniously combining the dual forces of support and adsorption. Not only does it retain the stable support characteristics of traditional support clamps, but also through the action of vacuum suction cups, it realizes the firm adsorption of workpieces, providing unprecedented stable support for the processing of thin-walled and light workpieces.

#### 订购标示法 ORDERING INDICATION

示例: CSWC-26B

#### 规格参数表 SPECIFICATIONS

型号 MODEL	行程 STROKE	气缸容量 CYLINDER CAPACITY	使用气压范围 RANGE OF WORK PRESSURE	使用环境温度 OPERATING TEMPERATURE	弹簧上升力 RISING SPRING FORCE	重量 WEIGHT
CSWC-26B	6.5mm	1.2cm <sup>3</sup>	0.4~1MPa	0~70°C	2~4N	0.25Kg

气压与工件支撑力的关系

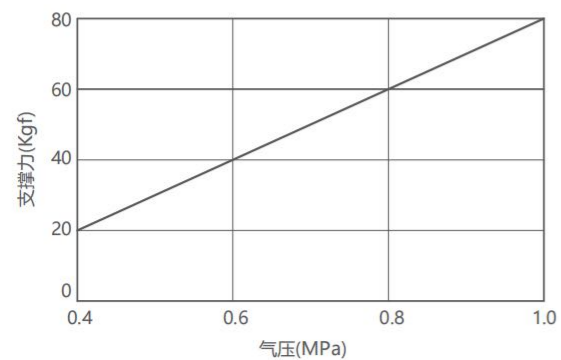

真空压力与吸附力的关系

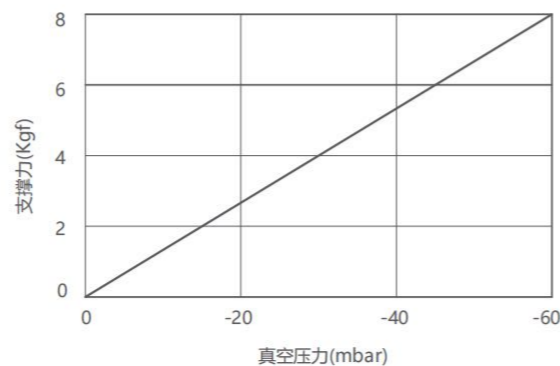

外形尺寸图

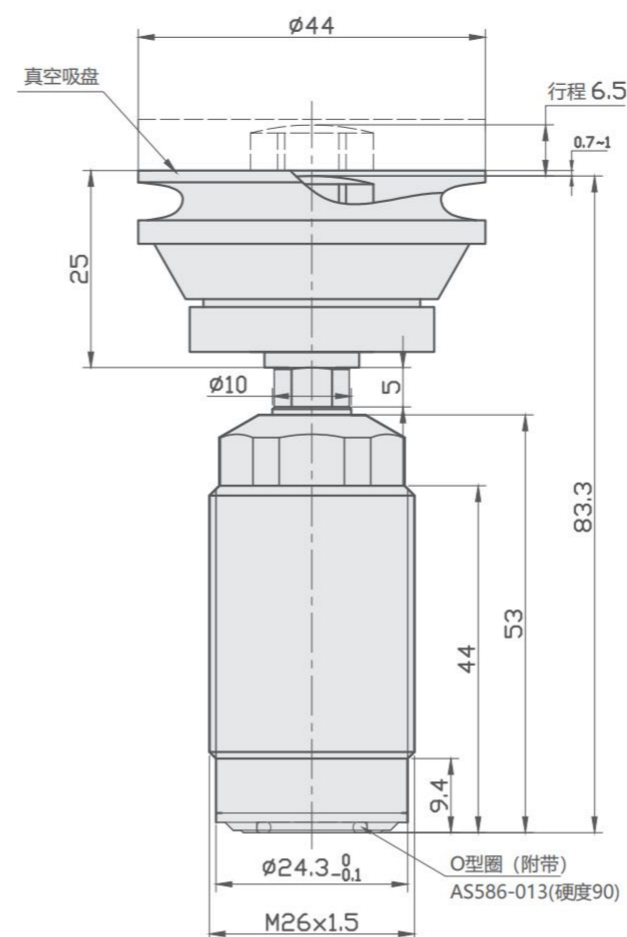

安装孔加工尺寸图

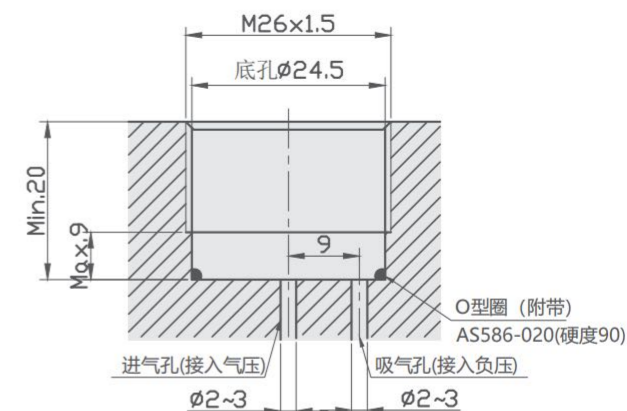

#### 注意事项

1. 支撑时先在吸气口接入负压，再对进气口接入气压；解除支撑时，停止 吸气口的负压再停止进气口气压；
2. 与压紧缸对置使用时，支撑力需要满足压紧缸压紧力+切削负荷的1.5倍以上；
3. 请通过调速阀调整支撑杆的上升动作，使气上升动作在0.5S以上；
4. 在未吸附工件时，注意防止切削屑等异物进入吸盘，以免造成支动作不良；
5. 支撑缸防尘封处会有微小泄漏，工作时请一直保持负压接入；
6. 支撑缸支撑杆不能承受偏心负荷及超出额定支撑力的负荷。

#### NOTE

1. When supporting, first connect negative pressure to the intake port, and then connect air pressure to the intake port. When releasing the support, stop the negative pressure at the intake port and then stop the air pressure at the intake port.
2. When used in opposition to the compression cylinder, the supporting force needs to be more than 1.5 times the compression force of the compression cylinder plus the cutting load.
3. Please adjust the upward movement of the support rod through the speed control valve to ensure that the upward movement of the gas is more than 0.5 seconds.
4. When the workpiece is not adsorbed, be careful to prevent foreign objects such as cutting chips from entering the suction cup to avoid poor support.
5. There may be slight leakage at the dust-proof seal of the support cylinder. Please maintain negative pressure connection all the time during operation.
6. The support rods of the support cylinder cannot bear eccentric loads or loads exceeding the rated support force.

# UCQ2

薄型铝合金气缸

## UCQ2 THIN-TYPE PNEUMATIC CYLINDER



### 产品特性 FEATURES

气缸内径 (mm)	Φ12	Φ16	Φ20	Φ25	Φ32	Φ40	Φ50	Φ63	Φ80	Φ100
标准行程 (mm)	5, 10, 15, 20, 25, 30, 35, 40, 45, 50									
行程范围 (mm)	Max:30		Max:50							
使用温度范围 (°C)	-10 ~ +60 °C									

最大操作压力: 10 kgf/cm<sup>2</sup>  
最小操作压力: 1 kgf/cm<sup>2</sup>

Max. operating pressure: 10 kgf/cm<sup>2</sup>  
Min. operation pressure: 1 kgf/cm<sup>2</sup>

### 注意事项

UCQ2系列可附磁性感应 (单动不附磁性感应)  
行程在50mm以上属于特殊定制

### NOTE

Magnetic piston(optional).  
Stroke in more than 50 mm belongs to special custom.

### 单双动气缸 DOUBLE-SINGLE ACTING CYLINDERS

单动常入型 (压回) Single acting-normally retracted piston rod type	UCQ2...S	
单动常出型 (压出) Single acting-normally extended piston rod type	UCQ2...T	
双动单轴标准型 Double acting-single end rod type	UCQ2...	
双动单轴型附磁性感应 Double acting-single end rod type(piston with magnet)	UCDQ2...	
双动双轴型 Double acting-double end rod type	UCQ2W...	
双动双轴型附磁性感应 Double acting-double end rod type(piston with magnet)	UCDQ2W...	

### 订购表示法 ORDERING INDICATION

示例: UCQ2WB20-10-SMD-A73\*2

UC	系列 Series	UC	
D	磁性感应 Magnetic	无: 无附磁性感应 D: 内附磁性感应 Nil: No magnet D: With magnet	
Q2W	活塞杆 Piston rod	Q2: 单轴 Q2: Single end rod	Q2W: 双轴 Q2W: Double end rod
B	安装方法 Mounting method	A: 两端内螺纹 A:Female thread	B: 通孔(标准) B:Hole
20	气缸内径 Cylinder inside diameter	Φ12, Φ16, Φ20, Φ25, Φ32, Φ40, Φ50, Φ63, Φ80, Φ100	
10	行程 Stroke	5, 10, 15, 20, 25 30, 35, 40, 45, 50	
S	动作型式 Acting	无: 双动 S: 单动 (压回) T: 单动 (压出)	Nil: Double acting S: Single acting(Retracted) T: Single acting(Extended)
M	轴端型式 Rod end	无: 内牙 M: 外牙	Nil: Female M: Male
D-A73	近接开关 Rod end	D-A72:AC220V 5-10mA	D-A73:DC24V 5-40mA AC100V 5-20mA
2	数量 Quantity	1:1pcs	2:2pcs

使用流体: 过滤之干燥压缩空气 Usable fluid: Oiled Dry Clean Compressed Air

### 两端内螺纹

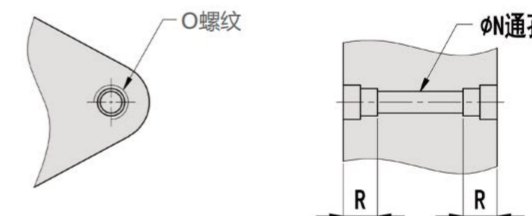

### UCQ2A / UCDQ2A

Unit:mm

缸径 BORE	12	16	20	25	32	40	50	63	80	100
O	M4×0.7	M4×0.7	M6×1.0	M6×1.0	M6×1.0	M6×1.0	M8×1.25	M10×1.5	M12×1.75	M12×1.75
R	7	7	10	10	10	10	14	18	22	22

### 杆端外螺纹

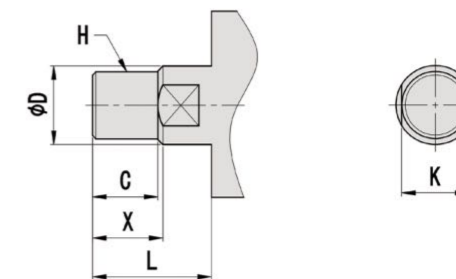

Unit:mm

缸径 BORE	12	16	20	25	32	40	50	63	80	100
C	9	10	12	15	20.5	20.5	26	26	32.5	32.5
X	10.5	12	14	17.5	23.5	23.5	28.5	28.5	35.5	35.5
ΦD	6	8	10	12	16	16	20	20	25	30
H	M5×0.8	M6×1.0	M8×1.25	M10×1.25	M14×1.5	M14×1.5	M18×1.5	M18×1.5	M22×1.5	M26×1.5
L	14	15.5	18.5	22.5	28.5	28.5	33.5	33.5	43.5	43.5
K	5	6	8	10	14	14	17	17	22	27

UCQ2B/UCDQ2B TYPE

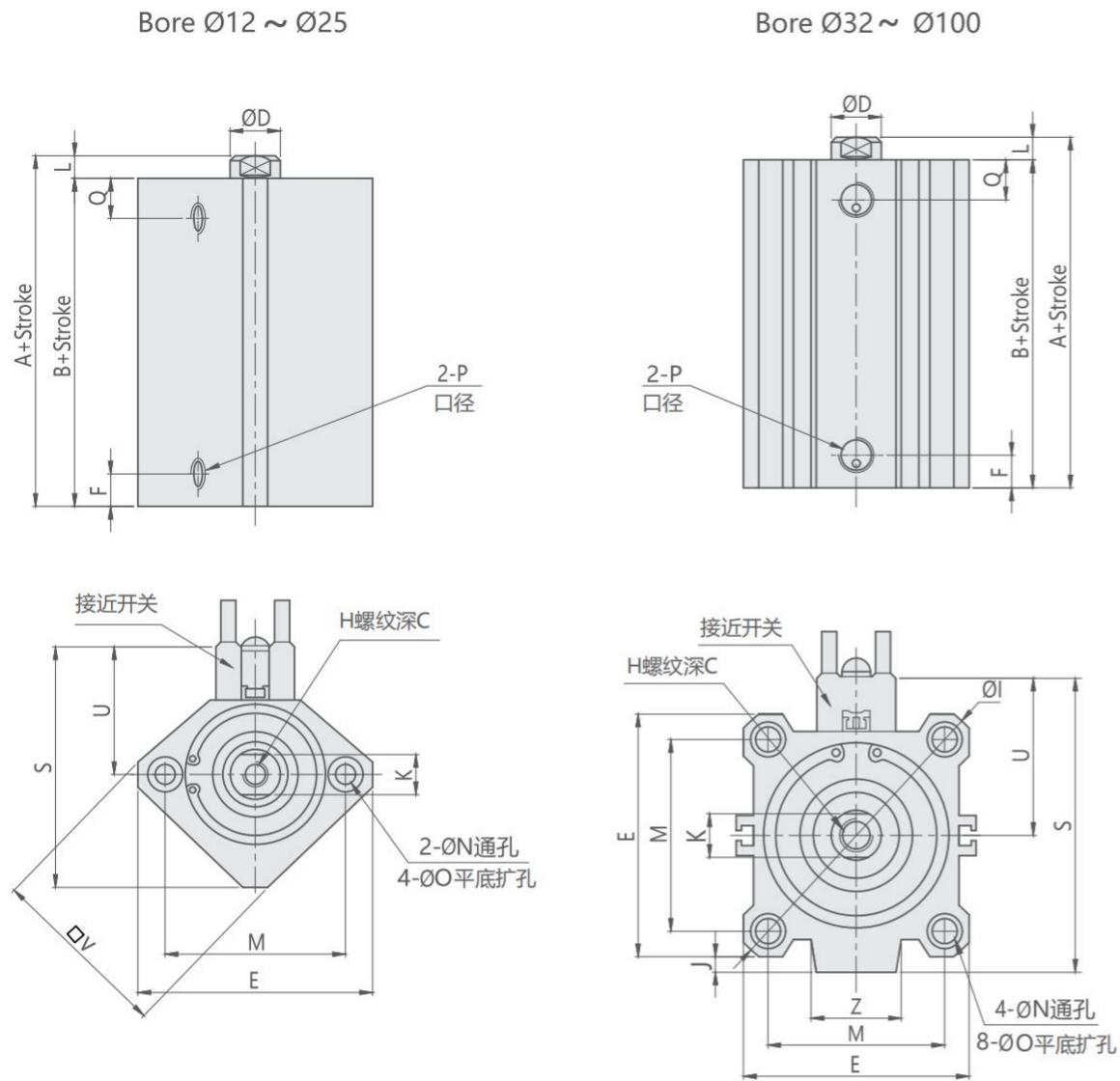

UCQ2B...S TYPE  
UCQ2A...S TYPE

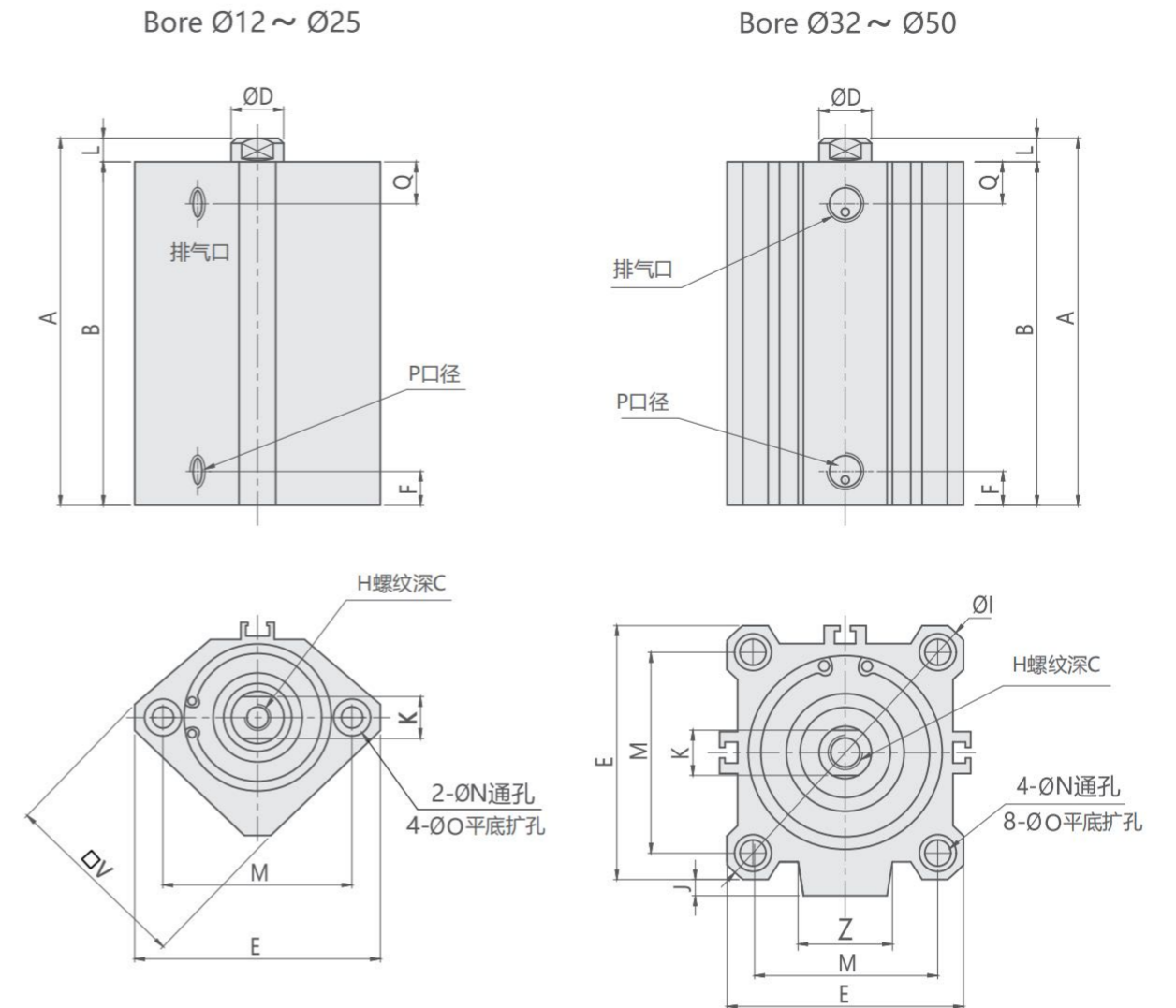

Unit:mm

缸径 DIAMETER (mm)	行程范围	A	A*	B	B*	ΦD	E	F	F*	H	C	I	J	K	L	M	ΦN	ΦO	P	P*	Q	Q*	S	U	V	Z
12	5-30	20.5	31.5	17	28	Φ6	32	6	6	M3×0.5	6	-	-	5	3.5	22	Φ3.5	Φ6.5深3.5	M5×0.8	M5×0.8	6.5	6.5	35.5	19.5	25	-
16	5-30	22	34	18.5	30.5	Φ8	38	6.5	6.5	M4×0.7	8	-	-	6	3.5	28	Φ3.5	Φ6.5深3.5	M5×0.8	M5×0.8	7	7	41.5	22.5	29	-
20	5-50	24	36	19.5	31.5	Φ10	46.8	6.5	6.5	M5×0.8	7	-	-	8	4.5	36	Φ5.5	Φ9深7	M5×0.8	M5×0.8	8	8	48	24.5	36	-
25	5-50	27.5	37.5	22.5	32.5	Φ12	52	7	7	M6×1.0	12	-	-	10	5	40	Φ5.5	Φ9深7	M5×0.8	M5×0.8	10	10	53.5	27.5	40	-
32	5 10-50	30	40	23	33	Φ16	45	8	8	M8×1.25	13	60	4.5	14	7	34	Φ5.5	Φ9深7	M5×0.8 G1/8	G1/8	9.5	9.5	58.5	31.5	-	18
40	5-50	36.5	46.5	29.5	39.5	Φ16	52	9	9	M8×1.25	13	69	5	14	7	40	Φ5.5	Φ9深7	G1/8	G1/8	10.5	10.5	66	35	-	18
50	10-50	38.5	48.5	30.5	40.5	Φ20	64	11	11	M10×1.5	15	86	7	17	8	50	Φ6.6	Φ11深8	G1/4	G1/4	11	11	80	41	-	22
63	10-50	44	54	36	46	Φ20	77	11.5	11.5	M10×1.5	15	103	7	17	8	60	Φ9	Φ14深10.5	G1/4	G1/4	15	15	93	47.5	-	22
80	10-50	53.5	63.5	43.5	53.5	Φ25	98	14	14	M16×2.0	21	132	6	22	10	77	Φ11	Φ17.5深13.5	G3/8	G3/8	15	15	112.5	57.5	-	26
100	10-50	65	75	53	63	Φ30	117	16.5	16.5	M20×2.5	27	156	6.5	27	12	94	Φ11	Φ17.5深13.5	G3/8	G3/8	22	22	132.5	67.5	-	26

注: 带[\*]号为磁性气缸尺寸 Remark: With [\*] mark is for magnetic cylinder dimensions.

Unit:mm

缸径 DIAMETER	A			B			ΦD	E	F	H	C	ΦI	J	K	L	M	ΦN	ΦO	P			Q		V	Z	
	5st	10st	20st	5st	10st	20st													5st	10st	5st	10st	20st			5st
12	25.5	30.5	-	22	27	-	Φ6	32	6	6	M3×0.5	6	-	-	5	3.5	22	Φ3.5	Φ6.5深3.5	M5×0.8	M5×0.8	-	6.5	6.5	25	-
16	27	32	-	23.5	28.5	-	Φ8	38	6.5	6.5	M4×0.7	8	-	-	6	3.5	28	Φ3.5	Φ6.5深3.5	M5×0.8	M5×0.8	-	7	7	29	-
20	29	34	-	24.5	29.5	-	Φ10	46.8	6.5	6.5	M5×0.8	9	-	-	8	4.5	36	Φ5.5	Φ9深7	M5×0.8	M5×0.8	-	8	8	36	-
25	32.5	37.5	-	27.5	32.5	-	Φ12	52	7	7	M6×1.0	12	-	-	10	5	40	Φ5.5	Φ9深7	M5×0.8	M5×0.8	-	10	10	40	-
32	35	40	-	28	33	-	Φ16	45	8	8	M8×1.25	13	Φ60	4.5	14	7	34	Φ5.5	Φ9深7	M5×0.8	G1/8	-	9.5	9.5	-	18
40	41.5	46.5	-	34.5	39.5	-	Φ16	52	9	9	M8×1.25	13	Φ69	5	14	7	40	Φ5.5	Φ9深7	G1/8	G1/8	-	10.5	10.5	-	18
50	-	48.5	58.5	-	40.5	50.5	Φ20	64	11	11	M10×1.5	15	Φ86	7	17	8	50	Φ6.6	Φ11深8	-	G1/4	G1/4	11	11	-	22

注: 以上A及B的尺寸已包含行程长度 Remark: Above A and B size contains stroke length

UCQ2B...T TYPE  
UCQ2A...T TYPE

Bore Ø12 ~ Ø25

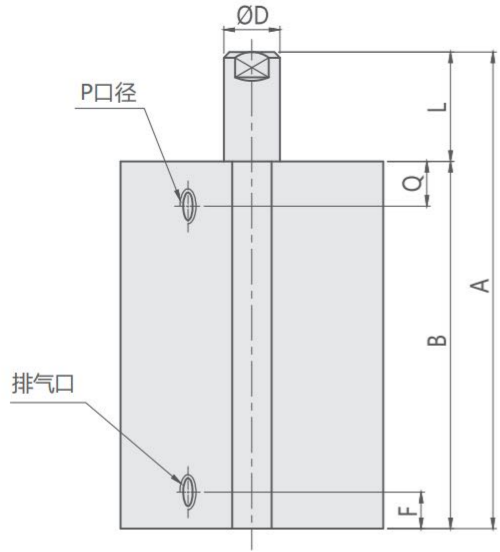

Bore Ø32 ~ Ø50

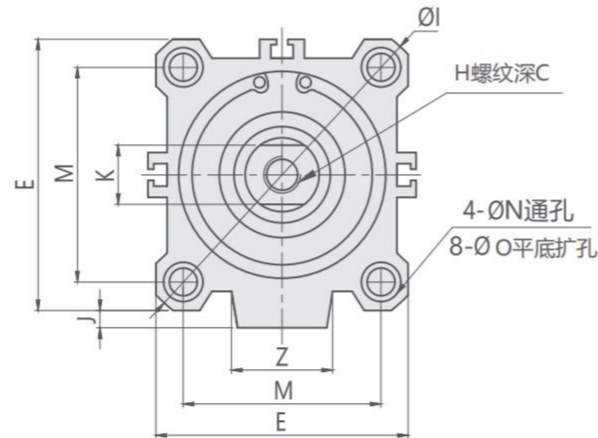
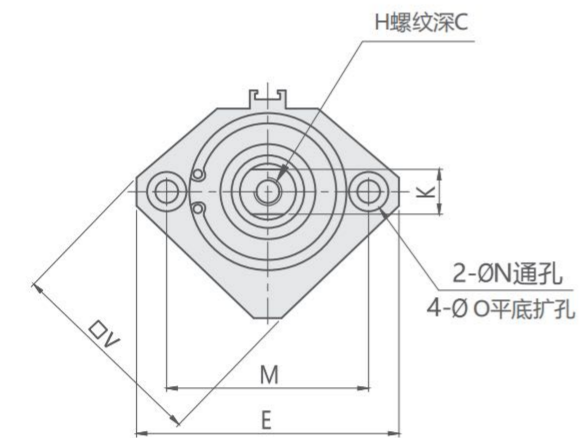
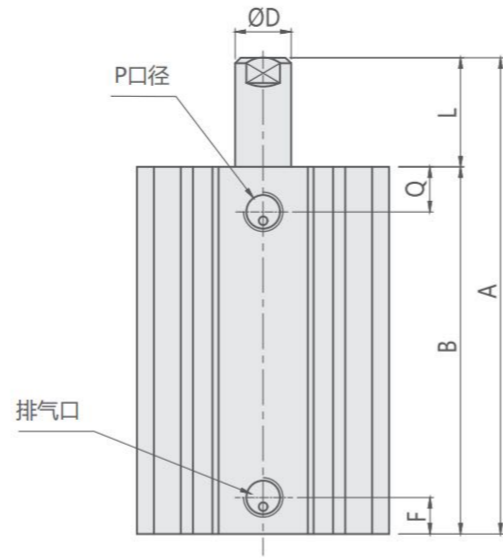

UCQ2W...B.../UCDQ2W...B...TYPE  
UCQ2W...A.../UCDQ2W...A...TYPE

Bore Ø12 ~ Ø25

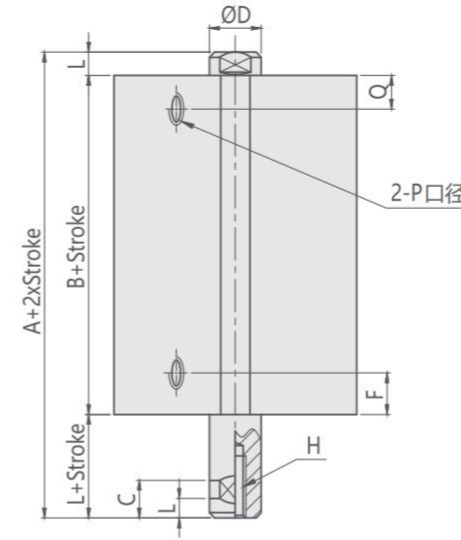

Bore Ø32 ~ Ø100

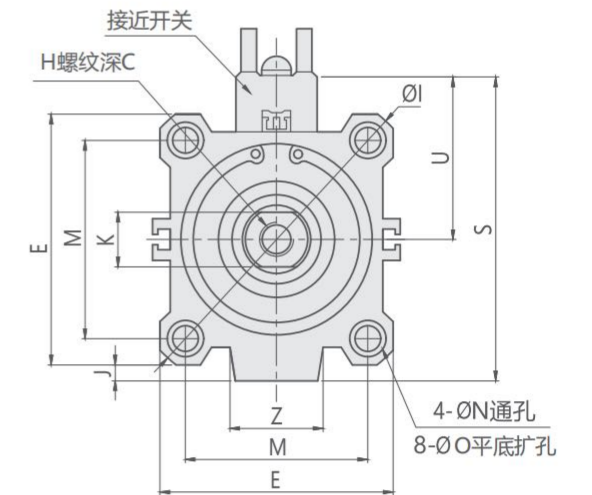
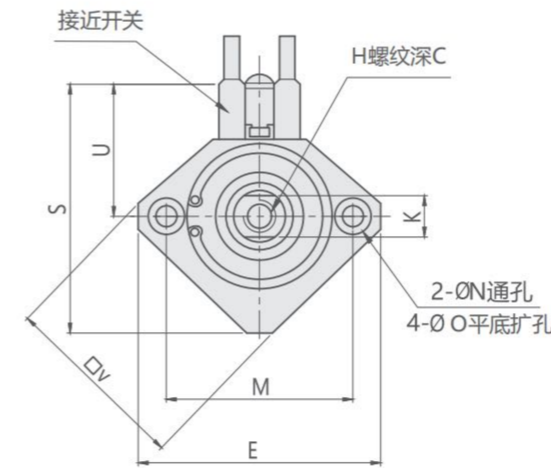
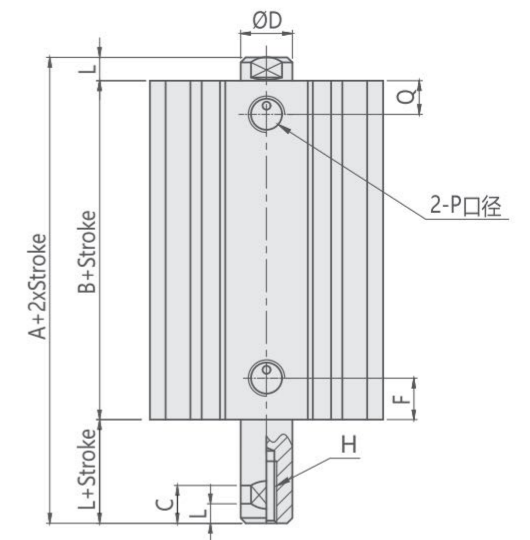

Unit:mm

缸径 DIAMETER	A			B			ΦD	E	F	H	C	ΦI	J	K	L			M	N	ΦO	P			Q			V	Z
	5st	10st	20st	5st	10st	20st									5st	10st	20st				5st	10st	20st	5st	10st	20st		
12	30.5	40.5	-	22	27	-	Φ6	32	7	7	M3×0.5	6	-	-	5	8.5	13.5	-	22	3.5	Φ6.5深3.5	M5×0.8	M5×0.8	-	6.5	6.5	25	-
16	32	42	-	23.5	28.5	-	Φ8	38	6.5	6.5	M4×0.7	8	-	-	6	8.5	13.5	-	28	3.5	Φ6.5深3.5	M5×0.8	M5×0.8	-	7	7	29	-
20	34	44	-	24.5	29.5	-	Φ10	46.8	6.5	6.5	M5×0.8	9	-	-	8	9.5	14.5	-	36	5.5	Φ9深7	M5×0.8	M5×0.8	-	8	8	36	-
25	37.5	47.5	-	27.5	32.5	-	Φ12	52	7	7	M6×1.0	12	-	-	10	10	15	-	40	5.5	Φ9深7	M5×0.8	M5×0.8	-	10	10	40	-
32	40	50	-	28	33	-	Φ16	45	8	8	M8×1.25	13	Φ60	4.5	14	12	17	-	34	5.5	Φ9深7	M5×0.8	G1/8	-	9.5	9.5	-	18
40	46.5	56.5	-	34.5	39.5	-	Φ16	52	9	9	M8×1.25	13	Φ69	5	14	12	17	-	40	5.5	Φ9深7	G1/8	G1/8	-	10.5	10.5	-	18
50	-	58.5	78.5	-	40.5	50.5	Φ20	64	11	11	M10×1.5	15	Φ86	7	17	-	18	28	50	6.6	Φ11深8	-	G1/4	G1/4	11	11	-	22

注:以上A及B的尺寸已包含行程长度 Remark: Above A and B size contains stroke length.

Unit:mm

缸径 DIAMETER (mm)	行程范围	A	A*	B	B*	ΦD	E	F	F*	H	C	ΦI	J	K	L	M	ΦN	ΦO	P	P*	Q	Q*	S	U	V	Z
12	5-30	32.2	39.4	25.5	32.4	Φ6	32	6.5	6.5	M3×0.5	6	-	-	5	3.5	22	Φ3.5	Φ6.5深3.5	M5×0.8	M5×0.8	6.5	6.5	35.5	19.5	25	-
16	5-30	33	43	26	36	Φ8	38	7	7	M4×0.7	8	-	-	6	3.5	28	Φ3.5	Φ6.5深3.5	M5×0.8	M5×0.8	7	7	41.5	22.5	29	-
20	5-50	35	47	26	38	Φ10	46.8	8	8	M5×0.8	9	-	-	8	4.5	36	Φ5.5	Φ9深7	M5×0.8	M5×0.8	8	8	48	24.5	36	-
25	5-50	39	49	29	39	Φ12	52	10	10	M6×1.0	12	-	-	10	5	40	Φ5.5	Φ9深7	M5×0.8	M5×0.8	10	10	53.5	27.5	40	-
32	5-50	44.5	54.5	30.5	40.5	Φ16	45	9.5	9.5	M8×1.25	13	Φ60	4.5	14	7	34	Φ5.5	Φ9深7	M5×0.8 G1/8	G1/8	9.5	9.5	58.5	31.5	-	18
40	5-50	54	64	40	50	Φ16	52	10.5	10.5	M8×1.25	13	Φ69	5	14	7	40	Φ5.5	Φ9深7	G1/8	G1/8	10.5	10.5	66	35	-	18
50	10-50	56.5	66.5	40.5	50.5	Φ20	64	11	11	M10×1.5	15	Φ86	7	17	8	50	Φ6.6	Φ11深8	G1/4	G1/4	11	11	80	41	-	22
63	10-50	58	68	42	52	Φ20	77	15	15	M10×1.5	15	Φ103	7	17	8	60	Φ9	Φ14深10.5	G1/4	G1/4	15	15	93	47.5	-	22
80	10-50	71	81	51	61	Φ25	98	15	15	M16×2.0	21	Φ132	6	22	10	77	Φ11	Φ17.5深13.5	G3/8	G3/8	15	15	112.5	57.5	-	26
100	10-50	84.5	94.5	60.5	70.5	Φ30	117	22	22	M20×2.5	27	Φ156	6.5	27	12	94	Φ11	Φ17.5深13.5	G3/8	G3/8	22	22	132.5	67.5	-	26

注:(\*)号为磁性气缸尺寸 Remark: With (\*) mark is for magnetic cylinder dimensions.

# SDA

## 薄型铝合金气缸

### SDA THIN-TYPE PNEUMATIC CYLINDER



#### 产品特性 FEATURES

气缸内径 (mm)	Φ12	Φ16	Φ20	Φ25	Φ32	Φ40	Φ50	Φ63	Φ80	Φ100
标准行程 (mm)	5, 10, 15, 20, 25, 30, 35, 40, 45, 50									
行程范围 (mm)	Max:60		Max:100		Max:120					
使用温度范围 (°C)	-10 ~ +60 °C									

最大操作压力: 10kgf/cm<sup>2</sup>  
 最小操作压力: 1 kgf/cm<sup>2</sup>  
 作动方式: 复动式

Max. operating pressure: 10kgf/cm<sup>2</sup>  
 Min. operation pressure: 1 kgf/cm<sup>2</sup>  
 Double acting

#### 注意事项

行程在50mm以上属于特殊定制

#### NOTE

Stroke in more than 50 mm belongs to special custom.

#### 双动气缸 DOUBLE ACTING CYLINDERS

双动单轴标准型 Double acting-single end rod type	SDA	
双动单轴型附磁性感应 Double acting-single end rod type (piston with magnet)	SDAS	
双动双轴型标准 Double acting-double end rod type	SDAD	
双动双轴型附磁性感应 Double acting-double end rod type (piston with magnet)	SDADS	
双动双轴可调行程 Adjustable stroke cylinder(adjustable stroke:A:25mm,B:50mm)	SDAJ	
双动双轴可调行程附磁性感应型 Adjustable stroke cylinder (piston with magnet)(adjustable stroke:A:25mm,B:50mm)	SDAJS	

#### 杆端外螺纹

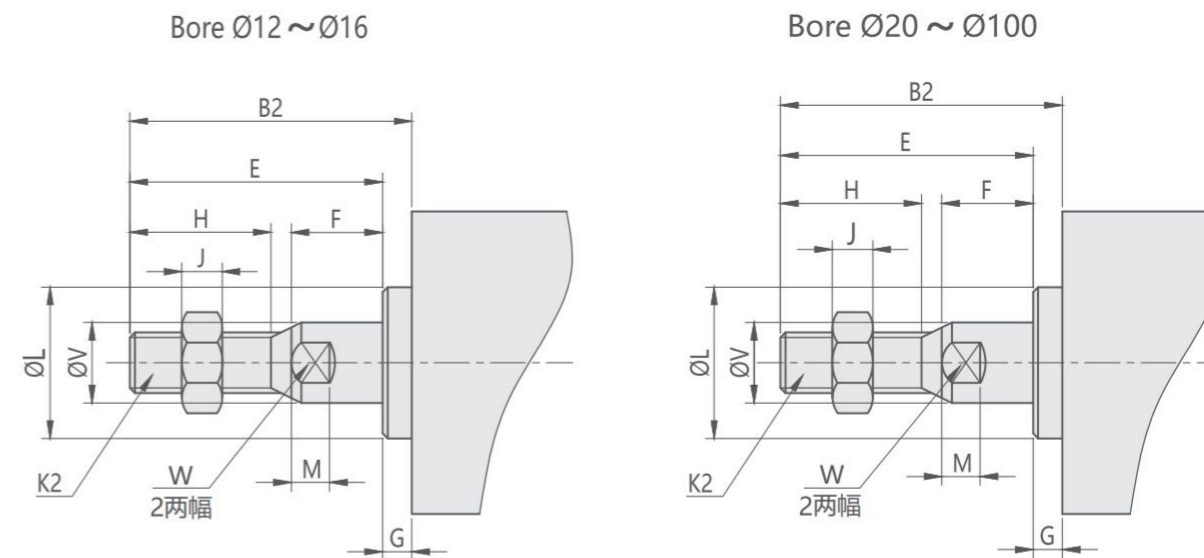

#### 订购标示法 ORDERING INDICATION

##### 示例: SDADS20-10-B

SDA	系列 Series	SDA/SDAD/SDAJ
D	活塞杆 Piston rod	无:单轴 D:双轴 J:双轴可调 Nil: Single end rod D: Double end rod J: Double rod of adjustable stroke rod
S	磁性感应 Magnetic	无:无附磁性感应 S:内附磁性感应 Nil: No magnet S: With magnet
20	气缸内径 Cylinder inside diameter	Φ12, Φ16, Φ20, Φ25, Φ32, Φ40, Φ50, Φ63, Φ80, Φ100
10	行程 Stroke	5, 10, 15, 20, 25, 30, 35, 40, 45, 50
B	轴端型式 Rod end	无: 内牙 B: 外牙 Nil: Female B: Male

使用流体: 过滤之干燥压缩空气 Usable fluid: Oiled Dry Clean Compressed Air

DIAMETER 缸径	B2	E	F	G	H	J	K2	L	M	V	W
12	17	16	4	1	10	4	M5×0.8	10.2	2.8	6	5
16	17.5	16	4	1.5	10	4	M5×0.8	11	2.8	6	5
20	20.5	19	4	1.5	13	5	M6×1.0	15	2.8	8	6
25	23	21	4	2	15	6	M8×1.25	17	2.8	10	8
32	25	22	4	3	15	6	M10×1.25	22	2.8	12	10
40	35	32	4	3	25	8	M14×1.5	28	2.8	16	14
50	37	33	5	4	25	11	M18×1.5	38	2.8	20	17
63	37	33	5	4	25	11	M18×1.5	40	2.8	20	17
80	44	39	6	5	30	13	M22×1.5	45	4	25	22
100	50	45	7	5	35	13	M26×1.5	55	4	32	27

SDA/SDAS TYPE

Bore Ø12 ~ Ø16

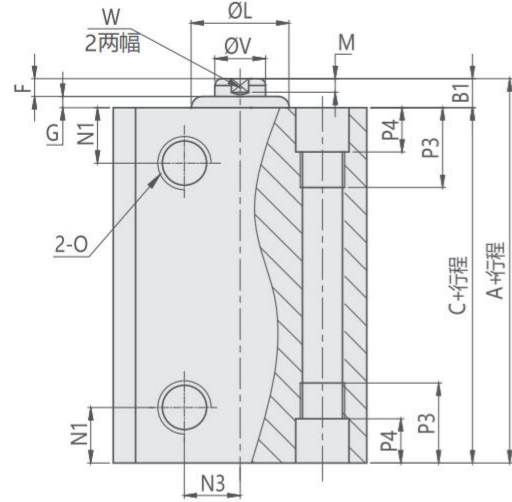

Bore Ø20 ~ Ø100

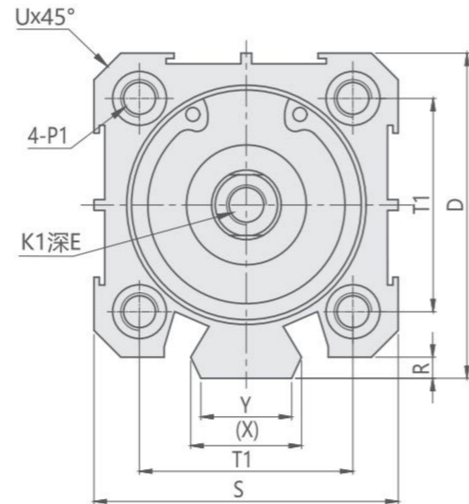
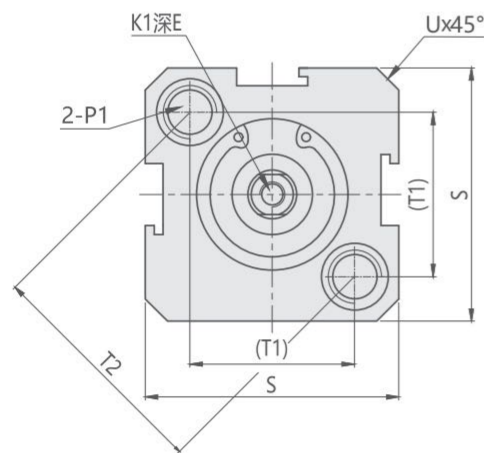
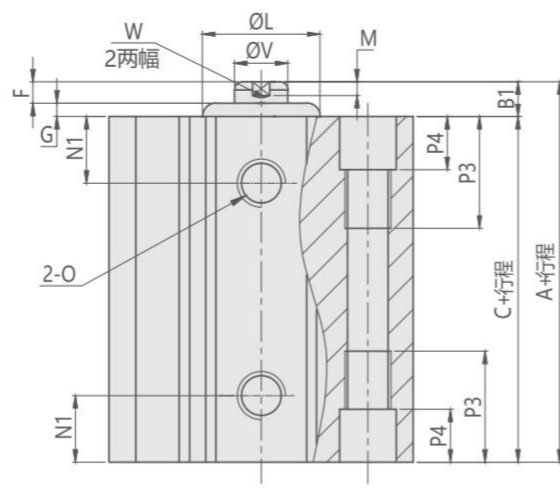

Unit:mm

缸径 DIAMETER	标准型			附磁型			D	E	F	G	K1	L	M	N1	N3	O	P1	P3	P4	R	S	T1	T2	U	V	W	X	Y	
	A	B1	C	A	B1	C																							
12	22	5	17	32	5	27	-	6	6	4	1	M3×0.5	10.2	2.8	6.3	6	M5×0.8	双边Φ6.5牙M5×0.8 通孔Φ4.2	12	4.5	-	25	16.2	23	1.6	6	5	-	-
16	24	5.5	18.5	34	5.5	28.5	-	6	6	4	1.5	M3×0.5	11	2.8	7.3	6.5	M5×0.8	双边Φ6.5牙M5×0.8 通孔Φ4.2	12	4.5	-	29	19.8	28	1.6	6	5	-	-
20	25	5.5	19.5	35	5.5	29.5	36	8	8	4	1.5	M4×0.7	15	2.8	7.5	-	M5×0.8	双边Φ6.5牙M5×0.8 通孔Φ4.2	14	4.5	2	34	24	-	2.1	8	6	11.3	10
25	27	6	21	37	6	31	42	10	10	4	2	M5×0.8	17	2.8	8	-	M5×0.8	双边Φ8.2牙M6×1.0 通孔Φ4.6	15	5.5	2	40	28	-	3.1	10	8	12	10
32	31.5	7	24.5	41.5	7	34.5	50	12	12	4	3	M6×1.0	22	2.8	9	-	PT1/8	双边Φ8.2牙M6×1.0 通孔Φ4.6	16	5.5	6	44	34	-	2.15	12	10	18.3	15
40	33	7	26	43	7	36	58.5	12	12	4	3	M8×1.25	28	2.8	10	-	PT1/8	双边Φ10牙M8×1.25 通孔Φ6.5	20	7.5	6.5	52	40	-	2.25	16	14	21.3	16
50	37	9	28	47	9	38	71.5	15	15	5	4	M10×1.5	38	2.8	10.5	-	PT1/4	双边Φ11牙M8×1.25 通孔Φ6.5	25	8.5	9.5	62	48	-	4.15	20	17	30	20
63	41	9	32	51	9	42	84.5	15	15	5	4	M10×1.5	40	2.8	11.8	-	PT1/4	双边Φ11牙M8×1.25 通孔Φ6.5	25	8.5	9.5	75	60	-	3.15	20	17	28.7	20
80	52	11	41	62	11	51	104	15	20	6	5	M14×1.5	45	4	14.5	-	PT3/8	双边Φ14牙M12×1.75 通孔Φ9.2	25	10.5	10	94	74	-	3.65	25	22	36	26
100	63	12	51	73	12	61	124	18	20	7	5	M18×1.5	55	4	20.5	-	PT3/8	双边Φ17.5牙M14×2 通孔Φ11.3	30	13	10	114	90	-	3.65	32	27	35	26

SDAD/SDAS TYPE

Bore Ø12 ~ Ø16

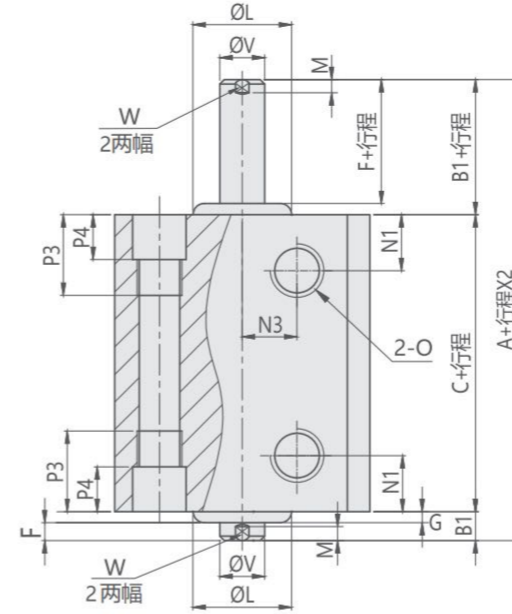

Bore Ø20 ~ Ø100

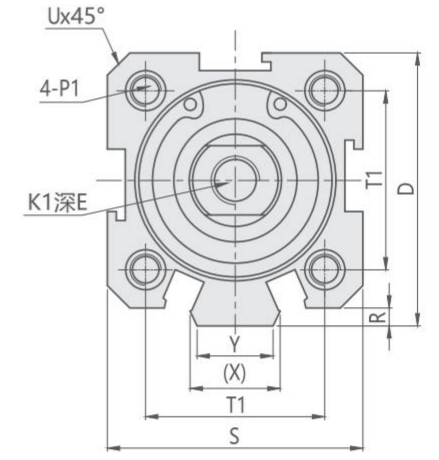
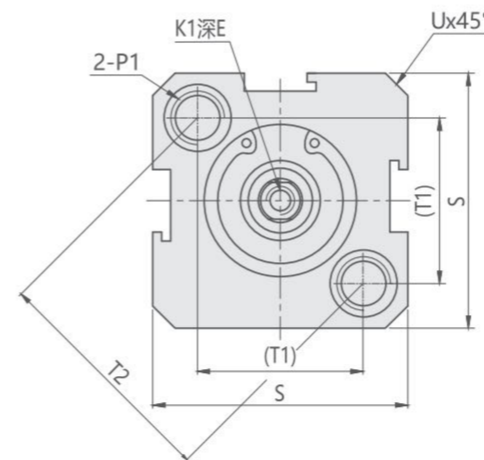
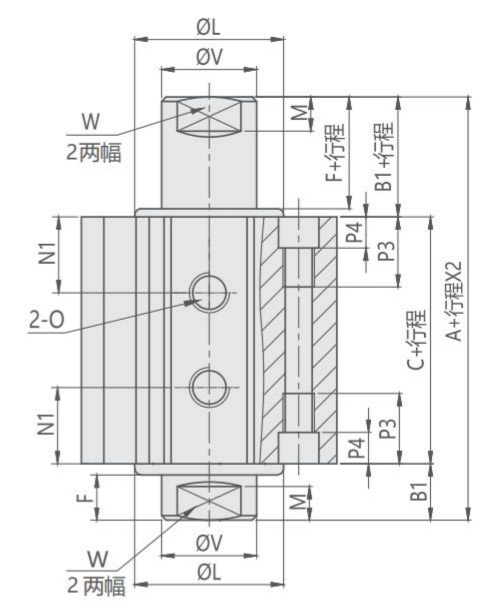

Unit:mm

缸径 DIAMETER	标准型			附磁型			D	E	F	G	K1	L	M	N1	N3	O	P1	P3	P4	R	S	T1	T2	U	V	W	X	Y	
	A	B1	C	A	B1	C																							
12	27	5	17	37	5	27	-	6	4	1	M3×0.5	10.2	2.8	6.3	6	M5×0.8	双边Φ6.5牙M5×0.8 通孔Φ4.2	12	4.5	-	25	16.2	23	1.6	6	5	-	-	
16	29.5	5.5	18.5	39.5	5.5	28.5	-	6	4	1.5	M3×0.5	11	2.8	7.3	6.5	M5×0.8	双边Φ6.5牙M5×0.8 通孔Φ4.2	12	4.5	-	29	19.8	28	1.6	6	5	-	-	
20	30.5	5.5	19.5	40.5	5.5	29.5	36	8行程=5时为6.5	4	1.5	M4×0.7	15	2.8	7.5	-	M5×0.8	双边Φ6.5牙M5×0.8 通孔Φ4.2	14	4.5	2	34	24	-	2.1	8	6	11.3	10	
25	33	6	21	43	6	31	42	10行程=5时为7	4	2	M5×0.8	17	2.8	8	-	M5×0.8	双边Φ8.2牙M6×1.0 通孔Φ4.6	15	5.5	2	40	28	-	3.1	10	8	12	10	
32	38.5	7	24.5	48.5	7	34.5	50	8	12	4	3	M6×1.0	22	2.8	9	-	PT1/8	双边Φ8.2牙M6×1.0 通孔Φ4.6	16	5.5	6	44	34	-	2.15	12	10	18.3	15
40	40	7	26	50	7	36	58.5	9	12	4	3	M8×1.25	28	2.8	10	-	PT1/8	双边Φ10牙M8×1.25 通孔Φ6.5	20	7.5	6.5	52	40	-	2.25	16	14	21.3	16
50	46	9	28	56	9	38	71.5	11	15	5	4	M10×1.5	38	2.8	10.5	-	PT1/4	双边Φ11牙M8×1.25 通孔Φ6.5	25	8.5	9.5	62	48	-	4.15	20	17	30	20
63	50	9	32	60	9	42	84.5	11	15	5	4	M10×1.5	40	2.8	11.8	-	PT1/4	双边Φ11牙M8×1.25 通孔Φ6.5	25	8.5	9.5	75	60	-	3.15	20	17	28.7	20
80	63	11	41	73	11	51	104	14	20	6	5	M14×1.5	45	4	14.5	-	PT3/8	双边Φ14牙M12×1.75 通孔Φ9.2	25	10.5	10	94	74	-	3.65	25	22	36	26
100	75	12	51	85	12	61	124	18	20	7	5	M18×1.5	55	4	20.5	-	PT3/8	双边Φ17.5牙M14×2 通孔Φ11.3	30	13	10	114	90	-	3.65	32	27	35	26

SDAJ/SDAS TYPE

Bore  $\varnothing 12 \sim \varnothing 16$

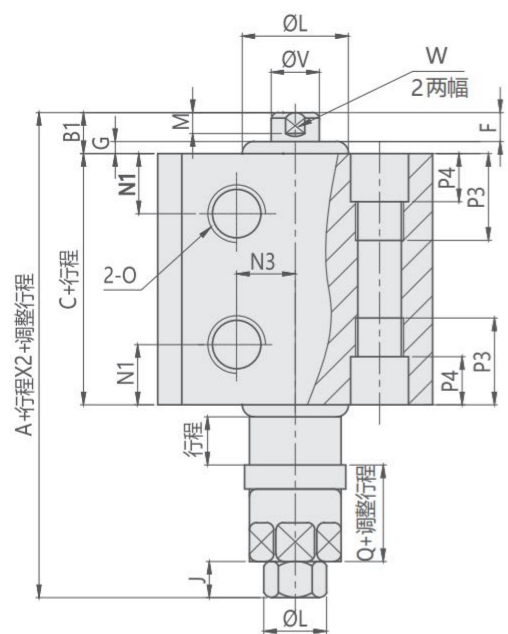

Bore  $\varnothing 20 \sim \varnothing 100$

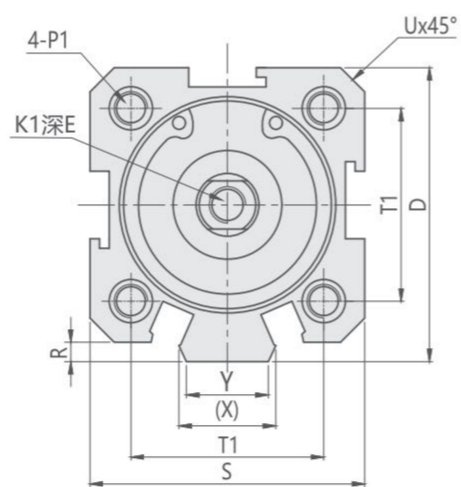
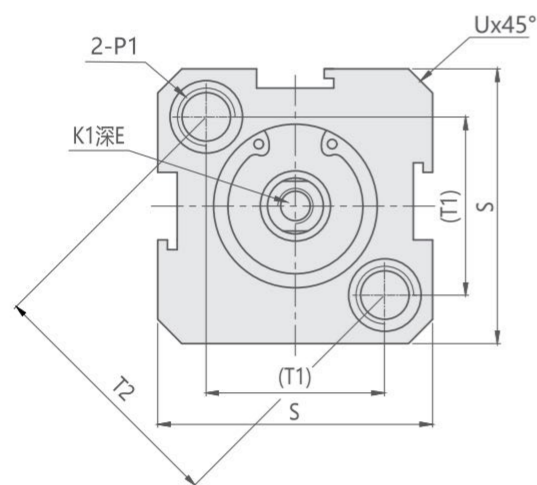
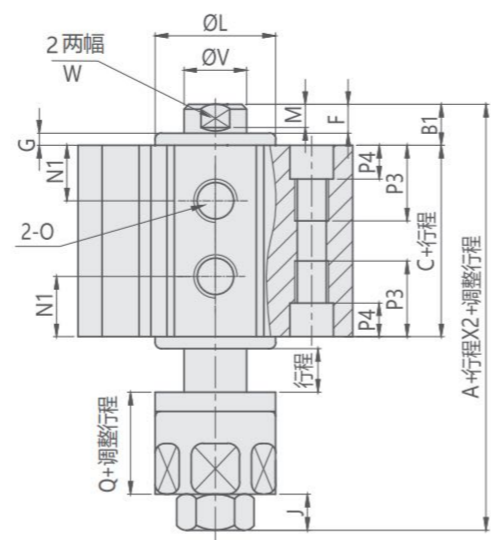

Unit:mm

缸径 DIAMETER	标准型			附磁型			D	E	F	G	J	K1	L	M	N1	N3	O	P1	P3	P4	R	S	T1	T2	U	V	W	X	Y	
	A	B1	C	A	B1	C																								
12	40	5	17	50	5	27	-	6	4	1	4	M3×0.5	10.2	2.8	6.3	6	M5×0.8	双边:Φ6.5牙M5×0.8 通孔Φ4.2	12	4.5	-	25	16.2	23	1.6	6	5	-	-	
16	42.5	5.5	18.5	52.5	5.5	28.5	-	6	4	1.5	4	M3×0.5	11	2.8	7.3	6.5	M5×0.8	双边:Φ6.5牙M5×0.8 通孔Φ4.2	12	4.5	-	29	19.8	28	1.6	6	5	-	-	
20	47.5	5.5	19.5	57.5	5.5	29.5	36	8(行程=5时为6.5)	4	1.5	5	M4×0.7	15	2.8	7.5	-	M5×0.8	双边:Φ6.5牙M5×0.8 通孔Φ4.2	14	4.5	2	34	24	-	2.1	8	6	11.3	10	
25	55	6	21	65	6	31	42	10(行程=5时为7)	4	2	6	M5×0.8	17	2.8	8	-	M5×0.8	双边:Φ8.2牙M6×1.0 通孔Φ4.6	15	5.5	2	40	28	-	3.1	10	8	12	10	
32	61.5	7	24.5	71.5	7	34.5	50	8	12	4	3	6	M6×1.0	22	2.8	9	-	PT1/8	双边:Φ8.2牙M6×1.0 通孔Φ4.6	16	5.5	6	44	34	-	2.15	12	10	18.3	15
40	65	7	26	75	7	36	58.5	9	12	4	3	8	M8×1.25	28	2.8	10	-	PT1/8	双边:Φ10牙M8×1.25 通孔Φ6.5	20	7.5	6.5	52	40	-	2.25	16	14	21.3	16
50	73	9	28	83	9	38	71.5	11	15	5	4	11	M10×1.5	38	2.8	10.5	-	PT1/4	双边:Φ11牙M8×1.25 通孔Φ6.5	25	8.5	9.5	62	48	-	4.15	20	17	30	20
63	77	9	32	87	9	42	84.5	11	15	5	4	11	M10×1.5	40	2.8	11.8	-	PT1/4	双边:Φ11牙M8×1.25 通孔Φ6.5	25	8.5	9.5	75	60	-	3.15	20	17	28.7	20
80	94	11	41	104	11	51	104	14	20	6	5	13	M14×1.5	45	4	14.5	-	PT3/8	双边:Φ14牙M12×1.75 通孔Φ9.2	25	10.5	10	94	74	-	3.65	25	22	36	26
100	105	12	51	115	12	61	124	18	20	7	5	13	M18×1.5	55	4	20.5	-	PT3/8	双边:Φ17.5牙M14×2 通孔Φ11.3	30	13	10	114	90	-	3.65	32	27	35	26



# DE

## 无拉杆式铝合金气缸

### DE PNEUMATIC CYLINDER



#### 产品特性 FEATURES

气缸内径 (mm)	Φ32	Φ40	Φ50	Φ63	Φ80	Φ100
标准行程 (mm)	25, 50, 75, 100, 125, 150, 175, 200, 250, 300, 350, 400, 450, 500					
使用温度范围 (°C)	-10 ~ +60 °C					

最大操作压力: 10kgf/cm<sup>2</sup>  
最小操作压力: 1 kgf/cm<sup>2</sup>

Max. operating pressure: 10kgf/cm<sup>2</sup>  
Min. operation pressure: 1 kgf/cm<sup>2</sup>

#### 注意事项

DEB系列可附磁性感应  
本系列空气缸符合ISO6430规格

#### NOTE

Magnetic piston(optional).  
DE series cylinders according to ISO 6430 (Bore size Φ32-Φ100)

#### 双动气缸 DOUBLE ACTING CYLINDERS

双动单轴标准型 Double acting-single end rod type	DEB	
双动单轴附磁性感应 Double acting-single end rod type (piston with magnet)	DEB...M	
双动双轴标准型 Double acting-double end rod type	DED	
双动双轴附磁性感应 Double acting-double end rod type (piston with magnet)	DED...M	
双动双轴可调行程 Adjustable stroke cylinder (adjustable stroke: A:25mm, B:50mm)	DEN...N...A DEN...N...B	
双动双轴可调行程附磁性感应型 Adjustable stroke cylinder (piston with magnet) (adjustable stroke: A:25mm, B:50mm)	DEN...M...A DEN...M...B	

#### 订购标示法 ORDERING INDICATION

示例: DEN50M125-B-FA-Y-LN21R\*2

DEN	系列 Series	DEB/DED/DEN			
50	气缸内径 Cylinder inside diameter	Φ32, Φ40, Φ50, Φ63 Φ80, Φ100			
M	磁性感应 Magnetic	N: 无附磁性感应 M: 内附磁性感应 N: No magnet M: With magnet			
125	行程 Stroke	25, 50, 75, 100, 125, 150, 175, 200, 225, 300, 350, 400, 450, 500			
B	可调行程 Adjustable stroke	A: 可调25mm A:Adjustable 25mm	B: 可调50mm B:Adjustable 50mm	C: 可调75mm C: Adjustable 75mm	
FA-Y	配件 Accessories	FA:前法兰 Front flange		CA:单耳座 Male pivot	
		FB:后法兰 After flange		CB:双耳座 Female pivot	
		TC:中间轴销 Intermediate pivot		LB:支架 Axial foot	
				Y:Y型接明 Rod clevis	
				G:鱼眼接头 Oscillating eye	
				K:浮动接头 Compensating joint	
LN21R	近接开关 Sensor switch				
2	数量 Quantity	1:1pc	2:2pcs		

使用流体: 过滤之干燥压缩空气 Usable fluid: Oiled Dry Clean Compressed Air

#### DEB TYPE

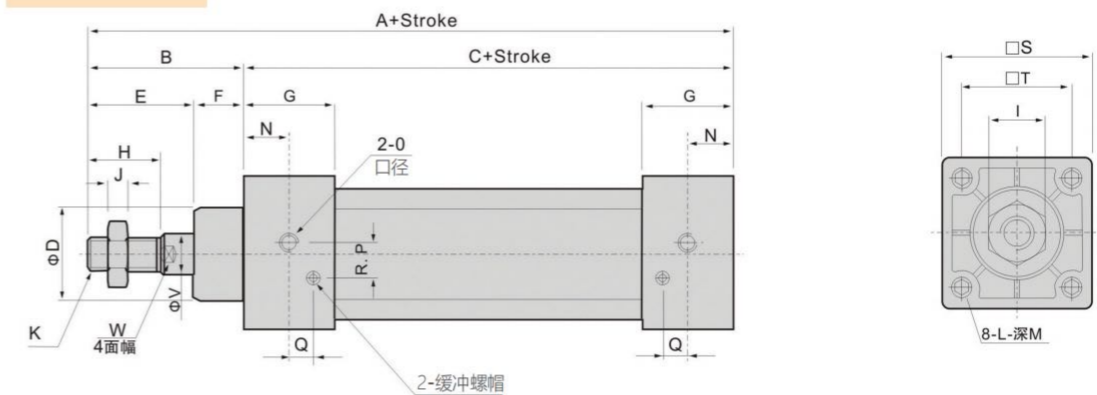

#### DED TYPE

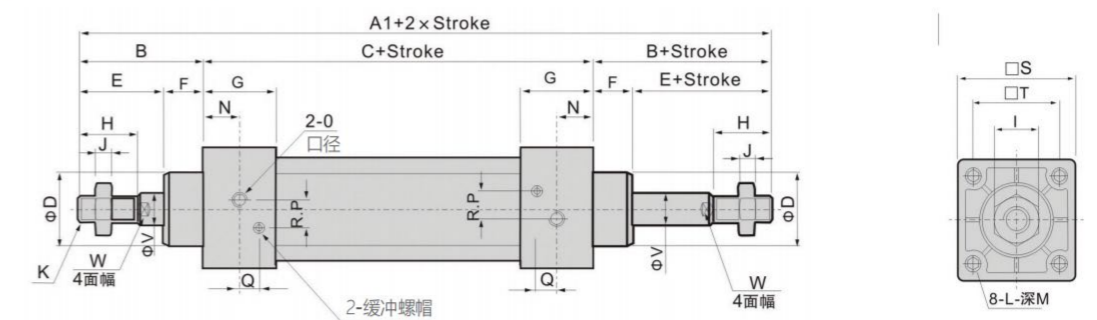

Unit:mm

缸径 DIAMETER	A1	A	B	C	D	E	F	G	H	I	J	K	L	M	N	O	P	Q	R	S	T	V	W
32	187	140	47	93	28	32	15	27.5	22	17	6	M10×1.25	M6×1	9.5	13.75	G1/8	3.5	7.5	7	45	33	12	10
40	191	142	49	93	32	34	15	27.5	24	17	7	M12×1.25	M6×1	9.5	13.5	G1/4	6	8.2	9	50	37	16	14
50	207	150	57	93	38	42	15	27.5	32	23	8	M16×1.5	M6×1	9.5	13.5	G1/4	8.5	8.2	9	62	47	20	17
63	210	153	57	96	38	42	15	27.5	32	23	8	M16×1.5	M8×1.25	9.5	13.5	G3/8	7	8.2	8.5	75	56	20	17
80	258	183	75	108	47	54	21	33	40	26	10	M20×1.5	M10×1.5	11.5	16.5	G3/8	10	9.5	14	94	70	25	22
100	264	189	75	114	47	54	21	33	40	26	10	M20×1.5	M10×1.5	11.5	16.5	G1/2	11	9.5	14	112	84	25	22

注: 附磁型与不附磁型之尺寸相同 Remark: The dimensions of magnetic type are same as no-magnetic type

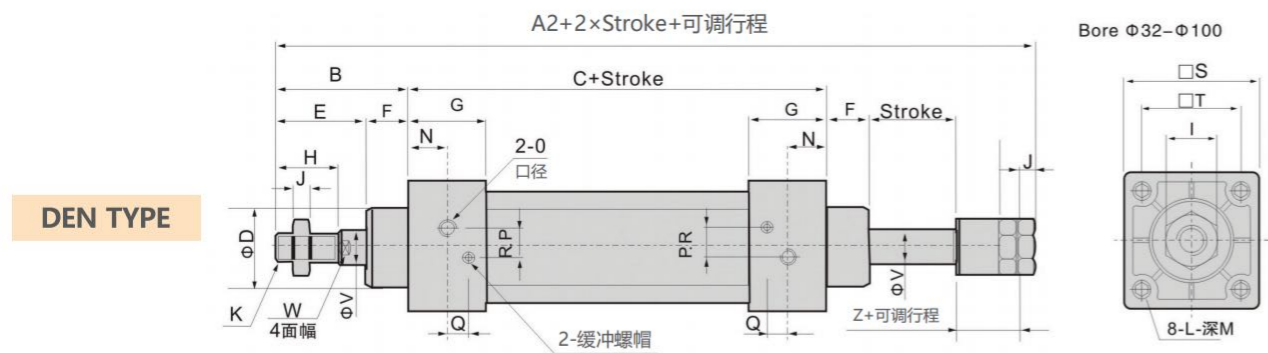

DEN TYPE

缸径 DIAMETER	A2	B	C	D	E	F	G	H	I	J	K	L	M	N	O	P	Q	R	S	T	V	W	Z
32	182	47	93	28	32	15	27.5	22	17	6	M10×1.25	M6×1	9.5	13.75	G1/8"	3.5	7.5	7	45	33	12	10	21
40	185	49	93	32	34	15	27.5	24	17	7	M12×1.25	M6×1	9.5	13.5	G1/4"	6	8.2	9	50	37	16	14	21
50	196	57	93	38	42	15	27.5	32	23	8	M16×1.5	M6×1	9.5	13.5	G1/4"	8.5	8.2	9	62	47	20	17	23
63	199	57	96	38	42	15	27.5	32	23	8	M16×1.5	M8×1.25	9.5	13.5	G3/8"	7	8.2	8.5	75	56	20	17	23
80	243	75	108	47	54	21	33	40	26	10	M20×1.5	M10×1.5	11.5	16.5	G3/8"	10	9.5	14	94	70	25	22	29
100	249	75	114	47	54	21	33	40	26	10	M20×1.5	M10×1.5	11.5	16.5	G1/2"	11	9.5	14	112	84	25	22	29

注：附磁型与不附磁型之尺寸相同 Remark: The dimensions of magnetic type are same as no-magnetic type

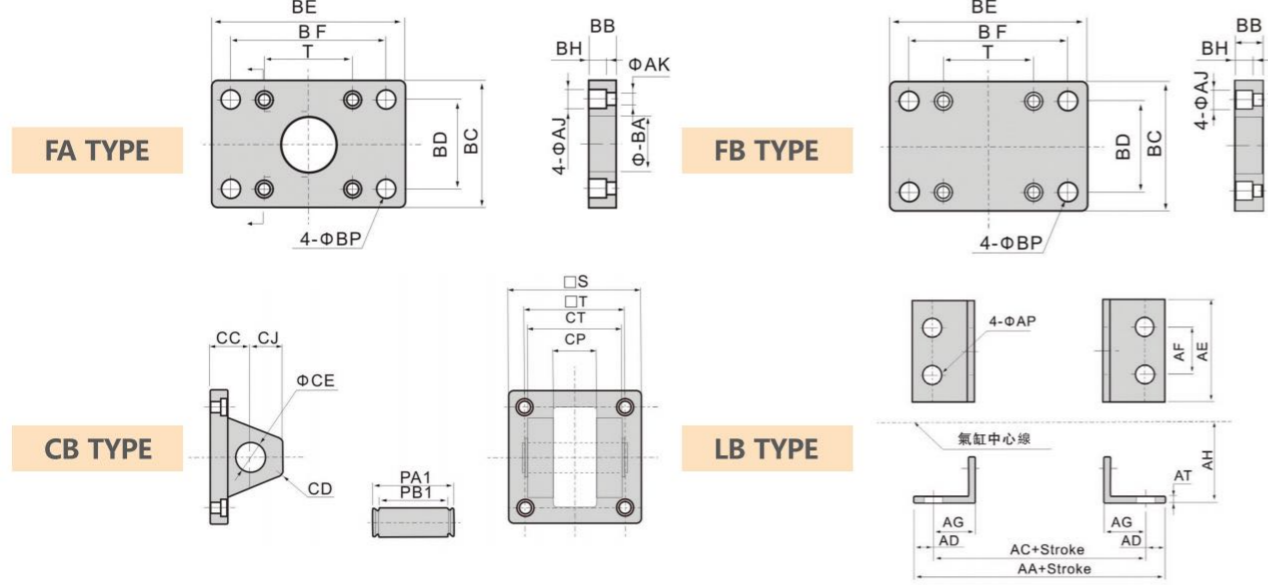

FA TYPE

FB TYPE

CB TYPE

LB TYPE

安装配件尺寸 ACCESSORIES

缸径 DIAMETER	FA前法兰										FB后法兰										
	BA	BB	BC	BD	BE	BF	BH	AJ	AK	BP	T	BB	BC	BD	BE	BF	BH	AJ	AK	BP	T
32	28.3	10	47	33	72	58	6.5	10.5	6.5	7	33	10	47	33	72	58	6.5	10.5	6.5	7	33
40	32.3	10	52	36	84	70	6.5	10.5	6.5	7	37	10	52	36	84	70	6.5	10.5	6.5	7	37
50	38.3	10	65	47	104	86	6.5	13.5	8.5	9	47	10	65	47	104	86	6.5	13.5	8.5	9	47
63	38.3	12	76	56	116	98	8.5	13.5	8.5	9	56	12	76	56	116	98	8.5	13.5	8.5	9	56
80	47.3	16	95	70	143	119	10.5	16.6	10.5	12	70	16	95	70	143	119	10.5	16.6	10.5	12	70
100	47.3	16	115	84	162	138	10.5	16.6	10.5	12	84	16	115	84	162	138	10.5	16.6	10.5	12	84

缸径 DIAMETER	CB双耳座										LB支架									
	CC	CD	CE	CJ	CP	CT	PA1	PB1	S	T	AA	AC	AD	AE	AF	AG	AH	AP	AT	
32	19	3	12	13	16.3	32	41	33.5	48	33	153	134	9.5	50	33	20.5	28	9	3.2	
40	19	3	14	13	20.3	44	51.8	45.5	50	37	169	140	14.5	57	36	23.5	30	12	3.2	
50	19	5	14	15	20.3	52	60.3	54	62	47	173	149	12	68	47	28	36.5	12	3.2	
63	19	5	14	15	20.3	52	60.3	54	75	56	184	158	13	80	56	31	41	12	3.2	
80	32	8	20	21	32.3	64	73.8	65.5	94	70	200	168	16	97	70	30	49	14	4	
100	32	8	20	21	32.3	64	73.8	65.5	112	84	210	174	18	112	84	30	57	14	4	

G鱼眼接头 OSCILLATING EYE

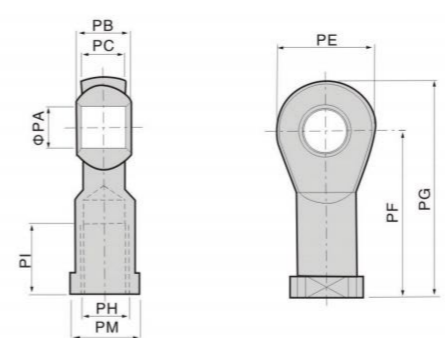

缸径 DIAMETER	G鱼眼接头								K浮动接头							
	PA	PB	PC	PE	PF	PG	PH	PI	PM	MA	MB	MC	MF	MG	MH	MI
32	10	14	11	26	43	56	M10×1.25	21	17	58	22	7	M10×1.25	12	26	17
40	12	16	12	30	50	65	M12×1.25	24	19	58	22	8	M12×1.25	12	28	19
50	16	21	15	38	64	83	M16×1.5	33	22	90	27	10	M16×1.5	14	45	27
63	16	21	15	38	64	83	M16×1.5	33	22	90	27	10	M16×1.5	14	45	27
80	20	25	18	46	77	100	M20×1.5	40	32	102	29	13	M20×1.5	18	53	33
100	20	25	18	46	77	100	M20×1.5	40	32	102	29	13	M20×1.5	18	53	33

TC TYPE

CA TYPE

TC-M TYPE

Y接头 Y ROD CIEVIS(WITH PIN)

安装配件尺寸 ACCESSORIES

缸径 DIAMETER	TC中间轴销										TC-M 支撑架									
	EB	EC	ED	EE	EG	EP	ET	S	HA	HB	HC	HD	HE	HF	HI	HJ	HQ	HR	HT	HP
40	113	63	37	63	25	25	30	45.5	110	80	45.5	22	109	86	81.5	50	23	2	12	12
50	126	76	47	76	25	25	30	55.5	110	80	55.5	22	122	99	88	50	23	2	12	12
63	138	88	56	88	25	25	30	68.5	110	80	68.5	22	134	111	94	50	23	2	12	12
80	164	114	70	114	25	25	30	87.5	120	80	87.5	22	160	137	127	70	23	2	14	14
100	182	132	84	132	25	25	40	107.5	120	80	107.5	22	178	155	136	70	23	2	14	14

缸径 DIAMETER	CA单耳座								Y接头							
	S	T	DC	DD	DE	DJ	DQ	NA	NC	ND	NH	NM	NP	NQ		
32	48	33	34	14	12	14	16	19	10	40	M10×1.25	10	20	52		
40	50	37	34	14	14	14	20	25.4	12	48	M12×1.25	12	24	62		
50	62	47	34	15	14	15	20	32	16	64	M16×1.5	16	32	83		
63	75	56	34	15	14	15	20	32	16	64	M16×1.5	16	32	83		
80	94	70	48	20	20	20	32	44.4	20	80	M20×1.5	20	40	105		
100	112	84	48	20	20	20	32	44.4	20	80	M20×1.5	20	40	105		

## CTK

## 夹紧气缸

## CTK CLAMPING CYLINDER



## 产品特性

气缸缸体使用铝合金材料，经气化处理，更具耐磨及耐腐蚀性。采用无给油轴承及耐磨密封环使用寿命长。

多个配管位置可供选择。

附缓冲型可有效减缓封缸盖之冲击。

附磁性环型可搭配选用磁簧开关。

## FEATURES

The body of the cylinder is made of aluminum alloy, after the vaporization of aluminum processing, it is more wear resistance and corrosion resistance. With the no oil bearing and wear-resisting sealing ring, the cylinder has a long service life. Multiple piping position to choose.

The cylinder with the buffer action can effectively slow speed and weaken the impact force on the cylinder head.

The cylinder with a magnetic ring can match with magnetic reed switch.

最大操作压力: 10kgf/cm<sup>2</sup>

最小操作压力: 1 kgf/cm<sup>2</sup>

作动方式: 复动式

Max. operating pressure: 10kgf/cm<sup>2</sup>

Min. operation pressure: 1 kgf/cm<sup>2</sup>

Double acting

## 订购标示法 ORDERING INDICATION

示例: CTK-50-100MY

CTK	系列 Series	CTK	
50	气缸内径 Cylinder inside diameter	Φ50, Φ63	
100	行程 Stroke	50, 75, 100, 125, 150	
M	附磁石 With magnet	无: 无附磁石 M: 附磁石	Nil: without magnet M: Magnet
Y	接头配件 Accessory	无 Y: Y接头 I: I接头	Nil: no accessory Y: Y joint I: I joint

使用流体: 过滤之干燥压缩空气  
Usable fluid: Oiled Dry Clean Compressed Air

## 使用范例

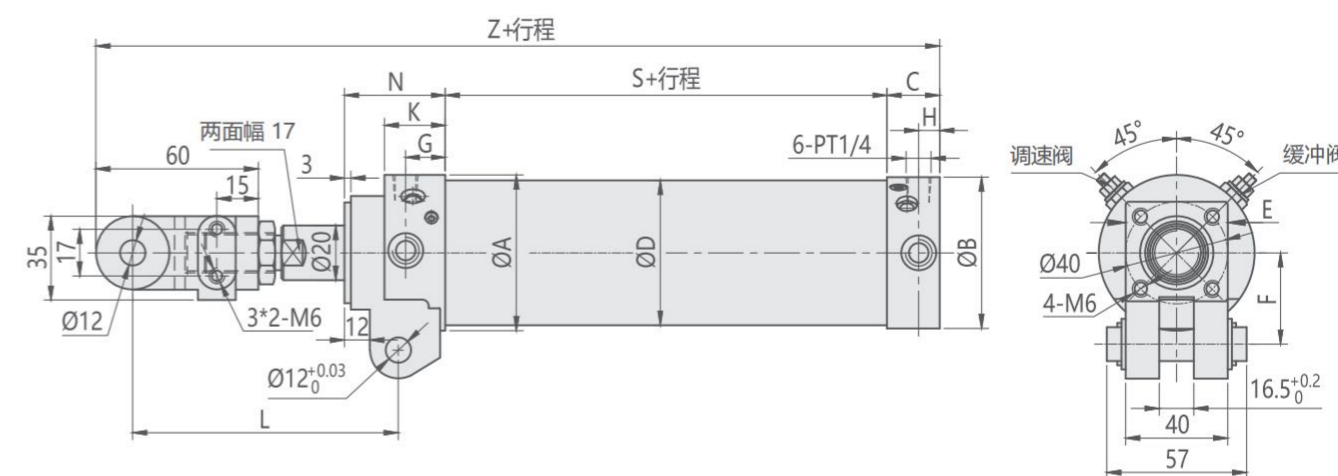
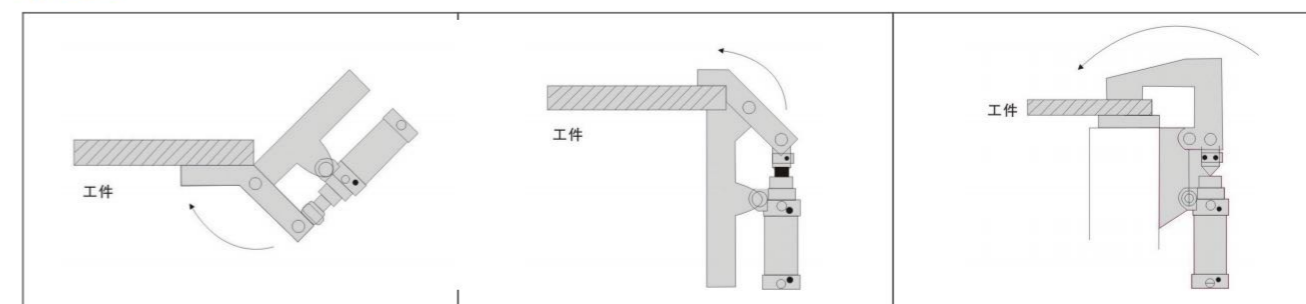

## I 接头

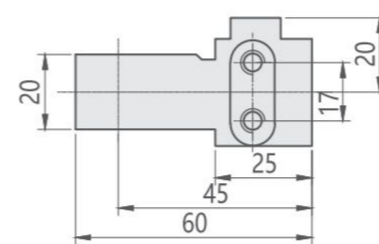

## Y 接头

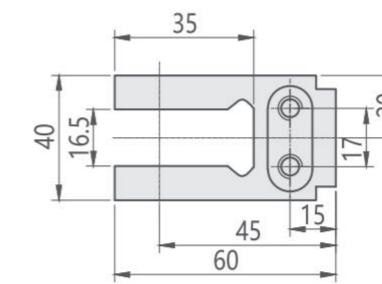

## 插销

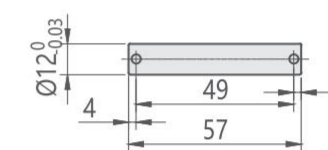

开口销: Ø1/8"x3/4"L

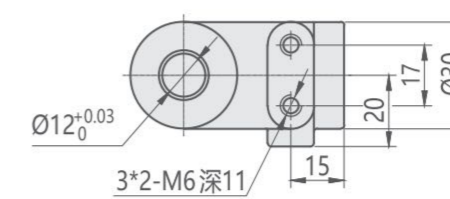
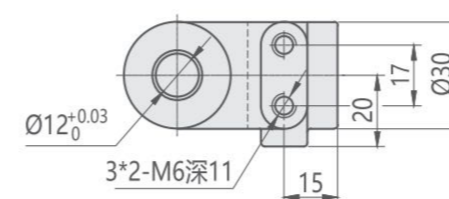

Unit:mm

缸径BORE	ΦA	ΦB	ΦD	C	E	F	G	H	K	N	L	S	Z
50	60	58	58	25	40	36	19	10	29	48	97	46	205
63	74	72	69	25	50	36	19	10	29	48	97	46	205

# 机械夹爪

## GRIPPERS

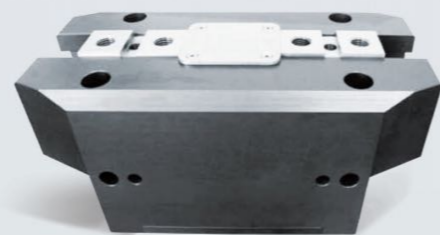

### 产品特性

利用锥度滑动的楔形面压驱动方式。  
简洁可靠的结构。  
开放式设计，可自由搭配夹持工件。

### 规格参数表 SPECIFICATION

产品规格	开闭范围(mm)	最大附件长度(mm)	连接口	理论夹持力(开)	理论夹持力(闭)	空气消耗量/周期(cm <sup>3</sup> )
CH-125	70	70	PF(G)1/8	848N	830N	987.6

使用流体: 过滤之干燥压缩空气  
Usable fluid: Oiled Dry Clean Compressed Air

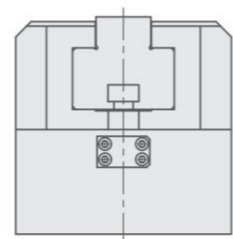
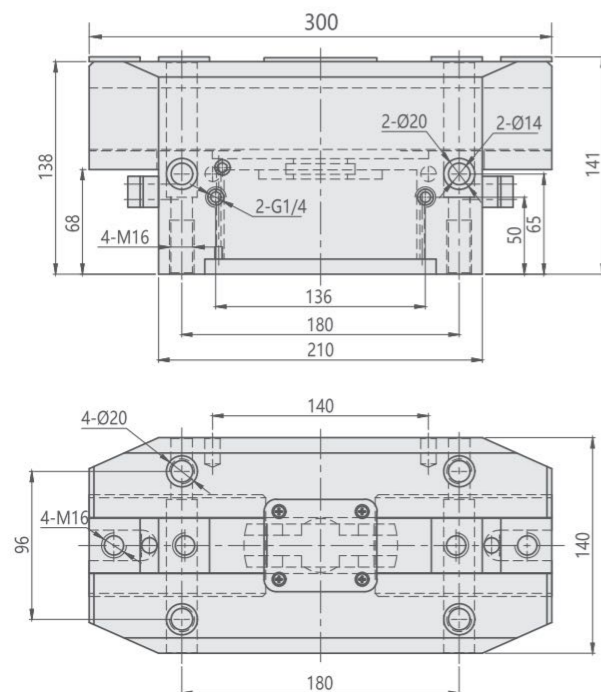

# AHP

## 气动增压泵

### AHP PNEUMATIC BOOSTER PUMP



#### 产品特性

利用空气驱动增压泵,输出油压力,作为油缸之动力源,流量大于一般增压倍数,连续式增压,作动缸无增压行程之限制。以空气调压阀调整压力,达到增压倍数即停止驱动,油压降时,泵将会自动补偿,特别适用于长时间油压夹持,节省能源,不产生油温,经济方便。

A型:安装ISO规格油路板及电磁阀,适用于单动或复动油缸。安装电磁球阀改善内泄量问题,保固气动泵使用寿命。  
B型:配管座P.T孔,可连接油压手动阀操作。  
双泵组合可选购增压比,特别适用于低压与高压同时使用之夹具。

油箱体积小,节省空间,安装容易。

#### FEATURES

The booster pump is driven by air to output hydraulic pressure. As a power source for hydraulic cylinder, Its flow rate is bigger than that of a conventional booster. Continuous pressure boosting and no limitation of booster stroke for the acting cylinder.

Pressure adjustment is made by an air pressure regulation valve. Once pressure reaches the desired valve, drive stops immediately. In case pressure drops, the pump will compensate pressure automatically. The series is especially ideal for longtime hydraulic clamping application. Also features energy saving no oil temperature growth, economical and convenient.

A type: Equipped with ISO approved manifold and solenoid valve, Applicable for single acting or double acting hydraulic cylinder. B type: Equipped with pipe block with P.T ports, permitting for connecting to a manual control valve for operational control.

When double-pump is applied, you can select the boost pressure ratio. It is especially suitable for jig and fixture which requires high and low pressure operation together.

Reduced oil tank volume for space saving and convenient installation.

最大操作压力: 6 kgf/cm<sup>2</sup>

Max. operating pressure: 6 kgf/cm<sup>2</sup>

#### 订购标示法 ORDERING INDICATION

示例: AHP-10-S-A-AC110V

AHP	系列 Series	AHP
10	增压倍数 Booster pressure rate	05,10,16,25,44
S	泵浦形式	S: 单泵 Single pump D: 双泵 Double pump
A	控制型式 Control type	A: ISO规格油路板 Manifold, magnet valve B: 配管座P.T孔 Distributing tube seat P.T port
AC110V	线圈型式 Coil type	AC110V, AC220V, DC24V

#### 单泵组外形尺寸

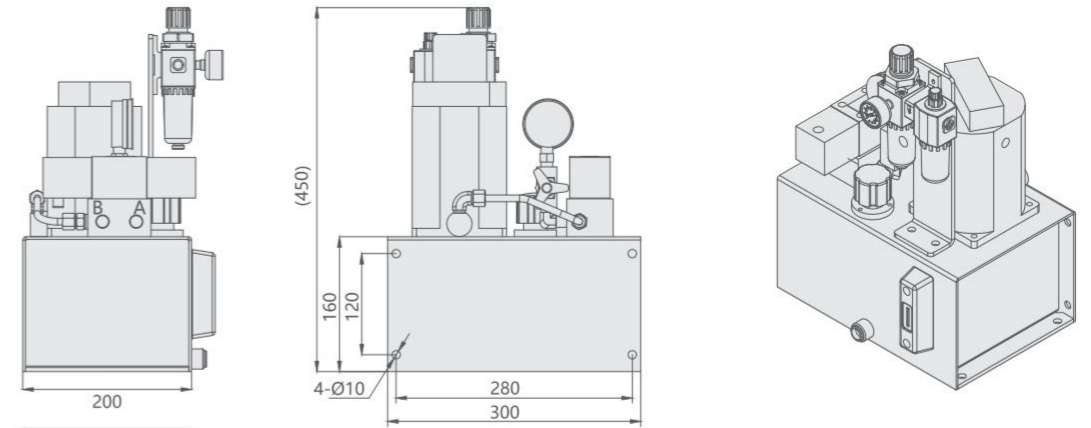

#### 双泵组外形尺寸

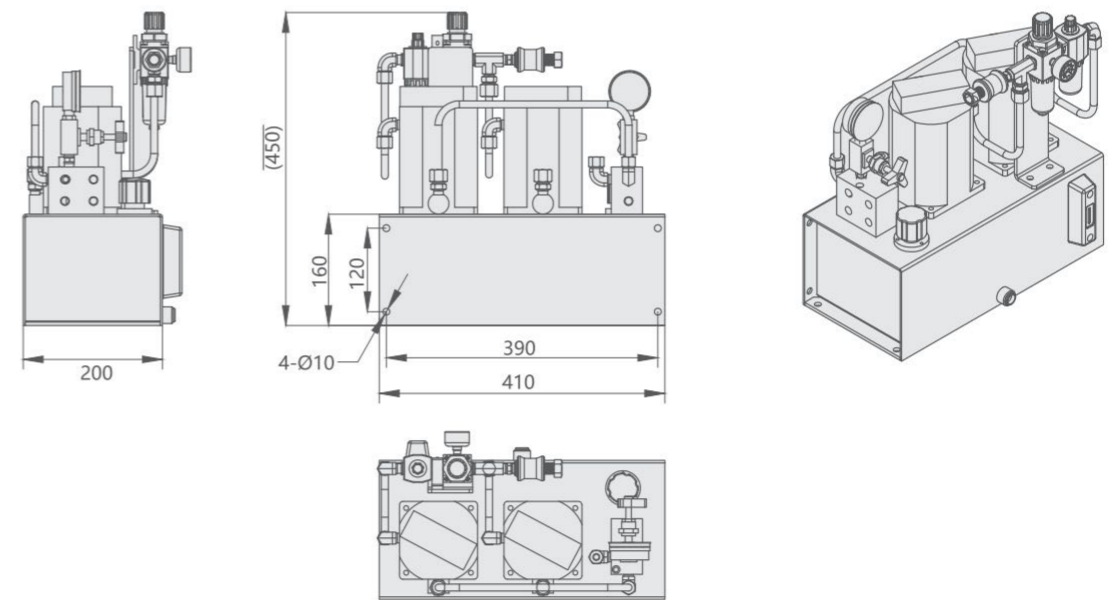

#### 规格参数表 SPECIFICATION

增压倍数	油压吐出量	油箱容积	使用液压油
BOOSTER PRESSURE RATE	HYDRAULIC FLUID EXPELLED (l/min)	OIL TANK CAPACITY	OIL
05	12	单泵 single pump 5L 双泵 Double pump 7.8L	ISO-VG32#
10	5		
16	3		
25	2.5		
44	1.4		

# CLAMPING SCREW

## 螺杆

### PTA/PTB/PTC/PTD

#### PTA动向钢珠螺杆

材质: 本体S45C 钢珠SUJ2  
 硬度: 本体HRC35° 钢珠HRC62°

#### PTA SWIVEL CLAMPING SCREW

Material: Body : S45C Steel ball : SUJ2  
 Hardness: Body: HR35° Steel ball: HRC62°

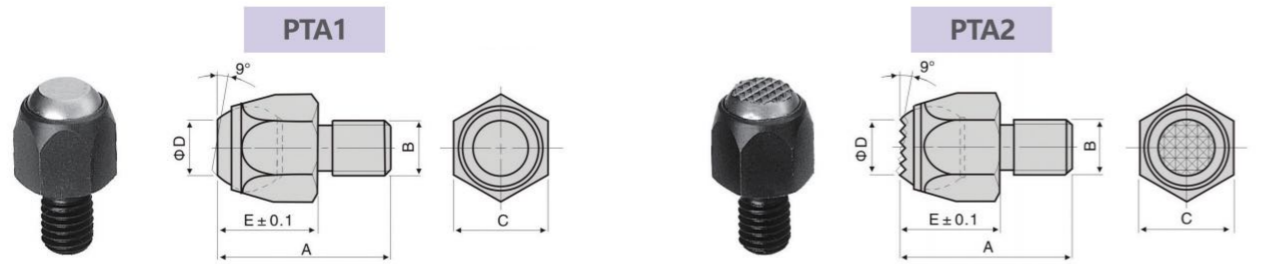

Unit:mm

MODEL	PTA1-0006 PTA2-0006	PTA1-0108 PTA2-0108	PTA1-0210 PTA2-0210	PTA1-0312 PTA2-0312	PTA1-0416 PTA2-0416	PTA1-0520 PTA2-0520	PTA1-0624 PTA2-0624	PTA1-0730 PTA2-0730
A	21	25	30	35	42	55	65	80
B	M6x1.0	M8x1.25	M10x1.5	M12x1.75	M16x2.0	M20x2.5	M24x2.0	M30x2.0
C	10	14	17	22	27	36	36	46
D	6	8	10	12	14	14	18	21
E	10	12	16	22	26	27	32	35
单重(g)	12	15	25	70	140	280	560	880



Unit:mm

MODEL	PTA3-0108 PTA4-0108	PTA3-0210 PTA4-0210	PTA3-0312 PTA4-0312	PTA3-0416 PTA4-0416	PTA3-0520 PTA4-0520	PTA3-0624 PTA4-0624	PTA3-0730 PTA4-0730
A	36	45	50	60	87	98	110
B	M8x1.25	M10x1.5	M12x1.75	M16x2.0	M20x2.5	M24x2.0	M30x2.0
C	14	17	17	24	36	36	46
D	7	8	10	12	14	18	21
E	25	30	35	40	60	66	75
单重(g)	25	55	55	140	330	595	1030

#### PTB动向钢珠螺杆

材质: 本体SCM21 钢珠SUJ2  
 硬度: 本体HRC32°~38° 钢珠HRC62°

#### PTB SWIVEL (SHOULDER) CLAMPING SCREW

Material: Body : SCM21 steel ball : SUJ2  
 Hardness: Body: HRC32°~38° steel ball: HRC62°

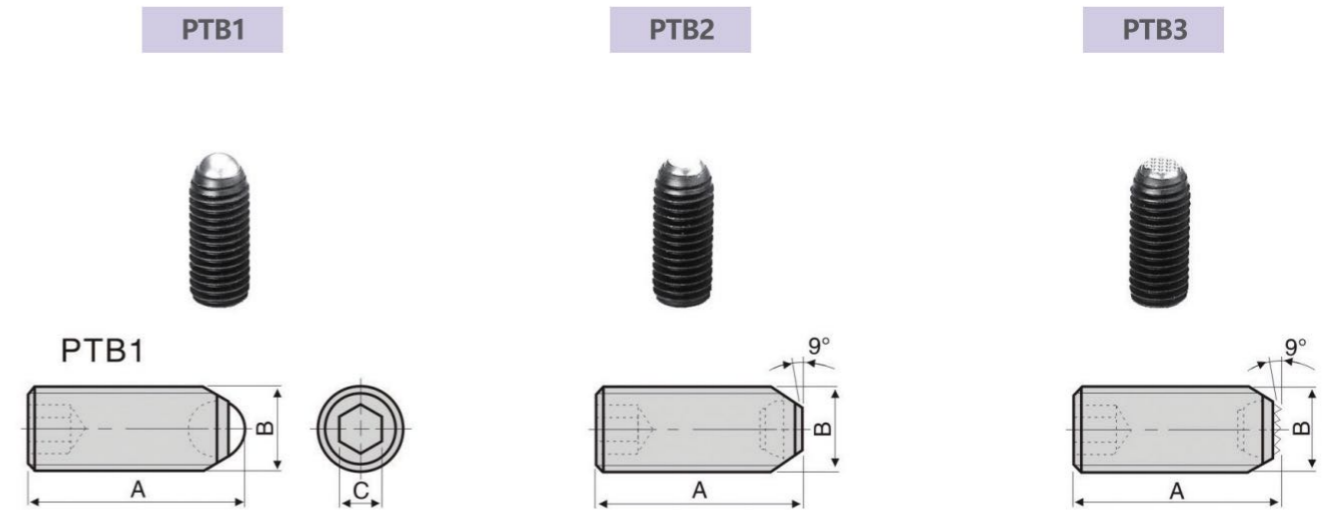

Unit:mm

MODEL	PTB1-0206	PTB1-0306	PTB1-0408	PTB1-0508	PTB1-0608	PTB1-0710	PTB1-0810	PTB1-0910	PTB1-1012	PTB1-1112	PTB1-1212	PTB1-1312
A	13.5	23.5	12	20	30	17	27	37	23.2	31.2	41.2	51.2
B	M6x1.0	M6x1.0	M8x1.25	M8x1.25	M8x1.25	M10x1.5	M10x1.5	M10x1.5	M12x1.75	M12x1.75	M12x1.75	M12x1.75
C	3	3	4	4	4	5	5	5	6	6	6	6
单重(g)	2.4	3.8	3.2	5.8	9	6.7	11.2	16.2	12.5	20	30	40

Unit:mm

MODEL	PTB1-1416	PTB1-1516	PTB1-1616	PTB1-1716	PTB1-1816	PTB2-2006 PTB3-3806	PTB2-2106 PTB3-3906	PTB2-2208 PTB3-4008	PTB2-2308 PTB3-4108	PTB2-2408 PTB3-4208	PTB2-2510 PTB3-4310	PTB2-2610 PTB3-4410
A	25.6	35.6	45.6	55.6	65.6	13	23	11.2	19.2	29.2	15	25
B	M16x2.0	M16x2.0	M16x2.0	M16x2.0	M16x2.0	M6x1.0	M6x1.0	M8x1.25	M8x1.25	M8x1.25	M10x1.5	M10x1.5
C	8	8	8	8	8	3	3	4	4	4	5	5
单重(g)	28	40	45	55	65	2.4	3.8	3.2	5.8	9	6.7	11.2

Unit:mm

MODEL	PTB2-2710 PTB3-4510	PTB2-2812 PTB3-4612	PTB2-2912 PTB3-4712	PTB2-3012 PTB3-4812	PTB2-3112 PTB3-4912	PTB2-3216 PTB3-5016	PTB2-3316 PTB3-5116	PTB2-3416 PTB3-5216	PTB2-3516 PTB3-5316	PTB2-3616 PTB3-5416
A	35	22	30	40	50	24	34	44	54	64
B	M10x1.5	M12x1.75	M12x1.75	M12x1.75	M12x1.75	M16x2.0	M16x2.0	M16x2.0	M16x2.0	M16x2.0
C	5	6	6	6	6	8	8	8	8	8
单重(g)	16.2	12.5	20	30	40	28	40	45	55	65

## PTB动向钢珠螺杆

材质: 本体SCM21 钢珠SUJ2  
 硬度: 本体HRC32°~38° 钢珠HRC62°

## PTB SWIVEL (SHOULDER) CLAMPING SCREW

Material: Body : SCM21 steel ball : SUJ2  
 Hardness: Body: HRC32°~38° steel ball: HRC62°

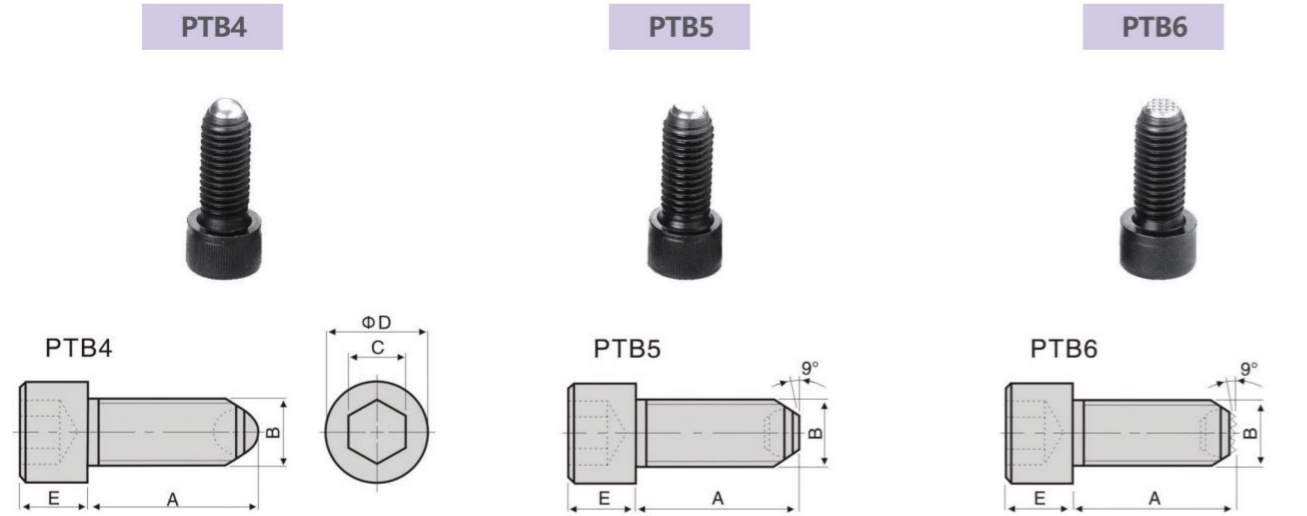

Unit:mm

MODEL	PTB4-0106	PTB4-0206	PTB4-0306	PTB4-0408	PTB4-0508	PTB4-0608	PTB4-0710	PTB4-0810	PTB4-0910	PTB4-1012	PTB4-1112	PTB4-1212	PTB4-1312	PTB4-1416
A	14.5	23.5	33.5	18.7	28.7	38.7	25	40	60	31.2	46.2	66.2	81.2	40.6
B	M6	M6	M6	M8	M8	M8	M10	M10	M10	M12	M12	M12	M12	M16
C	5	5	5	6	6	6	8	8	8	10	10	10	10	14
D	10	10	10	13	13	13	16	16	16	18	18	18	18	24
E	6	6	6	8	8	8	10	10	10	12	12	12	12	16
单重(g)	5.3	7.4	9.5	13.5	20	24	26	34	46	40	50	70	83	90

Unit:mm

MODEL	PTB4-1516	PTB4-1616	PTB4-1716	PTB5-1806 PTB6-3506	PTB5-1906 PTB6-3606	PTB5-2006 PTB6-3706	PTB5-2108 PTB6-3808	PTB5-2208 PTB6-3908	PTB5-2308 PTB6-4008	PTB5-2410 PTB6-4110	PTB5-2510 PTB6-4210	PTB5-2610 PTB6-4310
A	50.6	65.6	90.6	14	23	33	18	28	38	24	39	59
B	M16	M16	M16	M6	M6	M6	M8	M8	M8	M10	M10	M10
C	14	14	14	5	5	5	6	6	6	8	8	8
D	24	24	24	10	10	10	13	13	13	16	16	16
E	16	16	16	6	6	6	8	8	8	10	10	10
单重(g)	110	130	170	5.3	7.4	9.5	13.5	20	24	26	34	46

Unit:mm

MODEL	PTB5-2712 PTB6-4412	PTB5-2812 PTB6-4512	PTB5-2912 PTB6-4612	PTB5-3012 PTB6-4712	PTB5-3116 PTB6-4816	PTB5-3216 PTB6-4916	PTB5-3316 PTB6-5016	PTB5-3416 PTB6-5116
A	30	45	65	80	39	49	64	89
B	M12	M12	M12	M12	M16	M16	M16	M16
C	10	10	10	10	14	14	14	14
D	18	18	18	18	24	24	24	24
E	12	12	12	12	16	16	16	16
单重(g)	40	50	70	83	90	110	13	170

## PTC齿型螺杆

材质: 本体S45C 齿形SKH9  
 硬度: 本体HRC35° 齿形HRC60°

## PTC GRIPPER SCREW

Material: body : S45C steel ball : SKH9  
 Hardness: body: HRC35° steel ball : HRC60°

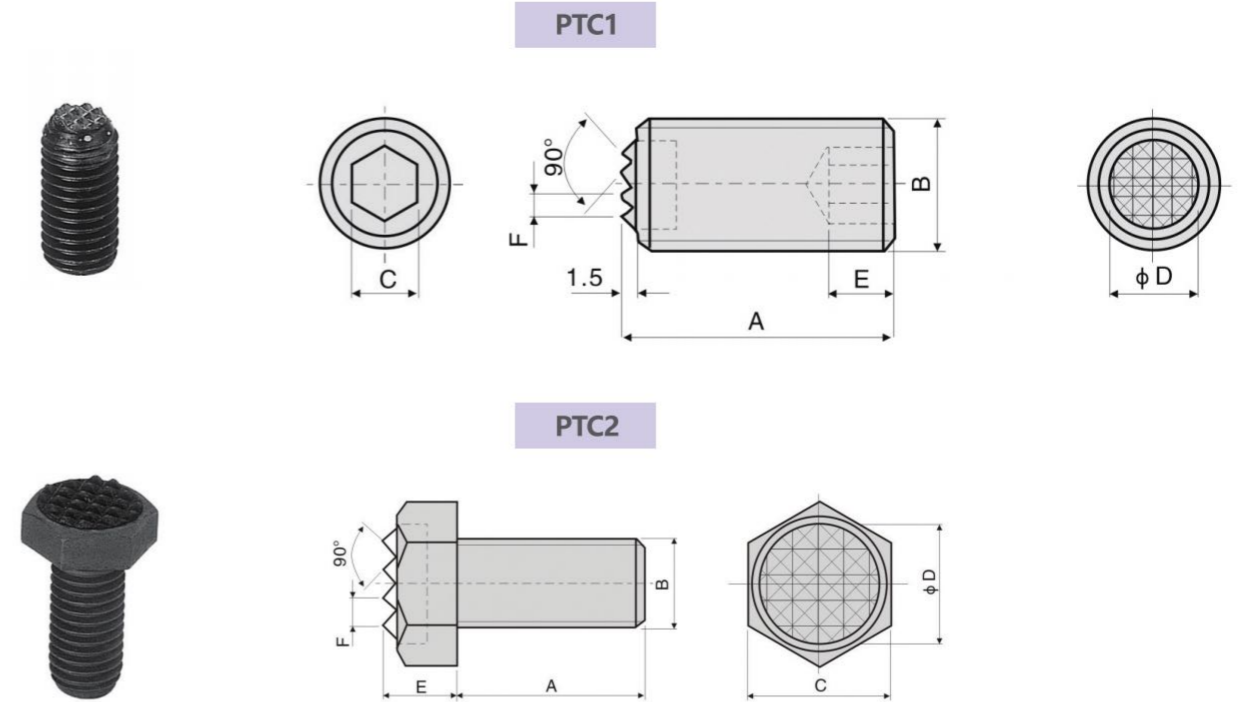

Unit:mm

MODEL	PTC1-0110	PTC1-0210	PTC1-0312	PTC1-0412	PTC1-0516	PTC1-0616	PTC1-0720	PTC1-0820
A	25	50	25	50	25	50	25	50
B	M10x1.5	M10x1.5	M12x1.75	M12x1.75	M16x2.0	M16x2.0	M20x2.5	M20x2.5
C	5	5	6	6	8	8	10	10
D	6.5	6.5	8	8	11.5	11.5	13	13
E	4	5	5	5	6	6	8	8
F	2.3	2.3	2.3	2.3	3	3	3	3
单重(g)	15	30	22	45	37	78	58	120

Unit:mm

MODEL	PTC2-0106	PTC2-0208	PTC2-0310	PTC2-0410	PTC2-0512	PTC2-0612	PTC2-0716	PTC2-0816	PTC2-0920	PTC2-1020
A	25	25	25	40	25	40	35	50	40	60
B	M6x1.0	M8x1.25	M10x1.5	M10x1.5	M12x1.75	M12x1.75	M16x2.0	M16x2.0	M20x2.5	M20x2.5
C	10	13	17	17	19	19	24	24	30	30
D	7.9	9.5	12.7	12.7	15.9	15.9	19.1	19.1	25.4	25.4
E	6	7.3	8.4	8.4	9.5	9.5	12	12	14.5	14.5
F	2.3	3	3	3	3	3	3	3	3	3
单重(g)	8	15	30	35	35	50	85	100	160	205

## PTD支持件

PTD1/PTD2/PTD3 材质:SKH9 硬度HRC60°  
PTD4/PTD5 材质:SCM440 硬度HRC60°

## PTD GRIPPER NUT

Material for PTD1/PTD2/PTD3: body : SKH9 Hardness: HRC60°  
Material for PTD4/PTD5: body : SCM440 Hardness: HRC60°

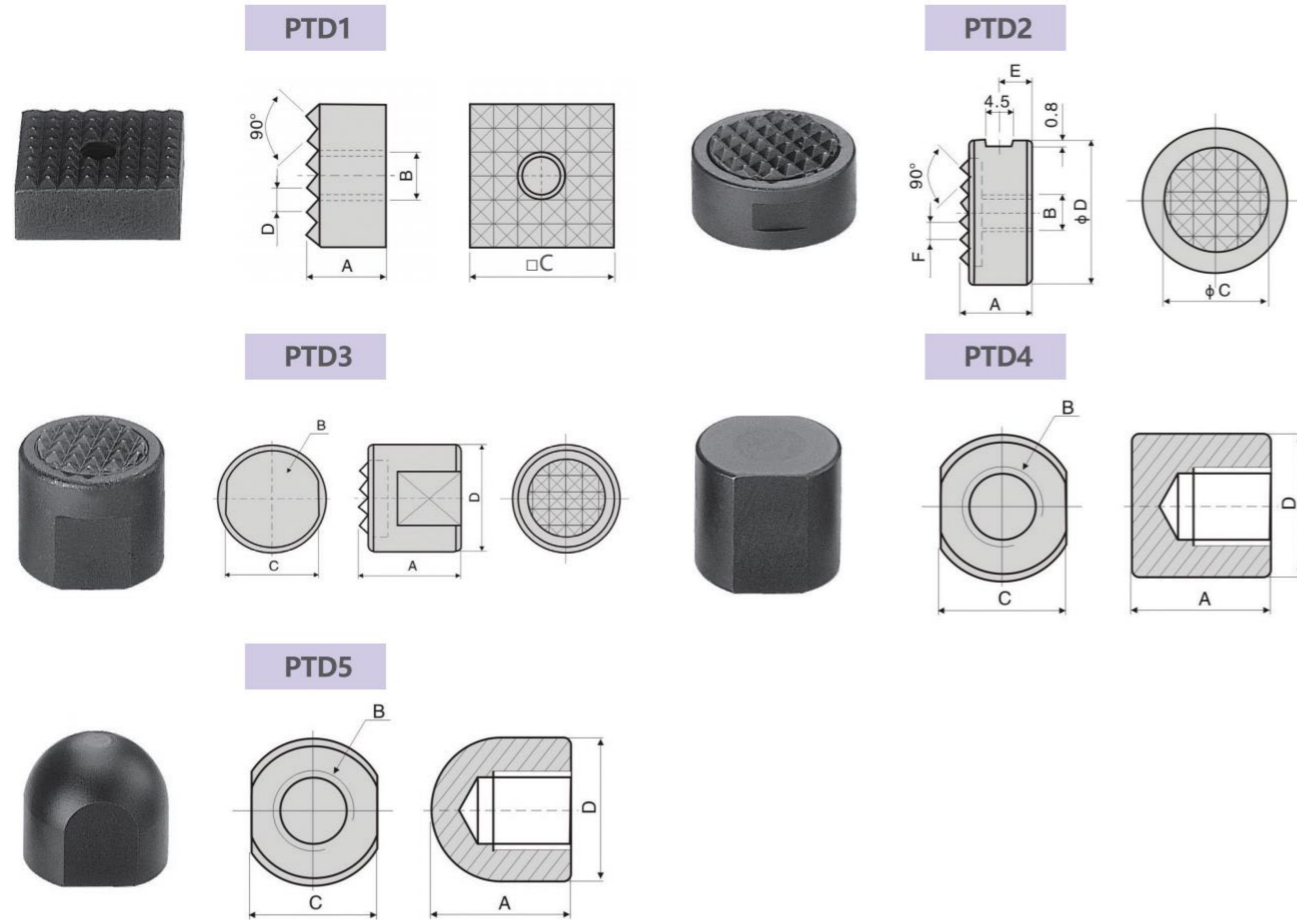

Unit:mm

MODEL	PTD1-0110	PTD1-0212	PTD1-0320	PTD1-0425	PTD3-0112	PTD3-0216	PTD4-0112	PTD4-0216	PTD5-0112	PTD5-0216
A	10	10	10	10	20	25	20	25	20	25
B	M5x0.8	M6x1.0	M6x1.0	M6x1.0	M12x1.75	M16x2.0	M12x1.75	M16x2.0	M12x1.75	M16x2.0
C	10	12	20	25	19	24	19	24	19	24
D	2.3	3	3	3	22	28	22	28	22	28
单重(g)	8	10	30	43	43	80	43	76	42	63

Unit:mm

MODEL	PTD2-0110	PTD2-0212	PTD2-0316	PTD2-0420	PTD2-0525
A	10	12	12	12	12
B	M5x0.8	M6x1.0	M6x1.0	M6x1.0	M6x1.0
C	8.1	9.6	13	16.3	19.5
D	10	12	16	20	25
E	3.4	4	4	4	4
F	2.3	3	3	3	3
单重(g)	5	8	16	25	40

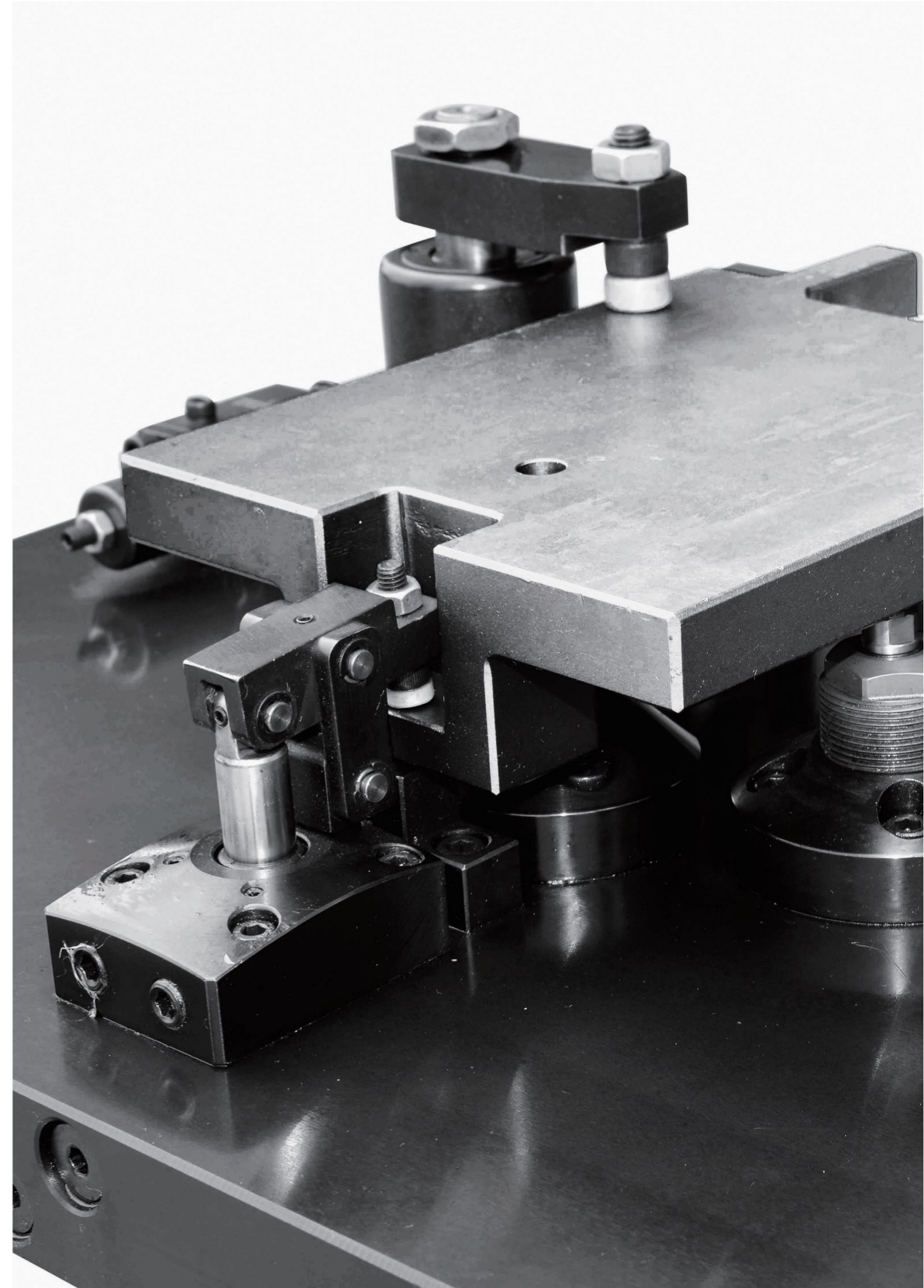

# BLOCK-CLAMP

## 压板

CP25/CP28/CP27

### CP25压板

CP25 STEP CLAMP

材质Material: Steel 45

热处理Heat Treatment: HRC 32°~38°

表面发黑处理Surface: Black oxidating

用途:与SU25配合使用Application: Used with SU25 together

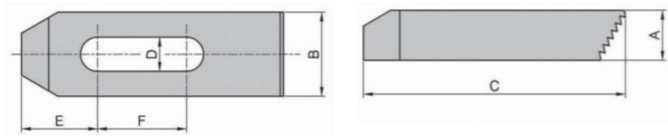

Unit:mm

MODEL	A	B	C	D	E	F	kg
CP25-10063	13	25	63	11	18	19	0.100
CP25-10100	16	25	100	11	27	37	0.215
CP25-10150	19	32	150	11	30	50	0.570
CP25-12063	13	25	63	13	20	14	0.100
CP25-12100	19	32	100	13	29	34	0.320
CP25-12150	22	32	150	13	32	50	0.650
CP25-14063	13	25	63	15	20	14	0.100
CP25-14100	19	32	100	15	29	34	0.315
CP25-14150	22	32	150	15	32	50	0.600
CP25-16063	16	32	63	17	22	12	0.160
CP25-16100	19	38	100	17	31	26	0.400
CP25-16150	22	38	150	17	40	47	0.710
CP25-18063	16	32	63	20	22	12	0.140
CP25-18100	19	38	100	20	31	26	0.380
CP25-18150	22	38	150	20	40	47	0.750
CP25-20100	19	38	100	21	31	26	0.360
CP25-20150	25	38	150	21	43	44	0.750
CP25-20200	25	50	200	21	55	65	1.500
CP25-24150	32	50	150	26	43	38	1.290
CP25-24200	32	50	200	26	53	57	2.000
CP25-24250	38	50	250	26	60	64	2.950

### CP28鸟型压板组

CP28 GOOSE NECK CLAMP

材质Material: Steel 45

热处理Heat Treatment: HRC 32°~38°

表面发黑处理Surface: Black oxidating.

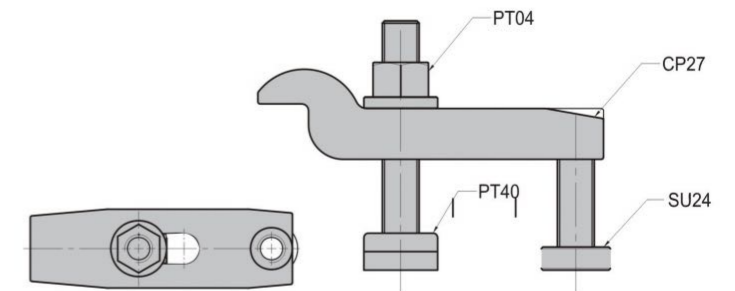

Unit:mm

MODEL	CP27	PT40	PT04	SU24	kg
CP28-ZC-40	16100	16100	1624	12060	1.5
CP28-ZC-60	16150	16100	1624	16070	2.6

### CP27鸟型压板

CP27 THREADED GOOSE NECK CLAMP

材质Material: Steel 45

热处理Heat Treatment: HRC 32°~38°

表面发黑处理Surface: Black oxidating.

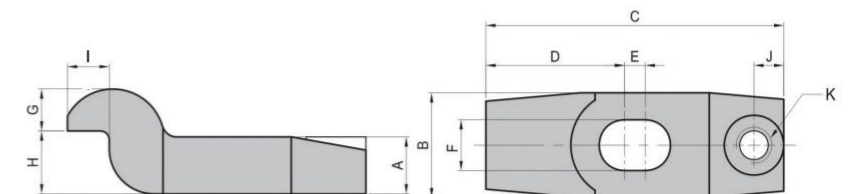

Unit:mm

MODEL	A	B	C	D	E	F	G	H	I	J	K	kg
CP27-16100	19	35	100	46.5	7	17	14	21	14	10	M12×1.75	0.78
CP27-16150	22	45	150	62	26	17	15	24	22	12	M6×2.0	1.7

# CLAMPING ARM ACCESSORIES

## 压臂配件尺寸

### 030/050 系列

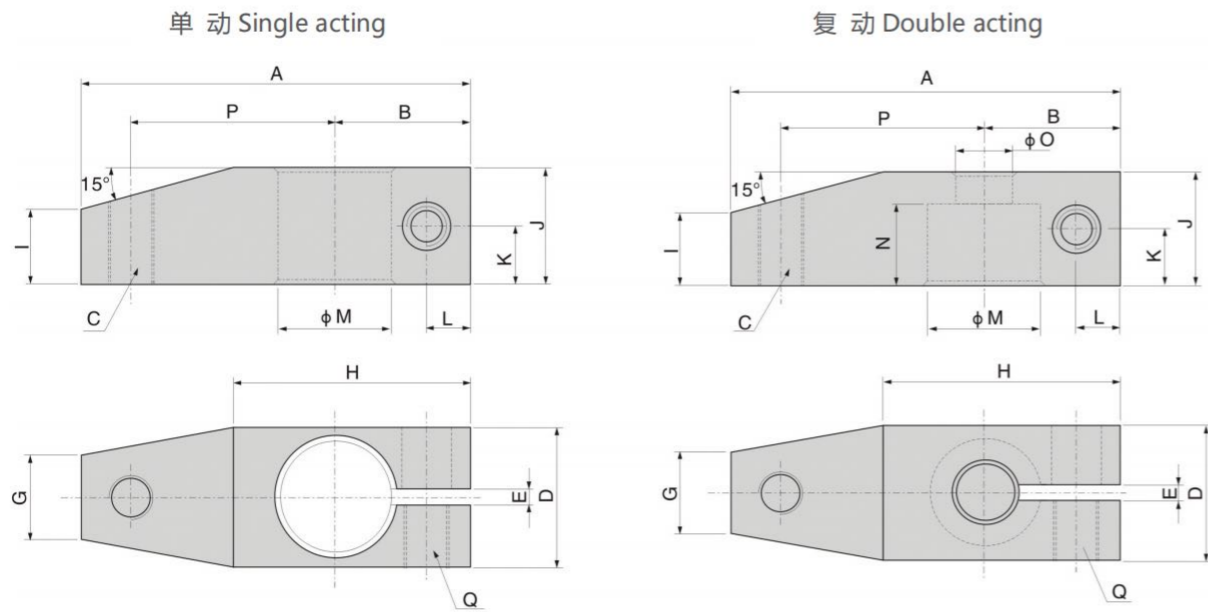

Unit:mm

Type	A	B	C		D	E	G	H	I	J	K	L	M	N	O	P	Q	
			英制 (Imperial system)	公制 (Metric system)														
030/050 单动Single acting	LS/RS-92	86	30	-	M10x1.5	38	3.5	18	45	16	25	10.5	9.75	φ25	-	-	45	M10x1.5
030/050 单动Single acting	LS/RS-202	106	36	1/2-13UNC	M12x1.75	48	3.5	25	60	21	32	14	11	φ32	-	-	55	M12x1.75
030/050 复动Double acting	LD/RD-92	86	30	-	M10x1.5	38	3.5	18	45	16	25	10.5	9.75	φ25	18	φ12.5	45	M10x1.5
030/050 复动Double acting	LD/RD-202	106	36	1/2-13UNC	M12x1.75	48	3.5	25	60	21	32	14	11	φ32	-	-	55	M12x1.75

### CHS 系列

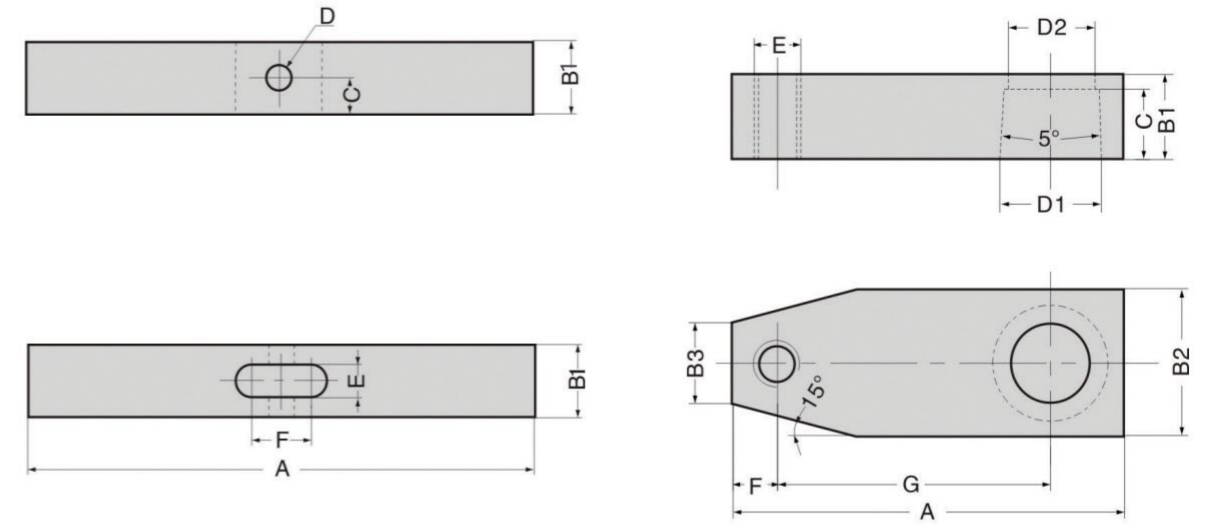

Unit:mm

型号	标准型攻牙	标准型无牙	加长型无牙										
MODEL	A STANDARD WITH THREAD	A STANDARD WITHOUT THREAD	A EXTENSION	B1	B2	B3	C	D	D1	D2	E	F	G
CHS-25	74	74	100	16	27	15	13	-	φ18	φ15	M10x1.5	10	50
CHS-32	81	81	110	18	31	17	14	-	φ20	φ17	M10x1.5	10	55
CHS-40	86	86	120	18	31	17	15	-	φ22.4	φ19	M10x1.5	10	60
CHS-50	96	96	130	20	37	19	16	-	φ28	φ21	M12x1.75	12	65
CHS-63	114	114	150	23	48	24	18	-	φ35.5	φ25	M16x2.0	15	75
CHS-25D	-	140	200	□19	-	-	9.5	φ8	-	-	9	16	-
CHS-32D	-	160	230	□22	-	-	11	φ8	-	-	10	19	-
CHS-40D	-	160	230	□22	-	-	11	φ10	-	-	10	21	-
CHS-50D	-	180	260	□25	-	-	12.5	φ12	-	-	12	26	-
CHS-63D	-	200	-	□32	-	-	16	φ15	-	-	15	33	-

# PRODUCT WEIGHT

## 产品重量表

### CHTB薄型油压缸 CHTB HYDRAULIC PUSH-PULL CYLINDER

Unit:kg

BORE/STROKE			5	10	15	20	25	30	40	50
Φ20	SD	N	-	0.63	-	0.74	-	0.85	-	-
Φ20	SD	W	-	0.68	-	0.79	-	0.9	-	-
Φ25	SD	N	-	0.87	-	1.01	-	1.15	1.29	1.43
Φ25	SD	W	-	0.92	-	1.06	-	1.2	1.34	1.48
Φ32	SD	N	1.61	1.73	1.85	1.97	2.09	2.21	2.45	2.69
Φ32	SD	W	1.71	1.83	1.95	2.07	2.19	2.31	2.55	2.79
Φ32	LA	N	-	1.71	-	1.97	-	2.23	2.49	2.75
Φ32	LA	W	-	1.81	-	2.07	-	2.33	2.59	2.85
Φ40	SD	N	2.0	2.15	2.3	2.45	2.6	2.75	3.05	3.35
Φ40	SD	W	2.2	2.35	2.5	2.65	2.8	2.95	3.25	3.55
Φ40	LA	N	-	2.19	-	2.53	-	2.87	3.21	3.55
Φ40	LA	W	-	2.39	-	2.73	-	3.07	3.41	3.75
Φ50	SD	N	2.78	2.96	3.14	3.32	3.5	3.68	4.04	4.4
Φ50	SD	W	3.03	3.21	3.39	3.57	3.75	3.93	4.29	4.65
Φ50	LA	N	-	3.24	-	3.68	-	4.12	4.56	5
Φ50	LA	W	-	3.49	-	3.93	-	4.37	4.81	5.25
Φ63	SD	N	4.24	4.48	4.72	4.96	5.2	5.44	5.92	6.4
Φ63	SD	W	4.69	4.93	5.17	5.41	5.65	5.89	6.37	6.85
Φ63	LA	N	-	5.22	-	5.84	-	6.46	7.08	7.7
Φ63	LA	W	-	5.67	-	6.29	-	6.91	7.53	8.15
Φ80	SD	N	7.46	7.8	8.14	8.48	8.82	9.16	9.84	10.52
Φ80	SD	W	8.31	8.65	8.99	9.33	9.67	10.01	10.69	11.37

注：本表记载为单轴心标准品 Remark: This form is standard product with single shaft

① CTC ② CSV/CPRV/CFCV ③ HB ④ CALC ⑤ HPS Unit:kg

型号	重量	型号	重量	型号	重量	型号	重量	型号	重量	型号	重量	型号	重量
MODEL	WEIGHT(kg)	MODEL	WEIGHT(kg)	MODEL	WEIGHT(kg)	MODEL	WEIGHT(kg)	MODEL	WEIGHT(kg)	MODEL	WEIGHT(kg)	MODEL	WEIGHT(kg)
CTC-12A	0.07	CSV	0.59	HB-9x6	3.7	CALC-25	0.27	CALC-MS25	0.29	HPS-25	1.15		1.35
CTC-12B	0.08	CLSV	0.35	HB-3.8x45	8.8	CALC-32	0.42	CALC-MS32	0.48	HPS-40	2.57		3.02
CTC-16A	0.14	CPRV-02	1.2	HB-5x35	8.8	CALC-40	0.55	CALC-MS40	0.63	HPS-50	-		4.6
CTC-16B	0.15	CFCV-01	0.08	HB-8x22	8.8	CALC-50	0.95	CALC-MS50	1.05	HPS-63	-		5.8
CTC-20A	0.22	CFCV-02	0.15	-	-	CALC-63	1.45	CALC-MS63	1.6	-	-		-
CTC-20B	0.24	-	-	-	-	-	-	-	-	-	-		-
CTC-25A	0.37	-	-	-	-	-	-	-	-	-	-		-
CTC-25B	0.4	-	-	-	-	-	-	-	-	-	-		-

① CTC外螺纹单动油压缸 CTC Threaded cylinder ② CSV/CPRV/CFCV油压阀 CSV/CPRV/CFCV Hydraulic valve ③ HB增压器 HB Hydraulic booster ④ CALC杠杆式气压缸 CALC Pneumatic leverage camp ⑤ HPS高压转角缸 HPS High pressure swing camp

### CHS/HSC油压转角缸 CHS/HSC HYDRAULIC SWING CLAMP

Unit:kg

型号	配管式	MF 深孔型附调速		M油路板型	FA法兰型	FAM法兰型油路板	TB 全牙型
MODEL	LINE TYPE	MANIFOLD WITH FLOW CONTROL		MANIFOLD TYPE	FLANGE TYPE	FLANGE WITH MANIFOLD	THREADED TYPE
		标准行程 Standard stroke	加长行程 Extension stroke				
HSC/CHS-25S	1.3	-	1.3	-	1.8	1.3	1.3
HSC/CHS-25D	1.5	-	1.5	-	2	1.5	1.5
HSC/CHS-32S	1.7	1.9	1.7	1.9	2.2	1.7	1.7
HSC/CHS-32D	2.0	2.2	2.0	2.2	2.5	2.0	2.0
HSC/CHS-40S	2.3	2.2	2.0	2.2	3.3	2.3	2.4
HSC/CHS-40D	3.2	2.5	2.3	2.5	3.6	2.6	2.7
HSC/CHS-50S	3.5	3.5	3.2	3.5	4.3	3.4	3.5
HSC/CHS-50D	5.1	3.5	3.5	3.8	4.6	3.7	3.8
HSC/CHS-63S	5.7	5.5	5.0	5.4	-	5.2	-
HSC/CHS-63D	-	6.1	5.6	6.0	-	5.6	-

### ASC气压转角缸 ASC PNEUMATIC SWING CLAMP

Unit:kg

型号	配管式	MF 深孔型附调速	MS感应型	FA法兰型	TB 全牙型	
MODEL	LINE TYPE	MANIFOLD WITH FLOW CONTROL		MAGNETIC TYPE	FLANGE TYPE	THREADED TYPE
		标准行程 Standard stroke	加长行程 Extension stroke			
ASC-25S	0.3	-	-	0.4	-	-
ASC-32S	0.7	0.8	0.6	0.7	0.6	0.9
ASC-32D	0.9	1.0	0.8	0.9	0.8	1.1
ASC-40S	0.9	1.0	0.8	0.9	0.8	1.1
ASC-40D	1.1	1.2	1.0	1.1	1.0	1.3
ASC-50S	1.6	1.7	1.4	1.6	1.4	1.7
ASC-50D	1.8	1.9	1.6	1.8	1.6	1.9
ASC-63S	2.1	2.2	1.8	2.3	1.8	-
ASC-63D	2.3	2.4	2.0	2.5	2.0	-

### CHLC杠杆式油压缸 CHLC HYDRAULIC LEVERAGE CLAMP

Unit:kg

型号	配管式	MF油路板附调速	M油路板型	FA法兰型	FAM法兰型油路板
MODEL	LINE TYPE	MANIFOLD WITH FLOW CONTROL		FLANGE TYPE	FLANGE WITH MANIFOLD
		MANIFOLD WITH FLOW CONTROL	MANIFOLD TYPE		
CHLC-25	1.9	2.1	1.9	1.4	1.4
CHLC-32	2.1	2.2	2.1	1.7	1.7
CHLC-40	3.3	3.6	3.3	2.5	2.3
CHLC-50	4.4	4.8	4.5	3.8	3.6
CHLC-63	8.3	-	8.4	-	-

## CLAMPTEK BRAND

嘉刚研发产品



## CLAMPTEK AGENCY

嘉刚4大代理产品



## CLAMPTEK LEADING THE GLOBAL CLAMPING TECHNOLOGY

嘉刚引领全球夹具技术

